



**THE DATASHEET OF
XC17S10XLPDG8C**





Spartan/XL Family One-Time Programmable Configuration PROMs (XC17S00/XL)

DS030 (v1.12) June 20, 2008

Product Specification

Features

- Configuration one-time programmable (OTP) read-only memory designed to store configuration bitstreams for Spartan®, and Spartan-XL FPGAs
- Simple interface to the Spartan device requires only one user I/O pin
- Programmable reset polarity (active High or active Low)
- Low-power CMOS floating-gate process
- Available in 5V and 3.3V versions
- Available in compact plastic 8-pin DIP, 8-pin VOIC, or 20-pin SOIC packages
- Programming support by leading programmer manufacturers
- Lead-free (RoHS-compliant) packaging available
- Design support using the Xilinx® Alliance and Foundation™ series software packages
- Guaranteed 20 year life data retention

Introduction

The Spartan family of PROMs provides an easy-to-use, cost-effective method for storing Spartan device configuration bitstreams.

When the Spartan device is in Master Serial mode, it generates a configuration clock that drives the Spartan FPGA PROM. A short access time after the rising clock edge, data appears on the PROM DATA output pin that is connected to the Spartan device D_{IN} pin. The Spartan device generates the appropriate number of clock pulses to

complete the configuration. Once configured, it disables the PROM. When a Spartan device is in Slave Serial mode, the PROM and the Spartan device must both be clocked by an incoming signal.

For device programming, either the Xilinx Alliance or the Foundation series development systems compile the Spartan device design file into a standard HEX format which is then transferred to most commercial PROM programmers.

Spartan FPGA	Configuration Bits	Compatible Spartan PROM
XCS05	53,984	XC17S05
XCS05XL	54,544	XC17S05XL
XCS10	95,008	XC17S10
XCS10XL	95,752	XC17S10XL
XCS20	178,144	XC17S20
XCS20XL	179,160	XC17S20XL
XCS30	247,968	XC17S30
XCS30XL	249,168	XC17S30XL
XCS40	329,312	XC17S40
XCS40XL	330,696	XC17S40XL
XC2S50 ⁽¹⁾	559,200	XC17S50XL
XC2S100 ⁽¹⁾	781,216	XC17S100XL
XC2S150 ⁽¹⁾	1,040,096	XC17S150XL

Notes:

1. For new Spartan-II FPGA designs, it is recommended to use the 17S00A family.

Pin Description

Pins not listed in Table 1 are "no connects."

Table 1: Spartan PROM Pinouts

Pin Name	8-pin PDIP (PD8) and VOIC/TSOP (VO8)	20-pin SOIC (SO20)	Pin Description
DATA	1	1	Data output, High-Z state when either \overline{CE} or \overline{OE} are inactive. During programming, the DATA pin is I/O. Note that \overline{OE} can be programmed to be either active High or active Low.
CLK	2	3	Each rising edge on the CLK input increments the internal address counter, if both \overline{CE} and \overline{OE} are active.
RESET/ \overline{OE} (OE/RESET)	3	8	When High, this input holds the address counter reset and puts the DATA output in a high-impedance state. The polarity of this input pin is programmable as either RESET/ \overline{OE} or OE/RESET. To avoid confusion, this document describes the pin as RESET/ \overline{OE} , although the opposite polarity is possible on all devices. When RESET is active, the address counter is held at zero, and the DATA output is in a high-impedance state. The polarity of this input is programmable. The default is active High RESET, but the preferred option is active Low RESET, because it can be driven by the FPGAs INIT pin. The polarity of this pin is controlled in the programmer interface. This input pin is easily inverted using the Xilinx HW-130 programmer software. Third-party programmers have different methods to invert this pin.
\overline{CE}	4	10	When High, this pin disables the internal address counter, puts the DATA output in a high-impedance state, and forces the device into low- I_{CC} standby mode.
GND	5	11	GND is the ground connection.
V _{CC}	7, 8	18, 20	The V _{CC} pins are to be connected to the positive voltage supply.

Pinout Diagrams

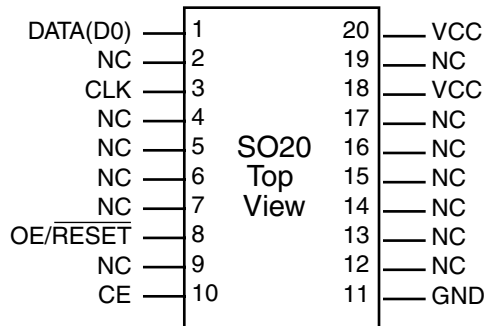

DS030_04_110102

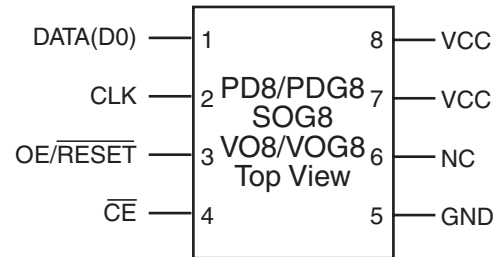

DS030_05_060508

Controlling PROMs

Connecting the Spartan device with the PROM:

- The DATA output of the PROM drives the D_{IN} input of the lead Spartan device.
- The Master Spartan device CCLK output drives the CLK input of the PROM.
- The \overline{RESET}/OE input of the PROM is driven by the \overline{INIT} output of the Spartan device. This connection assures that the PROM address counter is reset before the start of any (re)configuration, even when a reconfiguration is initiated by a V_{CC} glitch. Other methods—such as driving \overline{RESET}/OE from \overline{LDC} or system reset—assume that the PROM internal power-on-reset is always in step with the FPGAs internal power-on-reset, which is not a safe assumption.
- The \overline{CE} input of the PROM is driven by the DONE output of the Spartan device, provided that DONE is not permanently grounded. Otherwise, \overline{LDC} can be used to drive \overline{CE} , but must then be unconditionally High during user operation. \overline{CE} can also be permanently tied Low, but this keeps the DATA output active and causes an unnecessary supply current of 10 mA maximum.

FPGA Master Serial Mode Summary

The I/O and logic functions of the Configurable Logic Block (CLB) and their associated interconnections are established by a configuration program. The program is loaded either automatically upon power up, or on command, depending on the state of the Spartan device MODE pin. In Master Serial mode, the Spartan device automatically loads the configuration program from an external memory. The Spartan FPGA PROM has been designed for compatibility with the Master Serial mode.

Upon power-up or reconfiguration, the Spartan device enters the Master Serial mode when the MODE pin is Low. Data is read from the PROM sequentially on a single data line. Synchronization is provided by the rising edge of the temporary signal CCLK, which is generated during configuration.

Master Serial mode provides a simple configuration interface (Figure 1, page 4). Only a serial data line and two control lines are required to configure the Spartan device. Data from the PROM is read sequentially, accessed via the internal address and bit counters which are incremented on every valid rising edge of CCLK.

If the user-programmable, dual-function D_{IN} pin on the Spartan device is used only for configuration, it must still be held at a defined level during normal operation. The Spartan family takes care of this automatically with an on-chip default pull-up resistor.

Programming the FPGA With Counters Unchanged Upon Completion

When multiple-configurations for a single Spartan device are stored in a PROM, the \overline{OE} pin should be tied Low. Upon power-up, the internal address counters are reset and configuration begins with the first program stored in memory. Since the \overline{OE} pin is held Low, the address counters are left unchanged after configuration is complete. Therefore, to reprogram the FPGA with another program, the DONE line is pulled Low and configuration begins at the last value of the address counters.

This method fails if a user applies \overline{RESET} during the Spartan device configuration process. The Spartan device aborts the configuration and then restarts a new configuration, as intended, but the PROM does not reset its address counter, since it never saw a High level on its \overline{OE} input. The new configuration, therefore, reads the remaining data in the PROM and interprets it as preamble, length count etc. Since the Spartan device is the Master, it issues the necessary number of CCLK pulses, up to 16 million (2^{24}) and DONE goes High. However, the Spartan device configuration will be completely wrong, with potential contentions inside the Spartan device and on its output pins. This method must, therefore, never be used when there is any chance of external reset during configuration.

Standby Mode

The PROM enters a low-power standby mode whenever \overline{CE} is asserted High. The output remains in a high-impedance state regardless of the state of the \overline{OE} input.

Programming the Spartan Family PROMs

The devices can be programmed on programmers supplied by Xilinx or qualified third-party vendors. The user must ensure that the appropriate programming algorithm and the latest version of the programmer software are used. The wrong choice can permanently damage the device.

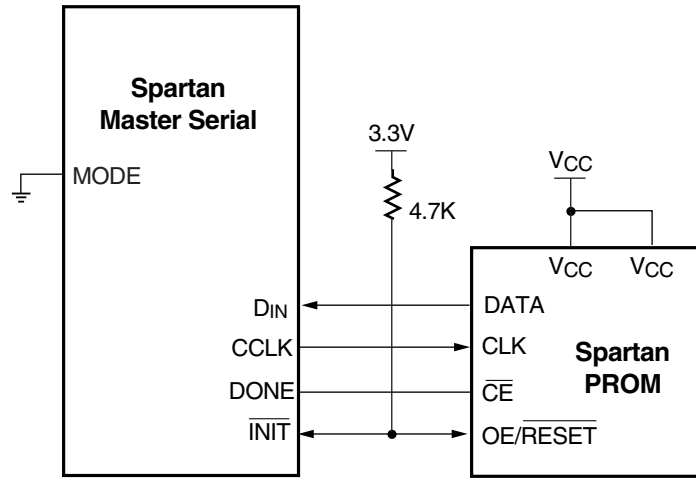

(Low Resets the Address Pointer)

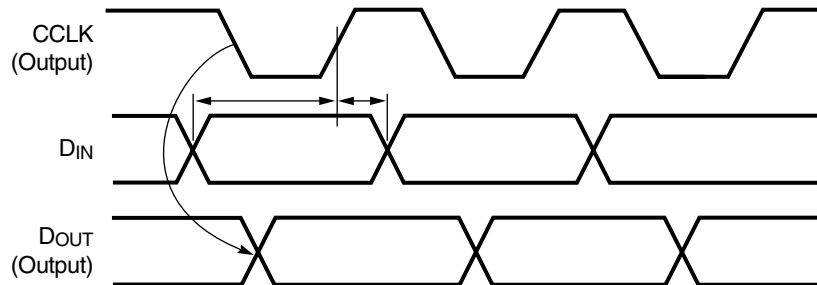

DS030_01_101001

Figure 1: Master Serial Mode

Note: The one-time-programmable Spartan PROM supports automatic loading of configuration programs. An early DONE inhibits the PROM data output one CCLK cycle before the Spartan FPGA I/Os become active.

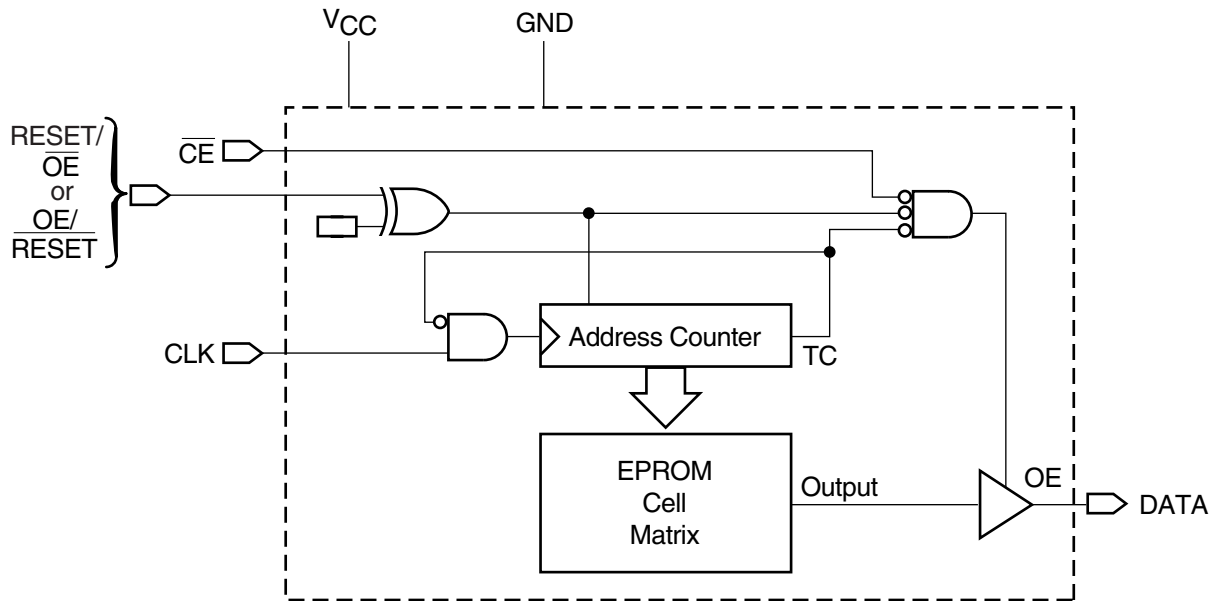

DS030_02_011300

Figure 2: Simplified Block Diagram (Does not Show Programming Circuit)

Caution! Always tie the two V_{CC} pins together in the application.

Table 2: Truth Table for XC17S00 Control Inputs

Control Inputs		Internal Address ⁽²⁾	Outputs	
RESET ⁽¹⁾	CE		DATA	I _{CC}
Inactive	Low	If address ≤ TC: increment If address > TC: don't change	Active High-Z	Active Reduced
Active	Low	Held reset	High-Z	Active
Inactive	High	Not changing	High-Z ⁽³⁾	Standby
Active	High	Held reset	High-Z ⁽³⁾	Standby

Notes:

1. The XC17S00 RESET input has programmable polarity.
2. TC = Terminal Count = highest address value. TC + 1 = address 0.
3. Pull DATA pin to GND or V_{CC} to meet I_{CCS} standby current.

XC17S05, XC17S10, XC17S20, XC17S30, XC17S40

Absolute Maximum Ratings⁽¹⁾

Symbol	Description	Value	Units
V _{CC}	Supply voltage relative to GND	-0.5 to +7.0	V
V _{IN}	Input voltage relative to GND	-0.5 to V _{CC} +0.5	V
V _{TS}	Voltage applied to High-Z output	-0.5 to V _{CC} +0.5	V
T _{STG}	Storage temperature (ambient)	-65 to +150	°C
T _J	Junction temperature	+125	°C

Notes:

- Stresses beyond those listed under Absolute Maximum Ratings can cause permanent damage to the device. These are stress ratings only, and functional operation of the device at these or any other conditions beyond those listed under Operating Conditions is not implied. Exposure to Absolute Maximum Ratings conditions for extended periods of time can affect device reliability.

Operating Conditions⁽¹⁾

Symbol	Description	Conditions	Min	Max	Units
V _{CC}	Commercial	Supply voltage relative to GND (T _A = 0°C to +70°C)	4.75	5.25	V
	Industrial	Supply voltage relative to GND (T _A = -40°C to +85°C)	4.50	5.50	V

Notes:

- During normal read operation both V_{CC} pins must be connected together.

DC Characteristics Over Operating Condition

Symbol	Description	Min	Max	Units	
V _{IH}	High-level input voltage	2.0	V _{CC}	V	
V _{IL}	Low-level input voltage	0	0.8	V	
V _{OH}	High-level output voltage (I _{OH} = -4 mA)	3.86	-	V	
V _{OL}	Low-level output voltage (I _{OL} = +4 mA)				0.32
V _{OH}	High-level output voltage (I _{OH} = -4 mA)	3.76	-	V	
V _{OL}	Low-level output voltage (I _{OL} = +4 mA)				0.37
I _{CCA}	Supply current, active mode (at maximum frequency)	XC17S05, XC17S10, XC17S20, XC17S30	10	mA	
		XC17S40	-	20	mA
I _{CCS}	Supply current, standby mode	XC17S05, XC17S10, XC17S20, XC17S30	-	50 ⁽¹⁾	μA
		XC17S40	-	100 ⁽¹⁾	μA
I _L	Input or output leakage current	-10	10	μA	
C _{IN}	Input Capacitance (V _{IN} = GND, f = 1.0 MHz)	-	10	pF	
C _{OUT}	Output Capacitance (V _{IN} = GND, f = 1.0 MHz)	-	10	pF	

Notes:

- I_{CCS} standby current is specified for DATA pin that is pulled to V_{CC} or GND.

XC17S05XL, XC17S10XL, XC17S20XL, XC17S30XL, XC17S40XL, XC17S50XL, XC17S100XL, XC17S150XL

Absolute Maximum Ratings⁽¹⁾

Symbol	Description	Value	Units
V _{CC}	Supply voltage relative to GND	-0.5 to +4.0	V
V _{IN}	Input voltage with respect to GND	-0.5 to V _{CC} +0.5	V
V _{TS}	Voltage applied to High-Z output	-0.5 to V _{CC} +0.5	V
T _{STG}	Storage temperature (ambient)	-65 to +150	°C

Notes:

- Stresses beyond those listed under Absolute Maximum Ratings can cause permanent damage to the device. These are stress ratings only, and functional operation of the device at these or any other conditions beyond those listed under Operating Conditions is not implied. Exposure to Absolute Maximum Ratings conditions for extended periods of time can affect device reliability.

Operating Conditions⁽¹⁾

Symbol	Description	Min	Max	Units
V _{CC}	Commercial	Supply voltage relative to GND (T _A = 0°C to +70°C)		V
	Industrial	Supply voltage relative to GND (T _A = -40°C to +85°C)		V

Notes:

- During normal read operation both V_{CC} pins must be connected together.

DC Characteristics Over Operating Condition

Symbol	Description	Min	Max	Units
V _{IH}	High-level input voltage	2.0	V _{CC}	V
V _{IL}	Low-level input voltage	0	0.8	V
V _{OH}	High-level output voltage (I _{OH} = -3 mA)	2.4	-	V
V _{OL}	Low-level output voltage (I _{OL} = +3 mA)	-	0.4	V
I _{CCA}	Supply current, active mode (at maximum frequency)	-	5	mA
I _{CCS}	Supply current, standby mode	-	50 ⁽¹⁾	μA
I _L	Input or output leakage current	-10	10	μA
C _{IN}	Input Capacitance (V _{IN} = GND, f = 1.0 MHz)	-	10	pF
C _{OUT}	Output Capacitance (V _{IN} = GND, f = 1.0 MHz)	-	10	pF

Notes:

- I_{CCS} standby current is specified for DATA pin that is pulled to V_{CC} or GND.

AC Characteristics over Operating Condition⁽¹⁾

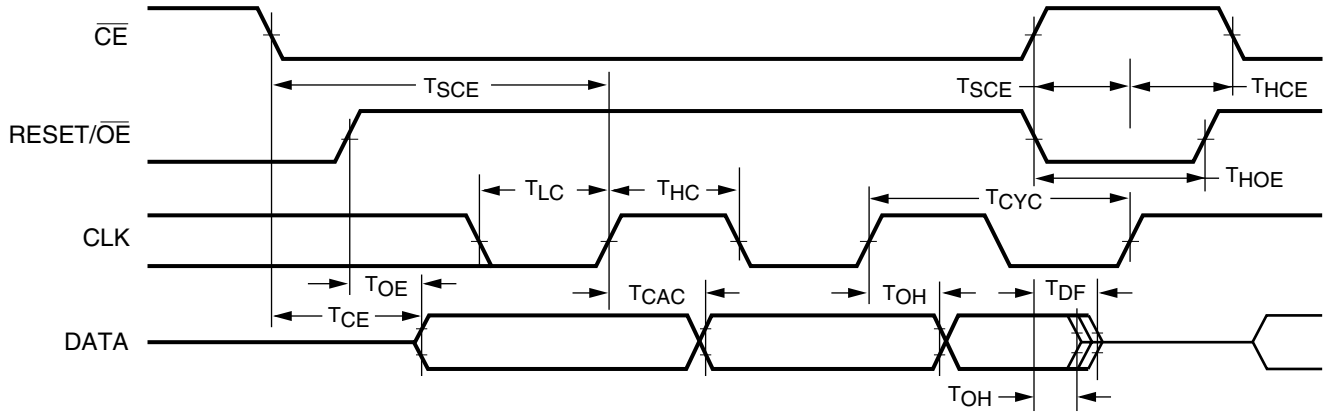

DS0306_03_011300

Symbol	Description	Min	Max	Units
T_{OE}	RESET/ \overline{OE} to Data Delay	-	45	ns
T_{CE}	\overline{CE} to Data Delay	-	60	ns
T_{CAC}	CLK to Data Delay	-	80	ns
T_{OH}	Data Hold From \overline{CE} , RESET/ \overline{OE} , or CLK ⁽²⁾	0	-	ns
T_{DF}	\overline{CE} or RESET/ \overline{OE} to Data Float Delay ^(2,3)	-	50	ns
T_{CYC}	Clock Periods	100	-	ns
T_{LC}	CLK Low Time ⁽²⁾	50	-	ns
T_{HC}	CLK High Time ⁽²⁾	50	-	ns
T_{SCE}	\overline{CE} Setup Time to CLK (to guarantee proper counting)	25	-	ns
T_{HCE}	\overline{CE} Hold Time to CLK (to guarantee proper counting)	0	-	ns
T_{HOE}	RESET/ \overline{OE} Hold Time (guarantees counters are reset)	25	-	ns

Notes:

1. AC test load = 50 pF.
2. Guaranteed by design, not tested.
3. Float delays are measured with 5 pF AC loads. Transition is measured at ± 200 mV from steady state active levels.
4. All AC parameters are measured with $V_{IL} = 0.0V$ and $V_{IH} = 3.0V$.

Ordering Information

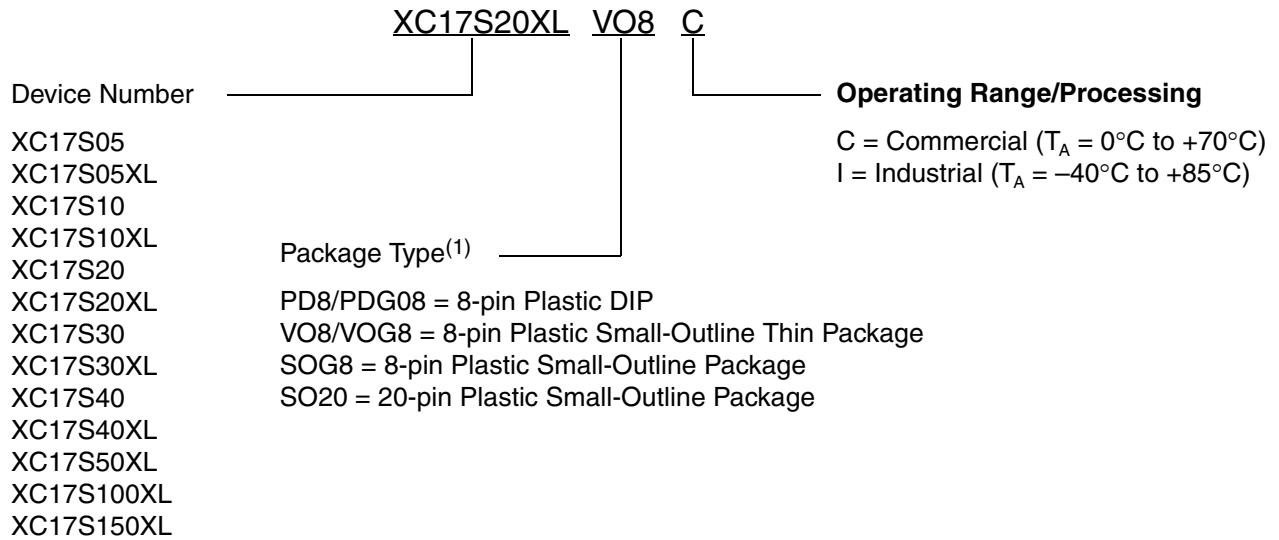

Notes:

1. G in the package-type codes designates Lead-free packaging.

Spartan 5V Valid Ordering Combinations (XC17S00)

XC17S05PD8C	XC17S10PD8C	XC17S20PD8C	XC17S30PD8C	XC17S40PD8C
XC17S05VO8C	XC17S10VO8C	XC17S20VO8C	XC17S30VO8C	XC17S40SO20C
XC17S05PD8I	XC17S10VOG8C	XC17S20PD8I	XC17S30PD8I	XC17S40PD8I
XC17S05VO8I	XC17S10PD8I	XC17S20VO8I	XC17S30VO8I	XC17S40SO20I
	XC17S10VO8I		XC17S30SOG8I	

Spartan 3.3V Valid Ordering Combinations (XC17S00XL)

XC17S05XLPD8C	XC17S100XLPD8C	XC17S20XLPD8C	XC17S40XLPD8C
XC17S05XLVO8C	XC17S100XLSO20C	XC17S20XLVO8C	XC17S40XLPDG8C
XC17S05XLPD8I	XC17S100XLPD8I	XC17S20XLVOG8C	XC17S40XLSO20C
XC17S05XLVO8I	XC17S100XLSO20I	XC17S20XLPD8I	XC17S40XLPD8I
XC17S10XLPD8C	XC17S150XLPD8C	XC17S20XLVO8I	XC17S40XLSO20I
XC17S10XLPDG8C	XC17S150XLSO20C	XC17S30XLPD8C	XC17S50XLPD8C
XC17S10XLVO8C	XC17S150XLPD8I	XC17S30XLPDG8C	XC17S50XLSO20C
XC17S10XLVOG8C	XC17S150XLSO20I	XC17S30XLVO8C	XC17S50XLPD8I
XC17S10XLPD8I		XC17S30XLVOG8C	XC17S50XLSO20I
XC17S10XLVO8I		XC17S30XLPD8I	
XC17S10XLVOG8I		XC17S30XLVO8I	
		XC17S30XLVOG8I	

Marking Information

Due to the small size of the PROM package, the complete ordering part number cannot be marked on the package. The XC prefix is deleted and the package code is simplified. Device marking is as follows.

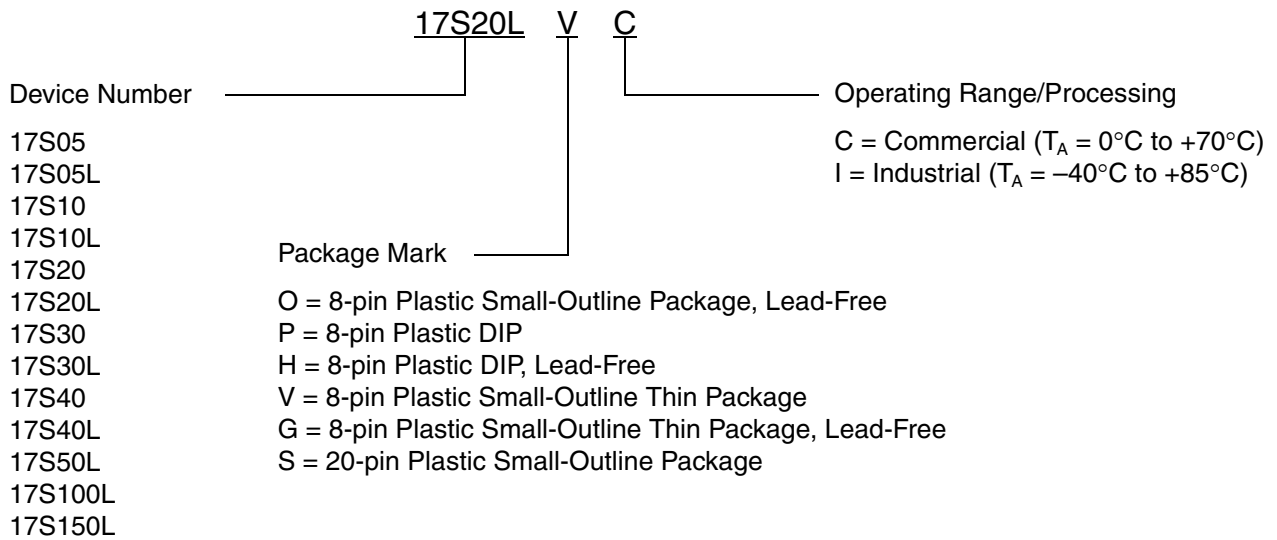

Note: When marking the device number on the XL parts, an L is used in place of an XL.

Revision History

The following table shows the revision history for this document.

Date	Revision	Revision
07/14/98	1.1	Cosmetic edits for pages 1, 2, and 4.
09/08/98	1.2	Clarified the SPARTAN FPGA and PROM interface by removing references to $\overline{\text{CEO}}$ pin. Removed the ESD notation in Absolute Maximum table since it is now included in Xilinx's Reliability Monitor Report.
01/20/00	1.3	Added additional Spartan-XL parts, changed SPROM to PROM.
02/18/00	1.4	Changed device ordering numbers, added 4.7K resistor to OE/ $\overline{\text{RESET}}$ in Figure 1.
04/04/00	1.5	Added XC17S200XL PROM for Spartan XC2S200.
08/06/00	1.6	Updated format.
04/07/01	1.7	Added to features: "Guaranteed 20 year life data retention."
10/10/01	1.8	Added a note to Table 1. Changed V_{PP} to V_{CC} on Figure 1.
11/04/02	1.9	Updated Table 1, page 2. Updated the template. Added "Pinout Diagrams," page 2.
11/18/02	1.10	Modified document title.

07/09/07	1.11	<ul style="list-style-type: none"> • Updated document format. • Left diagram under "Pinout Diagrams," page 2 updated to reflect new Lead-free packaging. • Under "XC17S05, XC17S10, XC17S20, XC17S30, XC17S40," <ul style="list-style-type: none"> ◆ Deleted parameter T_{SOL}, Maximum Soldering Temperature, under "Absolute Maximum Ratings⁽¹⁾," page 6. Refer to UG112, <i>Xilinx Device Package User Guide</i>, for package soldering guidelines. ◆ Added note to "DC Characteristics Over Operating Condition," page 6 and corrected XC17S40 I_{CCA} value. • Under "XC17S05XL, XC17S10XL, XC17S20XL, XC17S30XL, XC17S40XL, XC17S50XL, XC17S100XL, XC17S150XL", added note to "DC Characteristics Over Operating Condition," page 7. • Added Lead-free (RoHS-compliant) packages PDG8 and VOG8 to "Ordering Information," page 9. • Added new part numbers to and deleted XC17S200XL from "Spartan 3.3V Valid Ordering Combinations (XC17S00XL)," page 9. • Added new Lead-free package types G and H to "Marking Information," page 10.
06/20/08	1.12	<ul style="list-style-type: none"> • Updated document template. • Updated copyright statement. • Added "Notice of Disclaimer," page 11. • Added junction temperature to "Absolute Maximum Ratings⁽¹⁾," page 6. • Added support for XC17S30SOG8I. • Added new Lead-free package type O to "Marking Information," page 10. • Updated "Pinout Diagrams," page 2, "Ordering Information," page 9, and "Spartan 5V Valid Ordering Combinations (XC17S00)," page 9.

Notice of Disclaimer

THE XILINX HARDWARE FPGA AND CPLD DEVICES REFERRED TO HEREIN ("PRODUCTS") ARE SUBJECT TO THE TERMS AND CONDITIONS OF THE XILINX LIMITED WARRANTY WHICH CAN BE VIEWED AT <http://www.xilinx.com/warranty.htm>. THIS LIMITED WARRANTY DOES NOT EXTEND TO ANY USE OF PRODUCTS IN AN APPLICATION OR ENVIRONMENT THAT IS NOT WITHIN THE SPECIFICATIONS STATED IN THE XILINX DATA SHEET. ALL SPECIFICATIONS ARE SUBJECT TO CHANGE WITHOUT NOTICE. PRODUCTS ARE NOT DESIGNED OR INTENDED TO BE FAIL-SAFE OR FOR USE IN ANY APPLICATION REQUIRING FAIL-SAFE PERFORMANCE, SUCH AS LIFE-SUPPORT OR SAFETY DEVICES OR SYSTEMS, OR ANY OTHER APPLICATION THAT INVOKES THE POTENTIAL RISKS OF DEATH, PERSONAL INJURY, OR PROPERTY OR ENVIRONMENTAL DAMAGE ("CRITICAL APPLICATIONS"). USE OF PRODUCTS IN CRITICAL APPLICATIONS IS AT THE SOLE RISK OF CUSTOMER, SUBJECT TO APPLICABLE LAWS AND REGULATIONS.

Looking for pricing, stock, or lifecycle information?

Click below to explore more details on WIN SOURCE:

 [View XC17S10XLPDG8C on WIN SOURCE](#)

 [Xilinx Inc. Information](#)

Optimize Your Supply Chain with WIN SOURCE Solutions

-  Global Sourcing Solution
-  Obsolete Management
-  Cost Control Management
-  Shortage Management
-  Alternative Solution
-  Excess Inventory Management