



**THE DATASHEET OF
XC4VSX55-10FFG1148C**



Virtex-4 FPGA Electrical Characteristics

Virtex®-4 FPGAs are available in -12, -11, and -10 speed grades, with -12 having the highest performance.

Virtex-4 FPGA DC and AC characteristics are specified for both commercial and industrial grades. Except the operating temperature range or unless otherwise noted, all the DC and AC electrical parameters are the same for a particular speed grade (that is, the timing characteristics of a -10 speed grade industrial device are the same as for a -10 speed grade commercial device). However, only selected speed grades and/or devices might be available in the industrial range.

All supply voltage and junction temperature specifications are representative of worst-case conditions. The parameters included are common to popular designs and typical applications.

This Virtex-4 FPGA Data Sheet is part of an overall set of documentation on the Virtex-4 family of FPGAs that is available on the Xilinx website:

- *Virtex-4 Family Overview*, [DS112](#)
- *Virtex-4 FPGA User Guide*, [UG070](#)
- *Virtex-4 FPGA Configuration Guide*, [UG071](#)
- *XtremeDSP for Virtex-4 FPGAs User Guide*, [UG073](#)
- *Virtex-4 FPGA Packaging and Pinout Specification*, [UG075](#)
- *Virtex-4 FPGA PCB Designer's Guide*, [UG072](#)
- *Virtex-4 RocketIO™ Multi-Gigabit Transceiver User Guide*, [UG076](#)
- *Virtex-4 FPGA Embedded Tri-Mode Ethernet MAC User Guide*, [UG074](#)
- *PowerPC® 405 Processor Block Reference Guide*, [UG018](#)

All specifications are subject to change without notice.

Virtex-4 FPGA DC Characteristics

Table 1: Absolute Maximum Ratings

Symbol	Description		Units
V_{CCINT}	Internal supply voltage relative to GND	-0.5 to 1.32	V
V_{CCAUX}	Auxiliary supply voltage relative to GND	-0.5 to 3.0	V
V_{CCO}	Output drivers supply voltage relative to GND	-0.5 to 3.75	V
V_{BATT}	Key memory battery backup supply	-0.5 to 4.05	V
V_{REF}	Input reference voltage	-0.3 to 3.75	V
V_{IN}	I/O input voltage relative to GND (all user and dedicated I/Os)	-0.75 to 4.05	V
	I/O input voltage relative to GND (restricted to maximum of 100 user I/Os) ^(3,4)	-0.95 to 4.4 (Commercial Temperature) -0.85 to 4.3 (Industrial Temperature)	V
	2.5V or below I/O input voltage relative to GND (user and dedicated I/Os)	-0.75 to $V_{CCO} + 0.5$	V
I_{IN}	Current applied to an I/O pin, powered or unpowered	±100	mA
	Total current applied to all I/O pins, powered or unpowered	±200	mA

Table 1: Absolute Maximum Ratings (Continued)

Symbol	Description		Units
V _{TS}	Voltage applied to 3-state 3.3V output (all user and dedicated I/Os)	-0.75 to 4.05	V
	Voltage applied to 3-state 3.3V output (restricted to maximum of 100 user I/Os) ^(3,4)	-0.95 to 4.4 (Commercial Temperature) -0.85 to 4.3 (Industrial Temperature)	V
	2.5V or below I/O input voltage relative to GND (user and dedicated I/Os)	-0.75 to V _{CCO} + 0.5	V
AVCCAUXRX	Receive auxiliary supply voltage relative to analog ground, GNDA (RocketIO pins)	-0.5 to 1.32	V
AVCCAUTX	Transmit auxiliary supply voltage relative to analog ground, GNDA (RocketIO pins)	-0.5 to 1.32	V
AVCCAUXMGT	Management auxiliary supply voltage relative to analog ground, GNDA (RocketIO pins)	-0.5 to 3.0	V
V _{TRX}	Terminal receive supply voltage relative to GND	-0.5 to 3.0	V
V _{TTX}	Terminal transmit supply voltage relative to GND	-0.5 to 1.65	V
T _{STG}	Storage temperature (ambient)	-65 to 150	°C
T _{SOL}	Maximum soldering temperature ⁽²⁾	+220	°C
T _J	Maximum junction temperature ⁽²⁾	+125	°C

Notes:

- Stresses beyond those listed under Absolute Maximum Ratings might cause permanent damage to the device. These are stress ratings only, and functional operation of the device at these or any other conditions beyond those listed under Operating Conditions is not implied. Exposure to Absolute Maximum Ratings conditions for extended periods of time might affect device reliability.
- For soldering guidelines and thermal considerations, see the [Virtex-4 Packaging and Pinout Specification](#) on the Xilinx website.
- When using more than 100 3.3V I/Os, refer to the [Virtex-4 FPGA User Guide](#), Chapter 6, "3.3V I/O Design Guidelines."
- For more flexibility in specific designs, a maximum of 100 user I/Os can be stressed beyond the normal spec for no more than 20% of a data period. There are no bank restrictions.

Table 2: Recommended Operating Conditions

Symbol	Description		Min	Max	Units
V _{CCINT}	Internal supply voltage relative to GND, T _J = 0° C to +85° C	Commercial	1.14	1.26	V
	Internal supply voltage relative to GND, T _J = -40° C to +100° C	Industrial	1.14	1.26	V
V _{CCAUX}	Auxiliary supply voltage relative to GND, T _J = 0° C to +85° C	Commercial	2.375	2.625	V
	Auxiliary supply voltage relative to GND, T _J = -40° C to +100° C	Industrial	2.375	2.625	V
V _{CCO} ^(1,3,4,5)	Supply voltage relative to GND, T _J = 0° C to +85° C	Commercial	1.14	3.45	V
	Supply voltage relative to GND, T _J = -40° C to +100° C	Industrial	1.14	3.45	V
V _{IN}	3.3V supply voltage relative to GND, T _J = 0° C to +85° C	Commercial	GND - 0.20	3.45	V
	3.3V supply voltage relative to GND, T _J = -40° C to +100° C	Industrial	GND - 0.20	3.45	V
	2.5V and below supply voltage relative to GND, T _J = 0° C to +85° C	Commercial	GND - 0.20	V _{CCO} + 0.2	V
	2.5V and below supply voltage relative to GND, T _J = -40° C to +100° C	Industrial	GND - 0.20	V _{CCO} + 0.2	V
I _{IN}	Maximum current through any pin in a powered or unpowered bank when forward biasing the clamp diode.	Commercial		10	mA
		Industrial		10	mA
V _{BATT} ⁽²⁾	Battery voltage relative to GND, T _J = 0° C to +85° C	Commercial	1.0	3.6	V
	Battery voltage relative to GND, T _J = -40° C to +100° C	Industrial	1.0	3.6	V

Table 2: Recommended Operating Conditions (Continued)

Symbol	Description		Min	Max	Units
AVCCAUXRX ⁽⁶⁾	Auxiliary receive supply voltage relative to GNDA	Commercial	1.14	1.26	V
		Industrial	1.14	1.26	V
AVCCAUTX ⁽⁶⁾	Auxiliary transmit supply voltage relative to GNDA	Commercial	1.14	1.26	V
		Industrial	1.14	1.26	V
AVCCAUXMGT	Auxiliary management supply voltage relative to GNDA	Commercial	2.375	2.625	V
		Industrial	2.375	2.625	V
V _{TRX} ⁽⁷⁾	Terminal receive supply voltage relative to GND	Commercial	0.25	2.5	V
		Industrial	0.25	2.5	V
V _{TTX}	Terminal transmit supply voltage relative to GND	Commercial	1.14	1.575	V
		Industrial	1.14	1.575	V

Notes:

1. Configuration data is retained even if V_{CCO} drops to 0V.
2. V_{BATT} is required only when using bitstream encryption. If battery is not used, connect V_{BATT} to either ground or V_{CCAUX}.
3. For 3.3V I/O operation, refer to the [Virtex-4 FPGA User Guide](#).
4. Includes V_{CCO} of 1.2V, 1.5V, 1.8V, 2.5V, and 3.3V
5. The configuration output supply voltage V_{CC_CONFIG} is also known as V_{CCO_0}
6. IMPORTANT! All unused RocketIO transceivers must be connected to power and GND. When using RocketIO transceivers, refer to the power filtering section of the [Virtex-4 RocketIO Multi-Gigabit Transceiver User Guide](#). Unused transceivers must be powered by an appropriate voltage level source. Passive filtering must meet the requirements discussed in the [Virtex-4 RocketIO Multi-Gigabit Transceiver User Guide](#).
7. Internal AC coupling is enabled.

Table 3: DC Characteristics Over Recommended Operating Conditions

Symbol	Description	Data Rate (Gb/s)	Min	Typ	Max	Units
V _{DRINT}	Data retention V _{CCINT} voltage (below which configuration data might be lost)		0.9			V
V _{DRI}	Data retention V _{CCAUX} voltage (below which configuration data might be lost)		2.0			V
I _{REF}	V _{REF} current per pin				10	µA
I _L	Input or output leakage current per pin (sample-tested)				10	µA
C _{IN}	Input capacitance (sample-tested)				10	pF
I _{RPU} ⁽¹⁾	Pad pull-up (when selected) @ V _{IN} = 0V, V _{CCO} = 3.3V		5		200	µA
	Pad pull-up (when selected) @ V _{IN} = 0V, V _{CCO} = 3.0V		5		125	µA
	Pad pull-up (when selected) @ V _{IN} = 0V, V _{CCO} = 2.5V		5		120	µA
	Pad pull-up (when selected) @ V _{IN} = 0V, V _{CCO} = 1.8V		5		60	µA
	Pad pull-up (when selected) @ V _{IN} = 0V, V _{CCO} = 1.5V		5		40	µA
I _{RPD} ⁽¹⁾	Pad pull-down (when selected) @ V _{IN} = V _{CCO}		5		100	µA
I _{BATT} ⁽¹⁾	Battery supply current			75	100	nA
I _{CCAUXRX} ⁽²⁾	Operating AVCCAUXRX supply current	6.5		292	427	mA
		5.0		302	485	mA
		4.25		291	446	mA
		3.125		279	382	mA
		1.25/2.5		263	351	mA
		1.25 Digital RX		314	432	mA

Table 3: DC Characteristics Over Recommended Operating Conditions (Continued)

Symbol	Description	Data Rate (Gb/s)	Min	Typ	Max	Units
$I_{CCAUXTX}^{(2)}$	Operating AVCCAUXTX supply current	6.5		170	339	mA
		5.0		180	355	mA
		4.25		173	330	mA
		3.125		165	307	mA
		2.5		157	298	mA
		1.25		151	295	mA
$I_{CCAUXMGT}^{(2)}$	Operating AVCCAUXMGT supply current			3	5	mA
$I_{TTX}^{(2)}$	Operating I_{TTX} supply current when transmitter is AC coupled or $V_{TTX} = V_{TRX}$			100	210	mA
$I_{TRX}^{(2,3)}$	Operating I_{TRX} supply current when receiver is AC coupled or $V_{TTX} = V_{TRX}$			12	24	mA
n	Temperature diode ideality factor			1.02		n
P_{CPU}	Power dissipation of PowerPC 405 processor block			0.45		mW/MHz
r	Series resistance			2		Ω

Notes:

1. Values are specified at nominal voltage, 25°C.
2. Typical I_{CC} numbers given *per tile* with both MGTs operating with default settings. Maximum I_{CC} numbers given per tile with both MGTs operating with maximum amplitude and emphasis settings.
3. Varies with AC / DC coupling.

Table 4: Quiescent Supply Current

Symbol	Description	Device	Typ ⁽¹⁾	Max	Units
I_{CCINTQ}	Quiescent V_{CCINT} supply current	XC4VLX15	46	Note (6)	mA
		XC4VLX25	77	Note (6)	mA
		XC4VLX40	121	Note (6)	mA
		XC4VLX60	167	Note (6)	mA
		XC4VLX80	220	Note (6)	mA
		XC4VLX100	292	Note (6)	mA
		XC4VLX160	384	Note (6)	mA
		XC4VLX200	489	Note (6)	mA
		XC4VSX25	94	Note (6)	mA
		XC4VSX35	140	Note (6)	mA
		XC4VSX55	271	Note (6)	mA
		XC4VFX12	47	Note (6)	mA
		XC4VFX20	71	Note (6)	mA
		XC4VFX40	139	Note (6)	mA
		XC4VFX60	203	Note (6)	mA
		XC4VFX100	311	Note (6)	mA
		XC4VFX140	442	Note (6)	mA

Table 4: Quiescent Supply Current (Continued)

Symbol	Description	Device	Typ ⁽¹⁾	Max	Units
I _{CCOQ}	Quiescent V _{CCO} supply current	XC4VLX15	1.25	Note (6)	mA
		XC4VLX25	1.25	Note (6)	mA
		XC4VLX40	1.25	Note (6)	mA
		XC4VLX60	1.5	Note (6)	mA
		XC4VLX80	1.5	Note (6)	mA
		XC4VLX100	1.75	Note (6)	mA
		XC4VLX160	2.5	Note (6)	mA
		XC4VLX200	2.5	Note (6)	mA
		XC4VSX25	1.25	Note (6)	mA
		XC4VSX35	1.25	Note (6)	mA
		XC4VSX55	1.5	Note (6)	mA
		XC4VFX12	1.25	Note (6)	mA
		XC4VFX20	1.25	Note (6)	mA
		XC4VFX40	1.25	Note (6)	mA
		XC4VFX60	1.5	Note (6)	mA
		XC4VFX100	1.75	Note (6)	mA
		XC4VFX140	2.5	Note (6)	mA
I _{CCAUXQ}	Quiescent V _{CCAUX} supply current	XC4VLX15	31	Note (6)	mA
		XC4VLX25	36	Note (6)	mA
		XC4VLX40	43	Note (6)	mA
		XC4VLX60	74	Note (6)	mA
		XC4VLX80	83	Note (6)	mA
		XC4VLX100	95	Note (6)	mA
		XC4VLX160	133	Note (6)	mA
		XC4VLX200	150	Note (6)	mA
		XC4VSX25	62	Note (6)	mA
		XC4VSX35	70	Note (6)	mA
		XC4VSX55	91	Note (6)	mA
		XC4VFX12	31	Note (6)	mA
		XC4VFX20	35	Note (6)	mA
		XC4VFX40	69	Note (6)	mA
		XC4VFX60	80	Note (6)	mA
		XC4VFX100	98	Note (6)	mA
		XC4VFX140	143	Note (6)	mA
I _{CCAUXRX} ⁽⁴⁾	Quiescent AV _{CCAUXRX} supply current	XC4VFX20	25	154	mA
		XC4VFX60	35	154	mA
		XC4VFX100	50	154	mA

Table 4: Quiescent Supply Current (Continued)

Symbol	Description	Device	Typ ⁽¹⁾	Max	Units
$I_{CCAUXTX}^{(4)}$	Quiescent AVCCAUXTX supply current	XC4VFX20	10	44	mA
		XC4VFX60	15	44	mA
		XC4VFX100	20	44	mA
$I_{TTX}^{(4,5)}$	Quiescent V_{TTX} supply current	XC4VFX20	1	2	mA
		XC4VFX60	1	2	mA
		XC4VFX100	1	2	mA
$I_{TRX}^{(4,5)}$	Quiescent V_{TRX} supply current	XC4VFX20	1	2	mA
		XC4VFX60	1	2	mA
		XC4VFX100	1	2	mA
$I_{AUXMGT}^{(4)}$	Quiescent V_{AUXMGT} supply current	XC4VFX20	1	2	mA
		XC4VFX60	1	2	mA
		XC4VFX100	1	2	mA

Notes:

1. Typical values are specified at nominal voltage, 25°C.
2. Typical values are for blank configured devices with no output current loads, no active input pull-up resistors, all I/O pins are 3-state and floating.
3. If DCI or differential signaling is used, more accurate quiescent current estimates can be obtained by using the Power Estimator or XPower tool.
4. Given for entire die. Powered and unconfigured.
5. Unconnected (if channel is driven to voltage).
6. Use the XPower Estimator (XPE) tool to calculate maximum static power for specific process, voltage, and temperature conditions.

Power-On Power Supply Requirements

Xilinx® FPGAs require a certain amount of supply current during power-on to insure proper device initialization. The actual current consumed depends on the power-on ramp rate of the power supply.

The power supplies can be turned on in any sequence, though the specifications shown in Table 5 are for the recommended power-on sequence of V_{CCINT} , V_{CCAUX} , V_{CCO} . Xilinx does not specify the current for other power-on sequences.

Table 5 shows the minimum current required by Virtex-4 devices for proper power-on and configuration.

If the current minimums shown in Table 5 are met, the device powers on properly after all three supplies have passed through their power-on reset threshold voltages.

Once initialized and configured, use the XPower tool to estimate current drain on these supplies.

Table 5: Power-On Current for Virtex-4 Devices

Device	$I_{CCINTMIN}$		$I_{CCAUXMIN}$		I_{CCOMIN}		Units
	Typ ⁽¹⁾	Max ⁽²⁾	Typ ⁽¹⁾	Max ⁽²⁾	Typ ⁽¹⁾	Max ⁽²⁾	
XC4VLX15	110	750	60	100	50	75	mA
XC4VLX25	160	1350	85	125	75	100	mA
XC4VLX40	250	1500	110	150	75	105	mA
XC4VLX60	300	1925	225	300	150	250	mA
XC4VLX80	400	2550	280	350	150	275	mA
XC4VLX100	500	3200	335	425	200	300	mA
XC4VLX160	700	3700	500	600	250	400	mA
XC4VLX200	850	3850	500	600	250	400	mA
XC4VSX25	175	725	110	150	75	105	mA
XC4VSX35	250	1350	165	200	100	150	mA
XC4VSX55	400	2225	225	300	150	225	mA
XC4VFX12	111	750	56	100	50	75	mA
XC4VFX20	151	1100	56	100	75	125	mA
XC4VFX40	244	1650	167	250	125	225	mA
XC4VFX60	339	2250	222	350	150	275	mA
XC4VFX100	511	3300	278	500	200	300	mA
XC4VFX140	702	4250	500	825	250	375	mA

Notes:

1. Typical values are specified at nominal voltage, 25°C.
2. Maximum values are specified under worst-case process, voltage, and temperature conditions.

Table 6: Power Supply Ramp Time

Symbol	Description	Ramp Time	Units
V_{CCINT}	Internal supply voltage relative to GND	0.20 to 50.0	ms
V_{CCO}	Output drivers supply voltage relative to GND	0.20 to 50.0	ms
V_{CCAUX}	Auxiliary supply voltage relative to GND	0.20 to 50.0	ms

SelectIO™ DC Input and Output Levels

Values for V_{IL} and V_{IH} are recommended input voltages. Values for I_{OL} and I_{OH} are guaranteed over the recommended operating conditions at the V_{OL} and V_{OH} test points. Only selected standards are tested. These are chosen to ensure that all standards meet their specifications.

The selected standards are tested at a minimum V_{CCO} with the respective V_{OL} and V_{OH} voltage levels shown. Other standards are sample tested.

Table 7: SelectIO DC Input and Output Levels

IOSTANDARD Attribute	V_{IL}		V_{IH}		V_{OL}	V_{OH}	I_{OL}	I_{OH}
	V, Min	V, Max	V, Min	V, Max	V, Max	V, Min	mA	mA
LVTTTL	-0.2	0.8	2.0	3.45	0.4	2.4	Note(3)	Note(3)
LVC MOS33, LVDCI33	-0.2	0.8	2.0	3.45	0.4	$V_{CCO} - 0.4$	Note(3)	Note(3)
LVC MOS25, LVDCI25	-0.3	0.7	1.7	$V_{CCO} + 0.3$	0.4	$V_{CCO} - 0.4$	Note(3)	Note(3)
LVC MOS18, LVDCI18	-0.3	$35\% V_{CCO}$	$65\% V_{CCO}$	$V_{CCO} + 0.3$	0.4	$V_{CCO} - 0.45$	Note(4)	Note(4)
LVC MOS15, LVDCI15	-0.3	$35\% V_{CCO}$	$65\% V_{CCO}$	$V_{CCO} + 0.3$	0.4	$V_{CCO} - 0.45$	Note(4)	Note(4)
PCI33_3 ⁽⁵⁾	-0.2	$30\% V_{CCO}$	$50\% V_{CCO}$	V_{CCO}	$10\% V_{CCO}$	$90\% V_{CCO}$	1.5	-0.5
PCI66_3 ⁽⁵⁾	-0.2	$30\% V_{CCO}$	$50\% V_{CCO}$	V_{CCO}	$10\% V_{CCO}$	$90\% V_{CCO}$	1.5	-0.5
PCI-X ⁽⁵⁾	-0.2	$35\% V_{CCO}$	$50\% V_{CCO}$	V_{CCO}	$10\% V_{CCO}$	$90\% V_{CCO}$	1.5	-0.5
GTL P	-0.3	$V_{REF} - 0.1$	$V_{REF} + 0.1$	-	0.6	N/A	36	N/A
GTL	-0.3	$V_{REF} - 0.05$	$V_{REF} + 0.05$	-	0.4	N/A	32	N/A
HSTL I ⁽²⁾	-0.3	$V_{REF} - 0.1$	$V_{REF} + 0.1$	$V_{CCO} + 0.3$	0.4	$V_{CCO} - 0.4$	8	-8
HSTL II ⁽²⁾	-0.3	$V_{REF} - 0.1$	$V_{REF} + 0.1$	$V_{CCO} + 0.3$	0.4	$V_{CCO} - 0.4$	16	-16
HSTL III ⁽²⁾	-0.3	$V_{REF} - 0.1$	$V_{REF} + 0.1$	$V_{CCO} + 0.3$	0.4	$V_{CCO} - 0.4$	24	-8
HSTL IV ⁽²⁾	-0.3	$V_{REF} - 0.1$	$V_{REF} + 0.1$	$V_{CCO} + 0.3$	0.4	$V_{CCO} - 0.4$	48	-8
DIFF HSTL II ⁽²⁾	-0.3	$50\% V_{CCO} - 0.1$	$50\% V_{CCO} + 0.1$	$V_{CCO} + 0.3$	0.4	$V_{CCO} - 0.4$	-	-
SSTL2 I	-0.3	$V_{REF} - 0.15$	$V_{REF} + 0.15$	$V_{CCO} + 0.3$	$V_{TT} - 0.61$	$V_{TT} + 0.61$	8.1	-8.1
SSTL2 II	-0.3	$V_{REF} - 0.15$	$V_{REF} + 0.15$	$V_{CCO} + 0.3$	$V_{TT} - 0.81$	$V_{TT} + 0.81$	16.2	-16.2
DIFF SSTL2 II	-0.3	$50\% V_{CCO} - 0.15$	$50\% V_{CCO} + 0.15$	$V_{CCO} + 0.3$	0.5	$V_{CCO} - 0.5$	-	-
SSTL18 I	-0.3	$V_{REF} - 0.125$	$V_{REF} + 0.125$	$V_{CCO} + 0.3$	$V_{TT} - 0.47$	$V_{TT} + 0.47$	6.7	-6.7
SSTL18 II	-0.3	$V_{REF} - 0.125$	$V_{REF} + 0.125$	$V_{CCO} + 0.3$	$V_{TT} - 0.60$	$V_{TT} + 0.60$	13.4	-13.4
DIFF SSTL18 II	-0.3	$50\% V_{CCO} - 0.125$	$50\% V_{CCO} + 0.125$	$V_{CCO} + 0.3$	0.4	$V_{CCO} - 0.4$	-	-

Notes:

1. Tested according to relevant specifications.
2. Applies to both 1.5V and 1.8V HSTL.
3. LVC MOS using drive strengths of 2, 4, 6, 8, 12, 16, or 24 mA.
4. LVC MOS using drive strengths of 2, 4, 6, 8, 12, or 16 mA.
5. For more information on PCI33_3, PCI66_3, and PCI-X, refer to the [Virtex-4 FPGA User Guide](#), *SelectIO Resources*, Chapter 6.

LDT DC Specifications (LDT_25)

Table 8: LDT DC Specifications

Symbol	DC Parameter	Conditions	Min	Typ	Max	Units
V_{CC0}	Supply Voltage		2.38	2.5	2.63	V
V_{OD}	Differential Output Voltage ^(1,2)	$R_T = 100\Omega$ across Q and \bar{Q} signals	495	600	715	mV
ΔV_{OD}	Change in V_{OD} Magnitude		-15		15	mV
V_{OCM}	Output Common Mode Voltage	$R_T = 100\Omega$ across Q and \bar{Q} signals	495	600	715	mV
ΔV_{OCM}	Change in V_{OCM} Magnitude		-15		15	mV
V_{ID}	Input Differential Voltage		200	600	1000	mV
ΔV_{ID}	Change in V_{ID} Magnitude		-15		15	mV
V_{ICM}	Input Common Mode Voltage		440	600	780	mV
ΔV_{ICM}	Change in V_{ICM} Magnitude		-15		15	mV

Notes:

1. Recommended input maximum voltage not to exceed $V_{CC0} + 0.2V$.
2. Recommended input minimum voltage not to go below $-0.5V$.

LVDS DC Specifications (LVDS_25)

Table 9: LVDS DC Specifications

Symbol	DC Parameter	Conditions	Min	Typ	Max	Units
V_{CC0}	Supply Voltage		2.38	2.5	2.63	V
V_{OH}	Output High Voltage for Q and \bar{Q}	$R_T = 100\Omega$ across Q and \bar{Q} signals			1.602	V
V_{OL}	Output Low Voltage for Q and \bar{Q}	$R_T = 100\Omega$ across Q and \bar{Q} signals	0.898			V
V_{ODIFF}	Differential Output Voltage ^(1,2) (Q - \bar{Q}), Q = High (\bar{Q} - Q), \bar{Q} = High	$R_T = 100\Omega$ across Q and \bar{Q} signals	247	350	454	mV
V_{OCM}	Output Common-Mode Voltage	$R_T = 100\Omega$ across Q and \bar{Q} signals	1.125	1.250	1.375	V
V_{IDIFF}	Differential Input Voltage (Q - \bar{Q}), Q = High (\bar{Q} - Q), \bar{Q} = High		100	350	600	mV
V_{ICM}	Input Common-Mode Voltage		0.3	1.2	2.2	V

Notes:

1. Recommended input maximum voltage not to exceed $V_{CC0} + 0.2V$.
2. Recommended input minimum voltage not to go below $-0.5V$.

Extended LVDS DC Specifications (LVDS_EXT_25)

Table 10: Extended LVDS DC Specifications

Symbol	DC Parameter	Conditions	Min	Typ	Max	Units
V_{CC0}	Supply Voltage		2.38	2.5	2.63	V
V_{OH}	Output High Voltage for Q and \bar{Q}	$R_T = 100\Omega$ across Q and \bar{Q} signals	–	–	1.785	V
V_{OL}	Output Low Voltage for Q and \bar{Q}	$R_T = 100\Omega$ across Q and \bar{Q} signals	0.715	–	–	V
V_{ODIFF}	Differential Output Voltage (Q – \bar{Q}), Q = High (\bar{Q} – Q), \bar{Q} = High	$R_T = 100\Omega$ across Q and \bar{Q} signals	440	–	820	mV
V_{OCM}	Output Common-Mode Voltage	$R_T = 100\Omega$ across Q and \bar{Q} signals	1.125	1.250	1.375	V
V_{IDIFF}	Differential Input Voltage ^(1,2) (Q – \bar{Q}), Q = High (\bar{Q} – Q), \bar{Q} = High	Common-mode input voltage = 1.25V	100	–	1000	mV
V_{ICM}	Input Common-Mode Voltage	Differential input voltage = ± 350 mV	0.3	1.2	2.2	V

Notes:

1. Recommended input maximum voltage not to exceed $V_{CC0} + 0.2V$.
2. Recommended input minimum voltage not to go below $-0.5V$.

LVPECL DC Specifications (LVPECL_25)

These values are valid when driving a 100Ω differential load only, i.e., a 100Ω resistor between the two receiver pins. The V_{OH} levels are 200 mV below standard LVPECL levels and are compatible with devices tolerant of lower com-

mon-mode ranges. Table 11 summarizes the DC output specifications of LVPECL. For more information on using LVPECL, see the *Virtex-4 FPGA User Guide: Chapter 6, SelectIO Resources*.

Table 11: LVPECL DC Specifications

Symbol	DC Parameter	Min	Typ	Max	Units
V_{OH}	Output High Voltage	$V_{CC} - 1.025$	1.545	$V_{CC} - 0.88$	V
V_{OL}	Output Low Voltage	$V_{CC} - 1.81$	0.795	$V_{CC} - 1.62$	V
V_{ICM}	Input Common-Mode Voltage	0.6		2.2	V
V_{IDIFF}	Differential Input Voltage ^(1,2)	0.100		1.5	V

Notes:

1. Recommended input maximum voltage not to exceed $V_{CC0} + 0.2V$.
2. Recommended input minimum voltage not to go below $-0.5V$.

RocketIO DC Input and Output Levels

Table 12 summarizes the DC input and output specifications of the Virtex-4 FPGA RocketIO Multi-Gigabit Serial Transceivers. Figure 1 shows the single-ended output voltage

swing. Figure 2 shows the peak-to-peak differential output voltage. Consult the [Virtex-4 RocketIO Multi-Gigabit Transceiver User Guide](#) for further details.

Table 12: RocketIO DC Specifications

DC Parameter	Symbol	Conditions	Min	Typ	Max	Units
Peak-to-Peak Differential Input Voltage	DV_{IN}	Internal AC Coupled	110		2400	mV
Single-Ended Input Range	SE_{VIN}	Internal AC Coupled	0		V_{TRX}	mV
Common Mode Input Voltage Range	V_{ICM}	Internal AC Coupled	100		$V_{TRX} - 100$	mV
		Bypassed Internal AC Coupled (1)		800		mV
Single-Ended Output Voltage Swing(2, 3)	V_{OUT}		450		725	mV
Common Mode Output Voltage Range(3)	V_{TCM}			1000		mV
Peak-to-Peak Differential Output Voltage(2, 3)	DV_{PPOUT}		900	1050	1400	mV
Signal detect threshold	$RXOVB_{VDPP}$	RX		TBD		
Electrical idle amplitude	$TXOVB_{VDPP}$	TX		65		mV
RocketIO MGT Clock DC Input Levels						
Peak-to-Peak Differential Input Voltage	V_{IDIFF}	$2 \times V_{MGTCLKP} - V_{MGTCKLN} $	100	600	2000	mV
Differential Input Resistance	R_{IN}		71	105	124	Ω

Notes:

1. The maximum V_{TRX} is 1.26V when bypassing the internal AC coupled V_{ICM} . V_{TRX} must be less than or equal to $AVCCAUXRX$.
2. The output swing and pre-emphasis levels are selected using the attributes discussed in Chapter 4: PMA Analog Considerations in the [Virtex-4 RocketIO Multi-Gigabit Transceiver User Guide](#) for details.
3. V_{TTX} is $1.5 \pm 5\%$; different amplitudes possible with adjusted DAC values.

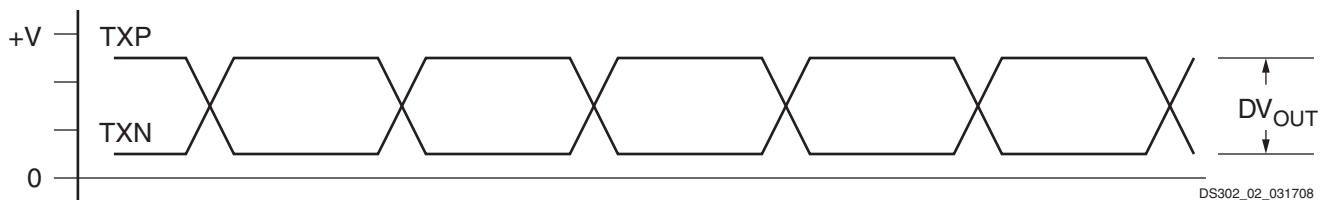

Figure 1: Single-Ended Output Voltage Swing

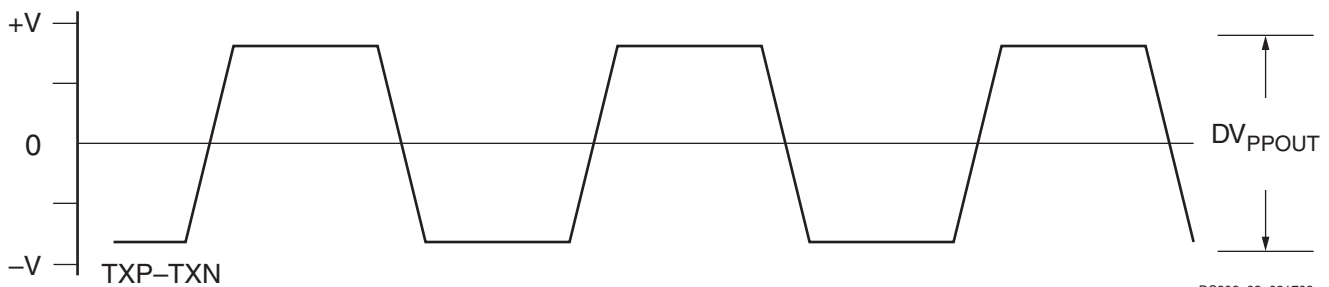

Figure 2: Peak-to-Peak Differential Output Voltage

Interface Performance Characteristics

Table 13: Interface Performance

Description	Speed Grade		
	-12	-11	-10
Networking Applications			
SFI-4.1 (SDR LVDS Interface) ⁽¹⁾	710 MHz	710 MHz	645 MHz
SPI-4.2 (DDR LVDS Interface)	1 Gb/s	1 Gb/s	800 Mb/s
Memory Interfaces			
DDR2 SDRAM (High-Performance SERDES Design) ⁽²⁾	600 Mb/s	533 Mb/s	500 Mb/s
DDR2 SDRAM (Low-Latency Direct Clocking Design) ⁽³⁾	420 Mb/s	410 Mb/s	400 Mb/s
QDR II SRAM (Low-Latency Direct Clocking Design) ⁽⁴⁾	550 Mb/s	500 Mb/s	400 Mb/s
DDR SDRAM (Low-Latency Direct Clocking Design) ⁽⁵⁾	344 Mb/s	336 Mb/s	330 Mb/s
RLDRAM II (Low-Latency Direct Clocking Design) ⁽⁶⁾	470 Mb/s	470 Mb/s	400 Mb/s

Notes:

1. Input clocks above 622 MHz require AC coupling.
2. Performance defined using design implementation described in application note [XAPP721](#), *High-Performance DDR2 SDRAM Interface Data Capture Using ISERDES and OSERDES*.
3. Performance defined using design implementation described in application note [XAPP702](#), *DDR2 Controller Using Virtex-4 Devices*.
4. Performance defined using design implementation described in application note [XAPP703](#), *QDR II SRAM Interface for Virtex-4 Devices*.
5. Performance defined using design implementation described in application note [XAPP709](#), *DDR SDRAM Controller Using Virtex-4 FPGA Devices*.
6. Performance defined using design implementation described in application note [XAPP710](#), *Synthesizable CIO DDR RLDRAM II Controller for Virtex-4 FPGAs*.

Switching Characteristics

Switching characteristics are specified on a per-speed-grade basis and can be designated as Advance, Preliminary, or Production. Each designation is defined as follows:

Advance

These specifications are based on simulations only and are typically available soon after device design specifications are frozen. Although speed grades with this designation are considered relatively stable and conservative, some under-reporting might still occur.

Preliminary

These specifications are based on complete ES (engineering sample) silicon characterization. Devices and speed grades with this designation are intended to give a better indication of the expected performance of production silicon. The probability of under-reporting delays is greatly reduced as compared to Advance data.

Production

These specifications are released once enough production silicon of a particular device family member has been characterized to provide full correlation between specifications and devices over numerous production lots. There is no under-reporting of delays, and customers receive formal notification of any subsequent changes. Typically, the slowest speed grades transition to Production before faster speed grades.

Table 14 correlates the current status of each Virtex-4 device with a corresponding speed specification version 1.68 designation.

Table 14: Virtex-4 Device Speed Grade Designations

Device	Speed Grade Designations		
	Advance	Preliminary	Production
XC4VLX15			-12, -11, -10
XC4VLX25			-12, -11, -10
XC4VLX40			-12, -11, -10
XC4VLX60			-12, -11, -10
XC4VLX80			-12, -11, -10
XC4VLX100			-12, -11, -10
XC4VLX160			-12, -11, -10
XC4VLX200			-11, -10
XC4VSX25			-12, -11, -10
XC4VSX35			-12, -11, -10
XC4VSX55			-12, -11, -10
XC4VFX12			-12, -11, -10
XC4VFX20			-12, -11, -10
XC4VFX40			-12, -11, -10
XC4VFX60			-12, -11, -10
XC4VFX100			-12, -11, -10
XC4VFX140			-11, -10

Since individual family members are produced at different times, the migration from one category to another depends completely on the status of the fabrication process for each device.

All specifications are always representative of worst-case supply voltage and junction temperature conditions.

Testing of Switching Characteristics

All devices are 100% functionally tested. Internal timing parameters are derived from measuring internal test patterns. Listed below are representative values. For more specific, more precise, and worst-case guaranteed data,

use the values reported by the static timing analyzer (TRCE in the Xilinx Development System) and back-annotate to the simulation net list. Unless otherwise noted, values apply to all Virtex-4 devices.

PowerPC Switching Characteristics

Consult the [PowerPC 405 Processor Block Reference Guide](#) for further information.

Table 15: PowerPC 405 Processor Clocks Absolute AC Characteristics

Description	Speed Grade						Units
	-12		-11		-10		
	Min	Max	Min	Max	Min	Max	
Characteristics when APU Not Used							
CPMC405CLOCK frequency ^(1,4)	0	450	0	400	0	350	MHz
CPMDCRCLK ⁽³⁾	0	450	0	400	0	350	MHz
CPMFCMCLK ⁽³⁾	NA	NA	NA	NA	NA	NA	MHz
JTAGC405TCK frequency ⁽²⁾	0	225	0	200	0	175	MHz
PLBCLK ⁽³⁾	0	450	0	400	0	350	MHz
BRAMDSOCMCLK ⁽³⁾	0	450	0	400	0	350	MHz
BRAMISOCMCLK ⁽³⁾	0	450	0	400	0	350	MHz
Characteristics when APU Used							
CPMC405CLOCK frequency ^(1,4)	0	333	0	275	0	233	MHz
CPMDCRCLK ⁽³⁾	0	333	0	275	0	233	MHz
CPMFCMCLK ⁽³⁾	0	333	0	275	0	233	MHz
JTAGC405TCK frequency ⁽²⁾	0	166.5	0	137.5	0	116.5	MHz
PLBCLK ⁽³⁾	0	333	0	275	0	233	MHz
BRAMDSOCMCLK ⁽³⁾	0	333	0	275	0	233	MHz
BRAMISOCMCLK ⁽³⁾	0	333	0	275	0	233	MHz

Notes:

1. Worst-case DCM output clock jitter is included in these specifications.
2. The theoretical maximum frequency of this clock is one-half the CPMC405CLOCK. However, the achievable maximum is system dependent, and will be much less.
3. The theoretical maximum frequency of these clocks is equal to the CPMC405CLOCK. Integer clock ratios are required for the CPMC405CLOCK and BRAMDSOCMCLK, CPMC405CLOCK and BRAMISOCMCLK, CPMC405CLOCK and CPMDCRCLK, CPMC405CLOCK and CPMFCMCLK, and CPMC405CLOCK and PLBCLK. The integer ratios can be different for each interface. However, the achievable maximum is system dependent.
4. Maximum operating frequency of CPMC405CLOCK is specified with the input pin TIEC405DISOPERANDFWD connected to a logic 1.

Table 16: Processor Block Switching Characteristics

Description	Symbol	Speed Grade			Units
		-12	-11	-10	
Setup and Hold Relative to Clock (CPMC405CLOCK)					
Clock and Power Management control inputs	T _{PPCDCK_CORECKI} / T _{PPCCKD_CORECKI}	0.60 0.20	0.65 0.20	0.74 0.23	ns, Min
Reset control inputs	T _{PPCDCK_RSTCHIP} / T _{PPCCKD_RSTCHIP}	0.60 0.20	0.65 0.20	0.74 0.23	ns, Min
Debug control inputs	T _{PPCDCK_EXBUSHAK} / T _{PPCCKD_EXBUSHAK}	0.60 0.20	0.65 0.20	0.74 0.23	ns, Min
Trace control inputs	T _{PPCDCK_TRCDIS} / T _{PPCCKD_TRCDIS}	0.60 0.20	0.65 0.20	0.74 0.23	ns, Min
External Interrupt Controller control inputs	T _{PPCDCK_CINPIRQ} / T _{PPCCKD_CINPIRQ}	1.04 0.20	1.15 0.20	1.40 0.23	ns, Min
Clock to Out					
Clock and Power Management control outputs	T _{PPCCKO_CORESLP}	1.35	1.51	1.74	ns, Max
Reset control outputs	T _{PPCCKO_RSTCHIP}	1.44	1.59	1.83	ns, Max
Debug control outputs	T _{PPCCKO_DBGLDAPU}	1.34	1.48	1.70	ns, Max
Trace control outputs	T _{PPCCKO_TRCCYCLE}	1.52	1.68	1.83	ns, Max
Clock					
CPMC405CLOCK minimum pulse width, High	T _{CPWH}	1.11	1.25	1.43	ns, Min
CPMC405CLOCK minimum pulse width, Low	T _{CPWL}	1.11	1.25	1.43	ns, Min

Table 17: Processor Block PLB Switching Characteristics

Description	Symbol	Speed Grade			Units
		-12	-11	-10	
Setup and Hold Relative to Clock (PLBCLK)					
Processor Local Bus (ICU/DCU) control inputs	T _{PPCDCK_ICUBUSY} / T _{PPCCKD_ICUBUSY}	0.60 0.20	0.66 0.20	0.76 0.23	ns, Min
Processor Local Bus (ICU/DCU) data inputs	T _{PPCDCK_ICURDDB} / T _{PPCCKD_ICURDDB}	0.90 0.20	1.00 0.20	1.15 0.23	ns, Min
Clock to Out					
Processor Local Bus (ICU/DCU) control outputs	T _{PPCCKO_DCUABORT}	1.61	1.78	2.05	ns, Max
Processor Local Bus (ICU/DCU) address bus outputs	T _{PPCCKO_ICUABUS}	1.66	1.85	2.13	ns, Max
Processor Local Bus (ICU/DCU) data bus outputs	T _{PPCCKO_DCUWRDBUS}	2.08	2.24	2.57	ns, Max

Table 18: Processor Block JTAG Switching Characteristics

Description	Symbol	Speed Grade			Units
		-12	-11	-10	
Setup and Hold Relative to Clock (JTAGC405TCK)					
JTAG control inputs	T _{PPCDCK_JTGTDI} / T _{PPCCKD_JTGTDI}	1.16 0.20	1.29 0.20	1.48 0.23	ns, Min
JTAG reset input	T _{PPCDCK_JTGTRSTN} / T _{PPCCKD_JTGTRSTN}	0.60 0.20	0.65 0.20	0.74 0.23	ns, Min
Clock to Out					
JTAG control outputs	T _{PPCCKO_JTGTDI}	1.68	1.79	2.14	ns, Max

Table 19: PowerPC 405 Data-Side On-Chip Memory Switching Characteristics

Description	Symbol	Speed Grade			Units
		-12	-11	-10	
Setup and Hold Relative to Clock (BRAMDSOCCLK)					
Data-Side On-Chip Memory data bus inputs	T _{PPCDCK_DSOCMRDDB}	0.60	0.65	0.74	ns, Min
	T _{PPCCKD_DSOCMRDDB}	0.20	0.20	0.23	
Clock to Out					
Data-Side On-Chip Memory control outputs	T _{PPCCKO_BRAMBWR}	2.07	2.30	2.65	ns, Max
Data-Side On-Chip Memory address bus outputs	T _{PPCCKO_BRAMABUS}	2.07	2.30	2.65	ns, Max
Data-Side On-Chip Memory data bus outputs	T _{PPCCKO_IBRAMWRDBUS01}	1.61	1.79	2.06	ns, Max

Table 20: PowerPC 405 Instruction-Side On-Chip Memory Switching Characteristics

Description	Symbol	Speed Grade			Units
		-12	-11	-10	
Setup and Hold Relative to Clock (BRAMISOCCLK)					
Instruction-Side On-Chip Memory data bus inputs	T _{PPCDCK_ISOCMRDDB}	0.74	0.82	0.94	ns, Min
	T _{PPCCKD_ISOCMRDDB}	0.20	0.20	0.23	
Clock to Out					
Instruction-Side On-Chip Memory control outputs	T _{PPCCKO_IBRAMEN}	3.04	3.37	3.88	ns, Max
Instruction-Side On-Chip Memory address bus outputs	T _{PPCCKO_IBRAMRDABUS}	1.67	1.85	2.13	ns, Max
Instruction-Side On-Chip Memory data bus outputs	T _{PPCCKO_IBRAMWRDBUS}	1.67	1.86	2.14	ns, Max

Table 21: Processor Block DCR Bus Switching Characteristics

Description	Symbol	Speed Grade			Units
		-12	-11	-10	
Setup and Hold Relative to Clock (CPMDRCLOCK)					
Device Control Register Bus control inputs	T _{PPCDCK_EXDCRACK}	0.12	0.13	0.15	ns, Min
	T _{PPCCKD_EXDCRACK}	0.15	0.17	0.19	
Device Control Register Bus data inputs	T _{PPCDCK_EXDCRDBUSI}	0.57	0.57	1.02	ns, Min
	T _{PPCCKD_EXDCRDBUSI}	0.16	0.16	0.27	
Clock to Out					
Device Control Register Bus control outputs	T _{PPCCKO_EXDCRRD}	1.20	1.35	1.54	ns, Max
Device Control Register Bus address bus outputs	T _{PPCCKO_EXDCRABUS}	1.28	1.45	1.66	ns, Max
Device Control Register Bus data bus outputs	T _{PPCCKO_EXDCRDBUSO}	1.31	1.45	1.67	ns, Max

Table 22: Processor Block APU Interface Switching Characteristics

Description	Symbol	Speed Grade			Units
		-12	-11	-10	
Setup and Hold Relative to Clock (CPMDFCMCLOCK)					
APU bus control inputs	T _{PPCDCK_DCDCREN}	0.33	0.36	0.42	ns, Min
	T _{PPCCKD_DCDCREN}	0.20	0.20	0.23	
APU bus data inputs	T _{PPCDCK_RESULT}	0.61	0.67	0.78	ns, Min
	T _{PPCCKD_RESULT}	0.20	0.20	0.23	
Clock to Out					
APU bus control outputs	T _{PPCCKO_APUFCMDEC}	1.53	1.75	2.00	ns, Max
APU bus data outputs	T _{PPCCKO_RADATA}	1.53	1.75	2.00	ns, Max

RocketIO Switching Characteristics

Consult the [Virtex-4 RocketIO Multi-Gigabit Transceiver User Guide](#) for further information.

Table 23: Maximum RocketIO Transceiver Performance

Description	Speed Grade			Units
	-12	-11	-10	
RocketIO Transceiver	6.5	6.5	3.125	Gb/s

Table 24: RocketIO Reference Clock Switching Characteristics

Description	Symbol	Conditions	Min	Typ	Max	Units
Reference Clock frequency range ⁽¹⁾	F _{GCLK}	CLK	-10 Speed Grade			MHz
			106		400	
			-11/-12 Speed Grades			MHz
			106		644	
			All Speed Grades			
GREFCLK Reference Clock frequency range ⁽¹⁾	F _{GREFCLK}	CLK	106		320	MHz
Reference Clock frequency tolerance	F _{GTOL}	CLK	-350		+350	ppm
Reference Clock rise time	T _{RCLK}	20% – 80%			400	ps
Reference Clock fall time	T _{FCLK}	20% – 80%			400	ps
Reference Clock duty cycle	T _{DCREF}	CLK	45		55	%
Reference Clock total jitter, peak-peak ⁽²⁾	T _{GJTT}	CLK			40	ps
Clock recovery frequency acquisition time	T _{LOCK}	Initial lock of the PLL from startup (programmable)		1		ms
Spread Spectrum Clocking ⁽³⁾		0% to -0.5%	30		33	kHz

Notes:

1. MGTCLK input can be used for all serial bit rates. GREFCLK can be used for serial bit rates up to 1 Gb/s.
2. Measured at the package pin. For serial rates equal to or above 1 Gb/s, MGTCLK must be used. UI = Unit Interval.
3. Tested with synchronous reference clock.

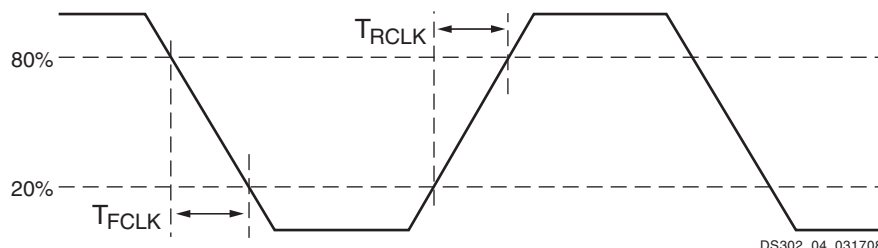

Figure 3: Reference Clock Timing Parameters

Table 25: RocketIO Receiver Switching Characteristics

Description	Symbol	Conditions			Min	Typ	Max	Units
Serial data rate, -10	F _{GRX}				0.622		3.125	Gb/s
Serial data rate, -11	F _{GRX}				0.622		6.5	Gb/s
XAUI Receive Jitter Tolerance (8B/10B CJPAT)⁽²⁾		Rate (Gb/s)	Mode⁽³⁾	Frequency				
Receive Deterministic Jitter Tolerance	T _{DJTOL}	3.125	ACDR				0.37	UI ⁽¹⁾
Receive Total Jitter Tolerance	T _{TJTOL} ⁽⁶⁾	3.125	ACDR				0.65	
Receive Sinusoidal Jitter Tolerance	T _{SJTOL} ⁽⁷⁾	3.125	ACDR	f = 22.1 kHz			8.5	
		3.125	ACDR	f = 1.875 MHz			0.10	
		3.125	ACDR	f = 20 MHz			0.10	
General Receive Jitter Tolerance		Rate (Gb/s)	Mode⁽³⁾	Pattern				
Receive deterministic jitter tolerance	T _{DJTOL} ^(2,4)	6.5 ⁽⁵⁾	ACDR	PRBS7			0.65	UI ⁽¹⁾
		5.0 ⁽⁵⁾	ACDR	PRBS7			0.65	
		4.25 ⁽⁵⁾	ACDR	PRBS7			0.65	
		3.125	ACDR	PRBS7			0.60	
		2.5	ACDR	PRBS7			0.55	
		1.25	ACDR	PRBS7			0.50	
		1.25	DCCR	PRBS7			0.50	
		1.25	DCCR	PRBS31			0.40	
Sinusoidal jitter tolerance	T _{SJTOL}	6.5 ⁽⁹⁾	ACDR	PRBS7			0.65	
		5.0 ⁽⁹⁾	ACDR	PRBS7			0.65	
		4.25 ⁽⁹⁾	ACDR	PRBS7			0.65	
		3.125 ⁽⁸⁾	ACDR	PRBS7			0.50	
		2.5 ⁽⁸⁾	ACDR	PRBS7			0.50	
		1.25 ⁽⁸⁾	ACDR	PRBS7			0.50	
		1.25 ⁽⁸⁾	DCCR	PRBS7			0.55	
		1.25 ⁽⁸⁾	DCCR	PRBS31			0.35	
		0.622 ⁽⁸⁾	DCCR	PRBS31			0.55	
RXUSRCLK frequency	T _{RX}	For slower speed grades = MaxDataRate/32					250	MHz
RXUSRCLK2 frequency	T _{RX2}						250	MHz
RXUSRCLK duty cycle	T _{RXDC}				40		60	%
RXUSRCLK2 duty cycle	T _{RX2DC}				40		60	%
Differential input skew	T _{ISKEW}						20	ps
Differential receive input sensitivity ⁽²⁾	V _{EYE}				110			mV
On-chip AC coupling corner frequency								
Signal detect response time	RXSIGDET _{Responsetime}					30		ns
Input capacitance at the Die	C _{DIE}							fF
Excess capacitance at the solder ball	C _{BALL}							fF

Notes:

1. UI = Unit Interval
2. Using receiver equalization setting of 111 (14 dB).
3. ACDR = Analog CDR and DCCR = Digital CDR.
4. Deterministic jitter (DJ) is composed of 75% ISI + 25% high frequency sinusoidal jitter (SJ).
5. Deterministic Jitter (DJ) composed of ISI + 0.10 UI of high frequency SJ + 0.15 UI of RJ.
6. Sum of DJ, random jitter (RJ) of at least 0.55 UI, and sinusoidal jitter as defined by mask in *IEEE Std 802.3ae-2002, Figure 47-5*.
7. SJ in addition to 0.55 UI of DJ +RJ.
8. Jitter frequency = 5 MHz.
9. Jitter frequency = 10 MHz.

Table 26: RocketIO Transmitter Switching Characteristics

Description	Symbol	Conditions		Min	Typ	Max	Units
Serial data rate, -10	F _{GTX}			0.622		3.125	Gb/s
Serial data rate, -11	F _{GTX}			0.622		6.5	Gb/s
		Data	Rate (Gb/s)				
TX Jitter Generation ⁽³⁾	TJ	PRBS7	6.5			0.50	UI ⁽¹⁾
	RJ					0.35	
	DJ					0.30	
	TJ	PRBS7	5.0			0.45	
	RJ					0.30	
	DJ					0.25	
	TJ	PRBS7	4.25			0.40	
	RJ					0.25	
	DJ					0.21	
	TJ	PRBS7	3.125			0.28	
	RJ					0.14	
	DJ					0.14	
	TJ	PRBS7	2.5			0.25	
	RJ					0.18	
	DJ					0.12	
	TJ	PRBS7	1.25			0.12	
	RJ					0.10	
	DJ					0.06	
TJ	PRBS31	0.622			0.08		
RJ					0.06		
DJ					0.04		
TX rise time ⁽²⁾	T _{RTX}	20% – 80%			90		ps
TX fall time ⁽²⁾	T _{FTX}	20% – 80%			90		ps
TXUSRCLK frequency		For slower speed grades = MaxDataRate/32				250	MHz
TXUSRCLK2 frequency						250	MHz
TXUSRCLK duty cycle	T _{TXDC}			40		60	%
TXUSRCLK2 duty cycle	T _{TX2DC}			40		60	%
Differential output skew	T _{ISKEW}				12	20	ps
Electrical idle transition time	TXOOB _{Transition}				15		ns

Notes:

1. UI = Unit Interval.
2. Default attributes, measured at 2.5 Gb/s.
3. Peak-to-Peak values measured relative to 1e-12 Error rate. Default attributes. TX feedback divider (TXPLLNDIVSEL) = 10.

IOB Pad Input/Output/3-State Switching Characteristics

Table 27 summarizes the values of standard-specific data input delay adjustments, output delays terminating at pads (based on standard and 3-state delays).

T_{IOPI} is described as the delay from IOB pad through the input buffer to the I-pin of an IOB pad. The delay varies depending on the capability of the SelectIO input buffer.

T_{IOOP} is described as the delay from the O pin to the IOB pad through the output buffer of an IOB pad. The delay varies depending on the capability of the SelectIO output buffer.

T_{IOTP} is described as the delay from the T pin to the IOB pad through the output buffer of an IOB pad, when 3-state is disabled. The delay varies depending on the SelectIO capability of the output buffer.

Table 28 summarizes the value of T_{IOTPHZ} . T_{IOTPHZ} is described as the delay from the T pin to the IOB pad through the output buffer of an IOB pad, when 3-state is enabled (i.e., a high impedance state).

Table 27: IOB Switching Characteristics^(1,2)

IOSTANDARD Attribute ⁽¹⁾	T_{IOPI}			T_{IOOP}			T_{IOTP}			Units
	Speed Grade			Speed Grade			Speed Grade			
	-12	-11	-10	-12	-11	-10	-12	-11	-10	
LVDS_25	1.00	1.15	1.28	1.61	1.71	1.85	1.61	1.71	1.85	ns
RSDS_25	1.00	1.15	1.28	1.61	1.71	1.85	1.61	1.71	1.85	ns
LVDS25_25	1.01	1.16	1.30	1.65	1.75	1.91	1.65	1.75	1.91	ns
LDT_25	1.00	1.15	1.28	1.58	1.68	1.82	1.58	1.68	1.82	ns
BLVDS_25	1.00	1.15	1.28	1.99	2.15	2.34	1.99	2.15	2.34	ns
ULVDS_25	1.00	1.15	1.28	1.59	1.68	1.83	1.59	1.68	1.83	ns
PCI33_3 (PCI, 33 MHz, 3.3V)	0.76	0.87	0.97	2.52	2.76	3.02	2.52	2.76	3.02	ns
PCI66_3 (PCI, 66 MHz, 3.3V)	0.76	0.87	0.97	2.22	2.46	2.72	2.22	2.46	2.72	ns
PCI-X	0.76	0.87	0.97	2.19	2.21	2.25	2.19	2.21	2.25	ns
GTL	1.28	1.47	1.63	1.75	1.87	2.03	1.75	1.87	2.03	ns
GTLP	1.31	1.51	1.68	1.75	1.87	2.03	1.75	1.87	2.03	ns
HSTL_I	1.28	1.47	1.64	2.00	2.16	2.35	2.00	2.16	2.35	ns
HSTL_II	1.28	1.47	1.64	1.83	1.96	2.13	1.83	1.96	2.13	ns
HSTL_III	1.28	1.47	1.64	1.90	2.04	2.22	1.90	2.04	2.22	ns
HSTL_IV	1.28	1.47	1.64	1.75	1.87	2.03	1.75	1.87	2.03	ns
HSTL_I_18	1.26	1.44	1.60	1.89	2.03	2.21	1.89	2.03	2.21	ns
HSTL_II_18	1.26	1.44	1.60	1.85	1.98	2.16	1.85	1.98	2.16	ns
HSTL_III_18	1.26	1.44	1.60	1.80	1.93	2.09	1.80	1.93	2.09	ns
HSTL_IV_18	1.26	1.44	1.60	1.77	1.89	2.06	1.77	1.89	2.06	ns
SSTL2_I	1.31	1.51	1.68	2.06	2.23	2.43	2.06	2.23	2.43	ns
SSTL2_II	1.31	1.51	1.68	1.85	1.98	2.16	1.85	1.98	2.16	ns
LVTTTL, Slow, 2 mA	0.76	0.87	0.97	5.66	6.37	7.03	5.66	6.37	7.03	ns
LVTTTL, Slow, 4 mA	0.76	0.87	0.97	4.10	4.57	5.04	4.10	4.57	5.04	ns
LVTTTL, Slow, 6 mA	0.76	0.87	0.97	4.00	4.46	4.91	4.00	4.46	4.91	ns
LVTTTL, Slow, 8 mA	0.76	0.87	0.97	4.00	4.46	4.91	4.00	4.46	4.91	ns

Table 27: IOB Switching Characteristics^(1,2) (Continued)

IOSTANDARD Attribute ⁽¹⁾	T _{IOPI}			T _{IOOP}			T _{IOTP}			Units
	Speed Grade			Speed Grade			Speed Grade			
	-12	-11	-10	-12	-11	-10	-12	-11	-10	
LVTTL, Slow, 12 mA	0.76	0.87	0.97	3.26	3.61	3.96	3.26	3.61	3.96	ns
LVTTL, Slow, 16 mA	0.76	0.87	0.97	2.87	3.16	3.46	2.87	3.16	3.46	ns
LVTTL, Slow, 24 mA	0.76	0.87	0.97	2.60	2.85	3.12	2.60	2.85	3.12	ns
LVTTL, Fast, 2 mA	0.76	0.87	0.97	3.96	4.41	4.86	3.96	4.41	4.86	ns
LVTTL, Fast, 4 mA	0.76	0.87	0.97	2.87	3.16	3.46	2.87	3.16	3.46	ns
LVTTL, Fast, 6 mA	0.76	0.87	0.97	2.51	2.74	3.00	2.51	2.74	3.00	ns
LVTTL, Fast, 8 mA	0.76	0.87	0.97	2.34	2.55	2.79	2.34	2.55	2.79	ns
LVTTL, Fast, 12 mA	0.76	0.87	0.97	2.09	2.26	2.47	2.09	2.26	2.47	ns
LVTTL, Fast, 16 mA	0.76	0.87	0.97	2.09	2.26	2.47	2.09	2.26	2.47	ns
LVTTL, Fast, 24 mA	0.76	0.87	0.97	1.88	2.02	2.20	1.88	2.02	2.20	ns
LVC MOS33, Slow, 2 mA	0.76	0.87	0.97	6.98	7.88	8.73	6.98	7.88	8.73	ns
LVC MOS33, Slow, 4 mA	0.76	0.87	0.97	4.92	5.52	6.09	4.92	5.52	6.09	ns
LVC MOS33, Slow, 6 mA	0.76	0.87	0.97	4.07	4.54	5.00	4.07	4.54	5.00	ns
LVC MOS33, Slow, 8 mA	0.76	0.87	0.97	3.25	3.59	3.95	3.25	3.59	3.95	ns
LVC MOS33, Slow, 12 mA	0.76	0.87	0.97	2.83	3.11	3.42	2.83	3.11	3.42	ns
LVC MOS33, Slow, 16 mA	0.76	0.87	0.97	2.11	2.28	2.49	2.11	2.28	2.49	ns
LVC MOS33, Slow, 24 mA	0.76	0.87	0.97	2.11	2.28	2.49	2.11	2.28	2.49	ns
LVC MOS33, Fast, 2 mA	0.76	0.87	0.97	5.98	6.73	7.44	5.98	6.73	7.44	ns
LVC MOS33, Fast, 4 mA	0.76	0.87	0.97	3.55	3.93	4.33	3.55	3.93	4.33	ns
LVC MOS33, Fast, 6 mA	0.76	0.87	0.97	2.93	3.23	3.55	2.93	3.23	3.55	ns
LVC MOS33, Fast, 8 mA	0.76	0.87	0.97	2.09	2.25	2.46	2.09	2.25	2.46	ns
LVC MOS33, Fast, 12 mA	0.76	0.87	0.97	1.93	2.08	2.27	1.93	2.08	2.27	ns
LVC MOS33, Fast, 16 mA	0.76	0.87	0.97	1.79	1.91	2.08	1.79	1.91	2.08	ns
LVC MOS33, Fast, 24 mA	0.76	0.87	0.97	1.79	1.91	2.08	1.79	1.91	2.08	ns
LVC MOS25, Slow, 2 mA	0.69	0.80	0.88	4.77	5.34	5.89	4.77	5.34	5.89	ns
LVC MOS25, Slow, 4 mA	0.69	0.80	0.88	4.09	4.56	5.02	4.09	4.56	5.02	ns
LVC MOS25, Slow, 6 mA	0.69	0.80	0.88	3.53	3.92	4.31	3.53	3.92	4.31	ns
LVC MOS25, Slow, 8 mA	0.69	0.80	0.88	3.53	3.92	4.31	3.53	3.92	4.31	ns
LVC MOS25, Slow, 12 mA	0.69	0.80	0.88	2.90	3.19	3.50	2.90	3.19	3.50	ns
LVC MOS25, Slow, 16 mA	0.69	0.80	0.88	2.75	3.02	3.31	2.75	2.02	3.31	ns
LVC MOS25, Slow, 24 mA	0.69	0.80	0.88	2.33	2.54	2.77	2.33	2.54	2.77	ns
LVC MOS25, Fast, 2 mA	0.69	0.80	0.88	3.20	3.54	3.89	3.20	3.54	3.89	ns
LVC MOS25, Fast, 4 mA	0.69	0.80	0.88	2.66	2.92	3.19	2.66	2.92	3.19	ns
LVC MOS25, Fast, 6 mA	0.69	0.80	0.88	2.36	2.57	2.81	2.36	2.57	2.81	ns
LVC MOS25, Fast, 8 mA	0.69	0.80	0.88	2.13	2.31	2.52	2.13	2.31	2.52	ns
LVC MOS25, Fast, 12 mA	0.69	0.80	0.88	2.06	2.23	2.43	2.06	2.23	2.43	ns

Table 27: IOB Switching Characteristics^(1,2) (Continued)

IOSTANDARD Attribute ⁽¹⁾	T _{IOPI}			T _{IOOP}			T _{IOTP}			Units
	Speed Grade			Speed Grade			Speed Grade			
	-12	-11	-10	-12	-11	-10	-12	-11	-10	
LVC MOS25, Fast, 16 mA	0.69	0.80	0.88	1.89	2.03	2.21	1.89	2.03	2.21	ns
LVC MOS25, Fast, 24 mA	0.69	0.80	0.88	1.83	1.96	2.13	1.83	1.96	2.13	ns
LVC MOS18, Slow, 2 mA	0.97	1.12	1.25	4.77	5.34	5.89	4.77	5.34	5.89	ns
LVC MOS18, Slow, 4 mA	0.97	1.12	1.25	3.56	3.95	4.35	3.56	3.95	4.35	ns
LVC MOS18, Slow, 6 mA	0.97	1.12	1.25	3.29	3.64	4.00	3.29	3.64	4.00	ns
LVC MOS18, Slow, 8 mA	0.97	1.12	1.25	3.10	3.42	3.76	3.10	3.42	3.76	ns
LVC MOS18, Slow, 12 mA	0.97	1.12	1.25	3.09	3.41	3.74	3.09	3.41	3.74	ns
LVC MOS18, Slow, 16 mA	0.97	1.12	1.25	2.94	3.24	3.55	2.94	3.24	3.55	ns
LVC MOS18, Fast, 2 mA	0.97	1.12	1.25	3.20	3.54	3.89	3.20	3.54	3.89	ns
LVC MOS18, Fast, 4 mA	0.97	1.12	1.25	2.52	2.75	3.02	2.52	2.75	3.02	ns
LVC MOS18, Fast, 6 mA	0.97	1.12	1.25	2.29	2.49	2.72	2.29	2.49	2.72	ns
LVC MOS18, Fast, 8 mA	0.97	1.12	1.25	2.13	2.31	2.52	2.13	2.31	2.52	ns
LVC MOS18, Fast, 12 mA	0.97	1.12	1.25	2.01	2.17	2.36	2.01	2.17	2.36	ns
LVC MOS18, Fast, 16 mA	0.97	1.12	1.25	1.94	2.09	2.27	1.94	2.09	2.27	ns
LVC MOS15, Slow, 2 mA	1.05	1.20	1.34	5.33	5.99	6.61	5.33	5.99	6.61	ns
LVC MOS15, Slow, 4 mA	1.05	1.20	1.34	4.21	4.70	4.88	4.21	4.70	4.88	ns
LVC MOS15, Slow, 6 mA	1.05	1.20	1.34	3.49	3.87	4.26	3.49	3.87	4.26	ns
LVC MOS15, Slow, 8 mA	1.05	1.20	1.34	3.49	3.87	4.26	3.49	3.87	4.26	ns
LVC MOS15, Slow, 12 mA	1.05	1.20	1.34	3.11	3.43	3.77	3.11	3.43	3.77	ns
LVC MOS15, Slow, 16 mA	1.05	1.20	1.34	2.92	3.21	3.53	2.92	3.21	3.53	ns
LVC MOS15, Fast, 2 mA	1.05	1.20	1.34	3.42	3.79	4.17	3.42	3.79	4.17	ns
LVC MOS15, Fast, 4 mA	1.05	1.20	1.34	2.76	3.03	3.32	2.76	3.03	3.32	ns
LVC MOS15, Fast, 6 mA	1.05	1.20	1.34	2.46	2.69	2.94	2.46	2.69	2.94	ns
LVC MOS15, Fast, 8 mA	1.05	1.20	1.34	2.28	2.48	2.71	2.28	2.48	2.71	ns
LVC MOS15, Fast, 12 mA	1.05	1.20	1.34	2.12	2.29	2.50	2.12	2.29	2.50	ns
LVC MOS15, Fast, 16 mA	1.05	1.20	1.34	2.06	2.23	2.43	2.06	2.23	2.43	ns
LVDCI_33	0.76	0.87	0.97	2.61	2.86	3.13	2.61	2.86	3.13	ns
LVDCI_25	0.69	0.80	0.88	2.52	2.76	3.02	2.52	2.76	3.02	ns
LVDCI_18	0.97	1.12	1.25	2.47	2.69	2.95	2.47	2.69	2.95	ns
LVDCI_15	1.05	1.20	1.34	2.45	2.68	2.93	2.45	2.68	2.93	ns
LVDCI_DV2_25	0.69	0.80	0.88	1.93	2.08	2.27	1.93	2.08	2.27	ns
LVDCI_DV2_18	0.97	1.12	1.25	1.95	2.09	2.28	1.95	2.09	2.28	ns
LVDCI_DV2_15	1.05	1.20	1.34	2.18	2.36	2.58	2.18	2.36	2.58	ns
GTL_DC I ⁽³⁾	1.18	1.36	1.51	1.75	1.87	2.03	1.75	1.87	2.03	ns
GTLP_DC I ⁽³⁾	0.96	1.11	1.23	1.75	1.87	2.03	1.75	1.87	2.03	ns
HSTL_I_DC I ⁽³⁾	1.28	1.47	1.64	2.00	2.16	2.35	2.00	2.16	2.35	ns

Table 27: IOB Switching Characteristics^(1,2) (Continued)

IOSTANDARD Attribute ⁽¹⁾	T _{IOPI}			T _{IOOP}			T _{IOTP}			Units
	Speed Grade			Speed Grade			Speed Grade			
	-12	-11	-10	-12	-11	-10	-12	-11	-10	
HSTL_II_DCI ⁽³⁾	1.28	1.47	1.64	1.83	1.96	2.13	1.83	1.96	2.13	ns
HSTL_III_DCI ⁽³⁾	1.28	1.47	1.64	1.90	2.04	2.22	1.90	2.04	2.22	ns
HSTL_IV_DCI ⁽³⁾	1.28	1.47	1.64	1.75	1.87	2.03	1.75	1.87	2.03	ns
HSTL_I_DCI_18 ⁽³⁾	1.26	1.44	1.60	1.89	2.03	2.21	1.89	2.03	2.21	ns
HSTL_II_DCI_18 ⁽³⁾	1.26	1.44	1.60	1.85	1.98	2.16	1.85	1.98	2.16	ns
HSTL_III_DCI_18 ⁽³⁾	1.26	1.44	1.60	1.80	1.93	2.09	1.80	1.93	2.09	ns
HSTL_IV_DCI_18 ⁽³⁾	1.26	1.44	1.60	1.77	1.89	2.06	1.77	1.89	2.06	ns
SSTL2_I_DCI ⁽³⁾	1.31	1.51	1.68	2.09	2.25	2.46	2.09	2.25	2.46	ns
SSTL2_II_DCI ⁽³⁾	1.31	1.51	1.68	2.07	2.24	2.45	2.07	2.24	2.45	ns
LVPECL_25	1.38	1.59	1.77	1.52	1.61	1.74	1.52	1.61	1.74	ns
SSTL18_I	1.31	1.51	1.68	2.15	2.33	2.54	2.15	2.33	2.54	ns
SSTL18_II	1.31	1.51	1.68	1.92	2.06	2.24	1.92	2.06	2.24	ns
SSTL18_I_DCI ⁽³⁾	1.31	1.51	1.68	1.97	2.12	2.32	1.97	2.12	2.32	ns
SSTL18_II_DCI ⁽³⁾	1.31	1.51	1.68	1.87	2.00	2.18	1.87	2.00	2.18	ns

Notes:

1. The I/O standard is selected in the Xilinx ISE® software tool using the IOSTANDARD attribute.
2. All I/O timing specifications are measured with V_{CCO} at -5% from nominal.
3. The values of the DCI reference resistors must be within a 20Ω-100Ω range. Refer to [UG070](#), *Virtex-4 FPGA User Guide*, for detailed information.

Table 28: IOB 3-state ON Output Switching Characteristics (T_{IOTPHZ})

Symbol	Description	Speed Grade			Units
		-12	-11	-10	
T _{IOTPHZ}	T input to Pad high-impedance	0.88	1.01	1.12	ns

Ethernet MAC Switching Characteristics

Consult [UG074](#): *Virtex-4 FPGA Embedded Tri-mode Ethernet MAC User Guide* for further information.

Table 29: Maximum Ethernet MAC Performance

Description	Speed Grade			Units
	-12	-11	-10	
Ethernet MAC Maximum Performance	10/100/1000			Mb/s

I/O Standard Adjustment Measurement Methodology

Input Delay Measurements

Table 30 shows the test setup parameters used for measuring input delay.

Table 30: Input Delay Measurement Methodology

Description	I/O Standard Attribute	$V_L^{(1,2)}$	$V_H^{(1,2)}$	$V_{MEAS}^{(1,4,5)}$	$V_{REF}^{(1,3,5)}$
LVTTTL (Low-Voltage Transistor-Transistor Logic)	LVTTTL	0	3.0	1.4	–
LVC MOS (Low-Voltage CMOS), 3.3V	LVC MOS33	0	3.3	1.65	–
LVC MOS, 2.5V	LVC MOS25	0	2.5	1.25	–
LVC MOS, 1.8V	LVC MOS18	0	1.8	0.9	–
LVC MOS, 1.5V	LVC MOS15	0	1.5	0.75	–
PCI (Peripheral Component Interface), 33 MHz, 3.3V	PCI33_3	Per PCI™ Specification			–
PCI, 66 MHz, 3.3V	PCI66_3	Per PCI Specification			–
PCI-X, 133 MHz, 3.3V	PCIX	Per PCI-X™ Specification			–
GTL (Gunning Transceiver Logic)	GTL	$V_{REF} - 0.2$	$V_{REF} + 0.2$	V_{REF}	0.80
GTL Plus	GTLP	$V_{REF} - 0.2$	$V_{REF} + 0.2$	V_{REF}	1.0
HSTL (High-Speed Transceiver Logic), Class I & II	HSTL_I, HSTL_II	$V_{REF} - 0.5$	$V_{REF} + 0.5$	V_{REF}	0.75
HSTL, Class III & IV	HSTL_III, HSTL_IV	$V_{REF} - 0.5$	$V_{REF} + 0.5$	V_{REF}	0.90
HSTL, Class I & II, 1.8V	HSTL_I_18, HSTL_II_18	$V_{REF} - 0.5$	$V_{REF} + 0.5$	V_{REF}	0.90
HSTL, Class III & IV, 1.8V	HSTL_III_18, HSTL_IV_18	$V_{REF} - 0.5$	$V_{REF} + 0.5$	V_{REF}	1.08
SSTL (Stub Terminated Transceiver Logic), Class I & II, 3.3V	SSTL3_I, SSTL3_II	$V_{REF} - 1.00$	$V_{REF} + 1.00$	V_{REF}	1.5
SSTL, Class I & II, 2.5V	SSTL2_I, SSTL2_II	$V_{REF} - 0.75$	$V_{REF} + 0.75$	V_{REF}	1.25
SSTL, Class I & II, 1.8V	SSTL18_I, SSTL18_II	$V_{REF} - 0.5$	$V_{REF} + 0.5$	V_{REF}	0.90
AGP-2X/AGP (Accelerated Graphics Port)	AGP	$V_{REF} - (0.2 \times V_{CCO})$	$V_{REF} + (0.2 \times V_{CCO})$	V_{REF}	AGP Spec
LVDS (Low-Voltage Differential Signaling), 2.5V	LVDS_25	1.2 – 0.125	1.2 + 0.125	1.2	
LVDS EXT (LVDS Extended Mode), 2.5V	LVDS EXT_25	1.2 – 0.125	1.2 + 0.125	1.2	
ULVDS (Ultra LVDS), 2.5V	ULVDS_25	0.6 – 0.125	0.6 + 0.125	0.6	
LDT (HyperTransport), 2.5V	LDT_25	0.6 – 0.125	0.6 + 0.125	0.6	

Notes:

1. Input delay measurement methodology parameters for LVDCI and HSLVDCI are the same as for LVC MOS standards of the same voltage. Parameters for all other DCI standards are the same as for the corresponding non-DCI standards.
2. Input waveform switches between V_L and V_H .
3. Measurements are made at typical, minimum, and maximum V_{REF} values. Reported delays reflect worst case of these measurements. V_{REF} values listed are typical.
4. Input voltage level from which measurement starts.
5. This is an input voltage reference that bears no relation to the V_{REF} / V_{MEAS} parameters found in IBIS models and/or noted in Figure 4.

Output Delay Measurements

Output delays are measured using a Tektronix P6245 TDS500/600 probe (< 1 pF) across approximately 4 inches of FR4 microstrip trace. Standard termination was used for all testing. The propagation delay of the 4 inch trace is characterized separately and subtracted from the final measurement, and is therefore not included in the generalized test setup shown in Figure 4.

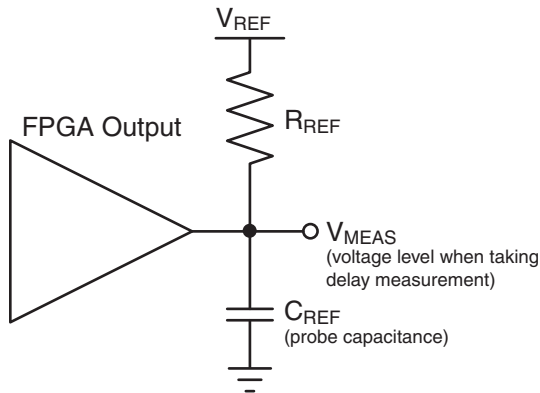

DS302_05_031708

Figure 4: Generalized Test Setup

Measurements and test conditions are reflected in the IBIS models except where the IBIS format precludes it. Parameters V_{REF} , R_{REF} , C_{REF} , and V_{MEAS} fully describe the test conditions for each I/O standard. The most accurate prediction of propagation delay in any given application can be obtained through IBIS simulation, using the following method:

1. Simulate the output driver of choice into the generalized test setup, using values from Table 31.
2. Record the time to V_{MEAS} .
3. Simulate the output driver of choice into the actual PCB trace and load, using the appropriate IBIS model or capacitance value to represent the load.
4. Record the time to V_{MEAS} .
5. Compare the results of steps 2 and 4. The increase or decrease in delay yields the actual worst-case propagation delay (clock-to-input) of the PCB trace.

Table 31: Output Delay Measurement Methodology

Description	I/O Standard Attribute	R_{REF} (Ω)	$C_{REF}^{(1)}$ (pF)	V_{MEAS} (V)	V_{REF} (V)
LVTTTL (Low-Voltage Transistor-Transistor Logic)	LVTTTL (all)	1M	0	1.4	0
LVC MOS (Low-Voltage CMOS), 3.3V	LVC MOS33	1M	0	1.65	0
LVC MOS, 2.5V	LVC MOS25	1M	0	1.25	0
LVC MOS, 1.8V	LVC MOS18	1M	0	0.9	0
LVC MOS, 1.5V	LVC MOS15	1M	0	0.75	0
LVC MOS, 1.2V	LVC MOS12	1M	0	0.75	0
PCI (Peripheral Component Interface), 33 MHz, 3.3V	PCI33_3 (rising edge)	25	10 ⁽²⁾	0.94	0
	PCI33_3 (falling edge)	25	10 ⁽²⁾	2.03	3.3
PCI, 66 MHz, 3.3V	PCI66_3 (rising edge)	25	10 ⁽²⁾	0.94	0
	PCI66_3 (falling edge)	25	10 ⁽²⁾	2.03	3.3
PCI-X, 133 MHz, 3.3V	PCIX (rising edge)	25	10 ⁽³⁾	0.94	
	PCIX (falling edge)	25	10 ⁽³⁾	2.03	3.3
GTL (Gunning Transceiver Logic)	GTL	25	0	0.8	1.2
GTL Plus	GTL P	25	0	1.0	1.5
HSTL (High-Speed Transceiver Logic), Class I	HSTL_I	50	0	V_{REF}	0.75
HSTL, Class II	HSTL_II	25	0	V_{REF}	0.75
HSTL, Class III	HSTL_III	50	0	0.9	1.5
HSTL, Class IV	HSTL_IV	25	0	0.9	1.5
HSTL, Class I, 1.8V	HSTL_I_18	50	0	V_{REF}	0.9
HSTL, Class II, 1.8V	HSTL_II_18	25	0	V_{REF}	0.9
HSTL, Class III, 1.8V	HSTL_III_18	50	0	1.1	1.8

Table 31: Output Delay Measurement Methodology (Continued)

Description	I/O Standard Attribute	R _{REF} (Ω)	C _{REF} ⁽¹⁾ (pF)	V _{MEAS} (V)	V _{REF} (V)
HSTL, Class IV, 1.8V	HSTL_IV_18	25	0	1.1	1.8
SSTL (Stub Series Terminated Logic), Class I, 1.8V	SSTL18_I	50	0	V _{REF}	0.9
SSTL, Class II, 1.8V	SSTL18_II	25	0	V _{REF}	0.9
SSTL, Class I, 2.5V	SSTL2_I	50	0	V _{REF}	1.25
SSTL, Class II, 2.5V	SSTL2_II	25	0	V _{REF}	1.25
LVDS (Low-Voltage Differential Signaling), 2.5V	LVDS_25	50	0	V _{REF}	1.2
LVDS (Low-Voltage Differential Signaling), 2.5V	LVDS_25	50	0	V _{REF}	1.2
LVDS (Low-Voltage Differential Signaling), 2.5V	LVDS_25	50	0	V _{REF}	1.2
BLVDS (Bus LVDS), 2.5V	BLVDS_25	1M	0	1.2	0
LDT (HyperTransport), 2.5V	LDT_25	50	0	V _{REF}	0.6
LVPECL (Low-Voltage Positive Emitter-Coupled Logic), 2.5V	LVPECL_25	1M	0	0.90	0
LVDCI/HSLVDCI (Low-Voltage Digitally Controlled Impedance), 3.3V	LVDCI_33, HSLVDCI_33	1M	0	1.65	0
LVDCI/HSLVDCI, 2.5V	LVDCI_25, HSLVDCI_25	1M	0	1.25	0
LVDCI/HSLVDCI, 1.8V	LVDCI_18, HSLVDCI_18	1M	0	0.9	0
LVDCI/HSLVDCI, 1.5V	LVDCI_15, HSLVDCI_15	1M	0	0.75	0
HSTL (High-Speed Transceiver Logic), Class I & II, with DCI	HSTL_I_DCI, HSTL_II_DCI	50	0	V _{REF}	0.75
HSTL, Class III & IV, with DCI	HSTL_III_DCI, HSTL_IV_DCI	50	0	0.9	1.5
HSTL, Class I & II, 1.8V, with DCI	HSTL_I_DCI_18, HSTL_II_DCI_18	50	0	V _{REF}	0.9
HSTL, Class III & IV, 1.8V, with DCI	HSTL_III_DCI_18, HSTL_IV_DCI_18	50	0	1.1	1.8
SSTL (Stub Series Termi.Logic), Class I & II, 1.8V, with DCI	SSTL18_I_DCI, SSTL18_II_DCI	50	0	V _{REF}	0.9
SSTL, Class I & II, 2.5V, with DCI	SSTL2_I_DCI, SSTL2_II_DCI	50	0	V _{REF}	1.25
GTL (Gunning Transceiver Logic) with DCI	GTL_DCI	50	0	0.8	1.2
GTL Plus with DCI	GTLP_DCI	50	0	1.0	1.5

Notes:

1. C_{REF} is the capacitance of the probe, nominally 0 pF.
2. Per PCI specifications.
3. Per PCI-X specifications.

Input/Output Logic Switching Characteristics

Table 32: ILOGIC Switching Characteristics

Symbol	Description	Speed Grade			Units
		-12	-11	-10	
Setup/Hold					
T_{ICE1CK}/T_{ICKCE1}	CE1 pin Setup/Hold with respect to CLK	0.58 -0.23	0.66 -0.23	0.79 -0.23	ns
T_{ICECK}/T_{ICKCE}	DLYCE pin Setup/Hold with respect to C	0.16 0.11	0.19 0.13	0.23 0.16	ns
T_{IRSTCK}/T_{ICKRST}	DLYRST pin Setup/Hold with respect to C	-0.03 0.37	-0.02 0.45	-0.02 0.54	ns
T_{IINCCK}/T_{ICKINC}	DLYINC pin Setup/Hold with respect to C	0.01 0.36	0.01 0.43	0.01 0.51	ns
T_{ISRCK}/T_{ICKSR}	SR/REV pin Setup/Hold with respect to CLK	1.15 -0.56	1.33 -0.56	1.59 -0.56	ns
T_{IDOCK}/T_{IOCKD}	D pin Setup/Hold with respect to CLK without Delay	0.24 -0.10	0.28 -0.10	0.34 -0.10	ns
T_{IDOCKD}/T_{IOCKDD}	D pin Setup/Hold with respect to CLK (IOBDELAY_TYPE = DEFAULT)	6.64 -5.99	7.63 -5.99	8.84 -5.99	ns
	D pin Setup/Hold with respect to CLK (IOBDELAY_TYPE = FIXED, IOBDELAY_VALUE = 0) ⁽¹⁾	0.81 -0.63	0.87 -0.63	1.09 -0.63	ns
Combinatorial					
T_{IDI}	D pin to O pin propagation delay, no Delay	0.17	0.20	0.24	ns
T_{IDID}	D pin to O pin propagation delay (IOBDELAY_TYPE = DEFAULT)	6.00	6.91	7.96	ns
	D pin to O pin propagation delay (IOBDELAY_TYPE = FIXED, IOBDELAY_VALUE = 0) ⁽¹⁾	0.74	0.79	0.99	ns
Sequential Delays					
T_{IDLO}	D pin to Q1 pin using flip-flop as a latch without Delay	0.50	0.59	0.71	ns
T_{IDL0D}	D pin to Q1 pin using flip-flop as a latch (IOBDELAY_TYPE = DEFAULT)	6.90	7.94	9.21	ns
	D pin to Q1 pin using flip-flop as a latch (IOBDELAY_TYPE = FIXED, IOBDELAY_VALUE = 0) ⁽¹⁾	1.07	1.18	1.45	ns
T_{ICKQ}	CLK to Q outputs	0.53	0.60	0.72	ns
T_{ICE1Q}	CE1 pin to Q1 using flip-flop as a latch, propagation delay	0.90	1.06	1.27	ns
T_{RQ}	SR/REV pin to OQ/TQ out	1.70	2.03	2.44	ns
T_{GSRQ}	Global Set/Reset to Q outputs	1.54	1.73	2.03	ns
Set/Reset					
T_{RPW}	Minimum Pulse Width, SR/REV inputs	0.53	0.59	0.70	ns, Min

Notes:

- Recorded at 0 tap value. Refer to Timing Report for other values.

Table 33: OLOGIC Switching Characteristics

Symbol	Description	Speed Grade			Units
		-12	-11	-10	
Setup/Hold					
T_{ODCK}/T_{OCKD}	D1/D2 pins Setup/Hold with respect to CLK	0.52 -0.22	0.62 -0.22	0.75 -0.22	ns
T_{OOCECK}/T_{OCKOCE}	OCE pin Setup/Hold with respect to CLK	0.53 -0.33	0.64 -0.33	0.77 -0.33	ns
T_{OSRCK}/T_{OCKSR}	SR/REV pin Setup/Hold with respect to CLK	0.99 -0.55	1.18 -0.55	1.42 -0.55	ns
T_{OTCK}/T_{OCKT}	T1/T2 pins Setup/Hold with respect to CLK	0.52 -0.22	0.62 -0.22	0.75 -0.22	ns
T_{OTCECK}/T_{OCKTCE}	TCE pin Setup/Hold with respect to CLK	0.53 -0.33	0.64 -0.33	0.77 -0.33	ns
Combinatorial					
T_{ODQ}	D1 to OQ out	0.56	0.65	0.76	ns
T_{OTQ}	T1 to TQ out	0.56	0.65	0.76	ns
Sequential Delays					
T_{IOSRON}	REV pin to TQ out	1.14	1.37	1.64	ns
T_{OCKQ}	CLK to OQ/TQ out	0.41	0.49	0.59	ns
T_{RQ}	SR/REV pin to OQ/TQ out	1.14	1.37	1.64	ns
T_{GSRQ}	Global Set/Reset to Q outputs	1.54	1.73	2.03	ns
Set/Reset					
T_{RPW}	Minimum Pulse Width, SR/REV inputs	0.53	0.59	0.70	ns, Min

Input Serializer/Deserializer Switching Characteristics

Table 34: ISERDES Switching Characteristics

Symbol	Description	Speed Grade			Units
		-12	-11	-10	
Setup/Hold for Control Lines					
$T_{ISCK_BITS_SLIP} / T_{ISCK_BITS_SLIP}$	BITSLIP pin Setup/Hold with respect to CLKDIV	0.28 -0.20	0.34 -0.16	0.40 -0.13	ns
$T_{ISCK_CE} / T_{ISCK_CE}^{(2)}$	CE pin Setup/Hold with respect to CLK (for CE1)	0.48 -0.37	0.57 -0.30	0.69 -0.25	ns
$T_{ISCK_CE2} / T_{ISCK_CE2}^{(2)}$	CE pin Setup/Hold with respect to CLKDIV (for CE2)	0.11 -0.04	0.14 -0.03	0.16 -0.02	ns
$T_{ISCK_DLYCE} / T_{ISCK_DLYCE}$	DLYCE pin Setup/Hold with respect to CLKDIV	0.16 0.11	0.19 0.13	0.23 0.16	ns
$T_{ISCK_DLYINC} / T_{ISCK_DLYINC}$	DLYINC pin Setup/Hold with respect to CLKDIV	0.01 0.36	0.01 0.43	0.01 0.51	ns
$T_{ISCK_DLYRST} / T_{ISCK_DLYRST}$	DLYRST pin Setup/Hold with respect to CLKDIV	-0.03 0.37	-0.02 0.45	-0.02 0.54	ns
T_{ISCK_SR}	SR pin Setup with respect to CLKDIV	0.64	0.77	0.92	ns
Setup/Hold for Data Lines					
$T_{ISDCK_D} / T_{ISCKD_D}$	D pin Setup/Hold with respect to CLK (IOBDELAY = IBUF or NONE)	0.24 -0.11	0.28 -0.11	0.34 -0.11	ns
	D pin Setup/Hold with respect to CLK (IOBDELAY = IFD or BOTH, IOBDELAY_TYPE = DEFAULT)	6.64 -6.51	7.63 -6.51	8.84 -6.51	ns
	D pin Setup/Hold with respect to CLK ⁽¹⁾ (IOBDELAY = IFD or BOTH, IOBDELAY_TYPE = FIXED, IOBDELAY_VALUE = 0)	0.81 -0.68	0.87 -0.68	1.08 -0.68	ns
$T_{ISDCK_DDR} / T_{ISCKD_DDR}$	D pin Setup/Hold with respect to CLK at DDR mode (IOBDELAY = IBUF or NONE)	0.24 -0.11	0.28 -0.11	0.34 -0.11	ns
	D pin Setup/Hold with respect to CLK at DDR mode (IOBDELAY = IFD or BOTH, IOBDELAY_TYPE = DEFAULT)	6.64 -6.51	7.63 -6.51	8.84 -6.51	ns
	D pin Setup/Hold with respect to CLK at DDR mode ⁽¹⁾ (IOBDELAY = IFD or BOTH, IOBDELAY_TYPE = FIXED, IOBDELAY_VALUE = 0)	0.81 -0.68	0.87 -0.68	1.08 -0.68	ns
Sequential Delays					
T_{ISCKO_Q}	CLKDIV to out at Q pin	0.59	0.71	0.85	ns
Propagation Delays					
$T_{ISDO_DO_IOBDELAY_IFD}$	D input to DO output pin (IOBDELAY = IFD)	0.17	0.20	0.24	ns
$T_{ISDO_DO_IOBDELAY_NONE}$	D input to DO output pin (IOBDELAY = NONE)	0.17	0.20	0.24	ns
$T_{ISDO_DO_IOBDELAY_BOTH}$	D input to DO output pin (IOBDELAY = BOTH, IOBDELAY_TYPE = DEFAULT)	6.00	6.91	7.96	ns
	D input to DO output pin ⁽¹⁾ (IOBDELAY = BOTH, IOBDELAY_TYPE = FIXED, IOBDELAY_VALUE = 0)	0.74	0.79	0.99	ns
$T_{ISDO_DO_IOBDELAY_IBUF}$	D input to DO output pin (IOBDELAY = IBUF, IOBDELAY_TYPE = DEFAULT)	6.00	6.91	7.96	ns
	D input to DO output pin ⁽¹⁾ (IOBDELAY = IBUF, IOBDELAY_TYPE = FIXED, IOBDELAY_VALUE = 0)	0.74	0.79	0.99	ns

Notes:

- Recorded at 0 tap value. Refer to Timing Report for other values.
- T_{ISCK_CE2} and T_{ISCK_CE2} are reported as $T_{ISCK_CE} / T_{ISCK_CE}$ in TRCE report.

Input Delay Switching Characteristics

Table 35: Input Delay Switching Characteristics

Symbol	Description	Speed Grade			Units
		-12	-11	-10	
IDELAYCTRL					
T _{IDELAYCTRLCO_RDY}	Reset to Ready for IDELAYCTRL (Maximum)	3.00	3.00	3.00	µs
F _{IDELAYCTRL_REF}	REFCLK frequency	200	200	200	MHz
IDELAYCTRL_REF_PRECISION ⁽²⁾	REFCLK precision	±10	±10	±10	MHz
T _{IDELAYCTRL_RPW}	Minimum Reset pulse width	50.0	50.0	50.0	ns
IDELAY					
T _{IDELAYRESOLUTION}	IDELAY Chain Delay Resolution	75	75	75	ps
T _{IDELAYTOTAL_ERR}	Cumulative delay at a given tap ⁽³⁾	$\frac{[(\text{tap} - 1) \times 75 + 34]}{\pm 0.07[(\text{tap} - 1) \times 75 + 34]}$			ps
T _{IDELAYPAT_JIT}	Pattern dependent period jitter in delay chain for clock pattern	0	0	0	Note (4)
	Pattern dependent period jitter in delay chain for random data pattern (PRBS 23)	10 ± 2	10 ± 2	10 ± 2	Note (4)
F _{MAX}	C clock maximum frequency	300	250	250	MHz

Notes:

1. Refer to Xilinx Application Note [XAPP707](#) for details on IDELAY timing characteristics.
2. See the "REFCLK - Reference Clock" section (specific to IDELAYCTRL) in the [Virtex-4 FPGA User Guide: Chapter 7, SelectIO Logic Resources](#).
3. This value accounts for tap 0, an anomaly in the tap chain with an average value of 34 ps.
4. Units in ps peak-to-peak per tap.

Output Serializer/Deserializer Switching Characteristics

Table 36: OSERDES Switching Characteristics

Symbol	Description	Speed Grade			Units
		-12	-11	-10	
Setup/Hold					
T_{OSDCK_D}/T_{OSCKD_D}	D input Setup/Hold with respect to CLKDIV	0.35 -0.05	0.42 -0.04	0.50 -0.03	ns
$T_{OSDCK_T}/T_{OSCKD_T}^{(1)}$	T input Setup/Hold with respect to CLK	0.43 -0.16	0.52 -0.16	0.62 -0.16	ns
$T_{OSDCK_T2}/T_{OSCKD_T2}^{(1)}$	T input Setup/Hold with respect to CLKDIV	0.35 -0.05	0.42 -0.04	0.50 -0.03	ns
$T_{OSCK_OCE}/T_{OSCKC_OCE}$	OCE input Setup/Hold with respect to CLK	0.45 0.01	0.53 0.02	0.64 0.03	ns
T_{OSCK_S}	SR (Reset) input Setup with respect to CLKDIV	0.67	0.80	0.96	ns
$T_{OSCK_TCE}/T_{OSCKC_TCE}$	TCE input Setup/Hold with respect to CLK	0.45 0.01	0.53 0.02	0.64 0.03	ns
Sequential Delays					
T_{OSCKO_OQ}	Clock to out from CLK to OQ	0.41	0.49	0.59	ns
T_{OSCKO_TQ}	Clock to out from CLK to TQ	0.41	0.49	0.59	ns
Combinatorial					
T_{OSDO_TTQ}	T input to TQ Out	0.56	0.65	0.76	ns
T_{OSCO_OQ}	Asynchronous Reset to OQ	1.14	1.37	1.64	ns
T_{OSCO_TQ}	Asynchronous Reset to TQ	1.14	1.37	1.64	ns

Notes:

- T_{OSDCK_T2} and T_{OSCKD_T2} are reported as T_{OSDCK_T}/T_{OSCKD_T} in TRCE report.

CLB Switching Characteristics

Table 37: CLB Switching Characteristics

Symbol	Description	Speed Grade				Units
		-12		-11	-10	
		XC4VFX ⁽²⁾	XC4VLX/SX	ALL DEVICES		
Combinatorial Delays						
T _{ILO}	4-input function: F/G inputs to X/Y outputs	0.15	0.15	0.17	0.20	ns, Max
T _{IF5}	5-input function: F/G inputs to F5 output	0.36	0.35	0.40	0.46	ns, Max
T _{IF5X}	5-input function: F/G inputs to X output	0.44	0.43	0.49	0.57	ns, Max
T _{IF6Y}	FXINA or FXINB inputs to YMUX output	0.30	0.30	0.34	0.39	ns, Max
T _{INAFX}	FXINA input to FX output via MUXFX	0.21	0.21	0.23	0.27	ns, Max
T _{INBFX}	FXINB input to FX output via MUXFX	0.21	0.20	0.23	0.26	ns, Max
T _{BXX}	BX input to XMUX output	0.59	0.58	0.65	0.76	ns, Max
T _{BYY}	BY input to YMUX output	0.43	0.43	0.48	0.56	ns, Max
T _{BXCY}	BX input to C _{OUT} output – Getting into carry chain ⁽³⁾	0.60	0.59	0.66	0.78	ns, Max
T _{BYCY}	BY input to C _{OUT} output – Getting into carry chain ⁽³⁾	0.49	0.48	0.54	0.63	ns, Max
T _{BYP}	C _{IN} input to C _{OUT} output – Carry chain delay ⁽³⁾	0.07	0.07	0.08	0.09	ns, Max
T _{OPCYF}	F input to C _{OUT} output – Getting out from carry chain ⁽³⁾	0.45	0.44	0.50	0.58	ns, Max
T _{OPCYG}	G input to C _{OUT} output – Getting out from carry chain ⁽³⁾	0.44	0.43	0.48	0.57	ns, Max
Sequential Delays						
T _{CKO}	FF Clock CLK to XQ/YQ outputs	0.28	0.28	0.31	0.36	ns, Max
T _{CKLO}	Latch Clock CLK to XQ/YQ outputs	0.37	0.36	0.41	0.48	ns, Max
Setup and Hold Times of CLB Flip-Flops Before/After Clock CLK						
T _{DICK} /T _{CKDI}	BX/BY inputs	0.36 -0.09	0.36 -0.09	0.40 -0.09	0.47 -0.09	ns, Min
T _{CECK} /T _{CKCE}	CE input	0.58 -0.16	0.57 -0.16	0.64 -0.16	0.75 -0.16	ns, Min
T _{FXCK} /T _{CKFX}	FXINA/FXINB inputs	0.42 -0.14	0.41 -0.14	0.46 -0.14	0.54 -0.14	ns, Min
T _{SRCK} /T _{CKSR}	SR/BY inputs (synchronous)	1.04 -0.74	1.02 -0.73	1.15 -0.73	1.35 -0.73	ns, Min
T _{CINCK} /T _{CKCIN}	C _{IN} Data Inputs (DI) – Getting out from carry chain ⁽³⁾	0.52 -0.23	0.51 -0.23	0.57 -0.23	0.67 -0.23	ns, Min
Set/Reset						
T _{RPW}	Minimum Pulse Width, SR/BY inputs	0.54	0.53	0.59	0.70	ns, Min
T _{RQ}	Delay from SR/BY inputs to XQ/YQ outputs (asynchronous)	1.05	1.03	1.15	1.35	ns, Max
F _{TOG}	Toggle Frequency (MHz) (for export control)	1181	1205	1205 ⁽⁴⁾	1028	MHz

Notes:

1. A Zero "0" Hold Time listing indicates no hold time or a negative hold time. Negative values cannot be guaranteed "best-case," but if a "0" is listed, there is no positive hold time.
2. The values in this column apply to all XC4VFX -12 parts *except* XC4VFX12 -12. For XC4VFX12 -12 values, use the values in the adjacent 4VLX/SX -12 column.
3. These items are of interest for Carry Chain applications.
4. XC4VFX -11 devices are 1181 MHz.

CLB Distributed RAM Switching Characteristics (SLICEM Only)

Table 38: CLB Distributed RAM Switching Characteristics

Symbol	Description	Speed Grade				Units
		-12		-11	-10	
		XC4VFX ⁽²⁾	XC4VLX/SX	ALL DEVICES		
Sequential Delays						
T _{SHCKO}	Clock CLK to X outputs (WE active) ⁽³⁾	1.61	1.58	1.77	2.08	ns, Max
T _{SHCKOF5}	Clock CLK to F5 output (WE active)	1.53	1.50	1.69	1.98	ns, Max
Setup and Hold Times Before/After Clock CLK						
T _{DS} /T _{DH}	BX/BY data inputs (DI)	1.26 -0.90	1.23 -0.88	1.46 -0.88	1.80 -0.88	ns, Min
T _{AS} /T _{AH}	F/G address inputs	0.88 -0.37	0.86 -0.37	0.97 -0.34	1.13 -0.29	ns, Min
T _{WS} /T _{WH}	WE input (SR)	1.10 -0.48	1.08 -0.47	1.21 -0.47	1.42 -0.47	ns, Min
Clock CLK						
T _{WPH}	Minimum Pulse Width, High	0.53	0.52	0.59	0.69	ns, Min
T _{WPL}	Minimum Pulse Width, Low	0.55	0.54	0.60	0.70	ns, Min
T _{WC}	Minimum clock period to meet address write cycle time	0.76	0.74	0.84	0.98	ns, Min

Notes:

1. A Zero "0" Hold Time listing indicates no hold time or a negative hold time. Negative values cannot be guaranteed "best-case," but if a "0" is listed, there is no positive hold time.
2. The values in this column apply to all XC4VFX -12 parts *except* XC4VFX12 -12. For XC4VFX12 -12 values, use the values in the adjacent XC4VLX/SX -12 column.
3. T_{SHCKO} also represents the CLK to XMUX output. Refer to TRCE report for the CLK to XMUX path.

CLB Shift Register Switching Characteristics (SLICEM Only)

Table 39: CLB Shift Register Switching Characteristics

Symbol	Description	Speed Grade					Units
		-12		-11		-10	
		XC4VFX ⁽²⁾	XC4VLX/SX	XC4VFX ⁽³⁾	XC4VLX/SX	ALL	
Sequential Delays							
T _{REG}	Clock CLK to X/Y outputs	2.12	2.08	2.19	2.19	2.57	ns, Max
T _{REGXB}	Clock CLK to XB output via MC15 LUT output	1.83	1.73	1.90	1.84	2.16	ns, Max
T _{REGYB}	Clock CLK to YB output via MC15 LUT output	1.84	1.74	1.92	1.85	2.17	ns, Max
T _{CKSH}	Clock CLK to Shiftout	1.70	1.60	1.76	1.70	1.99	ns, Max
T _{REGF5}	Clock CLK to F5 output	2.05	2.01	2.11	2.11	2.47	ns, Max
Setup and Hold Times Before/After Clock CLK							
T _{WS} /T _{WH}	WE input (SR)	0.87 -0.76	0.85 -0.76	0.96 -0.70	0.96 -0.70	1.12 -0.62	ns, Min
T _{DS} /T _{DH}	BX/BY data inputs (DI)	1.28 -1.12	1.25 -1.11	1.45 -1.11	1.45 -1.11	1.75 -1.11	ns, Min
Clock CLK							
T _{WPH}	Minimum Pulse Width, High	0.53	0.52	0.59	0.59	0.69	ns, Min
T _{WPL}	Minimum Pulse Width, Low	0.55	0.54	0.60	0.60	0.70	ns, Min

Notes:

1. A Zero "0" Hold Time listing indicates no hold time or a negative hold time. Negative values cannot be guaranteed "best-case," but if a "0" is listed, there is no positive hold time.
2. The values in this column apply to all XC4VFX -12 parts *except* XC4VFX12 -12. For XC4VFX12 -12 values, use the values in the adjacent XC4VLX/SX -12 column.
3. The values in this column apply to *all* XC4VFX -11 parts.

Block RAM and FIFO Switching Characteristics

Table 40: Block RAM Switching Characteristics

Symbol	Description	Speed Grade			Units
		-12	-11	-10	
Sequential Delays					
T_{RCKO_DORA}	Clock CLK to DOUT output (without output register) ⁽²⁾	1.65	1.83	2.10	ns, Max
	Clock CLK to DOUT output with ECC (without output register)	3.00	3.33	3.83	ns, Max
T_{RCKO_DOA}	Clock CLK to DOUT output (with output register) ⁽³⁾	0.72	0.80	0.92	ns, Max
	Clock CLK to DOUT output with ECC (with output register)	2.00	2.20	2.50	ns, Max
Setup and Hold Times Before Clock CLK					
$T_{RCKK_ADDR}/T_{RCKC_ADDR}$	ADDR inputs	0.34 0.26	0.37 0.28	0.43 0.33	ns, Min
T_{RDCK_DI}/T_{RCKD_DI}	DIN inputs ⁽⁴⁾	0.18 0.26	0.20 0.28	0.23 0.33	ns, Min
T_{RCKK_EN}/T_{RCKC_EN}	EN input ⁽⁵⁾	0.41 0.26	0.45 0.28	0.52 0.33	ns, Min
$T_{RCKK_REGCE}/T_{RCKC_REGCE}$	CE input of output register	0.25 0.26	0.27 0.28	0.32 0.33	ns, Min
$T_{RCKK_SSR}/T_{RCKC_SSR}$	RST input	0.25 0.26	0.27 0.28	0.32 0.33	ns, Min
T_{RCKK_WE}/T_{RCKC_WE}	WEN input	0.59 0.26	0.65 0.28	0.75 0.33	ns, Min
Maximum Frequency					
F_{MAX}	Write first and no change mode	500.00	450.45	400.00	MHz
F_{MAX}	Read first mode	500.00	450.45	400.00	MHz
CLK-to-CLK	Read first mode	500.00	450.45	400.00	MHz

Notes:

1. A Zero "0" Hold Time listing indicates no hold time or a negative hold time. Negative values cannot be guaranteed "best-case," but if a "0" is listed, there is no positive hold time.
2. T_{RCKO_DORA} includes T_{RCKO_DOWA} , T_{RCKO_DOPAR} , and T_{RCKO_DOPAW} as well as the B port equivalent timing parameters.
3. T_{RCKO_DOA} includes T_{RCKO_DOPA} as well as the B port equivalent timing parameters.
4. T_{RCKO_DI} includes both A and B inputs as well as the parity inputs of A and B.
5. Xilinx block RAMs do not have asynchronous inputs on an enabled port address. During the time that a port is enabled, its addresses must be stable during the specified set-up time. Do not create an asynchronous input on an enabled port address.

Table 41: FIFO Switching Characteristics

Symbol	Description	Speed Grade			Units
		-12	-11	-10	
Sequential Delays					
T_{FCKO_DO}	Clock CLK to DO output ⁽²⁾	0.72	0.80	0.92	ns, Max
T_{FCKO_FLAGS}	Clock CLK to FIFO flags outputs ⁽³⁾	0.93	1.04	1.19	ns, Max
$T_{FCKO_POINTERS}$	Clock CLK to FIFO pointer outputs ⁽⁴⁾	1.16	1.29	1.48	ns, Max
Setup and Hold Times Before Clock CLK					
$T_{FDCK_DI} / T_{FCKD_DI}$	DI input ⁽⁵⁾	0.18 0.26	0.20 0.28	0.23 0.33	ns, Min
T_{FCK_EN} / T_{FCKC_EN}	Enable inputs ⁽⁶⁾	0.66 0.26	0.73 0.28	0.84 0.33	ns, Min
Reset Delays					
T_{FCO_FLAGS}	Reset RST to FLAGS ⁽⁷⁾	1.32	1.46	1.68	ns, Max
Maximum Frequency					
F_{MAX}	FIFO in all modes	500.00	450.45	400.00	MHz

Notes:

1. A Zero "0" Hold Time listing indicates no hold time or a negative hold time. Negative values cannot be guaranteed "best-case," but if a "0" is listed, there is no positive hold time.
2. T_{FCKO_DO} includes parity output (T_{FCKO_DOP}).
3. T_{FCKO_FLAGS} includes the following parameters: T_{FCKO_AEMPTY} , T_{FCKO_AFULL} , T_{FCKO_EMPTY} , T_{FCKO_FULL} , T_{FCKO_RDERR} , T_{FCKO_WRERR} .
4. $T_{FCKO_POINTERS}$ includes both $T_{FCKO_RDCOUNT}$ and $T_{FCKO_WRCOUNT}$.
5. T_{FDCK_DI} includes parity inputs (T_{FDCK_DIP}).
6. T_{FCK_EN} includes both WRITE and READ enable.
7. T_{FCO_FLAGS} includes the following flags: AEMPTY, AFULL, EMPTY, FULL, RDERR, WRERR, RDCOUNT and WRCOUNT.

XtremeDSP™ Switching Characteristics

Table 42: XtremeDSP Switching Characteristics

Symbol	Description	Speed Grade			Units
		-12	-11	-10	
Setup and Hold of CE Pins					
$T_{DSPCK_{CE}}/T_{DSPCK_{CE}}$	Setup/Hold of all CE inputs of the DSP48 slice	0.39 0.09	0.43 0.10	0.49 0.12	ns
$T_{DSPCK_{RST}}/T_{DSPCK_{RST}}$	Setup/Hold of all RST inputs of the DSP48 slice	0.32 0.09	0.36 0.10	0.40 0.12	ns
Setup and Hold Times of Data					
$T_{DSPCK_{\{AA, BB, CC\}}}/T_{DSPCKD_{\{AA, BB, CC\}}}$	Setup/Hold of {A, B, C} input to {A, B, C} register	0.25 0.23	0.28 0.26	0.32 0.29	ns
$T_{DSPCK_{\{AM, BM\}}}/T_{DSPCKD_{\{AM, BM\}}}$	Setup/Hold of {A, B} input to M register	1.82 0.00	2.03 0.00	2.28 0.00	ns
Sequential Delays					
$T_{DSPCKO_{PP}}$	Clock to out from P register to P output	0.64	0.71	0.79	ns
$T_{DSPCKO_{PM}}$	Clock to out from M register to P output	2.38	2.65	2.98	ns
Combinatorial					
$T_{DSPDO_{\{AP, BP\}L}}$	{A, B} input to P output (LEGACY_MODE = MULT18X18)	3.53	3.92	4.41	ns
Maximum Frequency					
F_{MAX}	From {A, B} register to P register (LEGACY_MODE = MULT18X18)	317.46	285.71	253.94	MHz
	Fully Pipelined	500.00	450.05	400.00	MHz

Configuration Switching Characteristics

Table 43: Configuration Switching Characteristics

Symbol	Description	Speed Grade			Units
		-12	-11	-10	
Power-up Timing Characteristics					
$T_{CONFIG}^{(1,2)}$	Maximum time to configure device after V_{CCINT} has been applied.	10	10	10	minutes
T_{PL}	Program Latency	0.5	0.5	0.5	μ s/frame, Max
T_{POR}	Power-on-Reset	$T_{PL} + 10$	$T_{PL} + 10$	$T_{PL} + 10$	ms, Max
T_{ICCK}	CCLK (output) delay	500	500	500	ns, Min
$T_{PROGRAM}$	Program Pulse Width	300	300	300	ns, Min
Master/Slave Serial Mode Programming Switching					
T_{DCC}/T_{CCD}	DIN Setup/Hold, slave mode	0.5 1.0	0.5 1.0	0.5 1.0	ns, Min
T_{DSCK}/T_{SCKD}	DIN Setup/Hold, master mode	0.5 1.0	0.5 1.0	0.5 1.0	ns, Min
T_{CCO}	DOUT	7.5	7.5	7.5	ns, Max
T_{CCH}	High Time	2.0	2.0	2.0	ns, Min
T_{CCL}	Low Time	2.0	2.0	2.0	ns, Min
F_{CC_SERIAL}	Maximum Frequency, master mode with respect to nominal CCLK.	100	100	100	MHz, Max
$F_{MAX_SLAVE}/F_{MAX_ICAP}$	Maximum Frequency, slave mode external CCLK	100	100	100	MHz, Max
F_{MCCTOL}	Frequency Tolerance, master mode with respect to nominal CCLK.	± 50	± 50	± 50	%
SelectMAP Mode Programming Switching					
T_{SMDCC}/T_{SMCCD}	SelectMAP Data Setup/Hold	2.0 0.0	2.0 0.0	2.0 0.0	ns, Min
T_{SMCSCC}/T_{SMCCCS}	CS_B Setup/Hold	1.0 0.5	1.0 0.5	1.0 0.5	ns, Min
T_{SMCCW}/T_{SMWCC}	RDWR_B Setup/Hold	6.0 1.0	6.0 1.0	6.0 1.0	ns, Min
T_{SMCKBY}	BUSY Propagation Delay	8.0	8.0	8.0	ns, Max
$F_{CC_SELECTMAP}$	Maximum Frequency, master mode with respect to nominal CCLK.	100	100	100	MHz, Max
$F_{MAX_SELECTMAP}$	Maximum Configuration Frequency, slave mode external CCLK	100	100	100	MHz, Max
$F_{MAX_READBACK}$	Maximum Readback Frequency	80	80	80	MHz, Max
F_{MCCTOL}	Frequency Tolerance, master mode with respect to nominal CCLK.	± 50	± 50	± 50	%
T_{SMCO}	SelectMAP Readback Clock-to-Out	8.0	8.0	8.0	ns, Max

Table 43: Configuration Switching Characteristics (Continued)

Symbol	Description	Speed Grade			Units
		-12	-11	-10	
Boundary-Scan Port Timing Specifications					
T_{TAPTCK}	TMS and TDI Setup time before TCK	1.0	1.0	1.0	ns, Min
T_{TCKTAP}	TMS and TDI Hold time after TCK	2.0	2.0	2.0	ns, Min
T_{TCKTDO}	TCK falling edge to TDO output valid	6.0	6.0	6.0	ns, Max
F_{TCK}	Maximum configuration TCK clock frequency	66	66	66	MHz, Max
F_{TCKB}	Maximum Boundary-Scan TCK clock frequency	50	50	50	MHz, Max
Dynamic Reconfiguration Port (DRP) for DCM					
CLKIN_FREQ_DLL_HF_MS_MAX	Maximum frequency for DCLK	500	450	400	MHz, Max
$T_{DMCKC_DADDR}/T_{DMCKC_DADDR}$	DADDR Setup/Hold time	0.54 0.00	0.63 0.00	0.72 0.00	ns, Max
$T_{DMCKC_DI}/T_{DMCKC_DI}$	DI Setup/Hold time	0.54 0.00	0.63 0.00	0.72 0.00	ns, Max
$T_{DMCKC_DEN}/T_{DMCKC_DEN}$	DEN Setup/Hold time	0.58 0.00	0.58 0.00	0.58 0.00	ns, Max
$T_{DMCKC_DWE}/T_{DMCKC_DWE}$	DWE Setup/Hold time	0.58 0.00	0.58 0.00	0.58 0.00	ns, Max
T_{DMCKO_DO}	CLK to out of DO ⁽²⁾	0	0	0	ns, Max
T_{DMCKO_DRDY}	CLK to out of DRDY	0.68	0.80	0.92	ns, Max

Notes:

- T_{BCCCK_CE} and T_{BCKC_CE} must be satisfied to assure glitch-free operation of the global clock when switching between clocks. These parameters do not apply to the BUFGMUX_VIRTEX4 primitive that assures glitch-free operation. The other global clock setup and hold times are optional; only needing to be satisfied if device operation requires simulation matches on a cycle-for-cycle basis when switching between clocks.
- DO holds until the next DRP operation.

Clock Buffers and Networks

Table 44: Global Clock Switching Characteristics (Including BUFGCTRL)

Symbol	Description	Speed Grade			Units
		-12	-11	-10	
$T_{BCCCK_CE} / T_{BCCCK_CE}^{(1)}$	CE pins Setup/Hold	0.27 0.00	0.31 0.00	0.35 0.00	ns
$T_{BCCCK_S} / T_{BCCCK_S}^{(1)}$	S pins Setup/Hold	0.27 0.00	0.31 0.00	0.35 0.00	ns
T_{BCCCK_O}	BUFGCTRL delay	0.70	0.77	0.90	ns
Maximum Frequency					
F_{MAX}	Global clock tree	500	450	400	MHz

Notes:

- T_{BCCCK_CE} and $T_{BCCCK_CE}^{(1)}$ must be satisfied to assure glitch-free operation of the global clock when switching between clocks. These parameters do not apply to the BUFGMUX_VIRTEX4 primitive that assures glitch-free operation. The other global clock setup and hold times are optional; only needing to be satisfied if device operation requires simulation matches on a cycle-for-cycle basis when switching between clocks.

DCM and PMCD Switching Characteristics

Table 45: Operating Frequency Ranges for DCM in Maximum Speed (MS) Mode

Symbol	Description	Speed Grade			Units
		-12	-11	-10	
Outputs Clocks (Low Frequency Mode)					
CLKOUT_FREQ_1X_LF_MS_MIN	CLK0, CLK90, CLK180, CLK270	32	32	32	MHz
CLKOUT_FREQ_1X_LF_MS_MAX		150	150	150	MHz
CLKOUT_FREQ_2X_LF_MS_MIN	CLK2X, CLK2X180	64	64	64	MHz
CLKOUT_FREQ_2X_LF_MS_MAX		300	300	300	MHz
CLKOUT_FREQ_DV_LF_MS_MIN	CLKDV	2	2	2	MHz
CLKOUT_FREQ_DV_LF_MS_MAX		100	100	100	MHz
CLKOUT_FREQ_FX_LF_MS_MIN	CLKFX, CLKFX180	32	32	32	MHz
CLKOUT_FREQ_FX_LF_MS_MAX		210	210	210	MHz
Input Clocks (Low Frequency Mode)					
CLKIN_FREQ_DLL_LF_MS_MIN	CLKIN (using DLL outputs) ^(1,3,4,5,6)	32	32	32	MHz
CLKIN_FREQ_DLL_LF_MS_MAX		150	150	150	MHz
CLKIN_FREQ_FX_LF_MS_MIN	CLKIN (using DFS outputs only) ^(2,3,4)	1	1	1	MHz
CLKIN_FREQ_FX_LF_MS_MAX		210	210	210	MHz
PSCLK_FREQ_LF_MS_MIN	PSCLK	1	1	1	KHz
PSCLK_FREQ_LF_MS_MAX		500	450	400	MHz
Outputs Clocks (High Frequency Mode)					
CLKOUT_FREQ_1X_HF_MS_MIN	CLK0, CLK90, CLK180, CLK270	150	150	150	MHz
CLKOUT_FREQ_1X_HF_MS_MAX		500	450	400	MHz
CLKOUT_FREQ_2X_HF_MS_MIN	CLK2X, CLK2X180	300	300	300	MHz
CLKOUT_FREQ_2X_HF_MS_MAX		500	450	400	MHz
CLKOUT_FREQ_DV_HF_MS_MIN	CLKDV	9.4	9.4	9.4	MHz
CLKOUT_FREQ_DV_HF_MS_MAX		333	300	267	MHz

Table 45: Operating Frequency Ranges for DCM in Maximum Speed (MS) Mode (Continued)

Symbol	Description	Speed Grade			Units
		-12	-11	-10	
CLKOUT_FREQ_FX_HF_MS_MIN	CLKFX, CLKFX180	210	210	210	MHz
CLKOUT_FREQ_FX_HF_MS_MAX		350	315	300	MHz
Input Clocks (High Frequency Mode)					
CLKIN_FREQ_DLL_HF_MS_MIN ⁽⁶⁾	CLKIN (using DLL outputs only) ^(1,3,4,5)	150	150	150	MHz
CLKIN_FREQ_DLL_HF_MS_MAX		500	450	400	MHz
CLKIN_FREQ_FX_HF_MS_MIN	CLKIN (using DFS outputs) ^(2,3,4)	50	50	50	MHz
CLKIN_FREQ_FX_HF_MS_MAX ⁽⁶⁾		350	315	300	MHz
PSCLK_FREQ_HF_MS_MIN	PSCLK	1	1	1	KHz
PSCLK_FREQ_HF_MS_MAX		500	450	400	MHz

Notes:

1. DLL outputs are used in these instances to describe the outputs: CLK0, CLK90, CLK180, CLK270, CLK2X, CLK2X180, and CLKDV.
2. DFS outputs are used in these instances to describe the outputs: CLKFX and CLKFX180.
3. When using the DCMs CLKIN_DIVIDE_BY_2 attribute these values should be doubled.
4. When using a CLKIN frequency > 400 MHz and the DCMs CLKIN_DIVIDE_BY_2 attribute, the CLKIN duty cycle must be within ±5% (45/55 to 55/45).
5. The DCM must be reset if the clock input clock stops for more than 100 ms.
6. These values also apply when using both DLL and DFS outputs.

Table 46: Operating Frequency Ranges for DCM in Maximum Range (MR) Mode

Symbol	Description	Speed Grade			Units
		-12	-11	-10	
Outputs Clocks (Low Frequency Mode)					
CLKOUT_FREQ_1X_LF_MR_MIN	CLK0, CLK90, CLK180, CLK270	19	19	19	MHz
CLKOUT_FREQ_1X_LF_MR_MAX		40	36	32	MHz
CLKOUT_FREQ_2X_LF_MR_MIN	CLK2X, CLK2X180	38	38	38	MHz
CLKOUT_FREQ_2X_LF_MR_MAX		80	72	64	MHz
CLKOUT_FREQ_DV_LF_MR_MIN	CLKDV	1.2	1.2	1.2	MHz
CLKOUT_FREQ_DV_LF_MR_MAX		26.7	24	21.3	MHz
CLKOUT_FREQ_FX_LF_MR_MIN	CLKFX, CLKFX180	19	19	19	MHz
CLKOUT_FREQ_FX_LF_MR_MAX		40	36	32	MHz
Input Clocks (Low Frequency Mode)					
CLKIN_FREQ_DLL_LF_MR_MIN	CLKIN (using DLL outputs) ^(1,3,4,5,6)	19	19	19	MHz
CLKIN_FREQ_DLL_LF_MR_MAX		40	36	32	MHz
CLKIN_FREQ_FX_LF_MR_MIN	CLKIN (using DFS outputs only) ^(2,3,4)	1	1	1	MHz
CLKIN_FREQ_FX_LF_MR_MAX		35	32	28	MHz
PSCLK_FREQ_LF_MR_MIN	PSCLK	1	1	1	KHz
PSCLK_FREQ_LF_MR_MAX		262.50	236.30	210.00	MHz

Notes:

1. DLL Outputs are used in these instances to describe the outputs: CLK0, CLK90, CLK180, CLK270, CLK2X, CLK2X180, and CLKDV.
2. DFS Outputs are used in these instances to describe the outputs: CLKFX and CLKFX180.
3. When using the DCMs CLKIN_DIVIDE_BY_2 attribute these values should be doubled.
4. When using a CLKIN frequency > 400 MHz and the DCMs CLKIN_DIVIDE_BY_2 attribute, the CLKIN duty cycle must be within ±5% (45/55 to 55/45).
5. The DCM must be reset if the clock input clock stops for more than 100 ms.
6. These values also apply when using both DLL and DFS outputs.

Table 47: Input Clock Tolerances

Symbol	Description	Frequency Range		Value	Units
Duty Cycle Input Tolerance (in %)					
CLKIN_PSCLK_PULSE_RANGE_1	PSCLK only	< 1 MHz		25 - 75	%
CLKIN_PSCLK_PULSE_RANGE_1_50	PSCLK and CLKIN	1 – 50 MHz ⁽¹⁾		25 - 75	%
CLKIN_PSCLK_PULSE_RANGE_50_100		50 – 100 MHz ⁽¹⁾		30 - 70	%
CLKIN_PSCLK_PULSE_RANGE_100_200		100 – 200 MHz ⁽¹⁾		40 - 60	%
CLKIN_PSCLK_PULSE_RANGE_200_400		200 – 400 MHz ⁽¹⁾		45 - 55	%
CLKIN_PSCLK_PULSE_RANGE_400		> 400 MHz		45 - 55	%
		Speed Grade			
		-12	-11	-10	
Input Clock Cycle-Cycle Jitter (Low Frequency Mode)					
CLKIN_CYC_JITT_DLL_LF	CLKIN (using DLL outputs) ^(2,5,6)	±300	±300	±345	ps
CLKIN_CYC_JITT_FX_LF	CLKIN (using DFS outputs) ⁽³⁾	±300	±300	±345	ps
Input Clock Cycle-Cycle Jitter (High Frequency Mode)					
CLKIN_CYC_JITT_DLL_HF	CLKIN (using DLL outputs) ^(2,5,6)	±150	±150	±173	ps
CLKIN_CYC_JITT_FX_HF	CLKIN (using DFS outputs) ⁽³⁾	±150	±150	±173	ps
Input Clock Period Jitter (Low Frequency Mode)					
CLKIN_PER_JITT_DLL_LF	CLKIN (using DLL outputs) ^(2,5,6)	±1.0	±1.0	±1.15	ns
CLKIN_PER_JITT_FX_LF	CLKIN (using DFS outputs) ⁽³⁾	±1.0	±1.0	±1.15	ns
Input Clock Period Jitter (High Frequency Mode)					
CLKIN_PER_JITT_DLL_HF	CLKIN (using DLL outputs) ^(2,5,6)	±1.0	±1.0	±1.15	ns
CLKIN_PER_JITT_FX_HF	CLKIN (using DFS outputs) ⁽³⁾	±1.0	±1.0	±1.15	ns
Feedback Clock Path Delay Variation					
CLKFB_DELAY_VAR_EXT	CLKFB off-chip feedback	±1.0	±1.0	±1.15	ns

Notes:

1. For boundary frequencies, use the more restrictive specifications.
2. DLL Outputs are used in these instances to describe the outputs: CLK0, CLK90, CLK180, CLK270, CLK2X, CLK2X180, and CLKDV.
3. DFS Outputs are used in these instances to describe the outputs: CLKFX and CLKFX180.
4. If both DLL and DFS outputs are used, follow the more restrictive specifications.
5. The DCM must be reset if the clock input clock stops for more than 100 ms.
6. These values also apply when using both DLL and DFS outputs.

Output Clock Jitter

Table 48: Output Clock Jitter

Description	Symbol	Constraints	Speed Grade			Units
			-12	-11	-10	
Clock Synthesis Period Jitter						
CLK0	CLKOUT_PER_JITT_0		±100	±100	±100	ps
CLK90	CLKOUT_PER_JITT_90		±150	±150	±150	ps
CLK180	CLKOUT_PER_JITT_180		±150	±150	±150	ps
CLK270	CLKOUT_PER_JITT_270		±150	±150	±150	ps
CLK2X, CLK2X180	CLKOUT_PER_JITT_2X		±200	±200	±200	ps
CLKDV (integer division)	CLKOUT_PER_JITT_DV1		±150	±150	±150	ps
CLKDV (non-integer division)	CLKOUT_PER_JITT_DV2		±300	±300	±300	ps
CLKFX, CLKFX180	CLKOUT_PER_JITT_FX		Note (2)	Note (2)	Note (2)	ps

Notes:

1. PMCD outputs are not included in this table because they do not introduce jitter.
2. Values for this parameter are available from the architecture wizard.

Output Clock Phase Alignment

Table 49: Output Clock Phase Alignment

Description	Symbol	Constraints	Speed Grade			Units
			-12	-11	-10	
Phase Offset Between CLKIN and CLKFB						
CLKIN/CLKFB	CLKIN_CLKFB_PHASE		±120	±120	±120	ps
Phase Offset Between Any DCM Outputs						
All CLK outputs	CLKOUT_PHASE		±140	±140	±140	ps
Duty Cycle Precision						
DLL outputs ⁽¹⁾	CLKOUT_DUTY_CYCLE_DLL ^(3,4)		±150	±150	±150	ps
DFS outputs ⁽²⁾	CLKOUT_DUTY_CYCLE_FX ⁽⁴⁾		±200	±200	±200	ps

Notes:

1. DLL Outputs are used in these instances to describe the outputs: CLK0, CLK90, CLK180, CLK270, CLK2X, CLK2X180, and CLKDV.
2. DFS Outputs are used in these instances to describe the outputs: CLKFX and CLKFX180.
3. CLKOUT_DUTY_CYCLE_DLL applies to the 1X clock outputs (CLK0, CLK90, CLK180, and CLK270) only if DUTY_CYCLE_CORRECTION=TRUE.
4. The measured value includes the duty cycle distortion of the global clock tree.

Table 50: Miscellaneous Timing Parameters

Symbol	Description	Speed Grade			Units
		-12	-11	-10	
Time Required to Achieve LOCK					
T_LOCK_DLL_240	DLL output – Frequency range > 240 MHz ⁽²⁾	20	20	20	µs
T_LOCK_DLL_120_240	DLL output – Frequency range 120 - 240 MHz ^(1,2)	63	63	63	µs
T_LOCK_DLL_60_120	DLL output – Frequency range 60 - 120 MHz ^(1,2)	225	225	225	µs
T_LOCK_DLL_50_60	DLL output – Frequency range 50 - 60 MHz ^(1,2)	325	325	325	µs
T_LOCK_DLL_40_50	DLL output – Frequency range 40 - 50 MHz ^(1,2)	500	500	500	µs
T_LOCK_DLL_30_40	DLL output – Frequency range 30 - 40 MHz ^(1,2)	900	900	900	µs
T_LOCK_DLL_24_30	DLL output – Frequency range 24 - 30 MHz ^(1,2)	1250	1250	1250	µs
T_LOCK_DLL_30	DLL output – Frequency range < 30 MHz ⁽²⁾	1250	1250	1250	µs
T_LOCK_FX_MAX	DFS outputs ⁽³⁾	10	10	10	ms
T_LOCK_DLL_FINE_SHIFT	Multiplication factor for DLL lock time with Fine Shift	2	2	2	
Fine Phase Shifting					
FINE_SHIFT_RANGE_MS	Absolute shifting range in maximum speed mode	7	7	7	ns
FINE_SHIFT_RANGE_MR	Absolute shifting range in maximum range mode	10	10	10	ns
Delay Lines					
DCM_TAP_MS_MIN	Tap delay resolution (Min) in maximum speed mode	5	5	5	ps
DCM_TAP_MS_MAX	Tap delay resolution (Max) in maximum speed mode	40	40	40	ps
DCM_TAP_MR_MIN	Tap delay resolution (Min) in maximum range mode	10	10	10	ps
DCM_TAP_MR_MAX	Tap delay resolution (Max) in maximum range mode	60	60	60	ps
Input Signal Requirements					
DCM_RESET ⁽⁴⁾	Minimum duration that RST must be held asserted	200	200	200	ms
	Maximum duration that RST can be held asserted ⁽⁵⁾	10	10	10	sec
DCM_INPUT_CLOCK_STOP	Maximum duration that CLKIN and CLKFB can be stopped ^(6,7)	100	100	100	ms

Notes:

1. For boundary frequencies, choose the higher delay.
2. DLL Outputs are used in these instances to describe the outputs: CLK0, CLK90, CLK180, CLK270, CLK2X, CLK2X180, and CLKDV.
3. DFS Outputs are used in these instances to describe the outputs: CLKFX and CLKFX180.
4. CLKIN must be present and stable during the DCM_RESET.
5. This only applies to production step 1 LX and SX devices. For these devices, use the design solutions described in Answer Record 21127 for support of longer reset durations. Production step 2 LX and SX devices and all production FX devices do not have this requirement.
6. For production step 1 LX and SX devices, use the design solutions described in Answer Record 21127 for support of longer durations of stopped clocks. For production step 2 LX and SX devices and all production FX devices, the ISE software automatically inserts a small macro to support longer durations of stopped clocks.
7. For all stepping levels, once the input clock is toggling again and stable after being stopped, DCM must be reset.

Table 51: Frequency Synthesis

Attribute	Min	Max
CLKFX_MULTIPLY	2	32
CLKFX_DIVIDE	1	32

Table 52: DCM Switching Characteristics

Symbol	Description	Speed Grade			Units
		-12	-11	-10	
$T_{DMCKC_PSEN}/T_{DMCKC_PSEN}$	PSEN Setup/Hold	0.93 0.00	0.93 0.00	1.07 0.00	ns
$T_{DMCKC_PSINCDEC}/T_{DMCKC_PSINCDEC}$	PSINCDEC Setup/Hold	0.93 0.00	0.93 0.00	1.07 0.00	ns
T_{DMCKO_PSDONE}	Clock to out of PSDONE	0.60	0.60	0.69	ns

Table 53: PMCD Switching Characteristic

Symbol	Description	Speed Grade			Units
		-12	-11	-10	
$T_{PMCCCK_REL}/T_{PMCCCK_REL}$	REL Setup/Hold for all outputs	0.60 0.00	0.60 0.00	0.60 0.00	ns
$T_{PMCCO_CLK\{A1,B,C,D\}}$	RST assertion to clock output deassertion	4.00	4.00	4.50	ns
$T_{PMCCO_CLK\{A1,B,C,D\}}$	Max clock propagation delay of PMCD for all outputs	4.60	4.60	5.20	ns
PMCD_CLK_SKEW	Max phase between all outputs assuming all inputs	±150	±150	±150	ps
CLKIN_FREQ_PMCD_CLKA_MAX ⁽¹⁾	Max input/output frequency	500	450	400	MHz
CLKIN_PSCLK_PULSE_RANGE	Max duty cycle input tolerance (same as DCM)	Note (2)			
PMCD_REL_HIGH_PULSE_MIN	Min pulse width for REL	1.11	1.11	1.25	ns
PMCD_RST_HIGH_PULSE_MIN	Min pulse width for RST	1.11	1.11	1.25	ns

Notes:

- There is no minimum frequency for PMCD.
- Refer to [Table 47](#) parameter: CLKIN_PSCLK_PULSE_RANGE.

System-Synchronous Switching Characteristics

Virtex-4 FPGA Pin-to-Pin Output Parameter Guidelines

All devices are 100% functionally tested. The representative values for typical pin locations and normal clock loading are listed in [Table 54](#). Values are expressed in nanoseconds unless otherwise noted.

Table 54: Global Clock Input to Output Delay for LVC MOS25 Standard, 12 mA, Fast Slew Rate, with DCM

Symbol	Description	Device	Speed Grade			Units
			-12	-11	-10	
LVC MOS25 Global Clock Input to Output Delay using Output Flip-Flop, 12mA, Fast Slew Rate, <i>with</i> DCM.						
T _{ICKOFFDCM}	Global Clock and OFF with DCM	XC4VLX15	2.43	2.81	3.25	ns
		XC4VLX25	2.60	2.95	3.36	ns
		XC4VLX40	2.54	2.91	3.32	ns
		XC4VLX60	2.69	3.05	3.45	ns
		XC4VLX80	2.88	3.27	3.72	ns
		XC4VLX100	2.94	3.33	3.79	ns
		XC4VLX160	2.94	3.35	3.82	ns
		XC4VLX200	N/A	3.51	4.02	ns
		XC4VSX25	2.65	2.99	3.39	ns
		XC4VSX35	2.81	3.18	3.60	ns
		XC4VSX55	2.83	3.20	3.62	ns
		XC4VFX12	2.43	2.78	3.18	ns
		XC4VFX20	2.54	2.88	3.26	ns
		XC4VFX40	2.87	3.25	3.67	ns
		XC4VFX60	2.92	3.31	3.77	ns
		XC4VFX100	3.16	3.58	4.06	ns
XC4VFX140	N/A	3.79	4.30	ns		

Notes:

1. Listed above are representative values where one global clock input drives one vertical clock line in each accessible column, and where all accessible IOB and CLB flip-flops are clocked by the global clock net.
2. DCM output jitter is already included in the timing calculation.

Table 55: Global Clock Input to Output Delay for LVC MOS25 Standard, 12 mA, Fast Slew Rate, without DCM

Symbol	Description	Device	Speed Grade			Units
			-12	-11	-10	
LVC MOS25 Global Clock Input to Output Delay using Output Flip-Flop, 12 mA, Fast Slew Rate, <i>without</i> DCM.						
T _{ICKOF}	Global Clock and OFF without DCM	XC4VLX15	6.42	7.22	8.14	ns
		XC4VLX25	6.50	7.32	8.25	ns
		XC4VLX40	6.70	7.54	8.50	ns
		XC4VLX60	6.86	7.72	8.70	ns
		XC4VLX80	6.98	7.85	8.85	ns
		XC4VLX100	7.23	8.15	9.18	ns
		XC4VLX160	7.46	8.40	9.46	ns
		XC4VLX200	N/A	8.79	9.88	ns
		XC4VSX25	6.69	7.52	8.47	ns
		XC4VSX35	6.75	7.59	8.56	ns
		XC4VSX55	7.10	7.99	9.00	ns
		XC4VFX12	6.41	7.21	8.13	ns
		XC4VFX20	6.60	7.42	8.37	ns
		XC4VFX40	6.97	7.84	8.83	ns
		XC4VFX60	6.98	7.86	8.85	ns
		XC4VFX100	7.46	8.40	9.45	ns
XC4VFX140	N/A	8.80	9.90	ns		

Notes:

- Listed above are representative values where one global clock input drives one vertical clock line in each accessible column, and where all accessible IOB and CLB flip-flops are clocked by the global clock net.

Virtex-4 FPGA Pin-to-Pin Input Parameter Guidelines

All devices are 100% functionally tested. The representative values for typical pin locations and normal clock loading are listed in Table 56. Values are expressed in nanoseconds unless otherwise noted.

Table 56: Global Clock Setup and Hold for LVCMOS25 Standard, with DCM

Symbol	Description	Device	Speed Grade			Units
			-12	-11	-10	
Input Setup and Hold Time Relative to Global Clock Input Signal for LVCMOS25 Standard. ⁽¹⁾						
T _{PSDCM} /T _{PHDCM}	No Delay Global Clock and IFF ⁽²⁾ with DCM	XC4VLX15	1.35 -0.72	1.52 -0.67	1.54 -0.62	ns
		XC4VLX25	1.28 -0.58	1.50 -0.57	1.58 -0.55	ns
		XC4VLX40	1.25 -0.55	1.44 -0.50	1.50 -0.46	ns
		XC4VLX60	1.25 -0.43	1.47 -0.40	1.55 -0.36	ns
		XC4VLX80	1.22 -0.26	1.42 -0.21	1.49 -0.15	ns
		XC4VLX100	1.27 -0.20	1.48 -0.14	1.56 -0.08	ns
		XC4VLX160	1.54 -0.20	1.79 -0.13	1.89 -0.05	ns
		XC4VLX200	N/A	1.90 0.03	2.00 0.15	ns
		XC4VSX25	1.25 -0.50	1.47 -0.48	1.55 -0.48	ns
		XC4VSX35	1.21 -0.41	1.43 -0.38	1.50 -0.34	ns
		XC4VSX55	1.25 -0.23	1.47 -0.18	1.55 -0.13	ns
		XC4VFX12	1.35 -0.71	1.55 -0.69	1.61 -0.69	ns
		XC4VFX20	1.25 -0.52	1.48 -0.51	1.56 -0.51	ns
		XC4VFX40	1.23 -0.18	1.45 -0.13	1.52 -0.08	ns
		XC4VFX60	1.17 -0.06	1.37 0.01	1.44 0.09	ns
		XC4VFX100	1.21 0.11	1.42 0.20	1.49 0.31	ns
XC4VFX140	N/A	1.68 0.21	1.76 0.31	ns		

Notes:

1. Setup time is measured relative to the Global Clock input signal with the fastest route and the lightest load. Hold time is measured relative to the Global Clock input signal with the slowest route and heaviest load.
2. These measurements include:
CLK0 DCM jitter
IFF = Input Flip-Flop or Latch
3. Use IBIS to determine any duty-cycle distortion incurred using various standards.

Table 57: Global Clock Setup and Hold for LVCMOS25 Standard, with DCM in Source-Synchronous Mode

Symbol	Description	Device	Speed Grade			Units
			-12	-11	-10	
Example Data Input Setup and Hold Times Relative to a Forwarded Clock Input Pin, ⁽¹⁾ Using DCM and Global Clock Buffer. For situations where clock and data inputs conform to different standards, adjust the setup and hold values accordingly using the values shown in IOB Switching Characteristics^(1,2) , page 19.						
T_{PSDCM_0} / T_{PHDCM_0}	No Delay Global Clock and IFF ⁽²⁾ with DCM in Source-Synchronous Mode	XC4VLX15	-0.33 0.73	-0.33 0.88	-0.33 1.03	ns
		XC4VLX25	-0.29 0.86	-0.29 0.97	-0.29 1.09	ns
		XC4VLX40	-0.37 0.90	-0.37 1.04	-0.37 1.19	ns
		XC4VLX60	-0.32 1.02	-0.32 1.15	-0.32 1.29	ns
		XC4VLX80	-0.38 1.18	-0.38 1.34	-0.38 1.50	ns
		XC4VLX100	-0.31 1.24	-0.31 1.41	-0.31 1.57	ns
		XC4VLX160	-0.31 1.50	-0.31 1.69	-0.31 1.89	ns
		XC4VLX200	N/A	-0.31 1.97	-0.31 2.19	ns
		XC4VSX25	-0.32 0.95	-0.32 1.07	-0.32 1.17	ns
		XC4VSX35	-0.37 1.04	-0.37 1.17	-0.37 1.31	ns
		XC4VSX55	-0.32 1.22	-0.32 1.36	-0.32 1.52	ns
		XC4VFX12	-0.26 0.73	-0.26 0.86	-0.26 0.96	ns
		XC4VFX20	-0.31 0.92	-0.31 1.03	-0.31 1.14	ns
		XC4VFX40	-0.35 1.26	-0.35 1.41	-0.35 1.56	ns
		XC4VFX60	-0.43 1.39	-0.43 1.56	-0.43 1.74	ns
		XC4VFX100	-0.38 1.55	-0.38 1.75	-0.38 1.96	ns
XC4VFX140	N/A	-0.44 2.03	-0.44 2.25	ns		

Notes:

1. The timing values were measured using the fine-phase adjustment feature of the DCM. These measurements include CLK0 DCM jitter. Package skew is not included in these measurements.
2. IFF = Input Flip-Flop

Table 58: Global Clock Setup and Hold for LVC MOS25 Standard, without DCM

Symbol	Description	Device	Speed Grade			Units
			-12	-11	-10	
Input Setup and Hold Time Relative to Global Clock Input Signal for LVC MOS25 Standard. ⁽¹⁾						
T _{PSFD} /T _{PHFD}	Full Delay Global Clock and IFF ⁽²⁾ without DCM	XC4VLX15	1.82 0.11	2.33 0.19	2.74 0.39	ns
		XC4VLX25	1.79 0.20	2.30 0.29	2.70 0.50	ns
		XC4VLX40	2.06 0.13	2.61 0.22	3.06 0.44	ns
		XC4VLX60	2.39 0.04	2.99 0.12	3.50 0.34	ns
		XC4VLX80	2.36 0.16	2.96 0.26	3.47 0.49	ns
		XC4VLX100	4.85 -0.09	5.83 -0.09	6.76 -0.01	ns
		XC4VLX160	2.56 0.46	3.21 0.59	3.76 0.88	ns
		XC4VLX200	N/A	3.57 0.64	4.17 0.95	ns
		XC4VSX25	2.12 0.14	2.68 0.23	3.14 0.44	ns
		XC4VSX35	2.10 0.21	2.66 0.30	3.12 0.52	ns
		XC4VSX55	1.99 0.57	2.53 0.71	2.97 0.98	ns
		XC4VFX12	1.82 0.12	2.33 0.20	2.73 0.39	ns
		XC4VFX20	1.75 0.38	2.26 0.49	2.65 0.73	ns
		XC4VFX40	1.82 0.64	2.34 0.78	2.75 1.05	ns
		XC4VFX60	2.42 0.25	3.03 0.35	3.54 0.59	ns
		XC4VFX100	1.99 1.11	2.21 1.31	2.60 1.64	ns
XC4VFX140	N/A	2.80 1.26	3.28 1.61	ns		

Notes:

1. Setup time is measured relative to the Global Clock input signal with the fastest route and the lightest load. Hold time is measured relative to the Global Clock input signal with the slowest route and heaviest load.
2. IFF = Input Flip-Flop or Latch.
3. A Zero "0" Hold Time listing indicates no hold time or a negative hold time. Negative values cannot be guaranteed "best-case," but if a "0" is listed, there is no positive hold time.

ChipSync™ Source-Synchronous Switching Characteristics

The parameters in this section provide the necessary values for calculating timing budgets for Virtex-4 FPGA source-synchronous transmitter and receiver data-valid windows.

Table 59: Duty Cycle Distortion and Clock-Tree Skew

Symbol	Description	Device	Speed Grade			Units
			-12	-11	-10	
T _{DCD_CLK}	Global Clock Tree Duty Cycle Distortion ⁽¹⁾	All	150	150	150	ps
T _{CKSKEW}	Global Clock Tree Skew ⁽²⁾	XC4VLX15	50	60	60	ps
		XC4VLX25	90	100	110	ps
		XC4VLX40	140	160	180	ps
		XC4VLX60	140	160	180	ps
		XC4VLX80	200	230	260	ps
		XC4VLX100	270	310	350	ps
		XC4VLX160	270	310	350	ps
		XC4VLX200	N/A	310	350	ps
		XC4VSX25	50	60	70	ps
		XC4VSX35	90	100	120	ps
		XC4VSX55	140	170	190	ps
		XC4VFX12	50	60	70	ps
		XC4VFX20	60	70	70	ps
		XC4VFX40	90	110	120	ps
		XC4VFX60	140	170	190	ps
		XC4VFX100	200	230	260	ps
XC4VFX140	N/A	310	350	ps		
T _{DCD_BUFR}	I/O clock tree duty cycle distortion	All	100	100	100	ps
	I/O clock tree skew across one clock region	All	50	50	50	ps
T _{BUFIOSKEW}	I/O clock tree skew across multiple clock regions	All	50	50	50	ps
T _{DCD_BUFR}	Regional clock tree duty cycle distortion	All	250	250	250	ps
T _{BUFR_MAX_FREQ}	I/O clock tree MAX frequency	All	710	710	645	MHz
T _{BUFR_MAX_FREQ}	Regional clock tree MAX frequency	All	300	250	250	MHz

Notes:

1. These parameters represent the worst-case duty cycle distortion observable at the pins of the device using LVDS output buffers. For cases where other I/O standards are used, IBIS can be used to calculate any additional duty cycle distortion that might be caused by asymmetrical rise/fall times.
2. The T_{CKSKEW} value represents the worst-case vertical clock-tree skew observable between sequential I/O elements. Significantly less clock-tree skew exists for I/O registers that are close to each other and fed by the same or adjacent clock-tree branches. Use the Xilinx FPGA_Editor and Timing Analyzer tools to evaluate clock skew specific to your application.

Table 60: Package Skew

Symbol	Description	Device	Package	Value	Units
T _{PKGSKEW}	Package Skew ⁽¹⁾	XC4VLX15	SF363	80	ps
			FF668	120	ps
		XC4VLX25	SF363	90	ps
			FF668	110	ps
		XC4VLX40	FF668	110	ps
			FF1148	150	ps
		XC4VLX60	FF668	130	ps
			FF1148	140	ps
		XC4VLX80	FF1148	155	ps
		XC4VLX100	FF1148	140	ps
			FF1513	180	ps
		XC4VLX160	FF1148	145	ps
			FF1513	180	ps
		XC4VLX200	FF1513	180	ps
		XC4VSX25	FF668	90	ps
		XC4VSX35	FF668	100	ps
		XC4VSX55	FF1148	145	ps
		XC4VFX12	SF363	90	ps
			FF668	100	ps
		XC4VFX20	FF672	110	ps
		XC4VFX40	FF672	120	ps
			FF1152	150	ps
		XC4VFX60	FF672	110	ps
			FF1152	170	ps
		XC4VFX100	FF1152	150	ps
			FF1517	170	ps
		XC4VFX140	FF1517	150	ps

Notes:

1. These values represent the worst-case skew between any two balls of the package: shortest flight time to longest flight time from Pad to Ball (7.1 ps per mm).
2. Package trace length information is available for these device/package combinations. This information can be used to deskew the package.

Table 61: Sample Window

Symbol	Description	Device	Speed Grade			Units
			-12	-11	-10	
T _{SAMP}	Sampling Error at Receiver Pins ⁽¹⁾	All	450	500	550	ps
T _{SAMP_BUFIO}	Sampling Error at Receiver Pins using BUFIO ⁽²⁾	All	350	400	450	ps

Notes:

- This parameter indicates the total sampling error of Virtex-4 FPGA DDR input registers across voltage, temperature, and process. The characterization methodology uses the DCM to capture the DDR input registers' edges of operation. These measurements include:
 - CLK0 DCM jitter
 - DCM accuracy (phase offset)
 - DCM phase shift resolution
 These measurements do not include package or clock tree skew.
- This parameter indicates the total sampling error of Virtex-4 FPGA DDR input registers across voltage, temperature, and process. The characterization methodology uses the BUFIO clock network and IDELAY to capture the DDR input registers' edges of operation. These measurements do not include package or clock tree skew.

Table 62: ChipSync Pin-to-Pin Setup/Hold and Clock-to-Out

Symbol	Description	Speed Grade			Units
		-12	-11	-10	
Data Input Setup and Hold Times Relative to a Forwarded Clock Input Pin Using BUFIO					
T _{PSCS} /T _{PHCS}	Setup/Hold of I/O clock across multiple clock regions	-0.45 0.97	-0.45 1.08	-0.44 1.17	ns
Pin-to-Pin Clock-to-Out Using BUFIO					
T _{ICKOFCS}	Clock-to-Out of I/O clock across multiple clock regions	4.10	4.54	5.02	ns

Production Stepping

The Virtex-4 FPGA stepping identification system denotes the capability improvement of production released devices. By definition, devices from one stepping are functional supersets of previous devices. Bitstreams compiled for a device with an earlier stepping are guaranteed to operate correctly in subsequent device steppings.

New device steppings can be shipped in place of earlier device steppings. Existing production designs are guaranteed on new device steppings. To take advantage of the capabilities of a newer device stepping, customers are able to order a new stepping version and compile a new bitstream.

Production devices are marked with a stepping version, with the exception of some step 1 devices. Designs should be compiled with a CONFIG STEPPING parameter set to a specific stepping version. This parameter is set in the UCF file:

CONFIG STEPPING = "#"; (where # is the stepping version)

The default stepping level used by the ISE software is reported in the PAR report.

Table 63 shows the JTAG ID code by step.

Table 63: JTAG ID Code by Step

Device	Step 0	Step 1	Step 2
XC4VLX15		3	5
XC4VLX25		9	A
XC4VLX40		3	5
XC4VLX60		2 or 3	4 or 5
XC4VLX80		3	5
XC4VLX100		2 or 3	4 or 5
XC4VLX160		0 or 3	4 or 5
XC4VLX200		0 or 3	2 or 5
XC4VSX25		2	4
XC4VSX35		2	4
XC4VSX55		2	4
XC4VFX12	0 or 2		
XC4VFX20	2	6	
XC4VFX40		0	
XC4VFX60	2	8	
XC4VFX100	0	6	
XC4VFX140	0	4	

Notes:

- Shaded cells represent devices not produced at that stepping.

Current Virtex-4 Production Devices

Table 64 summarizes the current production LX and SX device stepping.

Table 64: Current LX and SX Production Devices

LX/SX Device Stepping	Step 1	Step 2
Example Ordering Code	XC4VLX60-10FF672C	XC4VLX60-10FF672CS2
Device steppings shipped when ordered per Example Ordering Code	Step 1 or Step 2	Step 2
Capability Improvements ⁽¹⁾	<ul style="list-style-type: none"> The DFS macro is no longer needed 	<ul style="list-style-type: none"> T_{CONFIG} requirement is removed DCM_RESET requirement is removed DCM_INPUT_CLOCK_STOP requirement is removed by a macro (automatically inserted by ISE software)
CONFIG STEPPING parameter (must be set in UCF file)	“1”	“2”
Minimum Software Required	ISE 7.1i SP4	ISE 7.1i SP4
Minimum Speed Specification Required.	1.58	1.58

Notes:

- See LX and SX Errata for details on LX and SX Step 1 and ES silicon.

Table 65 summarizes the current production FX device stepping.

Table 65: Current FX Production Devices

FX Device Stepping	Step 0	Step 1
Example Ordering Code	XC4VFX60-10FF1152C	XC4VFX60-10FF1152CS1
Device steppings shipped when ordered per Example Ordering Code	Step 0 or Step 1	Step 1
Capability Improvements		See FX Errata for details
CONFIG STEPPING parameter (must be set in UCF file)	“0”	“0” or “1”
Minimum Software Required	ISE 8.1i SP2	ISE 8.1i SP2
Minimum Speed Specification Required	1.58	1.58

Notes:

- Speed Specification v1.65 or later must be used for XC4VFX40 devices (all speed grades) and for XC4VFX100 (-12 speed grade only). In this case, these family members (and speed grades) are released to production before a speed specification is released with the correct label (Advance, Preliminary, or Production). These labeling discrepancies will be corrected in a subsequent speed specification release.

Revision History

The following table shows the revision history for this document.

Date	Version	Revisions
08/02/04	1.0	Initial Xilinx release. Printed Handbook version.
09/09/04	1.1	Edits in Tables 12, 13, 18, 19, 20, 22, 26, 28, 37, and 38. Removed Table 39.
01/18/05	1.2	Added parameters to Tables 4 and 5. Removed System Monitor and ADC parameters.
02/01/05	1.3	Changed parameters in Tables 1, 2, 3, 7, and 11. Added Interface Performance Characteristics section. Added Switching Characteristics section and Table 14. Added parameters to the following tables: 4–6, 14, 16–30, 32–40, and 46.
02/24/05	1.4	Changed the notes in Table 2. Added Set/Reset parameters to Table 32 and Table 33. Changed description in Table 35. Changed Set/Reset in Table 37. Changed PSCLK units in Table 45. Added parameters to Table 46. Changed DCM_TAP_MS_MIN in Table 50.
05/19/05	1.5	Added RocketIO and PowerPC parameters to Table 1, Table 2, and Table 3. Removed conditions from V_{IDIFF} and V_{ICM} in Table 9. Revised Table 13. Added RocketIO DC Input and Output Levels section. Added PowerPC Switching Characteristics section. Added RocketIO Switching Characteristics section. Removed Table 31 from version 1.4. Revised Table 35. Along with changes to Table 43 and Table 50, there are three new requirements to ensure maximum operating frequencies for the DCM. Added parameters to Table 54, Table 55, Table 56, Table 58, Table 59, Table 60, Table 61, Table 62.
06/17/05	1.6	Revised V_{IN} and V_{TS} in Table 1 and Note 4. Revised typical P_{CPU} specification in Table 3. Revised symbols and values in the Processor tables: Table 16 through Table 22. Revised T_{DCREF} in Table 24. Corrected the CLKOUT_FREQ_FX_HF_MS_MIN in Table 45, the CLKOUT_FREQ_FX_LF_MR_MIN in Table 46, and the “Input Clock Period Jitter” in Table 47. Corrected units in Table 59.
06/27/05	1.7	Changed V_{IL} and V_{IH} for LVCMOS15 in Table 7. Revised Table 14. Replaced value for V_{EYE} in Table 25. Added Note 4 to Table 50. Added Table 57: Global Clock Setup and Hold for LVCMOS25 Standard, with DCM in Source-Synchronous Mode . Added value for XC4VLX160-FF1513 in Table 60. Added values for -12 speed specifications to most of the tables. Revised the -10 and -11 speeds in most of the switching characteristics tables.
08/06/05	1.8	Updated to speed specification v1.56. Added V_{CC_CONFIG} note to Table 2. Clarified design information in Table 13. Corrected $T_{PROGRAM}$ in Table 43. Added DRP configuration timing for DCMs to Table 43. Added global clock tree maximum frequency to Table 44. Corrected CLKOUT_FREQ_FX_LF_MS_MIN in Table 45. Added footnotes 3 and 4 to Table 45 and Table 46. Added more data to the T_{CKSKEW} in Table 59.
08/29/05	1.9	Corrected V_{OCM} in Table 8. Revised Table 11. Added RocketIO MGT Clock DC Input Levels to Table 12. Revised SFI-4.1 performance values in Table 13. Added software tools requirements ISE7.1i SP4, to description above Table 14. Added -11X speed grade to Table 14 and Table 23. Edited Table 15 and Table 16. Edited Table 24. Added note 2 to Table 25, and moved $RXOOB_{VDPP}$ to Table 12. Added conditions to T_{DJ} and T_{RJ} in Table 26. Moved $TXOOB_{VDPP}$ to Table 12. Added RSDS to Table 27. Added note 4 to Table 49. Added Production Stepping section.
09/28/05	1.10	Table 2: Removed Note 1. Recommended maximum voltage drop for V_{CCAUX} is 10 mV/ms.

Date	Version	Revisions
02/03/06	1.11	Revised the speed specification requirements in Switching Characteristics , page 12, with parameter changes in Table 54 and Table 56 . Added Note 7 to Table 2 . Added to the I_{RPU} and I_{RPD} specifications in Table 3 . Changed LVCMOS18 to meet the JEDEC specification in Table 7 . Inserted notes into Table 8 , Table 9 , and Table 10 . Corrected note 1 in Table 11 . In Table 12 , revised Common Mode Input Voltage Range (V_{ICM}) typical from 800 mV to 600 mV and added a new Note 1. Also in Table 12 , changed Common Mode Voltage specification from 95mV to 950mV. Changed performance numbers in Table 23 . Removed the typical specification for T_{DJ} from Table 26 . Added note 2 to Table 27 . In Table 35 , added maximum to $T_{IDELAYCTRLCO_RDY}$, and a new parameter $T_{IDELAYPAT_JIT}$. Revised Note 1 in Table 43 . Added note 5 to Table 45 . Revised notes 3 and 5 in Table 50 . Changed the $CLKIN_FREQ_PMCD_CLKA_MAX$ -12 specification in Table 53 . Changed the $T_{BUFIO_MAX_FREQ}$ specification in Table 59 . Changed the information in the Production Stepping and Current Virtex-4 Production Devices sections.
03/22/06	1.12	Modified second paragraph in Power-On Power Supply Requirements . Added/Changed numbers for $I_{CCINTMIN}$, $I_{CCAUXMIN}$, and I_{CCOMIN} , and added Note 2 (Table 5). Changed the typ value of the DC Parameter, Common Mode Input Voltage Range from 600 MV to 800 MV in Table 12 . Added three DC parameters to Table 12 , Input Common-Mode Voltage (V_{ICMC}), Peak-to-Peak Differential Input Voltage (V_{IDIFF}), and Differential Input Resistance (R_{IN}). Changed the SPI4.2 entry for -11 from 900 Mb/s to 1 Gb/s in Table 13 . Added Note 3 to Table 15 . Reduced the maximum frequency from 322 MHz to 250 MHz (in Table 25 and Table 26). Added Note 5 to Table 40 .
06/01/06	1.13	Changed V_{IN} and V_{TS} values and added notes to Table 1 , page 1. Removed -11X speed grade from Table 14 . Updated to speed specification v1.60. Removed -11X speed grade, changed the -12 and -11 speed grade to 6.5 Gb/s, and deleted Note 1 in Table 23 , page 16. Deleted first condition and changed second condition to 2.5 Gb/s to 6.5 Gb/s for Reference Clock total jitter, peak-peak (T_{GJTT}) in Table 24 , page 16. Changed the max value for Serial data rate F_{GTX} to 6.5 Gb/s. Deleted first condition and changed second condition to 2.5 Gb/s to 6.5 Gb/s for Serial data output deterministic jitter (T_{DJ}) and deleted first condition and changed second condition to 2.5 Gb/s to 6.5 Gb/s for Serial data output random jitter (T_{RJ}), both in Table 26 , page 18.
06/23/06	1.14.1	Virtex-4 FPGA Electrical Characteristics , page 1: removed paragraph on that introduced the -11x for XC4VFX devices. Table 3 , page 3: added new values for $I_{CCAUXRX}$, I_{CCAUTX} , $I_{CCAUXMGT}$, I_{TTX} , I_{TRX} , and new notes 2 and 3. Table 4 , page 4: added new symbols and for values $I_{CCAUXRX}$, I_{CCAUTX} , I_{TTX} , I_{TRX} , I_{AUMGT} and new notes 4 and 5. Table 12 , page 11: changed DC parameters and values and added note. Table 14 : changed speed designations for the XC4VFX devices. Table 24 , page 16 and Table 25 , page 17, for most characteristics: changed conditions, speed grade (typ and max) values, and units. Table 26 , page 18, for most characteristics: changed conditions, speed grade (typ and max) values, and units. Updated notes. Table 43 , page 36: removed the Tcnfig symbol, values, and note 1. Note 2 is now Note 1, and the reference has also been changed. Table 50 , page 42: removed Input Signal Requirements. Table 54 , page 44, Table 55 , page 45, Table 56 , page 46, Table 57 , page 47, and Table 58 , page 48: corrected large speed numbers to N/A.
08/23/06	1.15	Table 24 , page 16: changed value for Reference Clock Rise/Fall Time (T_{RCLK} ; T_{FCLK}) from 65 ps Typ to 400 ps Max. Table 35 , page 29: changed the speeds specification for the -12, -11, and -10 Speed Grades for $T_{IDELAYRESOLUTION}$, deleted row for $T_{IDELAYRESOLUTION_ERR}$ and added row for $T_{IDELAYTOTAL_ERR}$. Table 39 , page 32: changed the speeds specification for -12 Speed Grades, Sequential Delay characteristics: T_{REG} , T_{REGXB} , T_{REGYB} , T_{CKSH} , and T_{REGF5} . Table 65 , page 52: added stepping information for Virtex-4 FX devices.

Date	Version	Revisions
09/07/06	1.16	<p>Added 2.5V rows to V_{IN} and V_{TS} (Table 1, page 1). Updated value DV_{IN} from 200 mV to 110 mV in Table 12, page 11. Updated speed grade specifications for XCV4FX devices in Table 14. Updated jitter tolerance and V_{EYE} in Table 25, page 17. Corrected equation for $T_{IDELAYTOTAL_ERR}$ in Table 35, page 29.</p>
10/06/06	1.17	<ul style="list-style-type: none"> • SPEED SPECIFICATION version for this data sheet release: v1.62. • Table 1: Removed former note 3 on V_{IN}. • Table 14: Moved XC4VFX12-11, XC4VFX20-11, XC4VFX60-11, and XC4VFX100-11 devices to Production status. • Table 15: Expanded to break out processor clock specifications into <i>Characteristics when APU Not Used</i> and <i>Characteristics when APU Used</i>. Removed specs for CPMFCMCLK, not available. • Table 25, Table 26: Updated RX and TX jitter data and notes. • Table 39: Modified T_{REGXB}, T_{REGYB}, and T_{CKSH} timing parameters to comply with v1.62 speed specification.
12/11/06	2.0	<ul style="list-style-type: none"> • SPEED SPECIFICATION version for this data sheet release: v1.62. • Table 1: Modified Note (3) referring to 3.3V I/O design guidelines. Added I_{IN} parameters. • Table 2: Corrected recommended V_{TRX} range to 0.25V – 2.5V. Added I_{IN} parameters. • Table 7: Added LVDCI attributes with LVCMOS. • Table 13: Added Note (1) for SDR LVDS Interface requiring AC coupling above 622 MHz. Added DDR2 SDRAM (High-Performance SERDES Design) with reference to XAPP721. Updated all specification values. • Pin-to-Pin Performance and Register-to-Register Performance tables (formerly Table 13 and Table 14) deleted. • Table 14: XC4VFX12 changed to Production status. • Table 15: Added APU-used max characteristics for -12 devices. • Table 24: Added values for Spread-Spectrum Clocking and footnote. • Table 26: Changed symbol for jitter parameters from T_J, R_J, and D_J to T_J, R_J, and D_J respectively. • Table 32: Added Note (1) to refer to Timing Report for non-zero tap values. Made DLY setup/hold parameters relative to C, not CLKDIV. • Table 34: Amended Note (1) to refer to Timing Report for non-zero tap values. • Table 35: Added Note (1) to refer to XAPP707 for details on IDELAY timing characteristics. Changed $T_{IDELAYRESOLUTION}$ from 74 ps to 75 ps to match Timing Analyzer. Modified formula for $T_{IDELAYTOTAL_ERR}$ to use 75 ps resolution. • Table 40: Added CLK-to-DOUT parameters for “with ECC” case. Added CLK-to-CLK parameter. • Table 43, Table 44, Table 59: Added configuration parameter values for -12 speed grade. • Table 45: Added F_{MAX} for -12 speed grade. • Table 45, Table 46, Table 47: Added Note (6) stating that CLKIN values for DLL only also apply to DLL and DFS together. • Table 46, Table 47: Replicated Note (5) from Table 45 and applied to all CLKIN with DLL parameters. • Table 47, Table 50: Added notes to clarify boundary-frequency cases. • Table 48: Modified Note (1) to point to the architecture wizard for CLKFX output jitter. Added Note (2) to indicate that PMCD outputs introduce no jitter.

Date	Version	Revisions
12/11/06 (Cont'd)	2.0 (Cont'd)	<ul style="list-style-type: none"> • Table 50: Removed T_LOCK_FX_MIN parameter. Added DCM_RESET. • Table 53: Added Note (1), no minimum frequency for PMCD. • Table 64: Added Note (1) to refer to LX and SX Errata for capability improvements.
03/27/07	2.1	<ul style="list-style-type: none"> • SPEED SPECIFICATION version for this data sheet release: v1.64. • Table 4: Added Note (6) regarding max quiescent supply current. • Table 5: Filled in missing power-on current values for FX devices. • Table 24: Added new parameter F_GREFCLK. Added Min value for Spread Spectrum Clocking frequency. Corrected “Conditions”. • Table 26: Revised Notes (2) and (3). • Table 37, Table 38: Added column/values for XC4VFX -12. • Table 39: Added columns/values for XC4VFX -11 and -12. Corrected XC4VLX/SX -11 and -12 values for T_REGXB, T_REGYB, and T_CKSH. • Table 43: Restored parameter T_CONFIG and footnote (1) from earlier revision. Added new parameter T_SMCO (SelectMAP Readback Clock-to-Out). • Table 50: Restored DCM_RESET Minimum and DCM_INPUT_CLOCK_STOP parameters from earlier revision. Added Notes (4) through (7) to these parameters. • Table 60: Removed FF1760 package. Not supported. • Table 63: Added FX devices and JTAG IDs.
06/08/07	2.2	<ul style="list-style-type: none"> • SPEED SPECIFICATION version for this data sheet release: v1.65. • Table 14: Promoted -12 speed grade devices of XC4VFX12, XC4VFX20, and XC4VFX60 to Production status. • Table 37: Removed parameter T_ISCCK_REV. Not meaningful because pin should always be connected to GND. • Table 43: Added parameter F_MAX_SELECTMAP for maximum Slave SelectMAP mode external configuration clock frequency. • Table 63: Filled in Step 1 values for XC4VFX20, XC4VFX60, and XC4VFX100. • Table 65: Added Step 1 data.
08/10/07	2.3	<ul style="list-style-type: none"> • SPEED SPECIFICATION version for this data sheet release: v1.65. • Table 3: Added MAX value for I_BATT. • Table 25: Added unit (ns) to RXSIGDET. • Table 27: Added Note (3) specifying range of DCI reference resistors and referring to UG070. • Added section Ethernet MAC Switching Characteristics, page 22, and replaced Table 29. • Added section I/O Standard Adjustment Measurement Methodology, page 23, including Table 30, Table 31, and Figure 4. • Table 43: Added parameter F_MAX_ICAP. Added word “Data” to description of SelectMAP Setup/Hold. • Table 64: Added to Capability Improvements, for Step 1 that the DFS macro is no longer needed.
09/10/07	2.4	<ul style="list-style-type: none"> • SPEED SPECIFICATION version for this data sheet release: v1.67. • Table 14: Promoted all speed grades for XC4VFX40 devices, and -12 speed grade for XC4VFX100 devices, to Production status. • Table 63: Filled in Step 1 value for XC4VFX40. • Table 65: Added Note 1.

Date	Version	Revisions
09/28/07	3.0	<ul style="list-style-type: none"> • SPEED SPECIFICATION version for this data sheet release: v1.67. • Promoted data sheet to Production status. • Table 14: Moved XC4VFX140, all speed grades, from Advance to Production status. • Table 59: Added/updated all Global Clock Tree Skew values. Qualified Note (2) by adding “vertical”. • Table 60: Added Package Skew values for XC4VFX40, XC4VFX100, and XC4VFX140. • Table 63: Added JTAG ID code for XC4VFX140.
12/11/07	3.1	<ul style="list-style-type: none"> • SPEED SPECIFICATION version for this data sheet release: v1.68. • Added new copyright notice and legal disclaimer section. • Table 13: Removed table note references to XAPP700, XAPP704, and XAPP705 (obsolete). Renumbered table notes. • Table 15: Added new Note 1, renumbered subsequent table notes. • Table 30: Removed table rows for LVPECL_33, LVDS_33, and LVDSEXT_33. • Table 30, Table 31: Corrected “electron-coupled” to “emitter-coupled”. • Table 31: For LVDS Extended Mode 2.5V, corrected I/O Standard Attribute to LVDSEXT_25. • Table 37: Added Note 4 specifying F_{TOG} for -11 FX devices as 1181 MHz. • Table 43: Added parameter $F_{MAX_READBACK}$. • Table 58: Corrected T_{PSFD} for XC4VFX100 devices to 1.99 ns. • Section Production Stepping, page 51: Advised that current stepping level is reported by the ISE tool in the PAR report.
04/10/08	3.2	<ul style="list-style-type: none"> • SPEED SPECIFICATION version for this data sheet release: v1.68. • Table 28, page 22: Re-inserted table. • Table 43, page 36: Updated Symbol names for the DRP entries. • Table 63, page 51: Revised code for XC4VFX40 package to 0.
06/06/08	3.3	<ul style="list-style-type: none"> • SPEED SPECIFICATION version for this data sheet release: v1.68. • Table 3, page 3: In Note (2), clarified differences between settings for typical and maximum I_{CC} numbers. • Table 24, page 16: Revised F_{GCLK} to show different maximum frequencies depending on the speed grade. Removed T_{PHASE}. • Table 35, page 29: Reorganized according to IDELAYCTRL and IDELAY.
11/26/08	3.4	<ul style="list-style-type: none"> • Table 35, page 29: Added F_{MAX}.
06/16/09	3.5	<ul style="list-style-type: none"> • Table 40, page 33: Changed T_{RCKO_DOA} to a Max parameter.
08/13/09	3.6	<ul style="list-style-type: none"> • Table 3, page 3: Updated Note 1. • Table 45, page 38: Added Note 6 reference to and updated descriptions of CLKIN_FREQ_DLL_HF_MS_MIN and CLKIN_FREQ_FX_HF_MS_MAX.
09/09/09	3.7	<ul style="list-style-type: none"> • Table 7, page 8: Added “LVCMOS” to Notes 3 and 4.

Notice of Disclaimer

THE XILINX HARDWARE FPGA AND CPLD DEVICES REFERRED TO HEREIN (“PRODUCTS”) ARE SUBJECT TO THE TERMS AND CONDITIONS OF THE XILINX LIMITED WARRANTY WHICH CAN BE VIEWED AT <http://www.xilinx.com/warranty.htm>. THIS LIMITED WARRANTY DOES NOT EXTEND TO ANY USE OF PRODUCTS IN AN APPLICATION OR ENVIRONMENT THAT IS NOT WITHIN THE SPECIFICATIONS STATED IN THE XILINX DATA SHEET. ALL SPECIFICATIONS ARE SUBJECT TO CHANGE WITHOUT NOTICE. PRODUCTS ARE NOT DESIGNED OR INTENDED TO BE FAIL-SAFE OR FOR USE IN ANY APPLICATION REQUIRING FAIL-SAFE PERFORMANCE, SUCH AS LIFE-SUPPORT OR SAFETY DEVICES OR SYSTEMS, OR ANY OTHER APPLICATION THAT INVOKES THE POTENTIAL RISKS OF DEATH, PERSONAL INJURY, OR PROPERTY OR ENVIRONMENTAL DAMAGE (“CRITICAL APPLICATIONS”). USE OF PRODUCTS IN CRITICAL APPLICATIONS IS AT THE SOLE RISK OF CUSTOMER, SUBJECT TO APPLICABLE LAWS AND REGULATIONS.

Looking for pricing, stock, or lifecycle information?

Click below to explore more details on WIN SOURCE:

 [View XC4VSX55-10FFG1148C on WIN SOURCE](#)

 [Xilinx Inc. Information](#)

Optimize Your Supply Chain with WIN SOURCE Solutions

-  Global Sourcing Solution
-  Obsolete Management
-  Cost Control Management
-  Shortage Management
-  Alternative Solution
-  Excess Inventory Management