



**THE DATASHEET OF
AAT2606IWO-1-T1**



Six-Channel 300mA LDO Regulator

General Description

The AAT2606 is a member of Skyworks' Total Power Management IC (TPMIC™) product family. It contains six fully integrated 300mA low dropout (LDO) regulators in a small, Pb-free 14-pin 3mm x 3mm TDFN package, making it ideal for space-constraint systems.

The AAT2606 features low power consumption, low dropout, and high noise immunity from the input power supply. Each channel consumes a mere 30µA of current when enabled and features 250mV of dropout at 250mA and 68dB of power supply rejection at 10kHz. Each channel has its own enable pin and uses a small 1µF output capacitor. Output voltages are factory One Time Programmable (OTP) between 0.6V and 3.7V with 100mV increment and typical regulation accuracy is ±1%.

The AAT2606 is a safe solution that integrates an over-current limit for each channel and over-thermal protection. The device is rated over a temperature range of -40°C to 85°C.

Features

- 2.7V to 5.5V Operating Input Voltage Range
- 6 Outputs with Factory Programmable Voltages from 0.6V to 3.7V
- 300mA Output Current per Channel
- 3mm x 3mm, 14-Pin TDFN Package
- ±1% Typical Accuracy
- Low 30µA Quiescent Current
- High PSRR (68dB @10KHZ)
- 250mV Dropout Voltage at 250mA
- Independent Enable
- Over-Current Protection
- Over-Thermal Protection

Applications

- Portable Navigation Devices (PND)
- Cellular Application
- Handheld Products
- Media Players (MP4 Players)

Typical Application

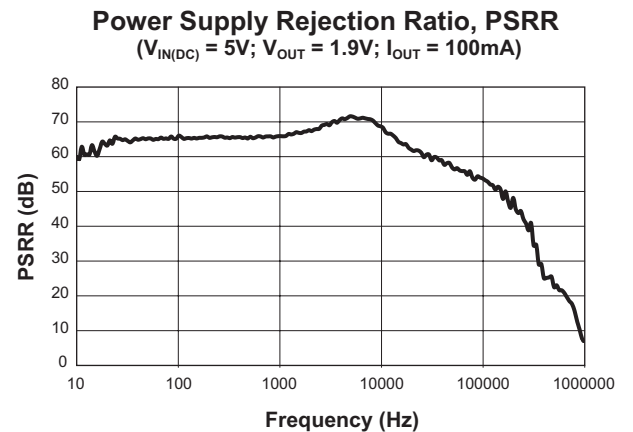
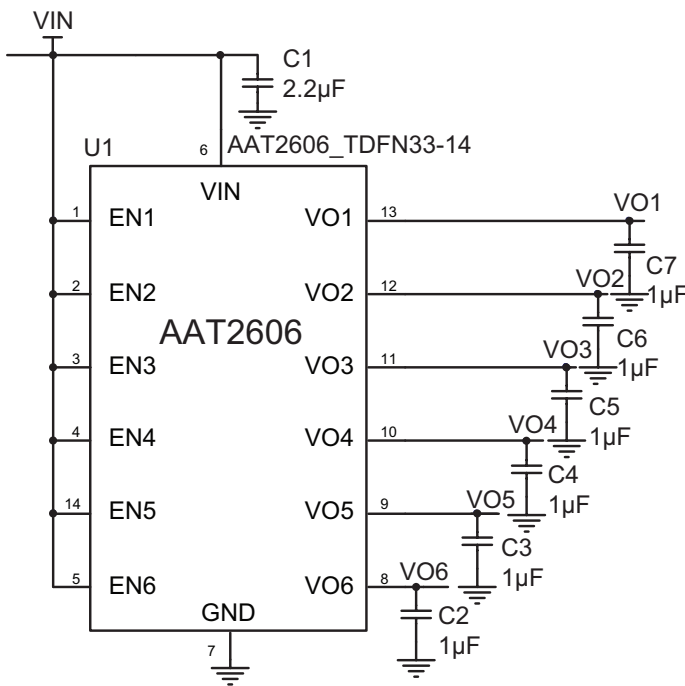

AAT2606

Six-Channel 300mA LDO Regulator

Pin Descriptions

Pin #	Symbol	Function
1	EN1	LDO1 enable, active high.
2	EN2	LDO2 enable, active high.
3	EN3	LDO3 enable, active high.
4	EN4	LDO4 enable, active high.
5	EN6	LDO6 enable, active high.
6	VIN	Input to power control circuit and all LDOs.
7	GND	Ground.
8	VO6	LDO6 output voltage.
9	VO5	LDO5 output voltage.
10	VO4	LDO4 output voltage.
11	VO3	LDO3 output voltage.
12	VO2	LDO2 output voltage.
13	VO1	LDO1 output voltage.
14	EN5	LDO5 enable, active high.

Pin Configuration

**TDFN33-14
(Top View)**

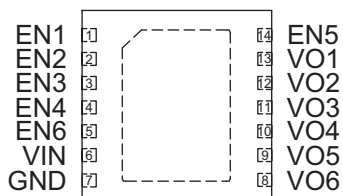

AAT2606*Six-Channel 300mA LDO Regulator***Absolute Maximum Ratings¹**

Symbol	Description	Value	Units
V_{IN}	VIN, EN1, EN2, EN3, EN4, EN5, EN6 to GND	-0.3 to 6.5	V

Thermal Information²

Symbol	Description	Value	Units
θ_{JA}	Thermal Resistance	50	°C/W
P_D	Maximum Power Dissipation	2	W
T_J	Operating Temperature Range	-40 to 150	°C
T_S	Storage Temperature Range	-65 to 150	
T_{LEAD}	Maximum Soldering Temperature (at leads, 10 sec)	300	

1. Stresses above those listed in Absolute Maximum Ratings may cause permanent damage to the device. Functional operation at conditions other than the operating conditions specified is not implied. Only one Absolute Maximum Rating should be applied at any one time.
2. Mounted on an FR4 board.

DATA SHEET

AAT2606

Six-Channel 300mA LDO Regulator

Electrical Characteristics¹

$V_{IN} = 5.0V$, $-40^{\circ}C \leq T_A \leq +85^{\circ}C$, unless noted otherwise. Typical values are $T_A = 25^{\circ}C$.

Symbol	Description	Conditions	Min	Typ	Max	Units
Logic Control / Protection						
V_{ENx}	Input High Threshold		1.4			V
	Input Low Threshold				0.3	V
Input Supply						
V_{IN}	Input Voltage Range		2.7		5.5	V
UVLO	Under-Voltage Lockout Threshold	Falling		2		V
		Rising		2.2		
Low-Dropout Regulator (LDO1:LDO6)						
V_{LDO}	LDO Output Voltage	$I_{LDO} = 1mA$ to $250mA$, OTP per requirement	0.6V		$V_{IN} - V_{DO}$	V
	LDO Accuracy	$I_{LDO} = 10mA$	-3		+3	%
I_Q	LDO Quiescent Current	$V_{IN} = 5V$, added quiescent current when LDO is enabled		30	55	μA
I_{SHDN}	Shutdown Current	$V_{IN} = 5.0V$, EN = GND		1		μA
	Line Regulation	$I_{LDO} = 10mA$		0.1		%/V
V_{DO}	Dropout Voltage	$I_{LDO} = 250mA$		250	500	mV
PSRR	Power Supply Rejection Ratio	$V_{IN} = 5.0V$, EN = High, $I_{LDO} = 100mA$, $f = 10KHz$, $V_{ox} = 1.8V$		68		dB
$I_{LDO(LIM)}$	LDO Current Limit		300			mA
Thermal						
T_{SD}	Over-Temperature Shutdown Threshold	Rising		145		$^{\circ}C$
T_{HYS}	Over-Temperature Shutdown Hysteresis			25		$^{\circ}C$

1. Specification over the $-40^{\circ}C$ to $+85^{\circ}C$ operating temperature range is assured by design, characterization and correlation with statistical process controls.

AAT2606

Six-Channel 300mA LDO Regulator

Programming Output Voltages via OTP

Regulator	Output Voltage Range		Resolution
LDO1	0.6V	3.7V	100mV
LDO2	0.6V	3.7V	100mV
LDO3	0.6V	3.7V	100mV
LDO4	0.6V	3.7V	100mV
LDO5	0.6V	3.7V	100mV
LDO6	0.6V	3.7V	100mV

Block Diagram

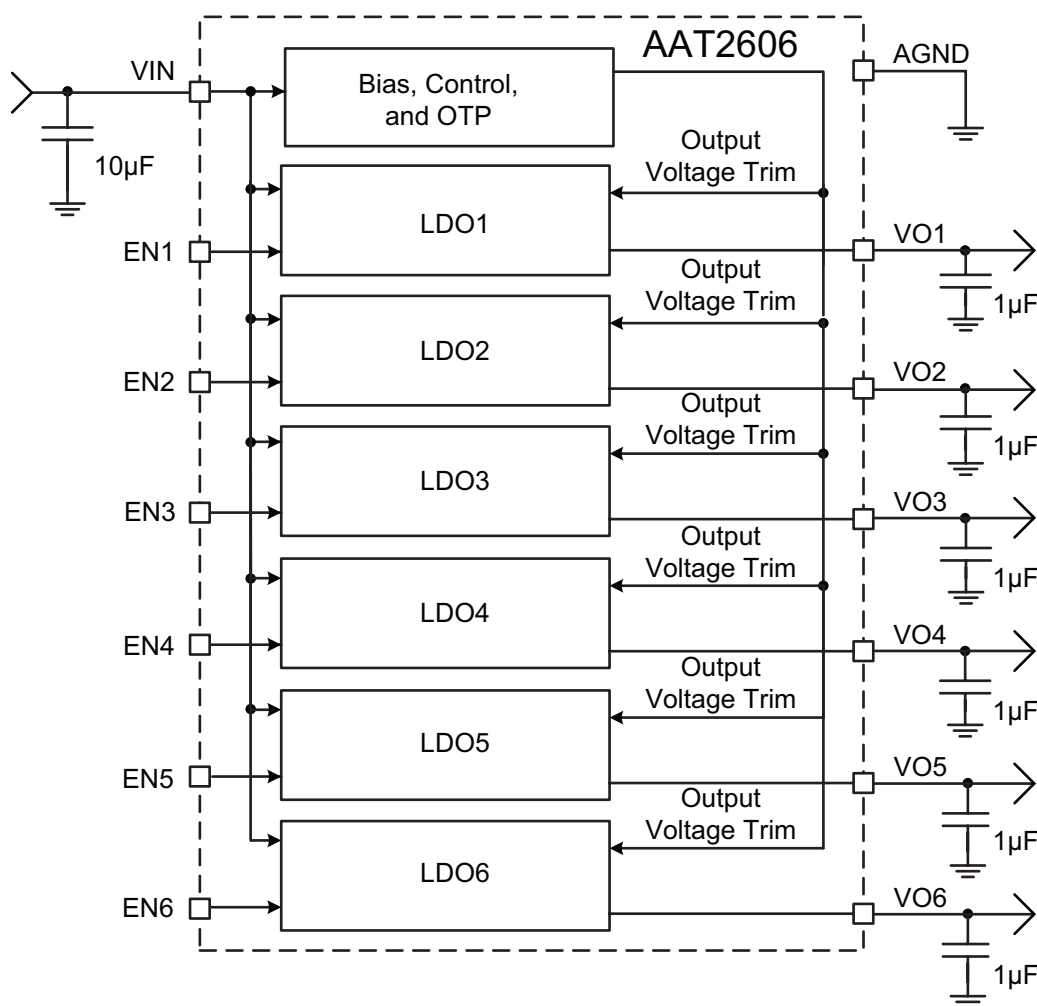

Typical Characteristics

Load Regulation
($V_{OUT} = 1V$)

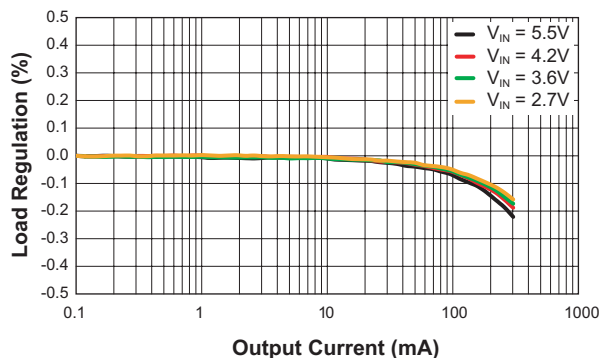

Load Regulation
($V_{OUT} = 3V$)

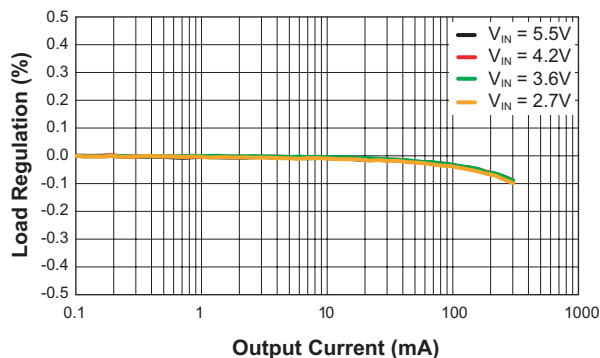

Line Regulation
($V_{OUT} = 1V$)

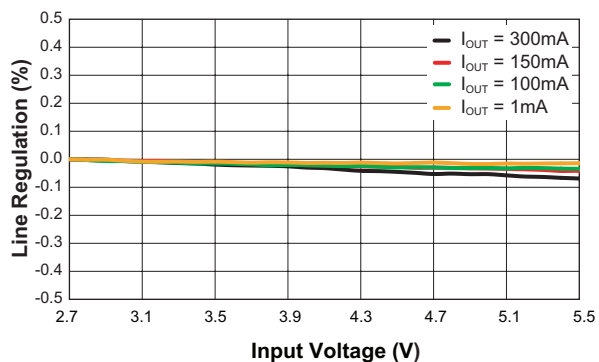

Line Regulation
($V_{OUT} = 3V$)

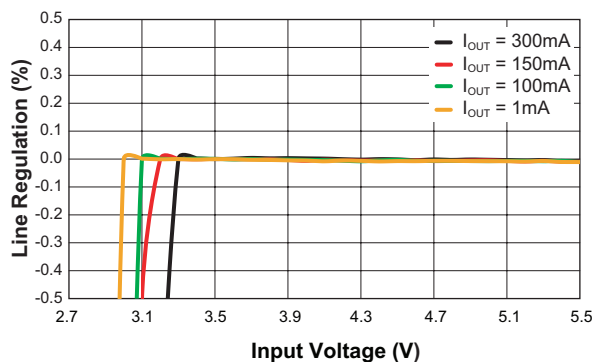

Output Voltage Error vs. Temperature
(LDO $V_{OUT} = 1V$)

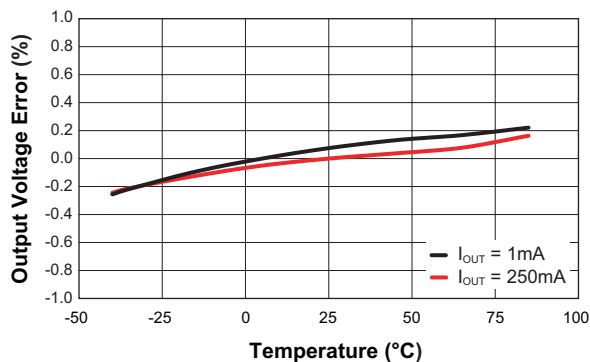

Output Voltage Error vs. Temperature
(LDO $V_{OUT} = 3V$)

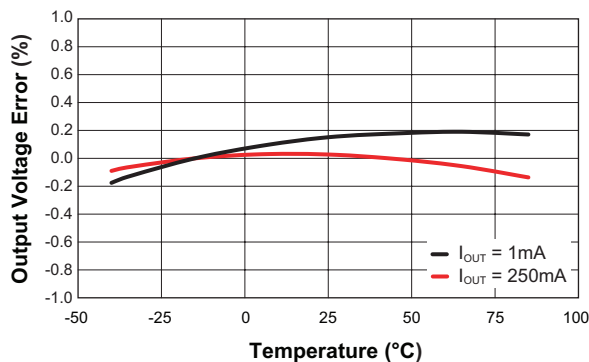

Typical Characteristics

Supply Current vs. Supply Voltage
(Contributed By Each LDO)

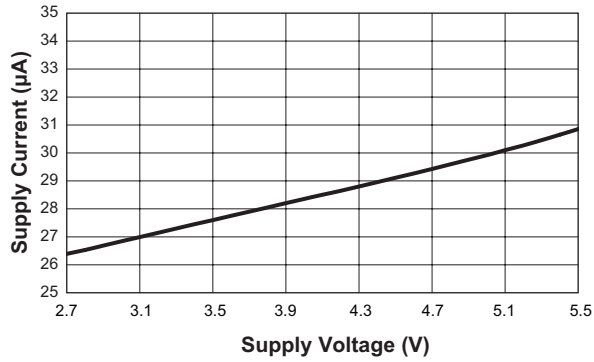

Load Transient
($V_{OUT} = 1.85V$; $V_{IN} = 3.6V$; $I_{OUT} = 30mA$ to $300mA$)

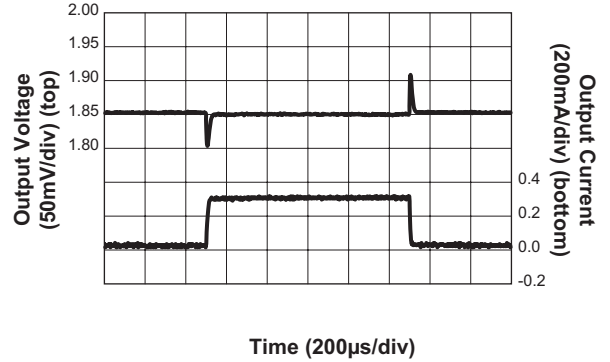

Power Supply Rejection Ratio, PSRR
($V_{IN(DC)} = 5V$; $V_{OUT} = 1.9V$; $I_{OUT} = 100mA$)

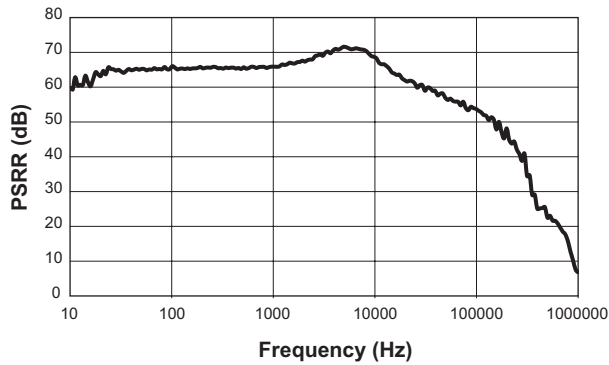

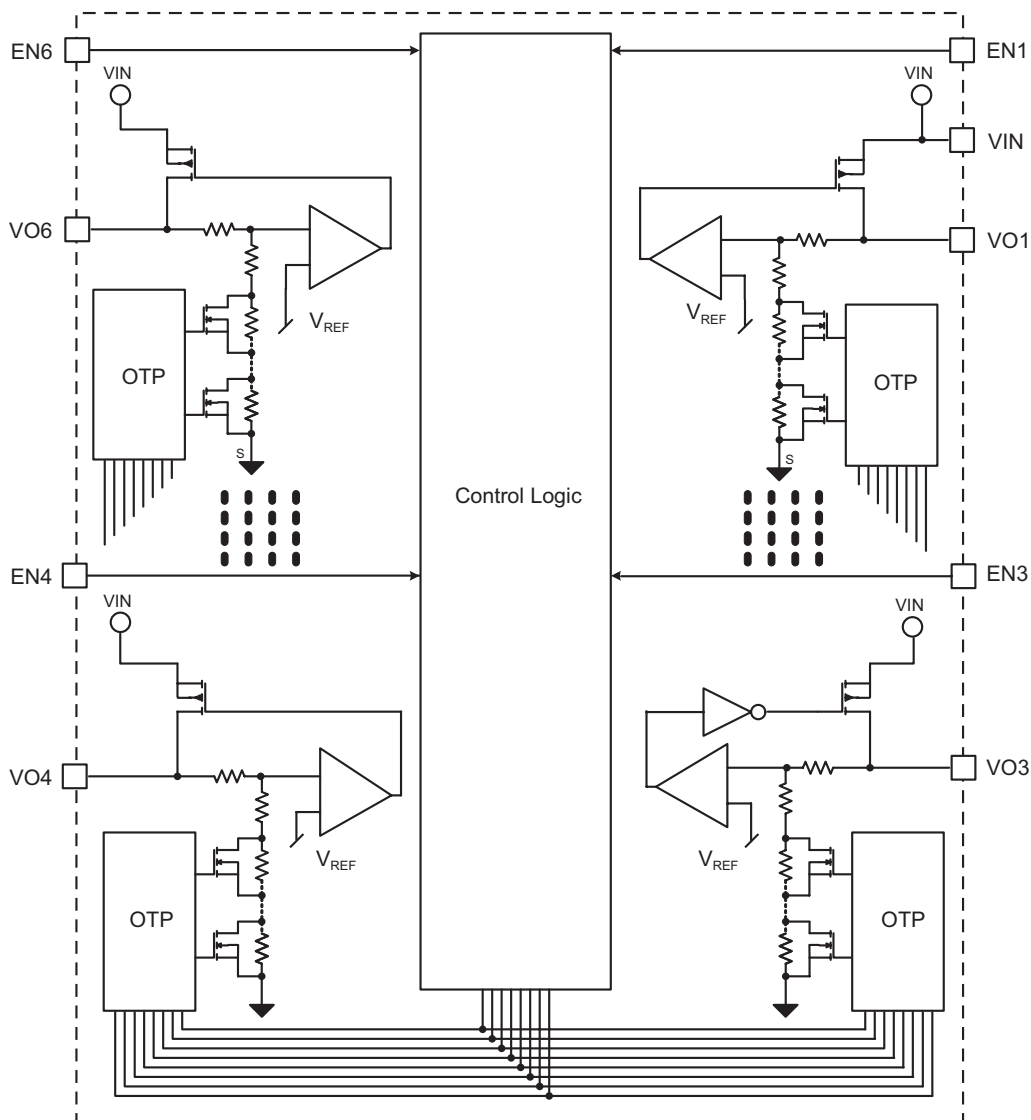
Functional Block Diagram**Functional Description**

The AAT2606 includes six LDO regulators. The regulators operate from the 2.7V to 5.5V input voltage to a regulated output voltage. Each LDO regulator has its own independent enable pin. The LDO regulators have a fixed output programmed during manufacturing. Each LDO consumes 30 μ A of quiescent current and is stable with a small 1.0 μ F ceramic output capacitor. These LDOs offer high power supply rejection, over-current protection and over-temperature protection.

Application Information**Input Capacitor**

Typically, a 2.2 μ F or larger ceramic capacitor is recommended for C_{VIN} in most applications. The input capacitor should be located as close to the input (V_{IN}) of the device as practically possible. C_{VIN} values greater than 2.2 μ F will offer superior input line transient response and will assist in maximizing the highest possible power supply ripple rejection.

Six-Channel 300mA LDO Regulator**Output Capacitor**

For proper load voltage regulation and operational stability, a capacitor is required between the VOUT and GND pins. The C_{OUT} capacitor connection to the LDO regulator ground pin should be made as direct as practically possible for maximum device performance.

The AAT2606 LDO regulators have been specifically designed to function with very low ESR ceramic capacitors. Although the device is intended to operate with these low ESR capacitors, it is stable over a very wide range of capacitor ESR, thus it will also work with higher ESR tantalum or aluminum electrolytic capacitors. However, for best performance, ceramic capacitors are recommended.

Typical output capacitor values for maximum output current conditions range from 1μF to 10μF.

Thermal Calculations

There are two types of losses associated with the AAT2606 total power management solution [six LDO regulators]: conduction losses, and quiescent current losses. Conduction losses are associated with the power loss of the voltage difference across the pass switch/FET of the six LDO regulators. At full load, a simplified form of the losses is given by the following (quiescent losses are ignored, since conduction losses are so dominant):

$$P_{LDO1} = I_{LDO1} \cdot (V_{IN} - V_{O1})$$

$$P_{LDO2} = I_{LDO2} \cdot (V_{IN} - V_{O2})$$

$$P_{LDO3} = I_{LDO3} \cdot (V_{IN} - V_{O3})$$

$$P_{LDO4} = I_{LDO4} \cdot (V_{IN} - V_{O4})$$

$$P_{LDO5} = I_{LDO5} \cdot (V_{IN} - V_{O5})$$

$$P_{LDO6} = I_{LDO6} \cdot (V_{IN} - V_{O6})$$

$$P_{TOTAL} = P_{LDO1} + P_{LDO2} + P_{LDO3} + P_{LDO4} + P_{LDO5} + P_{LDO6}$$

Layout

The suggested PCB layout for the AAT2606 is shown in Figures 2 and 3. The following guidelines should be used to help ensure a proper layout.

1. The input capacitors (C1 should connect as closely as possible to VIN (Pin 6) and GND (Pin 7).
2. The resistance of the trace from the load return to the GND (Pins 7) should be kept to a minimum. This will help to minimize any error in DC regulation due to differences in the potential of the internal signal ground and the power ground.
3. For good thermal coupling, PCB vias are required from the pad for the TDFN33-14's exposed paddle to the ground plane.

Table 1 lists the output voltage options for the 6 LDO regulators (LDO1 ~ LDO6).

Part Number	Output Voltage Options					
	V _{O1} (V)	V _{O2} (V)	V _{O3} (V)	V _{O4} (V)	V _{O5} (V)	V _{O6} (V)
AAT2606IWO-1-T1	1.8	2.7	3.0	1.8	2.8	1.0
AAT2606IWO-4-T1	3.3	3.3	3.3	3.3	3.3	3.3

Table 1: Output Voltage Options.

AAT2606

Six-Channel 300mA LDO Regulator

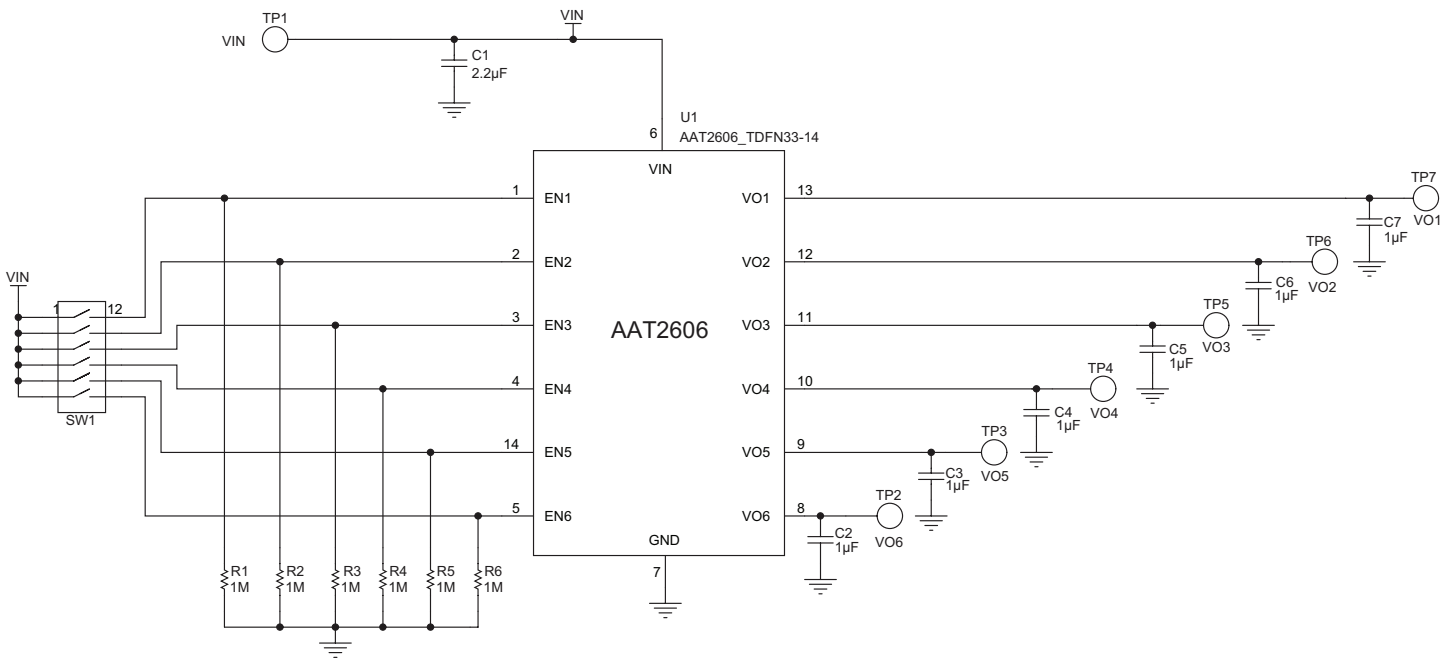

Figure 1: AAT2606 Evaluation Board Schematic.

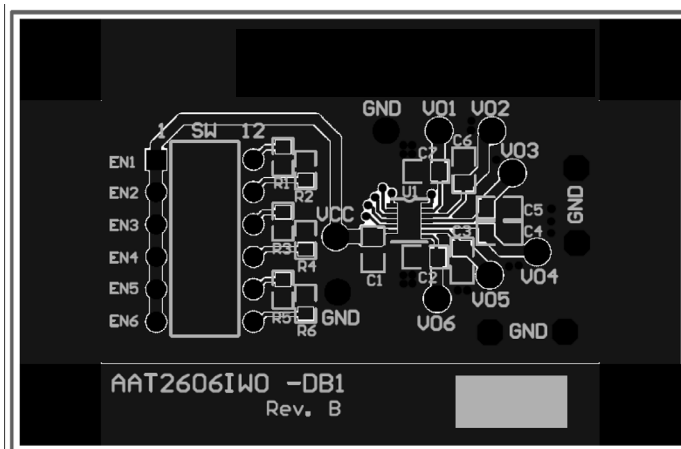

Figure 2: AAT2606 Evaluation Board Top Side Layout.

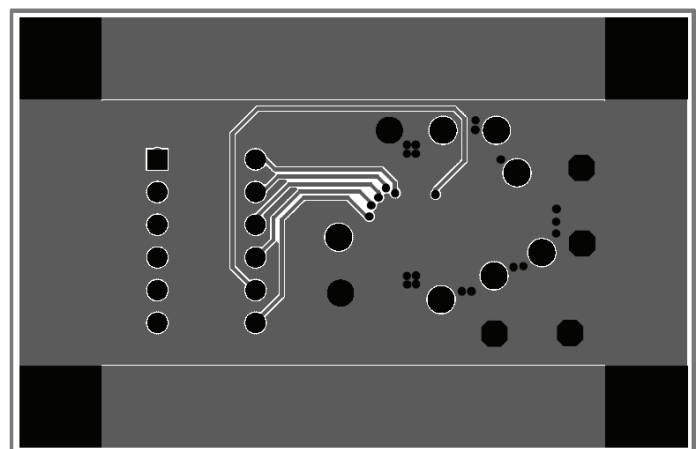

Figure 3: AAT2606 Evaluation Board Bottom Side Layout.

AAT2606

Six-Channel 300mA LDO Regulator

Ordering Information

Package	Marking ¹	Part Number (Tape and Reel) ²
TDFN33-14	9WXY	AAT2606IWO-1-T1
TDFN33-14	X9XY	AAT2606IWO-4-T1



Skyworks Green™ products are compliant with all applicable legislation and are halogen-free.

For additional information, refer to *Skyworks Definition of Green™*, document number SQ04-0074.

Package Information

TDFN33-14³

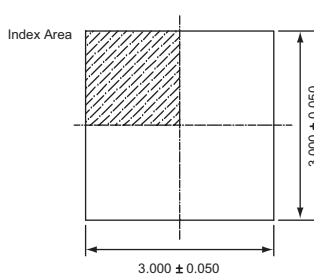

Top View

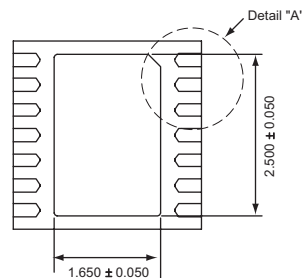

Bottom View

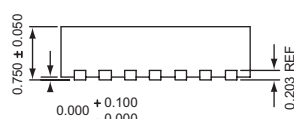

Side View

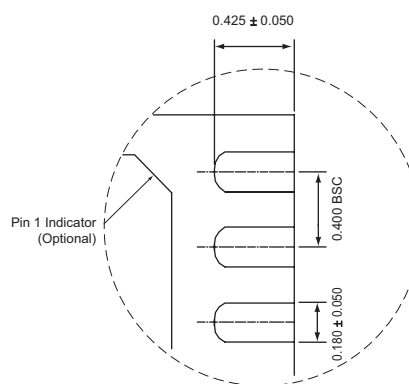

Detail "A"

All dimensions in millimeters.

1. XYY = assembly and date code.
 2. Sample stock is generally held on part numbers listed in **BOLD**.
 3. The leadless package family, which includes QFN, TQFN, DFN, TDFN and STDFN, has exposed copper (unplated) at the end of the lead terminals due to the manufacturing process. A solder fillet at the exposed copper edge cannot be guaranteed and is not required to ensure a proper bottom solder connection.

Copyright © 2012 Skyworks Solutions, Inc. All Rights Reserved.

Information in this document is provided in connection with Skyworks Solutions, Inc. ("Skyworks") products or services. These materials, including the information contained herein, are provided by Skyworks as a service to its customers and may be used for informational purposes only by the customer. Skyworks assumes no responsibility for errors or omissions in these materials or the information contained herein. Skyworks may change its documentation, products, services, specifications or product descriptions at any time, without notice. Skyworks makes no commitment to update the materials or information and shall have no responsibility whatsoever for conflicts, incompatibilities, or other difficulties arising from any future changes.

No license, whether express, implied, by estoppel or otherwise, is granted to any intellectual property rights by this document. Skyworks assumes no liability for any materials, products or information provided hereunder, including the sale, distribution, reproduction or use of Skyworks products, information or materials, except as may be provided in Skyworks Terms and Conditions of Sale.

THE MATERIALS, PRODUCTS AND INFORMATION ARE PROVIDED "AS IS" WITHOUT WARRANTY OF ANY KIND, WHETHER EXPRESS, IMPLIED, STATUTORY, OR OTHERWISE, INCLUDING FITNESS FOR A PARTICULAR PURPOSE OR USE, MERCHANTABILITY, PERFORMANCE, QUALITY OR NON-INFRINGEMENT OF ANY INTELLECTUAL PROPERTY RIGHT; ALL SUCH WARRANTIES ARE HEREBY EXPRESSLY DISCLAIMED. SKYWORKS DOES NOT WARRANT THE ACCURACY OR COMPLETENESS OF THE INFORMATION, TEXT, GRAPHICS OR OTHER ITEMS CONTAINED WITHIN THESE MATERIALS. SKYWORKS SHALL NOT BE LIABLE FOR ANY DAMAGES, INCLUDING BUT NOT LIMITED TO ANY SPECIAL, INDIRECT, INCIDENTAL, STATUTORY, OR CONSEQUENTIAL DAMAGES, INCLUDING WITHOUT LIMITATION, LOST REVENUES OR LOST PROFITS THAT MAY RESULT FROM THE USE OF THE MATERIALS OR INFORMATION, WHETHER OR NOT THE RECIPIENT OF MATERIALS HAS BEEN ADVISED OF THE POSSIBILITY OF SUCH DAMAGE.



Skyworks products are not intended for use in medical, lifesaving or life-sustaining applications, or other equipment in which the failure of the Skyworks products could lead to personal injury, death, physical or environmental damage. Skyworks customers using or selling Skyworks products for use in such applications do so at their own risk and agree to fully indemnify Skyworks for any damages resulting from such improper use or sale.

Customers are responsible for their products and applications using Skyworks products, which may deviate from published specifications as a result of design defects, errors, or operation of products outside of published parameters or design specifications. Customers should include design and operating safeguards to minimize these and other risks. Skyworks assumes no liability for applications assistance, customer product design, or damage to any equipment resulting from the use of Skyworks products outside of stated published specifications or parameters.

Skyworks, the Skyworks symbol, and "Breakthrough Simplicity" are trademarks or registered trademarks of Skyworks Solutions, Inc., in the United States and other countries. Third-party brands and names are for identification purposes only, and are the property of their respective owners. Additional information, including relevant terms and conditions, posted at www.skyworksinc.com, are incorporated by reference.

Looking for pricing, stock, or lifecycle information?

Click below to explore more details on WIN SOURCE:

-  [View AAT2606IWO-1-T1 on WIN SOURCE](#)
-  [Skyworks Solutions Inc. Information](#)

Optimize Your Supply Chain with WIN SOURCE Solutions

-  Global Sourcing Solution
-  Obsolete Management
-  Cost Control Management
-  Shortage Management
-  Alternative Solution
-  Excess Inventory Management