



**THE DATASHEET OF
ZNBG3118JA16TC**



ZNBG3118
LNA GaAs FET BIAS CONTROLLER WITH POLARIZATION AND BAND SELECT

NEW PRODUCT

Summary

The ZNBG3118 is a bias and control solution designed for Satellite Low Noise Blocks (LNB's). Providing three bias stages to power control and protect the GaAs or HEMT FET low noise amplifier's (LNA's). The ZNBG3118 integrates an accurate voltage detector to select the LNB polarisation channel and an advanced tone detector to select the local oscillator (LO) for band switching.

Features

- Provides bias for up to three GaAs and HEMT FETs
- Dynamic FET protection and temperature compensation
- Drain current set by external resistor
- Regulated negative rail generator requires only 2 external capacitors
- Accurate voltage detector and polarisation switch for LNB's
- 22kHz tone detection for band switching with rejection of unwanted signals
- Band switch supports both Discrete, MIMIC and PLL local oscillators
- Compliant with ASTRA control specifications
- Low current for power efficient systems
- Wide operating supply range of 3.3V to 8V

Pin Assignments

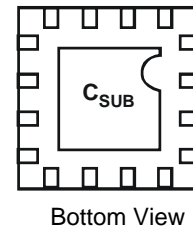
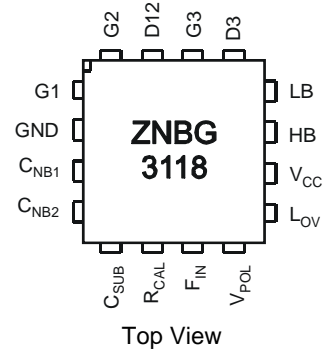

Application

- Single Output LNB's
- Two single type twin LNB's
- Low power LNB's
- PLL Single LNB's

Single Universal LNB System Diagram

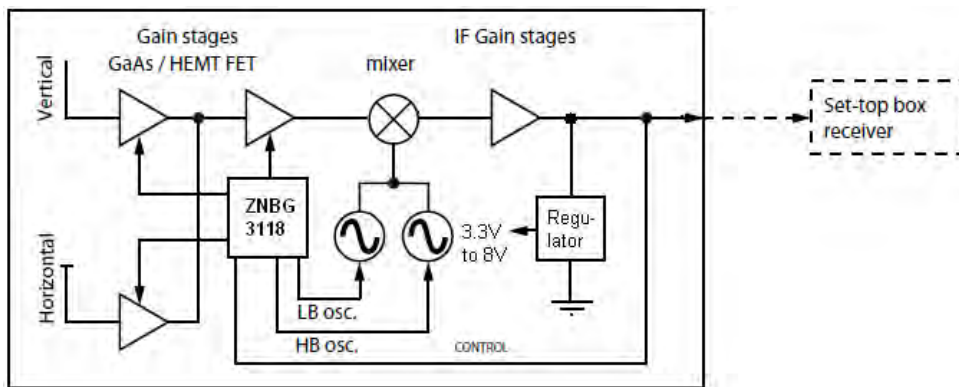

Device Description

The ZNBG series of devices are designed to meet the bias requirements of GaAs and HEMT FETs commonly used in satellite receiver LNBS with a minimum of external components.

With the addition of two capacitors and a resistor the devices provide drain voltage and current control for three external grounded source FETs, generating the regulated negative rail required for FET gate biasing whilst operating from a single supply. This negative bias, at -2.5 volts, can also be used to supply other external circuits.

The ZNBG3118 includes bias circuits to drive up to three external FETs. The voltage applied to the V_{POL} pin determines which one of first two FETs is operational, the third FET is permanently active. This feature is normally used as an LNB polarisation switch to select the required polarisation. Specific to Universal LNB applications is the oscillator band select. This is achieved by detecting a 22kHz tone which enables or disables the relevant local oscillator. The ZNBG3118 has been designed to control various oscillators and down converter designs including Discrete (Bi-polar or MOSFET), MIMIC oscillators and IF amplifier / down-converters IC's with logic enabled phase lock loop (PLL) oscillators.

The ZNBG3118 has been designed to cope with DiSEqC™ ready set top boxes and rejects transients from channel switching.

Drain current setting of the ZNBG3118 is user selectable over the range 0 to 15mA, achieved with addition of a single resistor. The drain voltage for all the FET's is set internally to 2 volts. To minimise the pin out and package size FET 1 and FET 2 share a common drain pin.

These devices are unconditionally stable over the full working temperature with the FETs in place, subject to the inclusion of the recommended gate and drain capacitors. These ensure RF stability and minimal injected noise.

It is possible to use less than the devices full complement of FET bias controls, unused drain and gate connections can be left open circuit without affecting operation of the remaining bias circuits.

To protect the external FETs the circuits have been designed to ensure that, under any conditions including power up/down transients, the gate drive from the bias circuits cannot exceed -3V. Additionally each stage has its own individual current limiter. Furthermore if the negative rail experiences a fault condition, such as overload or short circuit, the drain supply to the FETs will shut down avoiding excessive current flow.

To minimise PCB space ZNBG3118 is packaged in the 16 pin 3mm x 3mm QFN package.

Device operating temperature is -40 to 85°C to suit a wide range of environmental conditions.

Maximum Ratings

Parameter	Rating	Unit
Supply Voltage	-0.6 to +12	V
Supply Current	100	mA
Power Dissipation	500	mW
VPOL Input Voltage	25 Continuous	V
Operating Temperature Range	-40 to +85	°C
Storage Temperature Range	-40 to +150	°C

Electrical Characteristics Measured at Tamb = 25°C, Vcc = 5V, Rcal = 39k (setting Id to 10mA) unless otherwise specified.

Parameter	Conditions	Limits			Units
		Min	Typ.	Max	
Supply Voltage Operating Range	+/-5% Supply tolerance permitted	3.3		8.0	V
Supply Current	Id1 = Id2 = Id3 = 0		1.5	2.5	mA
	Id1 = 0, Id2 = Id3 = 10mA, Vpol = 15.5V		22	24	mA
	Id2 = 0, Id1 = Id3 = 10mA, Vpol = 14V		22	24	mA
	Id1 = Id2 = Id3 = 0, Iib = 10mA		12	14	mA
	Id1 = Id2 = Id3 = 0, Ihb = 10mA		12	14	mA
Substrate Voltage	(Internally generated), Isub=0	-3.0	-2.5	-2.0	V
	Isub = -200uA			-2.0	V
Oscillator Freq.		150	270	800	kHz

Vpol Input

Current	Vpol = 14.75V (Applied via a 10k resistor)	30	42	52.5	uA
V Threshold	(Applied via a 10k resistor)	14.0	14.75	15.5	V
Switching Speed				100	us

Gate characteristics

Gate 1 Output					
Voltage Off	Id12 = 0, Vpol = 14V, Ig1 = 0	-3.0	-2.5	-2.0	V
Voltage Low	Id12 = 12mA, Vpol = 15.5V, Ig1 = -10uA	-3.0	-2.5	-2.0	V
Voltage High	Id12 = 8mA, Vpol = 15.5V, Ig1 = 0	0.4	0.75	1.0	V
Gate 2 Output					
Voltage Off	Id12 = 0, Vpol = 15.5V, Ig2 = 0	-3.0	-2.5	-2.0	V
Voltage Low	Id12 = 12mA, Vpol = 14V, Ig2 = -10uA	-3.0	-2.5	-2.0	V
Voltage High	Id12 = 8mA, Vpol = 14V, Ig2 = 0	0.4	0.75	1.0	V
Gate 3 Output					
Voltage Low	Id3 = 12mA, Ig3 = -10uA	-3.0	-2.5	-2.0	V
Voltage High	Id3 = 8mA, Ig3 = 0	0.4	0.75	1.0	V

Drain characteristics

Drain 12 Output					
Voltage High 1	Id12 = 10mA, Vpol = 15.5V	1.8	2.0	2.2	V
Voltage High 2	Id12 = 10mA, Vpol = 14V	1.8	2.0	2.2	V
Drain 3 Output					
Voltage High	Id3 = 10mA	1.8	2.0	2.2	V
Drains 12 and 3					
delta Vd vs Vcc	Vcc = 3.3 to 8V		0.5		%/V
delta Vd vs Tj	Tj = -40 to +85°C		50		ppm
D1,2 and 3					
Current Range	(Set by Rcal)	0		15	mA
Current		8	10	12	mA
delta Id vs Vcc	Vcc = 3.3 to 8V		2.5		%/V
delta Id vs Tj	Tj = -40 to +85°C		0.05		%/°C

Electrical Characteristics (Continued) Measured at Tamb = 25°C, Vcc = 5V, Rcal = 39k (setting Id to 10mA) unless otherwise specified.

Parameter	Conditions	Limits			Units
		Min	Typ.	Max	
Output Noise					
Drain Voltage	Cgate-gnd = 4.7nF, Cdrain-gnd = 10nF			0.02	Vpk-pk
Gate Voltage	ICgate-gnd = 4.7nF, Cdrain-gnd = 10nF			0.005	Vpk-pk

Tone Detector					
Threshold	22kHz sq.wave, trise = tfall = 10us	100	150	300	mV pk-pk
Noise Rejection	Square wave signal, 1Vpk-pk	1.0	5.0		kHz

LO Output Stage					
Lov Voltage Rng.	Note 1	-0.5		Vcc	V
Lov Bias Cur.	Vlov = 0	0	0.25	1.0	uA
I_LB/HB Max	Vlov = -0.5V to Vcc - 1.0V			35	mA
I_LB/HB Max	Vlov = Vcc - 1.0V to Vcc			100	uA
LB Vout Low	Vlov = 0, Il = 0, Rlb-csub = 1MΩ, Tone enabled	-3.0	-2.5	-2.0	V
LB Vout High	Vlov = 0, Il = 10mA, Tone disabled	-0.025	0	0.025	V
HB Vout Low	Vlov = 0, Il = 0, Rhb-csub = 1MΩ, Tone disabled	-3.0	-2.5	-2.0	V
HB Vout High	Vlov = 0, Il = 10mA, Tone enabled	-0.025	0	0.025	V
LB Vout Low	Vlov = 4.0, Il = 0, Rlb-gnd = 1MΩ, Tone enabled	-0.1	0	0.1	V
LB Vout High	Vlov = 4.0, Il = 35mA, Tone disabled	3.9	4.0	4.1	V
HB Vout Low	Vlov = 4.0, Il = 0, Rhb-gnd = 1MΩ, Tone disabled	-0.1	0	0.1	V
HB Vout High	Vlov = 4.0, Il = 35mA, Tone enabled	3.9	4.0	4.1	V
LB Vout Low	Vlov = Vcc, Il = 0, Rlb-gnd = 1MΩ, Tone enabled	-0.1	0	0.1	V
LB Vout High	Vlov = Vcc, Il = 100uA, Tone disabled	Vcc-0.1	Vcc	Vcc+0.1	V
HB Vout Low	Vlov = Vcc, Il = 0, Rhb-gnd = 1MΩ, Tone disabled	-0.1	0	0.1	V
HB Vout High	Vlov = Vcc, Il = 100uA, Tone enabled	Vcc-0.1	Vcc	Vcc+0.1	V

- Notes:
1. V_Lov - V_LB or V_HB should not be allowed to exceed 6.0V. Care should be taken concerning the Off-state voltages of outputs LB and HB if V_Lov is set to greater than 6.0V. Similarly, Vcc - V_LB or V_HB should not be allowed to exceed 8.5V.
 2. ESD sensitive, handling precautions are recommended.

NEW PRODUCT

Typical Characteristics (Measured at $T_{AMB} = 25^{\circ}C$, $V_{CC} = 5V$, $R_{CAL} = 39k$ (setting I_D to 10mA) unless otherwise stated)

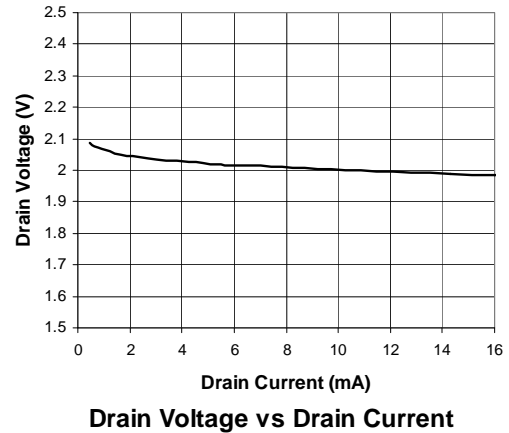
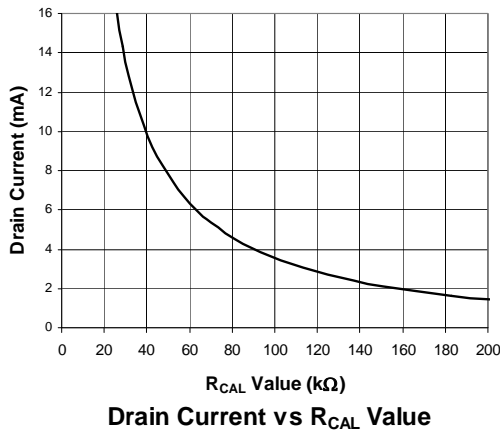

NEW PRODUCT

Single Universal Block Diagram

Figure 1 shows the main elements of a typical single universal LNB. The ZNBG3118 is compliant with virtually all markets including the fleet of Astra satellites. The simple but flexible solution provides the negative rail, FET bias control, polarisation switch control, tone detection and band switching with the minimum of external components. The ZNBG3118 can be also used in other DBS applications such a twin output, mono-block and Low power LNB's.

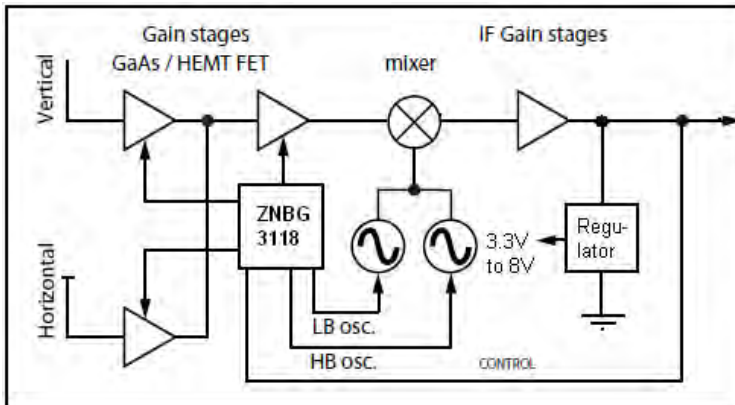

Figure 1 Typical single universal LNB system diagram

Polarization and band switching on the ZNBG3118 uses the standard 13V-17V and 22kHz as defined by Astra. The exception is that the devices voltage detector has a much tighter tolerance than defined to increase field reliability. The tone detector has been designed to cope with distorted 22kHz tones so reliability is maintained with regional differences and variations on set-top box designs.

Tone detection and band switching has been designed to meet various different system architectures. The following diagrams (figures 2 to 4) show how this feature operates in an LNB and the external components required. The presence or absence of a 22kHz tone applied to pin FIN enables one of two outputs, LB and HB. A tone present enables HB and tone absent enables LB. The LB and HB outputs are designed to be compatible with MMIC, Discrete (bipolar or FET) and PLL based local oscillator applications and are easily configured by the LOV pin.

Bi-polar or FET local oscillators

Referring to Figure 2 wiring pin LOV to a positive voltage source (e.g. a potential divider across V_{CC} and ground set to the required oscillator supply voltage, V_{OSC}) will force the LB and HB outputs to provide the required oscillator supply. V_{OSC} when enabled and 0V when disabled. Driving loads of up to 35mA, the maximum allowed programmed output voltage of LB and HB is $V_{CC} .1V$. If a greater supply voltage is required for the oscillators then it may be possible to use an oscillator circuit.

MIMIC local oscillators

Referring to Figure 3 wiring pin LOV to ground will force LB and HB to switch between -2.5V (disabled) and 0V (enabled). Note that $V_{cc(max)}$ should not exceed 6.0V when using this configuration.

Logic enabled PLL local oscillators

Referring to Figure 4 connecting the LOV pin to V_{cc} will pull the LB and HB to V_{cc} when enabled and 0V when disabled. Using the same supply voltage for the ZNBG3118 and the PLL local oscillator block, the LB and HB outputs will provide a suitable logic signal of up to 100uA to drive the LO select pin of a PLL system.

Local Oscillator Configurations

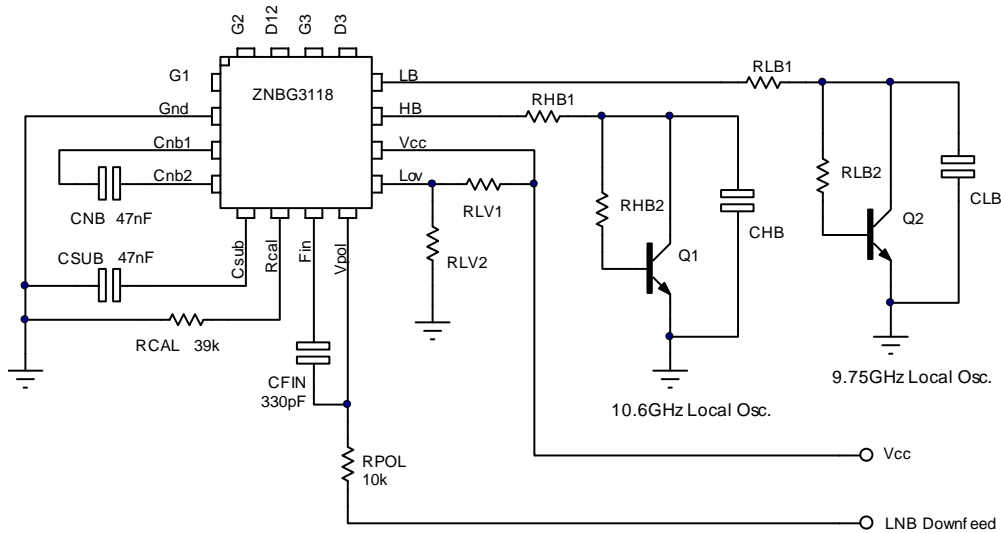

Figure 2 Applications circuit for the ZNBG3118 using Bi-polar oscillators

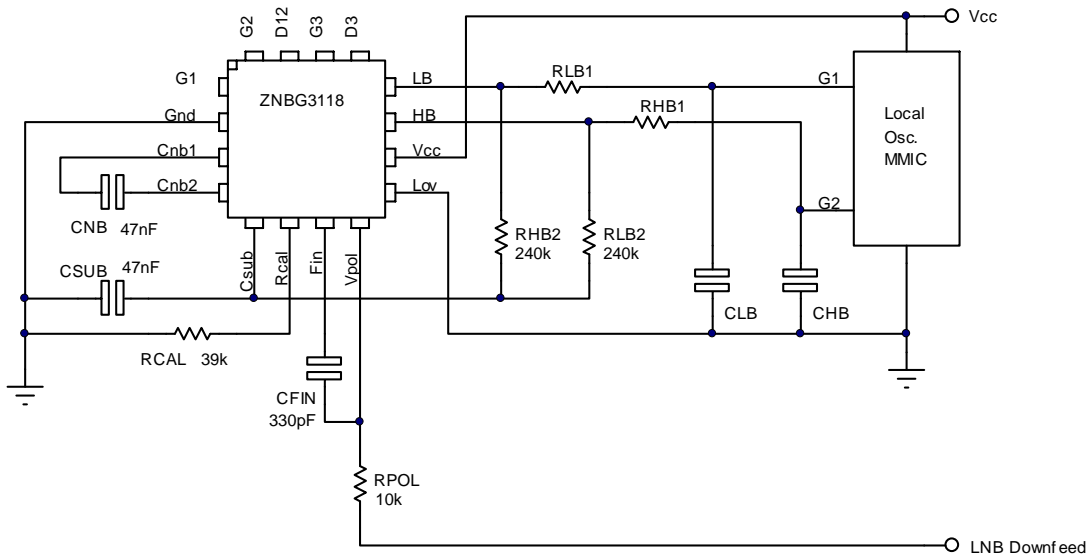

Figure 3 Applications circuit for the ZNBG3118 using MIMIC local oscillators

NEW PRODUCT

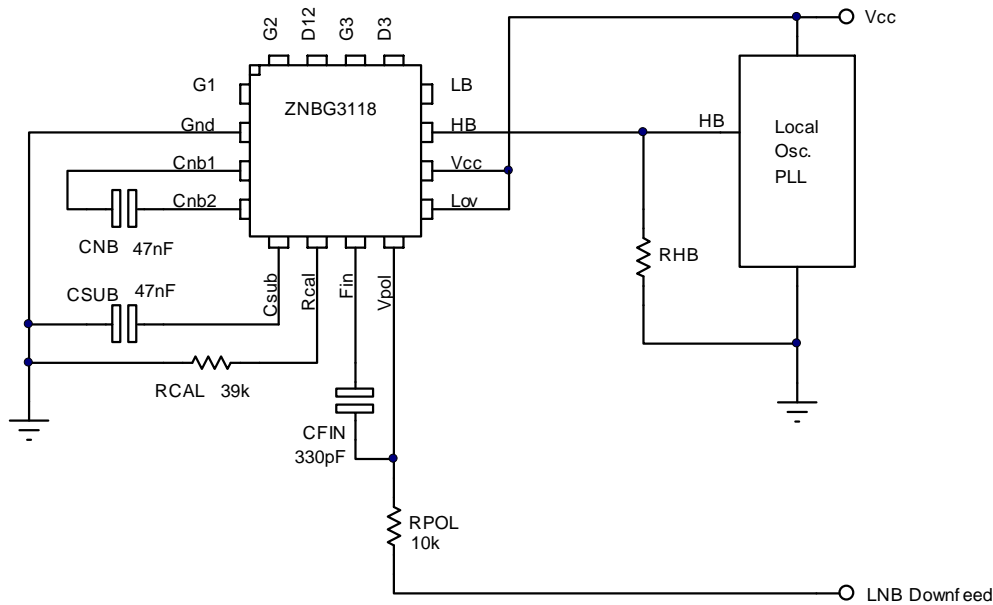

Figure 4 Applications circuit for the ZNBG3118 using logic controlled PLL local oscillators at 3.3V

Functional Tables

ZNBG3118 System Function

Inputs		Outputs				
Vin (V)	Fin (kHz)	FET 1	FET 2	FET 3	LB ⁽¹⁾	HB ⁽¹⁾
<14.0	0	Disabled	Active	Active	Active	Disabled
>15.5	0	Active	Disabled	Active	Active	Disabled
<14.0	22	Disabled	Active	Active	Disabled	Active
>15.5	22	Active	Disabled	Active	Disabled	Active

Note 1: See LO description above and the table below for explanation of Active and Disabled.

Tone Detection Function

Lov	Fin (kHz)	LB	HB	LB	HB
Gnd	0	Enabled	Disabled	Gnd	-2.5V
	22	Disabled	Enabled	-2.5V	Gnd
Vosc	0	Enabled	Disabled	Vosc	Note ⁽²⁾
	22	Disabled	Enabled	Note ⁽²⁾	Vosc
Vcc	0	Enabled	Disabled	Vcc - 0.1V	Note ⁽²⁾
	22	Disabled	Enabled	Note ⁽²⁾	Vcc - 0.1V

Note 2: 0 Volts in a typical LNB application but dependant on the external circuits

Package Outline Dimensions

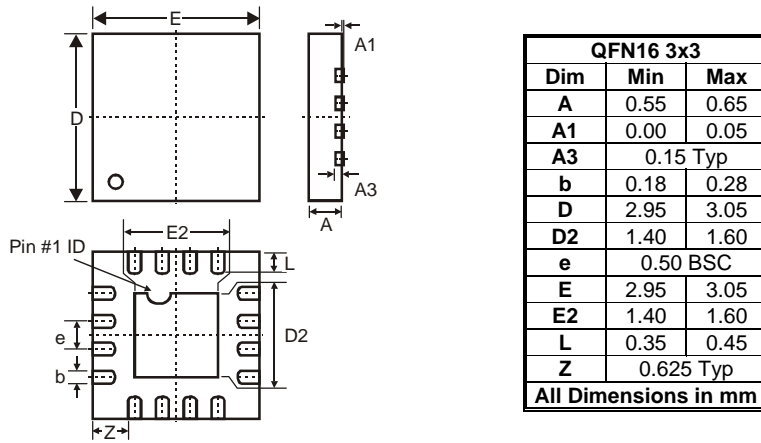

Note: Controlling dimensions are in millimetres. Approximate dimensions are provided in inches.
The package appearance may vary as shown, for further details please contact your local Diodes sales office.

Ordering Information (Note x)

Device	Package	Reel Size (inches)	Tape Width (mm)	Quantity (per reel)
ZNBG3118JA16TC	QFN1633	13	8	3000

Marking Information

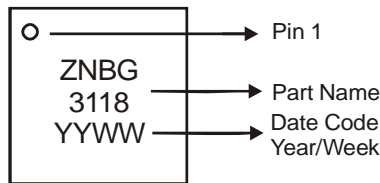

NEW PRODUCT

IMPORTANT NOTICE

DIODES INCORPORATED MAKES NO WARRANTY OF ANY KIND, EXPRESS OR IMPLIED, WITH REGARDS TO THIS DOCUMENT, INCLUDING, BUT NOT LIMITED TO, THE IMPLIED WARRANTIES OF MERCHANTABILITY AND FITNESS FOR A PARTICULAR PURPOSE (AND THEIR EQUIVALENTS UNDER THE LAWS OF ANY JURISDICTION).

Diodes Incorporated and its subsidiaries reserve the right to make modifications, enhancements, improvements, corrections or other changes without further notice to this document and any product described herein. Diodes Incorporated does not assume any liability arising out of the application or use of this document or any product described herein; neither does Diodes Incorporated convey any license under its patent or trademark rights, nor the rights of others. Any Customer or user of this document or products described herein in such applications shall assume all risks of such use and will agree to hold Diodes Incorporated and all the companies whose products are represented on Diodes Incorporated website, harmless against all damages.

Diodes Incorporated does not warrant or accept any liability whatsoever in respect of any products purchased through unauthorized sales channel. Should Customers purchase or use Diodes Incorporated products for any unintended or unauthorized application, Customers shall indemnify and hold Diodes Incorporated and its representatives harmless against all claims, damages, expenses, and attorney fees arising out of, directly or indirectly, any claim of personal injury or death associated with such unintended or unauthorized application.

Products described herein may be covered by one or more United States, international or foreign patents pending. Product names and markings noted herein may also be covered by one or more United States, international or foreign trademarks.

LIFE SUPPORT

Diodes Incorporated products are specifically not authorized for use as critical components in life support devices or systems without the express written approval of the Chief Executive Officer of Diodes Incorporated. As used herein:

- A. Life support devices or systems are devices or systems which:
 - 1. are intended to implant into the body, or
 - 2. support or sustain life and whose failure to perform when properly used in accordance with instructions for use provided in the labeling can be reasonably expected to result in significant injury to the user.
- B. A critical component is any component in a life support device or system whose failure to perform can be reasonably expected to cause the failure of the life support device or to affect its safety or effectiveness.



Customers represent that they have all necessary expertise in the safety and regulatory ramifications of their life support devices or systems, and acknowledge and agree that they are solely responsible for all legal, regulatory and safety-related requirements concerning their products and any use of Diodes Incorporated products in such safety-critical, life support devices or systems, notwithstanding any devices- or systems-related information or support that may be provided by Diodes Incorporated. Further, Customers must fully indemnify Diodes Incorporated and its representatives against any damages arising out of the use of Diodes Incorporated products in such safety-critical, life support devices or systems.

Copyright © 2010, Diodes Incorporated

www.diodes.com

Looking for pricing, stock, or lifecycle information?

Click below to explore more details on WIN SOURCE:

-  [View ZNBG3118JA16TC on WIN SOURCE](#)
-  [Diodes Incorporated Information](#)

Optimize Your Supply Chain with WIN SOURCE Solutions

-  Global Sourcing Solution
-  Obsolete Management
-  Cost Control Management
-  Shortage Management
-  Alternative Solution
-  Excess Inventory Management