



**THE DATASHEET OF  
ZNBG3211Q20TC**



# FET BIAS CONTROLLER WITH POLARISATION SWITCH AND TONE DETECTION

**ZNBG3210**  
**ZNBG3211**

ISSUE 2 - FEBRUARY 2000

## DEVICE DESCRIPTION

The ZNBG series of devices are designed to meet the bias requirements of GaAs and HEMT FETs commonly used in satellite receiver LNBS, PMR cellular telephones etc. with a minimum of external components.

With the addition of two capacitors and a resistor the devices provide drain voltage and current control for three external grounded source FETs, generating the regulated negative rail required for FET gate biasing whilst operating from a single supply. This negative bias, at -3 volts, can also be used to supply other external circuits.

The ZNBG3210/11 includes bias circuits to drive up to three external FETs. A control input to the device selects either one of two FETs as operational using 0V gate switching methodology, the third FET is permanently active. This feature is particularly used as an LNB polarisation switch. Also specific to LNB applications is the enhanced 22kHz tone detection and logic output feature which is used to enable high and low band frequency switching. The detector has been specifically designed to reject interference such as low frequency signals and DiSEqC™ tone bursts - without the use of additional external components.

Drain current setting of the ZNBG3210/11 is user selectable over the range 0 to 15mA, this

is achieved with the addition of a single resistor. The series also offers the choice of FET drain voltage, the 3210 gives 2.2 volts drain whilst the 3211 gives 2 volts.

These devices are unconditionally stable over the full working temperature with the FETs in place, subject to the inclusion of the recommended gate and drain capacitors. These ensure RF stability and minimal injected noise.

It is possible to use less than the devices full complement of FET bias controls, unused drain and gate connections can be left open circuit without affecting operation of the remaining bias circuits.

In order to protect the external FETs the circuits have been designed to ensure that, under any conditions including power up/down transients, the gate drive from the bias circuits cannot exceed the range -3.5V to 1V. Furthermore if the negative rail experiences a fault condition, such as overload or short circuit, the drain supply to the FETs will shut down avoiding excessive current flow.

The ZNBG3210/11 are available in QSOP20 for the minimum in device size. Device operating temperature is -40 to 70°C to suit a wide range of environmental conditions.

## FEATURES

- Provides bias for GaAs and HEMT FETs
- Drives up to three FETs
- Dynamic FET protection
- Drain current set by external resistor
- Regulated negative rail generator requires only 2 external capacitors
- Choice in drain voltage
- Wide supply voltage range
- Polarisation switch for LNBS - supporting zero volt gate switching topology.
- 22kHz tone detection for band switching
- Compliant with ASTRA control specifications
- QSOP surface mount package

## APPLICATIONS

- Satellite receiver LNBS
- Private mobile radio (PMR)
- Cellular telephones

# ZNBG3210

# ZNBG3211

## ABSOLUTE MAXIMUM RATINGS

Supply Voltage	-0.6V to 12V	<b>Power Dissipation (T<sub>amb</sub>= 25°C)</b>	
Supply Current	100mA	QSOP20	500mW
Input Voltage (V <sub>POL</sub> )	25V Continuous		
Drain Current (per FET) (set by R <sub>CAL</sub> )	0 to 15mA		
Operating Temperature	-40 to 70°C		
Storage Temperature	-50 to 85°C		

## ELECTRICAL CHARACTERISTICS. TEST CONDITIONS

(Unless otherwise stated): T<sub>amb</sub>= 25°C, V<sub>CC</sub>=5V, I<sub>D</sub>=10mA (R<sub>CAL</sub>=33kΩ)

SYMBOL	PARAMETER	CONDITIONS	LIMITS			UNITS
			MIN.	TYP.	MAX.	
V <sub>CC</sub>	Supply Voltage		5		10	V
I <sub>CC</sub>	Supply Current	I <sub>D1</sub> to I <sub>D3</sub> =0 I <sub>D1</sub> =0, I <sub>D2</sub> to I <sub>D3</sub> =10mA, V <sub>POL</sub> =14V I <sub>D2</sub> =0, I <sub>D1</sub> to I <sub>D3</sub> =10mA, V <sub>POL</sub> =15.5V I <sub>D1</sub> to I <sub>D3</sub> =0, I <sub>LB</sub> =10mA I <sub>D1</sub> to I <sub>D3</sub> =0, I <sub>HB</sub> =10mA		6 25 25 16 16	15 35 35 25 25	mA mA mA mA mA
V <sub>SUB</sub>	Substrate Voltage	(Internally generated) I <sub>SUB</sub> =0 I <sub>SUB</sub> =-200μA	-3.5	-3.0	-2.5 -2.4	V V
E <sub>ND</sub> E <sub>NG</sub>	Output Noise Drain Voltage Gate Voltage	C <sub>G</sub> =4.7nF, C <sub>D</sub> =10nF C <sub>G</sub> =4.7nF, C <sub>D</sub> =10nF			0.02 0.005	Vpkpk Vpkpk
f <sub>O</sub>	Oscillator Frequency		200	350	800	kHz

# ZNBG3210 ZNBG3211

SYMBOL	PARAMETER	CONDITIONS	LIMITS			UNITS
			MIN.	TYP.	MAX.	

## GATE CHARACTERISTICS

I <sub>GO</sub>	Output Current Range		-30		2000	μA		
		<b>I<sub>Dx</sub></b> (mA)	<b>V<sub>POL</sub></b> (V)	<b>I<sub>GOx</sub></b> (μA)				
V <sub>G10</sub>	Output Voltage Gate 1 Off	I <sub>D1</sub> =0	V <sub>POL</sub> =14	I <sub>GO1</sub> =0	-0.05	0	0.05	V
V <sub>G1L</sub>	Low	I <sub>D1</sub> =12	V <sub>POL</sub> =15.5	I <sub>GO1</sub> =-10	-2.7	-2.4	-2.0	V
V <sub>G1H</sub>	High	I <sub>D1</sub> =8	V <sub>POL</sub> =15.5	I <sub>GO1</sub> =0	0.4	0.75	1.0	V
V <sub>G20</sub>	Output Voltage Gate 2 Off	I <sub>D2</sub> =0	V <sub>POL</sub> =15.5	I <sub>GO2</sub> =0	-0.05	0	0.05	V
V <sub>G2L</sub>	Low	I <sub>D2</sub> =12	V <sub>POL</sub> =14	I <sub>GO2</sub> =-10	-2.7	-2.4	-2.0	V
V <sub>G2H</sub>	High	I <sub>D2</sub> =8	V <sub>POL</sub> =14	I <sub>GO2</sub> =0	0.4	0.75	1.0	V
V <sub>G3L</sub>	Output Voltage Gate 3 Low	I <sub>D3</sub> =12		I <sub>GO3</sub> =-10	-3.5	-2.9	-2.0	V
V <sub>G3H</sub>	High	I <sub>D3</sub> =8		I <sub>GO3</sub> =0	0.4	0.75	1.0	V

## DRAIN CHARACTERISTICS

I <sub>D</sub>	Current		8	10	12	mA
ΔI <sub>DV</sub> ΔI <sub>DT</sub>	Current Change with V <sub>CC</sub> with T <sub>j</sub>	V <sub>CC</sub> = 5 to 10V T <sub>j</sub> =-40 to +70°C		0.5 0.05		%/V %/°C
V <sub>D1</sub>	Drain 1 Voltage: High					
	ZNBG3210	I <sub>D1</sub> =10mA, V <sub>POL</sub> =15.5V	2.0	2.2	2.4	V
	ZNBG3211	I <sub>D1</sub> =10mA, V <sub>POL</sub> =15.5V	1.8	2.0	2.2	V
V <sub>D2</sub>	Drain 2 Voltage: High					
	ZNBG3210	I <sub>D2</sub> =10mA, V <sub>POL</sub> =14V	2.0	2.2	2.4	V
	ZNBG3211	I <sub>D2</sub> =10mA, V <sub>POL</sub> =14V	1.8	2.0	2.2	V
V <sub>D3</sub>	Drain 3 Voltage: High					
	ZNBG3210	I <sub>D3</sub> =10mA	2.0	2.2	2.4	V
	ZNBG3211	I <sub>D3</sub> =10mA	1.8	2.0	2.2	V
ΔV <sub>DV</sub> ΔV <sub>DT</sub>	Voltage Change with V <sub>CC</sub> with T <sub>j</sub>	V <sub>CC</sub> = 5 to 10V T <sub>j</sub> =-40 to +70°C		0.5 50		%/V ppm
I <sub>L1</sub> I <sub>L2</sub>	Leakage Current Drain 1 Drain 2	V <sub>D1</sub> =0.5V, V <sub>POL</sub> =14V V <sub>D2</sub> =0.5V, V <sub>POL</sub> =15.5V			10 10	μA μA

# ZNBG3210

# ZNBG3211

SYMBOL	PARAMETER	CONDITIONS	LIMITS			UNITS
			MIN.	TYP.	MAX.	

## tone detection characteristics

$I_B$	<b>Filter Amplifier</b> Input Bias Current	$R_{F1}=150k\Omega$	0.02	0.07	0.25	$\mu A$
$V_{OUT}$	Output Voltage <sup>5</sup>	$R_{F1}=150k\Omega$	1.75	1.95	2.05	V
$I_{OUT}$	Output Current <sup>5</sup>	$V_{OUT}=1.96V, V_{FIN}=2.1V$	400	520	650	$\mu A$
$G_V$	Voltage Gain	$f=22kHz, V_{IN}=1mV$		46		dB
$f_R^8$	Rejection Frequency	$V_{(AC)in}=1V$ p/p sq.w <sup>6</sup>	1.0	7.5		kHz
$V_{LOV}$	<b>Output Stage</b> $L_{OV}$ Volt. Range	$I_L=50mA(L_B \text{ or } H_B)$	-0.5		$V_{CC}-1.8$	V
$I_{LOV}$	$L_{OV}$ Bias Current	$V_{LOV}=0$	0.02	0.15	1.0	$\mu A$
$V_{LBL}$	$L_B$ Output Low	$V_{LOV}=0$ $I_L=-10\mu A$ Enabled <sup>6</sup> $V_{LOV}=3V$ $I_L=0$ Enabled <sup>7</sup>	-3.5 -0.01	-2.75 0	-2.5 0.01	V V
$V_{LBH}$	$L_B$ Output High	$V_{LOV}=0$ $I_L=10mA$ Disabled <sup>6</sup> $V_{LOV}=3V$ $I_L=50mA$ Disabled <sup>7</sup>	-0.025 2.9	0 3.0	0.025 3.1	V V
$V_{HBL}$	$H_B$ Output Low	$V_{LOV}=0$ $I_L=-10\mu A$ Disabled <sup>6</sup> $V_{LOV}=3V$ $I_L=0$ Disabled <sup>7</sup>	-3.5 -0.01	-2.75 0	-2.5 0.01	V V
$V_{HBH}$	$H_B$ Output High	$V_{LOV}=0$ $I_L=10mA$ Enabled <sup>6</sup> $V_{LOV}=3V$ $I_L=50mA$ Enabled <sup>7</sup>	-0.025 2.9	0 3.0	0.025 3.1	V V

## Polarity Switch Characteristics

$I_{POL}$	Input Current	$V_{POL}=25V$ (Applied via $R_{POL}=10k\Omega$ )	10	20	40	$\mu A$
$V_{TPOL}$	Threshold Voltage	$V_{POL}=25V$ (Applied via $R_{POL}=10k\Omega$ )	14	14.75	15.5	V
$T_{SPOL}$	Switching Speed	$V_{POL}=25V$ (Applied via $R_{POL}=10k\Omega$ )			100	ms

### NOTES:

1. The negative bias voltages specified are generated on-chip using an internal oscillator. Two external capacitors,  $C_{NB}$  and  $C_{SUB}$ , of 47nF are required for this purpose.
2. The characteristics are measured using an external reference resistor  $R_{CAL}$  of value 33k wired from pins  $R_{CAL}$  to ground.
3. Noise voltage is not measured in production.
4. Noise voltage measurement is made with FETs and gate and drain capacitors in place on all outputs.  $C_G$ , 4.7nF, are connected between gate outputs and ground,  $C_D$ , 10nF, are connected between drain outputs and ground.
5. These parameters are linearly related to  $V_{CC}$ .
6. These parameters are measured using Test Circuit 1
7. These parameters are measured using Test Circuit 2
8. The ZNBG32 series will also reject DiSEqC™ and other common switching bursts.

# ZNBG3210 ZNBG3211

## TEST CIRCUIT 1

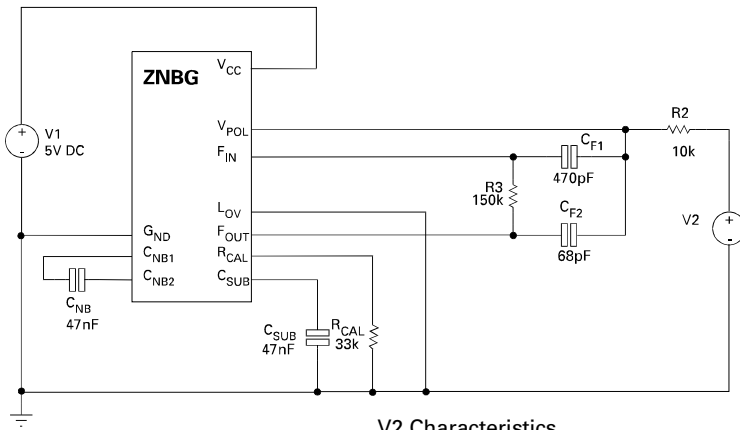

### V2 Characteristics

Type AC source  
 Frequency 22kHz  
 Voltage 350mV p/p enabled  
 100mV p/p disabled

## TEST CIRCUIT 2

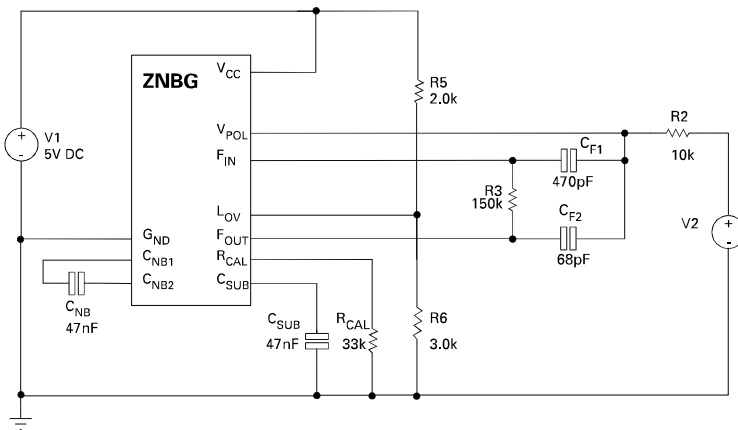

### V2 Characteristics

Type AC source  
 Frequency 22kHz  
 Voltage 350mV p/p enabled  
 100mV p/p disabled

# ZNBG3210 ZNBG3211

## TYPICAL CHARACTERISTICS

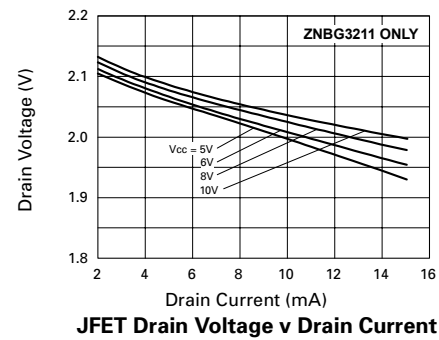
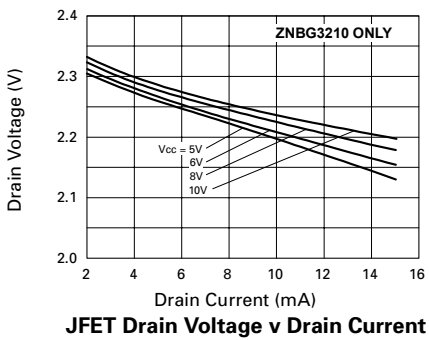
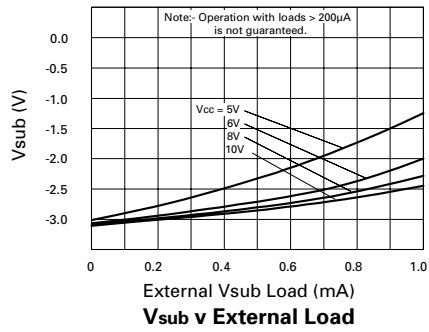
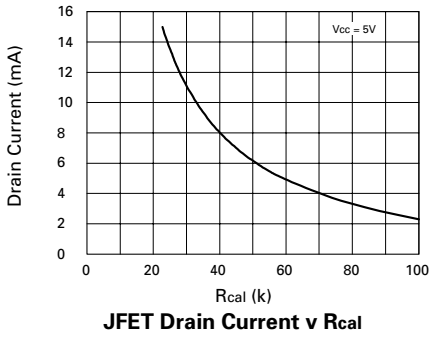

# ZNBG3210 ZNBG3211

## TYPICAL CHARACTERISTICS

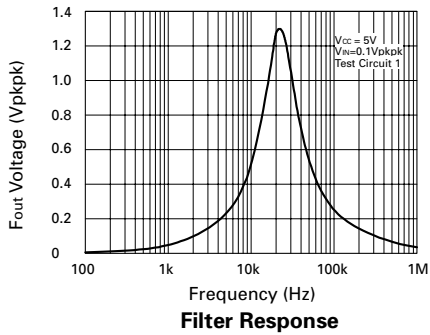
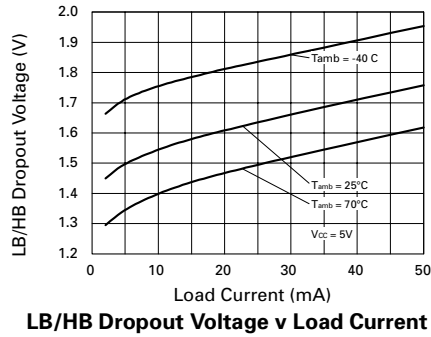
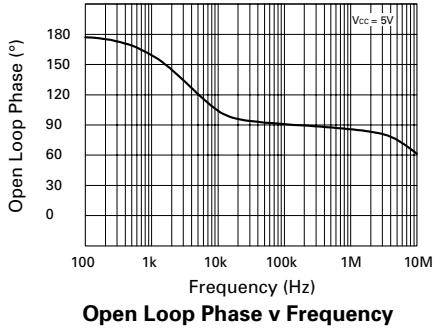
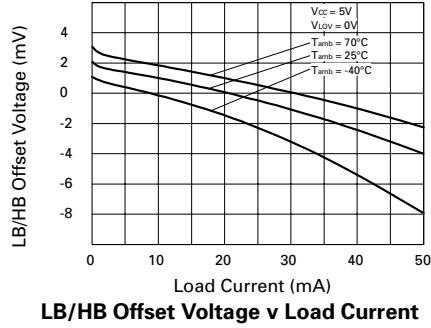
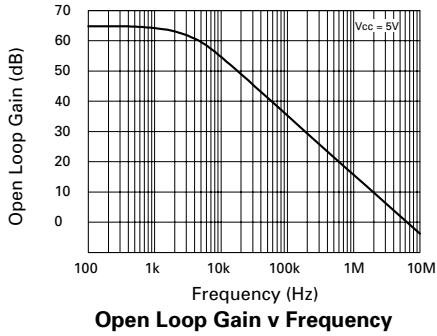

# ZNBG3210 ZNBG3211

## FUNCTIONAL DIAGRAM

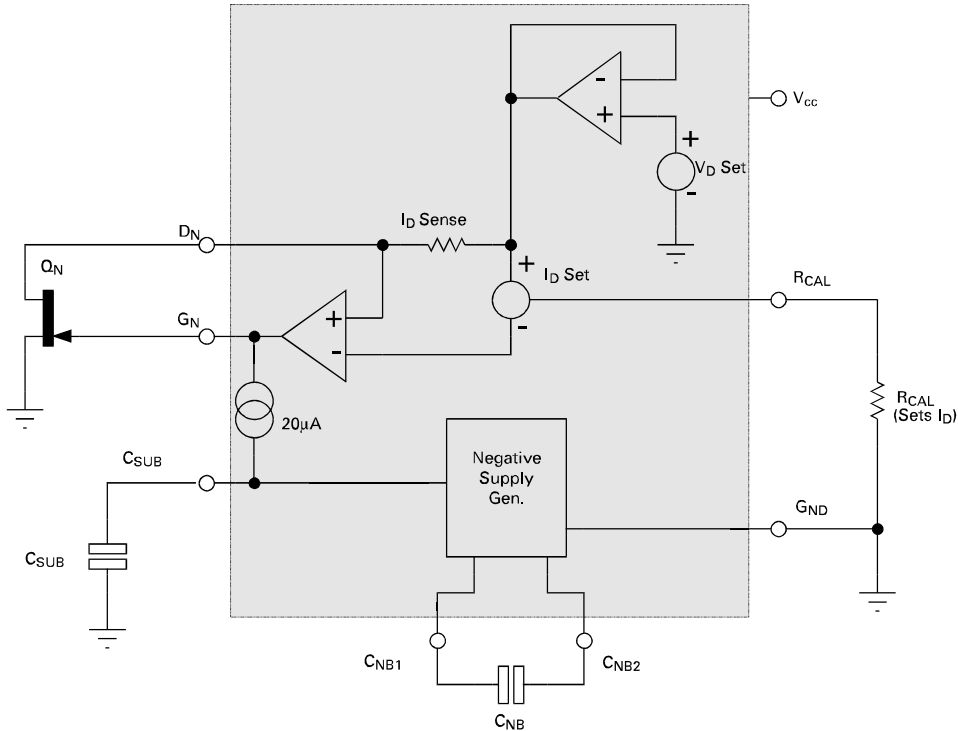

## FUNCTIONAL DESCRIPTION

The ZNBG devices provide all the bias requirements for external FETs, including the generation of the negative supply required for gate biasing, from the single supply voltage. The diagram above shows a single stage from the ZNBG series. The ZNBG3210/11 contains 3 such stages. The negative rail generator is common to all devices.

The drain voltage of the external FET  $Q_N$  is set by the ZNBG device to its normal operating voltage. This is determined by the on board  $V_D$  Set reference, for the ZNBG3210 this is nominally 2.2 volts whilst the ZNBG3211 provides nominally 2 volts.

The drain current taken by the FET is monitored by the low value resistor  $I_D$  Sense. The amplifier driving the gate of the FET adjusts the gate voltage of  $Q_N$  so that the drain current taken matches the current called for by an external resistor  $R_{CAL}$ .

Since the FET is a depletion mode transistor, it is often necessary to drive its gate negative with respect to ground to obtain the required drain current. To provide this capability powered from a single positive supply, the device includes a low current negative supply generator. This generator uses an internal oscillator and two external capacitors,  $C_{NB}$  and  $C_{SUB}$ .

# ZNBG3210 ZNBG3211

The following schematic shows the function of the  $V_{POL}$  input. Only one of the two external FETs numbered Q1 and Q2 are powered at any one time, their selection is controlled by the input  $V_{POL}$ . This input is designed to be wired to the power input of the LNB via a high value (10k) resistor. With the input voltage of the LNB set at or below 14V, FET Q2 will be enabled. With the input voltage at or above 15.5V, FET Q1 will be enabled. The disabled FET has its gate driven to 0V and its drain terminal is switched open circuit. FET number Q3 is always active regardless of the voltage applied to  $V_{POL}$ .

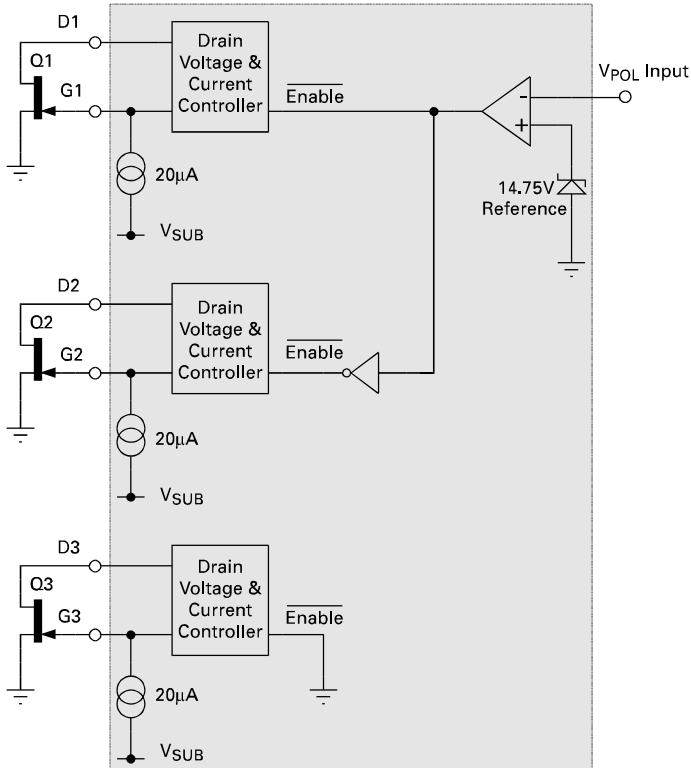

## Control Input Switch Function

Input Sense	Polarisation	Select
$\lll 14$ volts	Vertical	FET Q2
$\geq 15.5$ volts	Horizontal	FET Q1

# ZNBG3210 ZNBG3211

For many LNB applications tone detection and band switching is required. The ZNBG3210/11 includes the circuitry necessary to detect the presence of a 22kHz tone modulated on the supply input to the LNB. Referring to the following schematic diagram, the main elements of this detector are an op-amp enabling the construction of a Sallen Key filter, a rectifier/smoother and a comparator. Full control is given over the centre frequency and bandwidth of the filter by the selection of two external resistors and capacitors (one of these resistors, R2, shares the function of overvoltage protection of pin  $V_{POL}$ ). The detector used in the ZNBG32 series has been specifically designed to reject low frequency signals, DiSeqC™ tone bursts and other common interference signals that may be present on the LNB supply input. This has been achieved without the need for any additional external components.

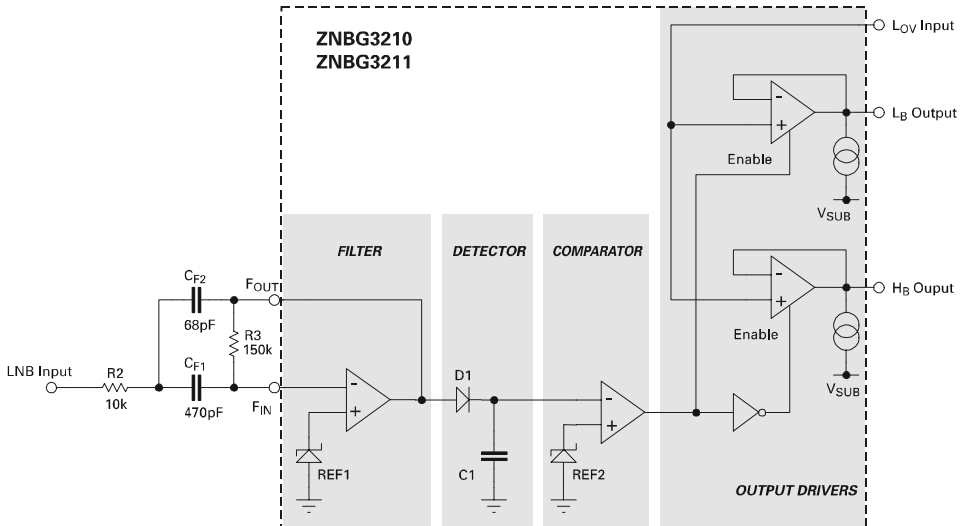

# ZNBG3210 ZNBG3211

## APPLICATIONS CIRCUIT

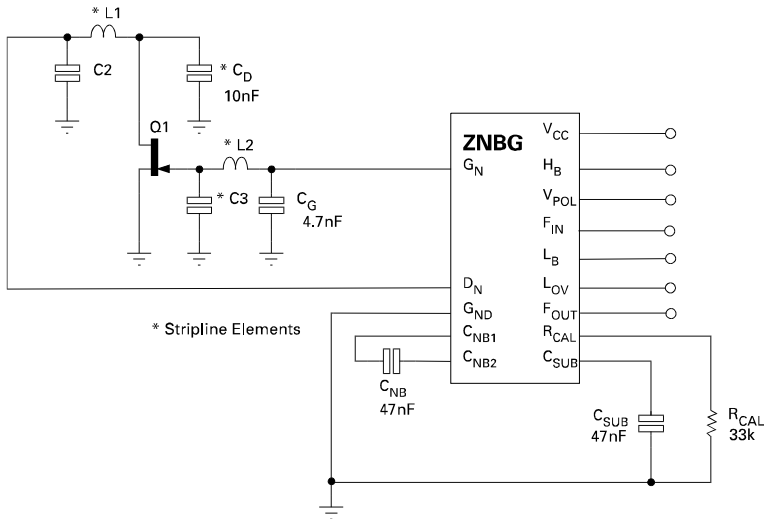

## APPLICATIONS INFORMATION

The above is a partial application circuit for the ZNBG series showing all external components required for appropriate biasing. The bias circuits are unconditionally stable over the full temperature range with the associated FETs and gate and drain capacitors in circuit.

Capacitors  $C_D$  and  $C_G$  ensure that residual power supply and substrate generator noise is not allowed to affect other external circuits which may be sensitive to RF interference. They also serve to suppress any potential RF feedthrough between stages via the ZNBG device. These capacitors are required for all stages used. Values of 10nF and 4.7nF respectively are recommended however this is design dependent and any value between 1nF and 100nF could be used.

The capacitors  $C_{NB}$  and  $C_{SUB}$  are an integral part of the ZNBGs negative supply generator. The negative bias voltage is generated on-chip using an internal oscillator. The required value of capacitors  $C_{NB}$  and  $C_{SUB}$  is 47nF. This generator produces a low current supply of approximately -3 volts. Although this generator is intended purely to bias the external FETs, it can be used to power other external circuits via the  $C_{SUB}$  pin.

Resistor  $R_{CAL}$  sets the drain current at which all external FETs are operated. If any bias control circuit is not required, its related drain and gate connections may be left open circuit without affecting the operation of the remaining bias circuits.

The ZNBG devices have been designed to protect the external FETs from adverse operating conditions. With a JFET connected to any bias circuit, the gate output voltage of the bias circuit can not exceed the range -3.5V to 1V under any conditions, including powerup and powerdown transients. Should the negative bias generator be shorted or overloaded so that the drain current of the external FETs can no longer be controlled, the drain supply to FETs is shut down to avoid damage to the FETs by excessive drain current.

# ZNBG3210 ZNBG3211

The following block diagram shows the main section of an LNB designed for use with the Astra series of satellites. The ZNBG3210/11 is the core bias and control element of this circuit. The ZNBG provides the negative rail, FET bias control, polarisation switch control, tone detection and band switching with the minimum of external components. Compared to other discrete component solutions the ZNBG circuit reduces component count and overall size required.

## Single Universal LNB Block Diagram

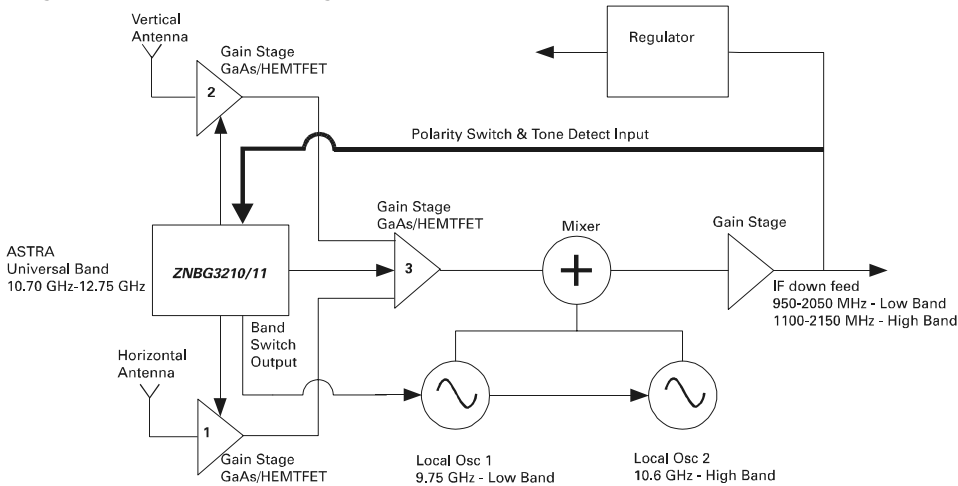

Tone detection and band switching is provided on the ZNBG3210/11 devices. The following diagrams describes how this feature operates in an LNB and the external components required. The presence or absence of a 22kHz tone applied to pin  $F_{IN}$  enables one of two outputs,  $L_B$  and  $H_B$ . A tone present enables  $H_B$  and tone absent enables  $L_B$ . The  $L_B$  and  $H_B$  outputs are designed to be compatible with both MMIC and discrete local oscillator applications, selected by pin  $L_{OV}$ . Referring to Figure 1 wiring pin  $L_{OV}$  to ground will force  $L_B$  and  $H_B$  to switch between -2.6V (disabled) and 0V (enabled). Referring to Figure 2 wiring pin  $L_{OV}$  to a positive voltage source (e.g. a potential divider across  $V_{CC}$  and ground set to the required oscillator supply voltage,  $V_{OSC}$ ) will force the  $L_B$  and  $H_B$  outputs to provide the required oscillator supply,  $V_{OSC}$ , when enabled.

## Tone Detection Function

$L_{OV}$	$F_{IN}$	$L_B$	$H_B$	$L_B$	$H_B$
$G_{ND}$	22kHz	Disabled	Enabled	-2.6 volts	$G_{ND}$
	—	Enabled	Disabled	$G_{ND}$	-2.6 volts
$V_{OSC}$	22kHz	Disabled	Enabled	Note 1	$V_{OSC}$
	—	Enabled	Disabled	$V_{OSC}$	Note 1

Note 1: 0 volts in typical LNB applications but dependent on external circuits.

# ZNBG3210 ZNBG3211

## APPLICATIONS INFORMATION(cont)

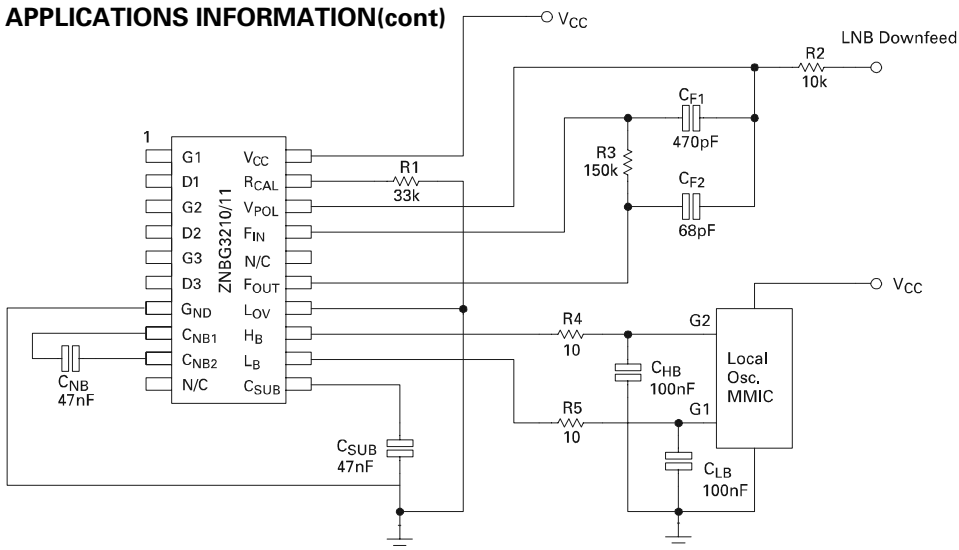

Figure 1  
Lov grounded

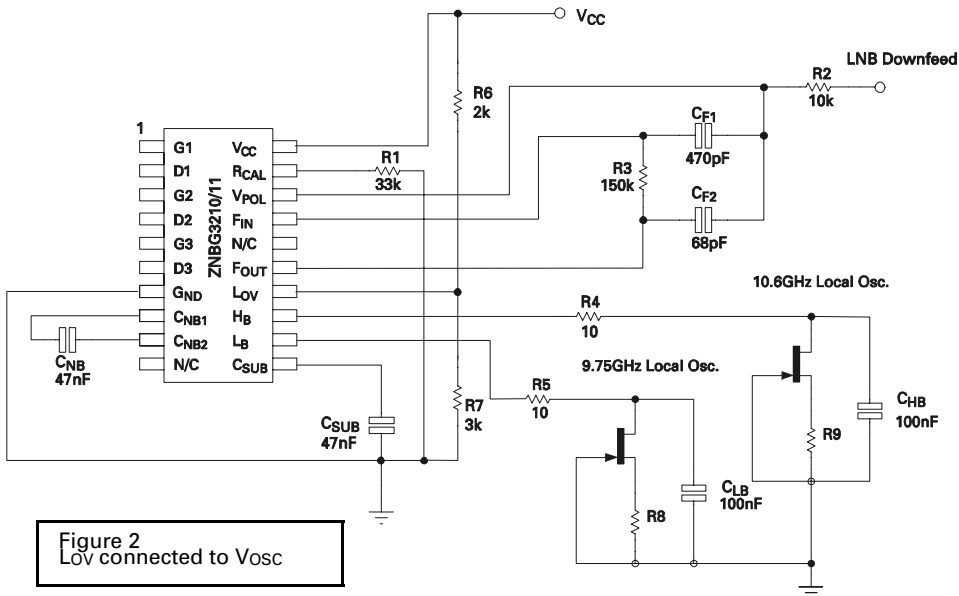
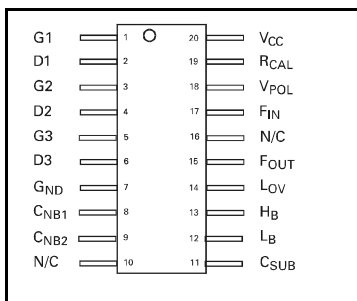

Figure 2  
Lov connected to Vosc

# ZNBG3210

# ZNBG3211

## CONNECTION DIAGRAM



## ORDERING INFORMATION

Part Number	Package	Part Mark
ZNBG3210Q20	QSOP20	ZNBG3210
ZNBG3211Q20	QSOP20	ZNBG3211

# ZNBG3210 ZNBG3211

## PACKAGE DIMENSIONS

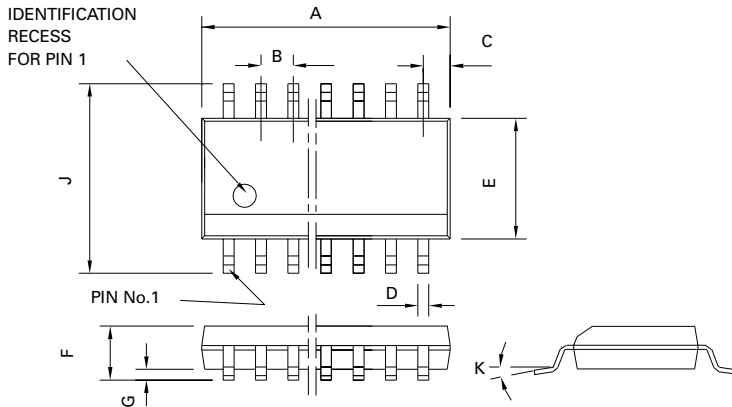

PIN	Millimetres		Inches	
	MIN	MAX	MIN	MAX
A	8.55	8.74	0.337	0.344
B	0.635		0.025 NOM	
C	1.42	1.52	0.056	0.06
D	0.20	0.30	0.008	0.012
E	3.81	3.99	0.15	0.157
F	1.35	1.75	0.053	0.069
G	0.10	0.25	0.004	0.01
J	5.79	6.20	0.228	0.244
K	0°	8°	0°	8°

# ZETEX

Zetex plc.  
Fields New Road, Chadderton, Oldham, OL9-8NP, United Kingdom.  
Telephone: (44)161 622 4422 (Sales), (44)161 622 4444 (General Enquiries)  
Fax: (44)161 622 4420

Zetex GmbH  
Streitfeldstraße 19  
D-81673 München  
Germany  
Telefon: (49) 89 45 49 49 0  
Fax: (49) 89 45 49 49 49

Zetex Inc.  
47 Mall Drive, Unit 4  
Commack NY 11725  
USA  
Telephone: (631) 543-7100  
Fax: (631) 864-7630

Zetex (Asia) Ltd.  
3701-04 Metroplaza, Tower 1  
Hing Fong Road,  
Kwai Fong, Hong Kong  
Telephone: (852) 26100 611  
Fax: (852) 24250 494

These are supported by  
agents and distributors in  
major countries world-wide  
©Zetex plc 2001

<http://www.zetex.com>

This publication is issued to provide outline information only which (unless agreed by the Company in writing) may not be used, applied or reproduced for any purpose or form part of any order or contract or be regarded as a representation relating to the products or services concerned. The Company reserves the right to alter without notice the specification, design, price or conditions of supply of any product or service.



DiSEqC is a trademark of EUTELSAT

**ZNBG3210**  
**ZNBG3211**







This page intentionally left blank

## Looking for pricing, stock, or lifecycle information?

Click below to explore more details on WIN SOURCE:

-  [View ZNBG3211Q20TC on WIN SOURCE](#)
-  [Diodes Incorporated Information](#)

## Optimize Your Supply Chain with WIN SOURCE Solutions

-  Global Sourcing Solution
-  Obsolete Management
-  Cost Control Management
-  Shortage Management
-  Alternative Solution
-  Excess Inventory Management