



**THE DATASHEET OF
ZRT050GC1TA**



Description

The ZRT050 is a monolithic integrated circuit providing a precise stable reference voltage of 4.9V at 500µA.

The circuit features a knee current of 150µA and operation over a wide range of temperatures and currents.

The ZRT050 is available in a SOT223 package for surface mount applications. This device offers a trim facility whereby the output voltage can be adjusted as shown in the schematic diagram. This facility is used when compensating for system errors or setting the reference output to a particular value. When the trim facility is not used, the pin should be left open circuit.

Pin Assignments

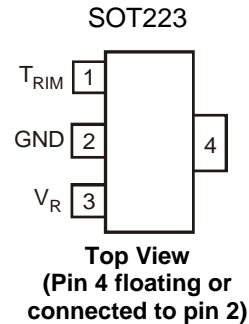

Features

- Trimmable output
- Excellent temperature stability
- Low output noise figure
- -40 to 85°C operating temperature range
- 1% initial voltage tolerance
- No external stabilizing capacitor required in most cases
- Low slope resistance
- No derating required at low temperatures
- SOT223 small outline package

Schematic Diagram

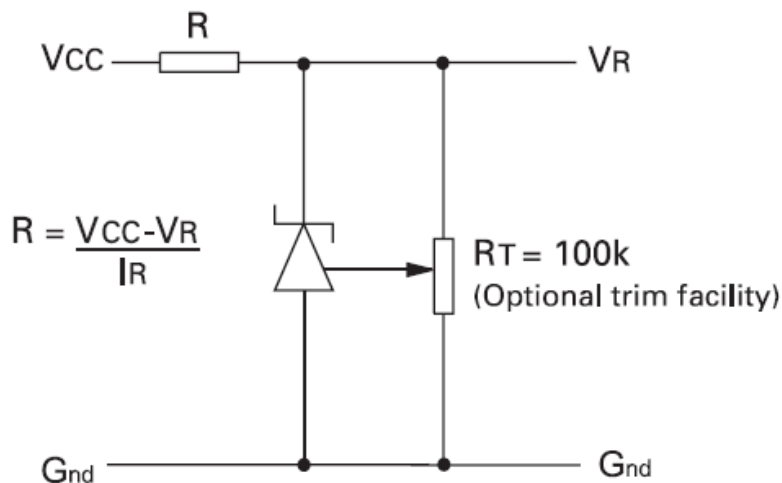

This circuit will allow the reference to be trimmed over a wide range. The device is specified over a ±5% trim range.

Absolute Maximum Ratings

Parameter	Symbol	Value	Unit
Reverse Current (Note 1)		60	mA
Operating Temperature: C grade	T_{OMP}	-40 to +85	°C
Storage Temperature	T_{STG}	-55 to +150	°C

Notes: 1. Above 72°C this figure should be linearly derated to 15mA @ 125°C

Power Dissipation (@ $T_{amb} = 25^{\circ}\text{C}$ unless otherwise stated)

Package	Value	Unit
SOT223	2	W

Temperature Dependent Electrical Characteristics

Symbol	Parameter	Grade C -40 to 85°C		Unit
		Typ.	Max.	
ΔV_R	Output voltage change over operating temperature range	5.4	17.2	mV
$T_C V_R$	Output voltage temperature coefficient (see Note B)	15.0	50.0	ppm/°C

Electrical Characteristics (@ $T_{amb} = 25^{\circ}\text{C}$ unless otherwise stated)

Symbol	Parameter	Conditions	Min.	Typ.	Max.	Unit
V_R	Output voltage: 1% tolerance	$I_R = 500 \mu\text{A}$	4.85	4.90	4.95	V
V_{TRIM}	Output voltage adjustment range	$R_T = 100\text{k}\Omega$		± 5		%
$T_C V_{TRIM}$	Change in $T_C V_R$ with output adjustment			2.5		ppm/°C
I_R	Operating current range	(See Note C)	0.15		60	mA
t_{on} t_{off}	Turn-on time Turn-off time	$R_L = 1\text{k}\Omega$		100 0.3		μs
e_{np-p}	Output voltage noise (over the range 0.1 to 10Hz)	Peak to peak measurement		50		μV
R_S	Slope resistance (see Note D)	$I_R = 0.5\text{mA}$ to 5mA		1.25	2.0	Ω

Typical Characteristics

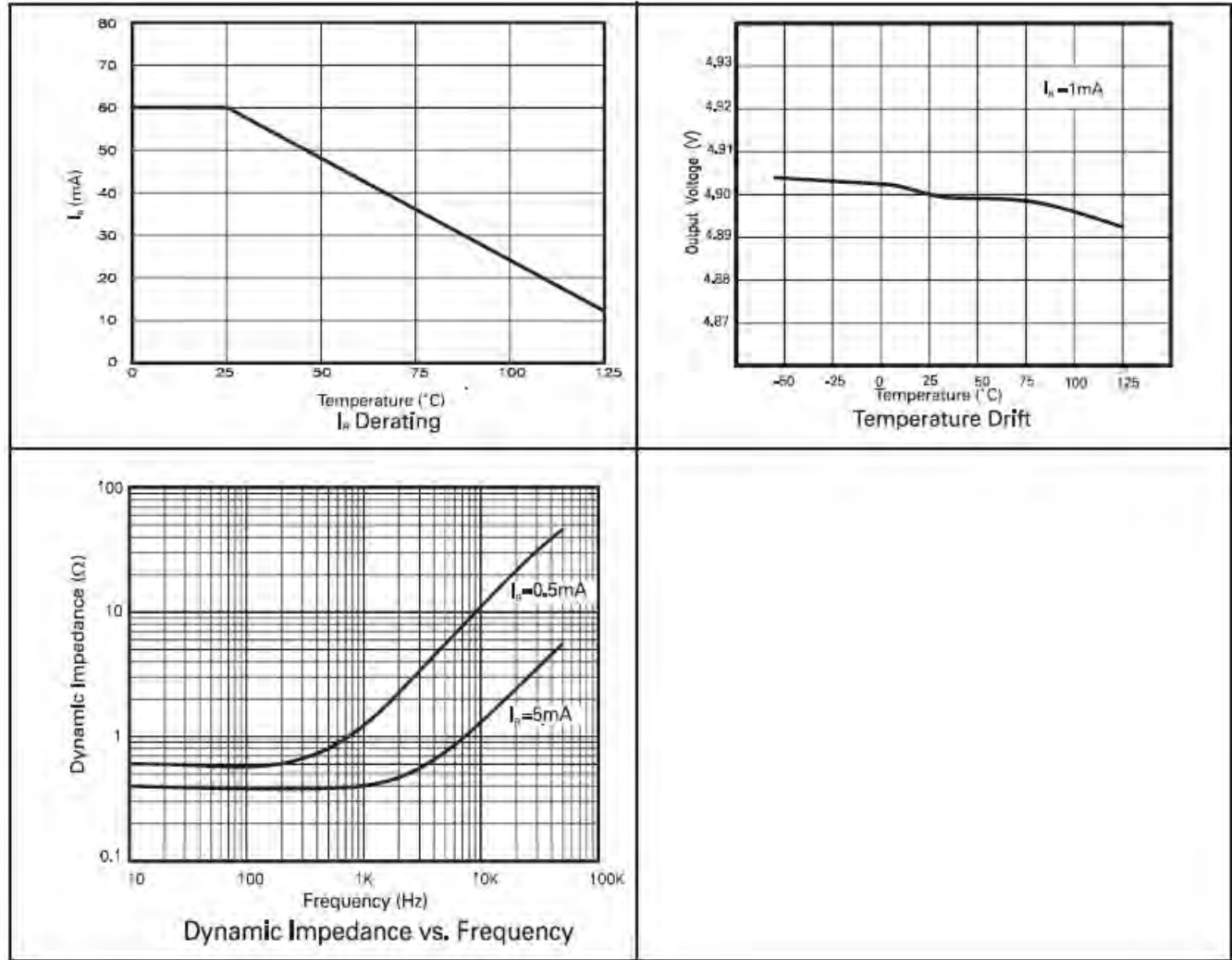

(a) Output change with temperature

The absolute maximum difference between the maximum output voltage and the minimum output voltage over the specified temperature range:

$$\Delta V_R = V_{MAX} - V_{MIN}$$

(b) Output temperature coefficient ($T_C V_R$)

The ratio of the output change with temperature to the specified temperature range expressed in ppm/°C:

$$T_C V_R = \frac{\Delta V_R \times 10^6}{V_R \times \Delta T} \text{ ppm}^\circ\text{C}$$

ΔT = Full temperature range

(c) Operating current (I_R)

Maximum operating current must be derated as indicated in maximum ratings.

(d) Slope resistance (RS)

The slope resistance is defined as:

$$R_S = \frac{\text{change in } V_R}{\text{specific current range}}$$

$$\Delta I = 5 - 0.5 = 4.5 \text{ mA (typically)}$$

(e) Line regulation

The ratio of change in output voltage to the change in input voltage producing it:

$$\frac{R_S \times 100}{V_R \times R_{SOURCE}} \% / V$$

Ordering Information

Device	Tol %	Operating Temperature	Part Mark	Reel Size	Tape Width	Quantity Per Reel
ZRT050GC1	1	-40 to +85°C	ZRT050C1	7"	12mm	1000

Package Outline Dimensions (All Dimensions in mm)

SOT223

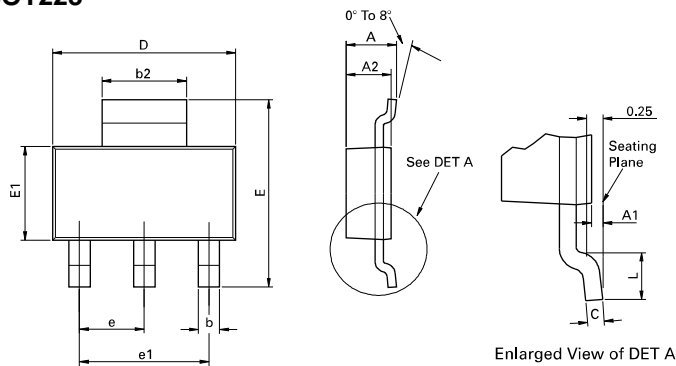

Conforms to JEDEC TO-261 AA Issue B

DIM	Millimeters		Inches		DIM	Millimeters		Inches	
	Min	Max	Min	Max		Min	Max	Min	Max
A	-	1.80	-	0.071	e	2.30 BSC		0.0905 BSC	
A1	0.02	0.10	0.0008	0.004	e1	4.60 BSC		0.181 BSC	
b	0.66	0.84	0.026	0.033	E	6.70	7.30	0.264	0.287
b2	2.90	3.10	0.114	0.122	E1	3.30	3.70	0.130	0.146
C	0.23	0.33	0.009	0.013	L	0.90	-	0.355	-
D	6.30	6.70	0.248	0.264	-	-	-	-	-

Note: Controlling dimensions are in millimeters. Approximate dimensions are provided in inches.

IMPORTANT NOTICE

DIODES INCORPORATED MAKES NO WARRANTY OF ANY KIND, EXPRESS OR IMPLIED, WITH REGARDS TO THIS DOCUMENT, INCLUDING, BUT NOT LIMITED TO, THE IMPLIED WARRANTIES OF MERCHANTABILITY AND FITNESS FOR A PARTICULAR PURPOSE (AND THEIR EQUIVALENTS UNDER THE LAWS OF ANY JURISDICTION).

Diodes Incorporated and its subsidiaries reserve the right to make modifications, enhancements, improvements, corrections or other changes without further notice to this document and any product described herein. Diodes Incorporated does not assume any liability arising out of the application or use of this document or any product described herein; neither does Diodes Incorporated convey any license under its patent or trademark rights, nor the rights of others. Any Customer or user of this document or products described herein in such applications shall assume all risks of such use and will agree to hold Diodes Incorporated and all the companies whose products are represented on Diodes Incorporated website, harmless against all damages.

Diodes Incorporated does not warrant or accept any liability whatsoever in respect of any products purchased through unauthorized sales channel.

Should Customers purchase or use Diodes Incorporated products for any unintended or unauthorized application, Customers shall indemnify and hold Diodes Incorporated and its representatives harmless against all claims, damages, expenses, and attorney fees arising out of, directly or indirectly, any claim of personal injury or death associated with such unintended or unauthorized application.

Products described herein may be covered by one or more United States, international or foreign patents pending. Product names and markings noted herein may also be covered by one or more United States, international or foreign trademarks.

LIFE SUPPORT

Diodes Incorporated products are specifically not authorized for use as critical components in life support devices or systems without the express written approval of the Chief Executive Officer of Diodes Incorporated. As used herein:

A. Life support devices or systems are devices or systems which:

1. are intended to implant into the body, or
2. support or sustain life and whose failure to perform when properly used in accordance with instructions for use provided in the labeling can be reasonably expected to result in significant injury to the user.

B. A critical component is any component in a life support device or system whose failure to perform can be reasonably expected to cause the failure of the life support device or to affect its safety or effectiveness.

Customers represent that they have all necessary expertise in the safety and regulatory ramifications of their life support devices or systems, and acknowledge and agree that they are solely responsible for all legal, regulatory and safety-related requirements concerning their products and any use of Diodes Incorporated products in such safety-critical, life support devices or systems, notwithstanding any devices- or systems-related information or support that may be provided by Diodes Incorporated. Further, Customers must fully indemnify Diodes Incorporated and its representatives against any damages arising out of the use of Diodes Incorporated products in such safety-critical, life support devices or systems.

Copyright © 2011, Diodes Incorporated

www.diodes.com

Looking for pricing, stock, or lifecycle information?

Click below to explore more details on WIN SOURCE:

 [View ZRT050GC1TA on WIN SOURCE](#)

 [Diodes Incorporated](#) Information

Optimize Your Supply Chain with WIN SOURCE Solutions

-  Global Sourcing Solution
-  Obsolete Management
-  Cost Control Management
-  Shortage Management
-  Alternative Solution
-  Excess Inventory Management