



**THE DATASHEET OF  
ZRT100GA1TC**



# ZRT100

---

## 9.8V LOW POWER PRECISION REFERENCE SOURCE

---

### DESCRIPTION

The ZRT100 is a monolithic integrated circuit providing a precise stable reference voltage of 9.8V at 500 $\mu$ A.

The circuit features a knee current of 150 $\mu$ A and operation over a wide range of temperatures and currents.

The ZRT100 is available in a SOT223 package for surface mount applications. This device offers a trim facility whereby the output voltage can be adjusted as shown in Fig.1. This facility is used when compensating for system errors or setting the reference output to a particular value. When the trim facility is not used, the pin should be left open circuit.

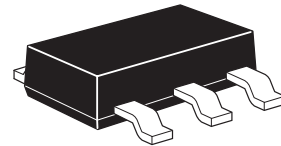

SOT223

### FEATURES

- Trimmable output
- Excellent temperature stability
- Low output noise figure
- Available in two temperature ranges
- 1 and 2% initial voltage tolerance versions available
- No external stabilising capacitor required in most cases
- Low slope resistance
- SOT223 small outline package

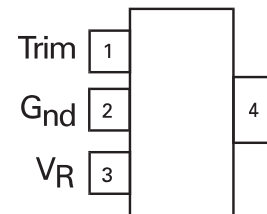

SOT223  
Package suffix G  
Top view (pin 4 floating or  
connected to pin 2)

### ORDERING INFORMATION

DEVICE	TOL%	OPERATING TEMP.	PACKAGE	PARTMARK
ZRT100GC2	2	-40 to 85°C	SOT223	ZRT100C2
ZRT100GC1	1	-40 to 85°C	SOT223	ZRT100C1
ZRT100GA1	1	-55 to 125°C	SOT223	ZRT100A1

A grade -55°C to 125°C

C grade -40°C to 85°C

# ZRT100

## ABSOLUTE MAXIMUM RATINGS

PARAMETER	SYMBOL	LIMIT	UNIT
Reverse current <sup>(1)</sup>		30	mA
Operating temperature: A grade	T <sub>OMP</sub>	-55 to 125	°C
C grade		-40 to 85	°C
Storage temperature	T <sub>STG</sub>	-55 to 150	°C

<sup>(1)</sup> Above 25°C this figure should be linearly derated to 6mA at 125°C

## POWER DISSIPATION (at T<sub>amb</sub> = 25°C unless otherwise stated)

PACKAGE	VALUE	UNIT
SOT223	2	W

## TEMPERATURE DEPENDENT ELECTRICAL CHARACTERISTICS

SYMBOL	PARAMETER	INITIAL VOLTAGE TOLERANCE %	GRADE A		GRADE C		UNIT
			TYP	MAX	TYP	MAX	
ΔV <sub>R</sub>	Output voltage change over relevant temperature range(See note (a))	1 & 2	27.0	90.0	10.8	34.4	mV
T <sub>C</sub> V <sub>R</sub>	Output voltage temperature coefficient (See note (b))	1 & 2	15.0	50.0	15.0	50.0	ppm/°C

## ELECTRICAL CHARACTERISTICS (at T<sub>amb</sub> = 25°C unless otherwise stated)

SYMBOL	PARAMETER	CONDITIONS	MIN.	TYP.	MAX.	UNIT
V <sub>R</sub>	Output voltage	I <sub>R</sub> =500μA	9.70	9.80	9.90	V
	1% tolerance (A1,C1)					
	2% tolerance (C2)		9.60	9.80	10.00	V
ΔV <sub>TRIM</sub>	Output voltage adjustment range	R <sub>T</sub> =100kΩ		±5		%
T <sub>C</sub> ΔV <sub>TRIM</sub>	Change in T <sub>C</sub> V <sub>R</sub> with output adjustment			5.0		ppm/°C/%
I <sub>R</sub>	Operating current range	See note (c)	0.15		30	mA
t <sub>on</sub>	Turn-on time	R <sub>L</sub> =1kΩ		400		μs
t <sub>off</sub>	Turn-off time			0.3		
e <sub>np-p</sub>	Output voltage noise (over the range 0.1 to 10Hz)	Peak to peak measurement		50		μV
R <sub>S</sub>	Slope resistance	I <sub>R</sub> = 0.5mA to 5mA See note (d)		1.8	4.0	Ω

## TYPICAL CHARACTERISTICS

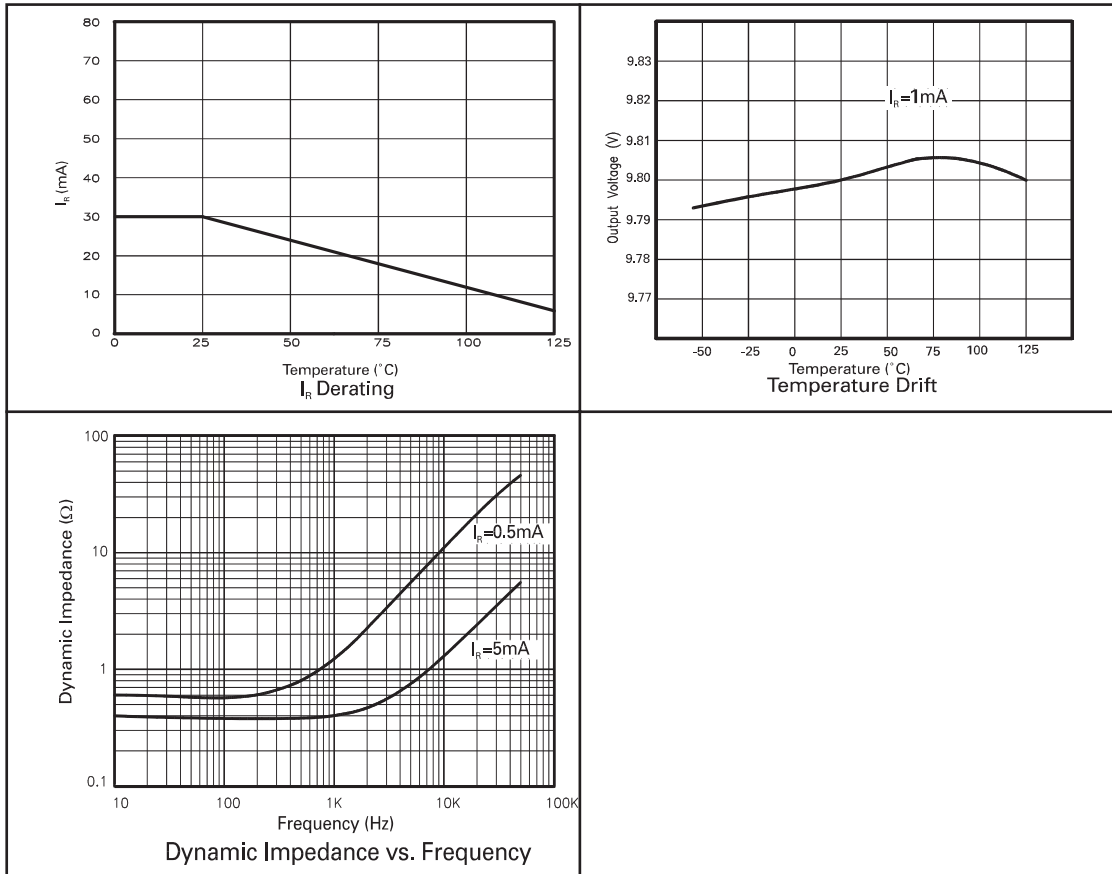

### NOTES:

#### (a) Output change with temperature

The absolute maximum difference between the maximum output voltage and the minimum output voltage over the specified temperature range:

$$\Delta V_R = V_{max} - V_{min}$$

#### (b) Output temperature coefficient (T<sub>c</sub>V<sub>R</sub>)

The ratio of the output change with temperature to the specified temperature range expressed in ppm/°C:

$$T_c V_R = \frac{\Delta V_R \times 10^6}{V_R \times \Delta T} \text{ ppm}^\circ\text{C}$$

ΔT = Full temperature range

#### (c) Operating current (I<sub>r</sub>)

Maximum operating current must be derated as indicated in maximum ratings.

#### (d) Slope resistance (R<sub>S</sub>)

The slope resistance is defined as:

$$R_S = \frac{\text{change in } V_R}{\text{specific current range}}$$

$$\Delta I = 5 - 0.5 = 4.5 \text{ mA (typically)}$$

#### (e) Line regulation

The ratio of change in output voltage to the change in input voltage producing it:

$$\frac{R_S \times 100}{V_R \times R_{SOURCE}} \% / V$$

# ZRT100

## SCHEMATIC DIAGRAM

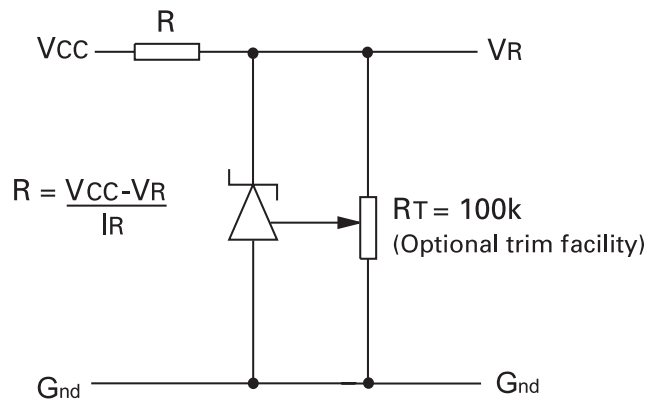

**Figure 1:**  
This circuit will allow the reference to be trimmed over a wide range. The device is specified over a  $\pm 5\%$  trim range.

# ZRT100

## PACKAGE OUTLINE

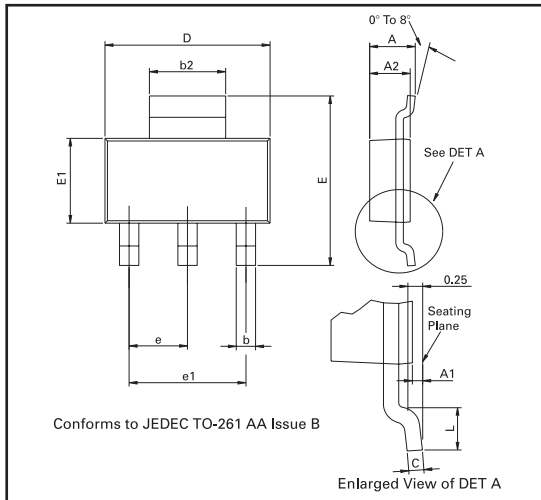

Controlling dimensions are in millimeters. Approximate conversions are given in inches

## PACKAGE DIMENSIONS

DIM	Millimeters		Inches		DIM	Millimeters		Inches	
	Min	Max	Min	Max		Min	Max	Min	Max
A	-	1.80	-	0.071	e	2.30 BSC		0.0905 BSC	
A1	0.02	0.10	0.0008	0.004	e1	4.60 BSC		0.181 BSC	
b	0.66	0.84	0.026	0.033	E	6.70	7.30	0.264	0.287
b2	2.90	3.10	0.114	0.122	E1	3.30	3.70	0.130	0.146
C	0.23	0.33	0.009	0.013	L	0.90	-	0.0355	-
D	6.30	6.70	0.248	0.264		-	-	-	-

© Zetex plc 2003

### Europe

Zetex plc  
Fields New Road  
Chadderton  
Oldham, OL9 8NP  
United Kingdom  
Telephone (44) 161 622 4444  
Fax: (44) 161 622 4446  
hq@zetex.com

Zetex GmbH  
Streitfeldstraße 19  
D-81673 München  
Germany  
Telefon: (49) 89 45 49 49 0  
Fax: (49) 89 45 49 49 49  
europe.sales@zetex.com

### Americas

Zetex Inc  
700 Veterans Memorial Hwy  
Hauppauge, NY 11788  
USA  
Telephone: (1) 631 360 2222  
Fax: (1) 631 360 8222  
usa.sales@zetex.com

### Asia Pacific

Zetex (Asia) Ltd  
3701-04 Metroplaza Tower 1  
Hing Fong Road  
Kwai Fong  
Hong Kong  
Telephone: (852) 26100 611  
Fax: (852) 24250 494  
asia.sales@zetex.com

These offices are supported by agents and distributors in major countries world-wide.

This publication is issued to provide outline information only which (unless agreed by the Company in writing) may not be used, applied or reproduced for any purpose or form part of any order or contract or be regarded as a representation relating to the products or services concerned. The Company reserves the right to alter without notice the specification, design, price or conditions of supply of any product or service.

For the latest product information, log on to [www.zetex.com](http://www.zetex.com)

ISSUE 3 - DECEMBER 2003

## Looking for pricing, stock, or lifecycle information?

Click below to explore more details on WIN SOURCE:

 [View ZRT100GA1TC on WIN SOURCE](#)

 [Diodes Incorporated](#) Information

## Optimize Your Supply Chain with WIN SOURCE Solutions

-  Global Sourcing Solution
-  Obsolete Management
-  Cost Control Management
-  Shortage Management
-  Alternative Solution
-  Excess Inventory Management