



**THE DATASHEET OF
ZTL431AFTA**



COST EFFECTIVE ADJUSTABLE PRECISION SHUNT REGULATOR
Description

The ZTL431 and ZTL432 are three terminal adjustable shunt regulators offering excellent temperature stability and output current handling capability up to 100mA. The output voltage may be set to any chosen voltage between 2.5 and 20 volts by selection of two external divider resistors.

The devices can be used as a replacement for zener diodes in many applications requiring an improvement in zener performance.

The ZTL432 has the same electrical specifications as the ZTL431 but has a different pin out in SOT23 (F-suffix) and SOT23F (FF-suffix).

Both variants are available in two grades with initial tolerances of 1% and 0.5% for the A and B grades, respectively.

These are functionally equivalent to the TL431/ TL432 except for maximum operation voltage, and have an ambient temperature range of -40°C to +125°C as standard.

Features

- Temperature Range -40°C to +125°C
- Reference Voltage Tolerance at +25°C
 - 0.5%.....B grade
 - 1%A grade
- 0.2Ω Typical Output Impedance
- Sink Current Capability..... 1mA to 100mA
- Adjustable Output Voltage..... V_{REF} to 20V
- **Totally Lead-Free & Fully RoHS Compliant (Notes 1 & 2)**
- **Halogen and Antimony Free. "Green" Device (Note 3)**

Applications

- Opto-Coupler Linearization
- Linear Regulators
- Improved Zener
- Variable Reference

- Notes:
1. No purposely added lead. Fully EU Directive 2002/95/EC (RoHS) & 2011/65/EU (RoHS 2) compliant.
 2. See http://www.diodes.com/quality/lead_free.html for more information about Diodes Incorporated's definitions of Halogen and Antimony-free, "Green" and Lead-free.
 3. Halogen- and Antimony-free "Green" products are defined as those which contain <900ppm bromine, <900ppm chlorine (<1500ppm total Br + Cl) and <1000ppm antimony compounds.

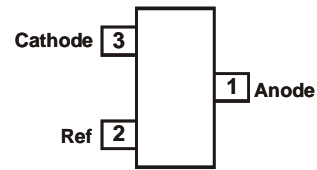
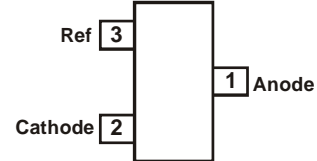
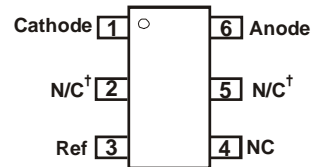
Pin Assignments
ZTL431_F SOT23, ZTL431_FF SOT23F
(Top View)

ZTL432_F SOT23, ZTL432_FF SOT23F
(Top View)

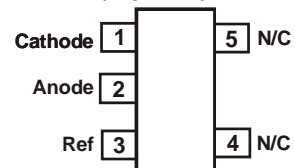
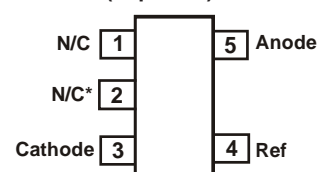
ZTL431_H6, SOT363
(Top View)

†Connected internally to substrate; should be left floating or connected to Anode

ZTL431ASE5 SOT25
(Top View)

ZTL431_E5 SOT25
(Top View)

*must be left floating or connected to pin 5

Absolute Maximum Ratings (Voltages specified are relative to the ANODE pin unless otherwise stated.)

Parameter	Rating	Unit
Cathode Voltage (V_{KA})	20	V
Continuous Cathode Current (I_{KA})	150	mA
Reference Input Current Range (I_{REF})	-50 μ A to +10mA	-
Operating Junction Temperature	-40 to +150	$^{\circ}$ C
Storage Temperature	-55 to +150	$^{\circ}$ C

Operation above the absolute maximum rating may cause device failure.
 Operation at the absolute maximum ratings, for extended periods, may reduce device reliability.

Package Thermal Data

Package	θ_{JA}	P_{DIS} $T_A = +25^{\circ}$ C, $T_J = +150^{\circ}$ C
SOT23	380 $^{\circ}$ C/W	330mW
SOT23F	138 $^{\circ}$ C/W	900mW
SOT25	250 $^{\circ}$ C/W	500mW
SOT363	380 $^{\circ}$ C/W	330mW

Recommended Operating Conditions (@ $T_A = +25^{\circ}$ C, unless otherwise specified.)

Symbol	Parameter	Min	Max	Unit
V_{KA}	Cathode Voltage	V_{REF}	20	V
I_{KA}	Cathode Current	1	100	mA
T_A	Operating Ambient Temperature Range	-40	+125	$^{\circ}$ C

Electrical Characteristics (@ $T_A = +25^{\circ}$ C, unless otherwise specified.)

Symbol	Parameter	Conditions	Min	Typ	Max	Units	
V_{REF}	Reference Voltage	$V_{KA} = V_{REF}$ $I_{KA} = 10$ mA	ZTL43_A	2.475	2.5	2.525	V
			ZTL43_B	2.487	2.5	2.513	
V_{DEV}	Deviation of Reference Voltage Over Full Temperature Range	$V_{KA} = V_{REF}$ $I_{KA} = 10$ mA	$T_A = 0$ to $+70^{\circ}$	-	6	16	mV
			$T_A = -40$ to $+85^{\circ}$ C	-	14	34	
			$T_A = -40$ to $+125^{\circ}$ C	-	14	34	
$\frac{\Delta V_{REF}}{\Delta V_{KA}}$	Ratio of Change In Reference Voltage To the Change In Cathode Voltage	$I_{KA} = 10$ mA	$V_{KA} = V_{REF}$ to 10	-	-1.4	-2.7	mV/V
			$V_{KA} = 10$ V to 20V	-	-1.0	-2.0	
I_{REF}	Reference Input Current	$I_{KA} = 10$ mA, $R_1 = 10$ k Ω , $R_2 = OC$	-	2	4	μ A	
ΔI_{REF}	I_{REF} Deviation Over Full Temperature Range	$I_{KA} = 10$ mA $R_1 = 10$ k Ω $R_2 = OC$	$T_A = 0$ to $+70^{\circ}$ C	-	0.8	1.2	μ A
			$T_A = -40$ to $+85^{\circ}$ C	-	0.8	2.5	
			$T_A = -40$ to $+125^{\circ}$ C	-	0.8	2.5	
$I_{KA(MIN)}$	Minimum Cathode Current for Regulation	$V_{KA} = V_{REF}$	-	0.4	0.6	mA	
$I_{KA(OFF)}$	Off-State Current	$V_{KA} = 20$ V, $V_{REF} = 0$ V	-	0.1	0.5	μ A	
R_Z	Dynamic Output Impedance	$V_{KA} = V_{REF}$, $f = 0$ Hz	-	0.2	0.5	Ω	

Typical Characteristics

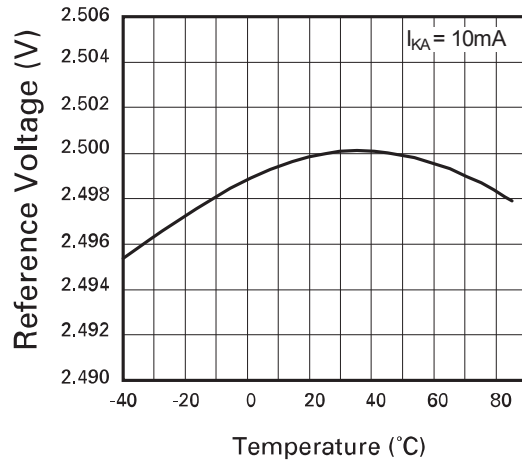

Reference Voltage vs. Temperature

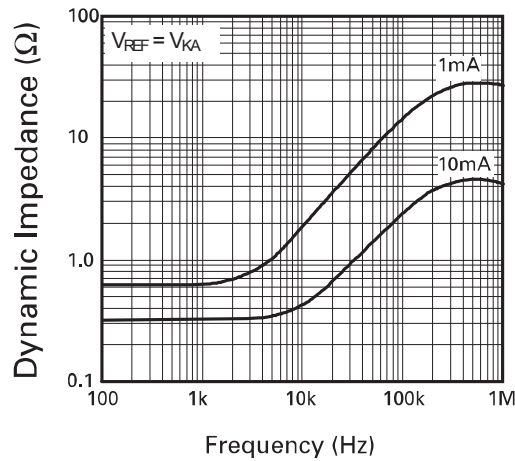

Dynamic Impedance vs. Frequency

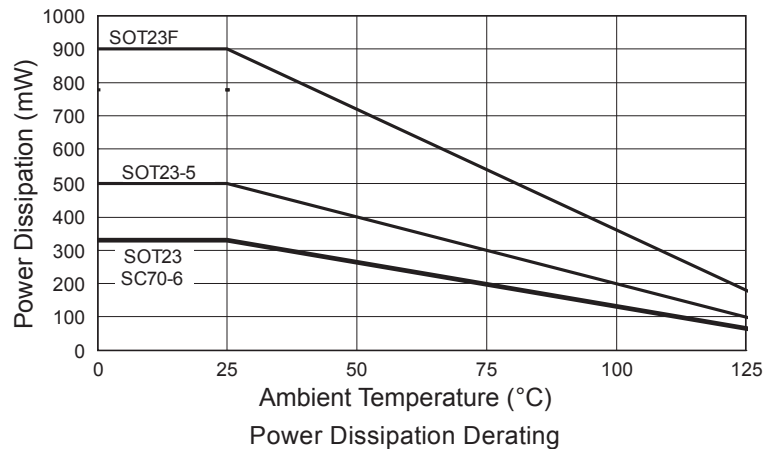

Power Dissipation Derating

Typical Characteristics (continued)

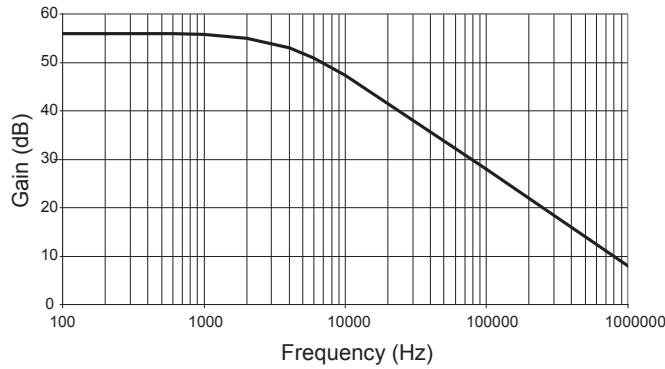

Gain vs. Frequency

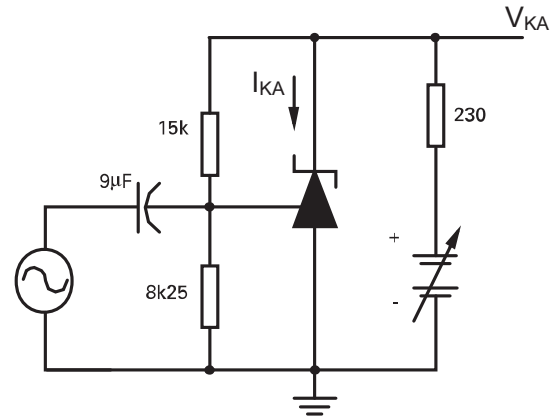

$I_{KA} = 10\text{mA}$, $T_A = 25^\circ\text{C}$

Test Circuit for Open Loop Voltage Gain

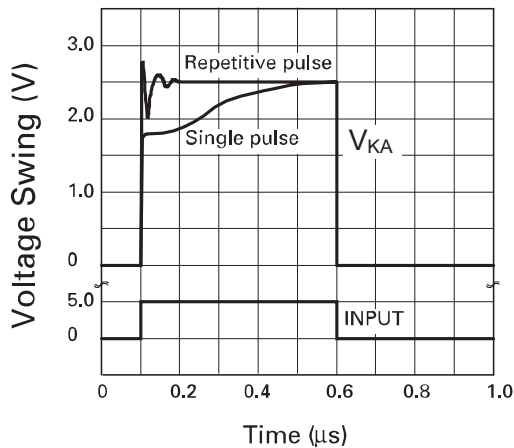

Pulse Response

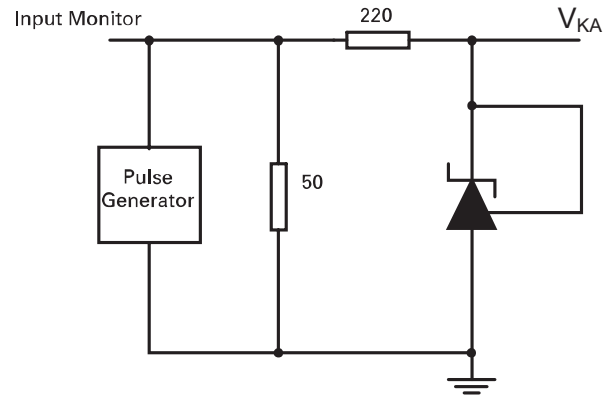

$T_A = 25^\circ\text{C}$

Test Circuit for Pulse Response

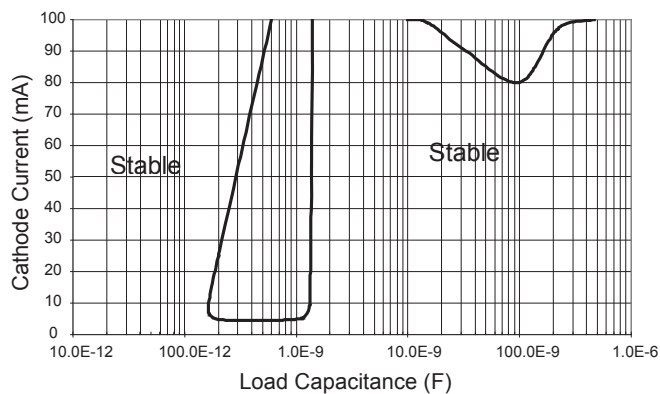

Stability Boundary Condition

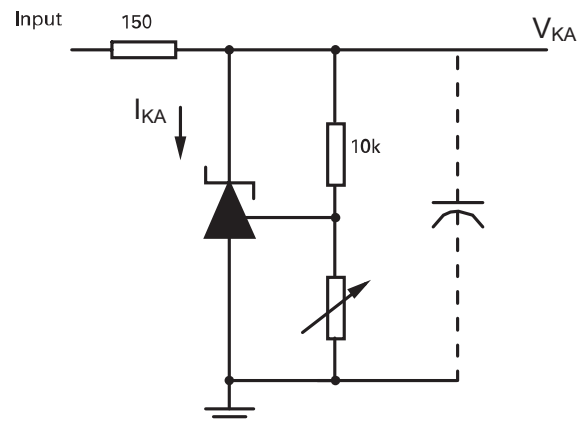

$V_{REF} < V_{KA} < 20$, $I_{KA} = 10\text{mA}$, $T_A = 25^\circ\text{C}$

Test Circuit for Stability Boundary Conditions

Application Circuits

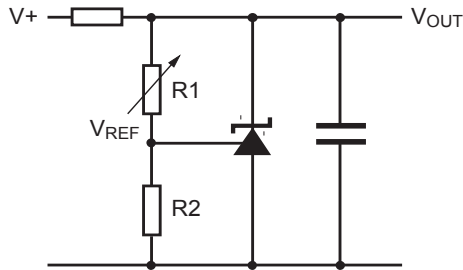

$$V_{OUT} = \left(1 + \frac{R1}{R2}\right) V_{REF}$$

Shunt regulator

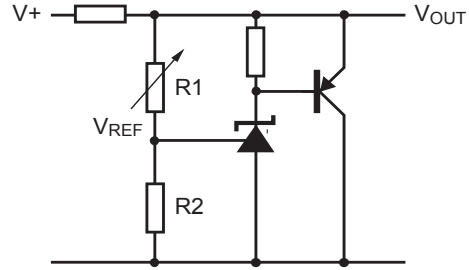

$$V_{OUT} = \left(1 + \frac{R1}{R2}\right) V_{REF}$$

Higher current shunt regulator

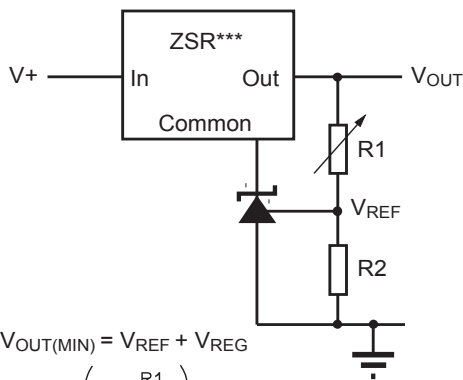

$$V_{OUT(MIN)} = V_{REF} + V_{REG}$$

$$V_{OUT} = \left(1 + \frac{R1}{R2}\right) V_{REF}$$

Output control of a three terminal fixed regulator

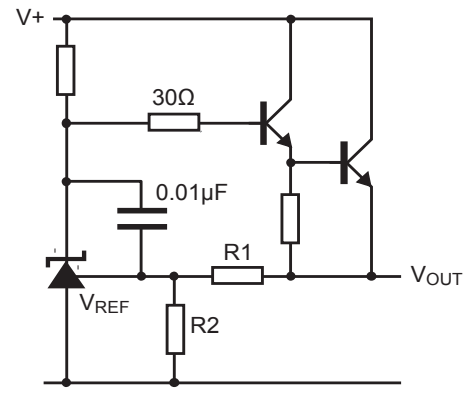

$$V_{OUT} = \left(1 + \frac{R1}{R2}\right) V_{REF}$$

Series regulator

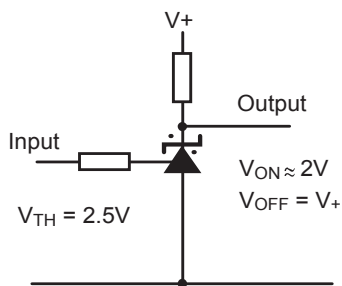

Single supply comparator with temperature compensated threshold

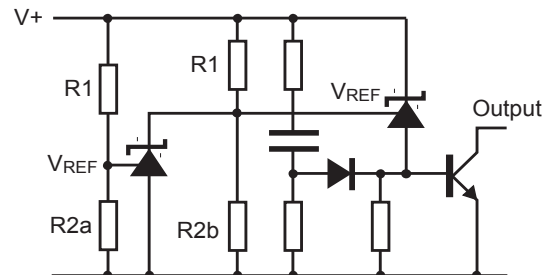

$$\text{Low limit} = \left(1 + \frac{R1B}{R2B}\right) V_{REF}$$

$$\text{High limit} = \left(1 + \frac{R1A}{R2A}\right) V_{REF}$$

Over voltage / under voltage protection circuit

DC Test Circuits

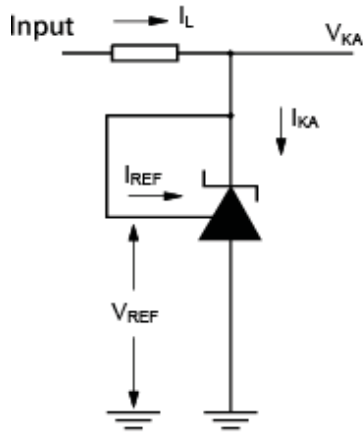

Figure 1. Test circuit for $V_{KA} = V_{REF}$

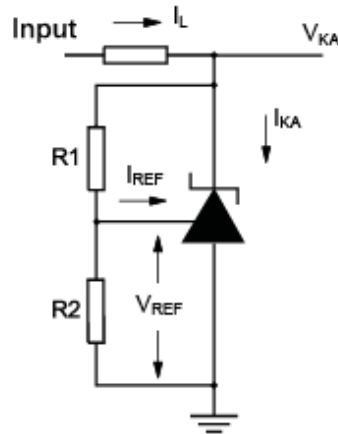

Figure 2. Test circuit for $V_{KA} > V_{REF}$

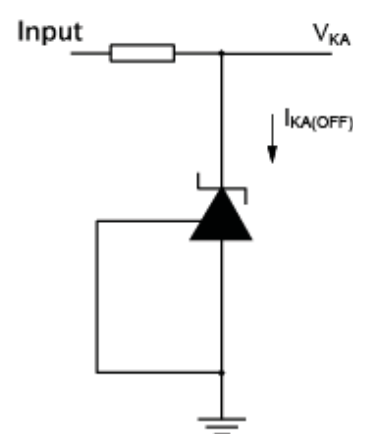

Figure 3. Test circuit for off state current

Notes

Deviation of reference input voltage, V_{dev} , is defined as the maximum variation of the reference input voltage over the full temperature range.

The average temperature coefficient of the reference input voltage, V_{REF} is defined as:

$$V_{REF}(ppm/^{\circ}C) = \frac{V_{DEV} \times 1,000,000}{V_{REF}(T1-T2)}$$

The dynamic output impedance, R_z , is defined as:

$$R_z = \frac{\Delta V_z}{\Delta I_z}$$

When the device is programmed with two external resistors, $R1$ and $R2$, (Figure 2), the dynamic output impedance of the overall circuit, R'_z , is defined as:

$$R'_z = R_z \left(1 + \frac{R1}{R2} \right)$$

Stability Boundary

The ZTL431 and ZTL432 are stable with a range of capacitive loads. A zone of instability exists as demonstrated in the typical characteristic graph on page 4. The graph shows typical conditions. To ensure reliable stability, a capacitor of 4.7nF or greater is recommended between anode and cathode.

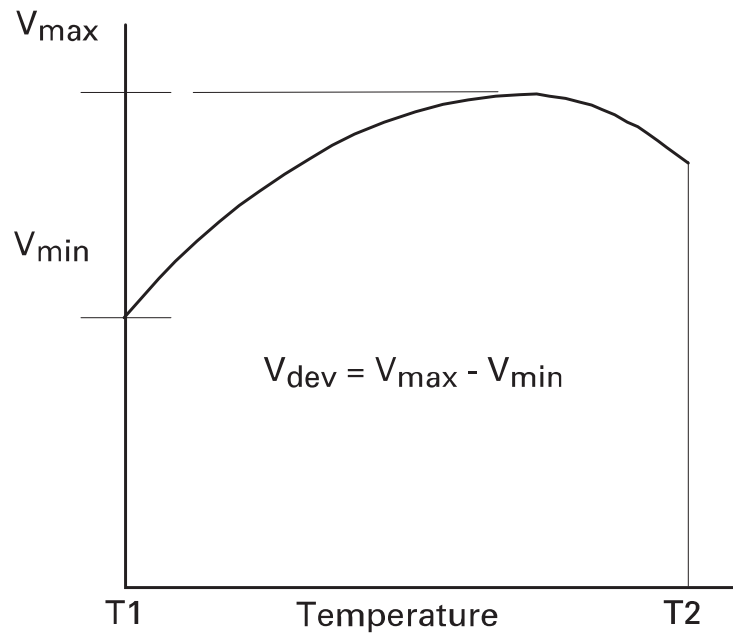

Ordering Information

Tol.	Ordering Code	Pack	Part Mark	Status*	Reel Size	Tape Width (mm)	Quantity per Reel
1%	ZTL431AE5TA	SOT25	31A	Active	7", 180mm	8	3,000
	ZTL431AFFTA	SOT23F	31A	Active	7", 180mm	8	3,000
	ZTL431AFTA	SOT23	31A	Active	7", 180mm	8	3,000
	ZTL431AH6TA	SOT363	31A	Active	7", 180mm	8	3,000
	ZTL431ASE5TA	SOT25	S2A	Active	7", 180mm	8	3,000
	ZTL432AFFTA	SOT23F	32A	Active	7", 180mm	8	3,000
	ZTL432AFTA	SOT23	32A	Active	7", 180mm	8	3,000
0.5%	ZTL431BE5TA	SOT25	31B	Active	7", 180mm	8	3,000
	ZTL431BFFTA	SOT23F	31B	Active	7", 180mm	8	3,000
	ZTL431BFTA	SOT23	31B	Active	7", 180mm	8	3,000
	ZTL431BH6TA	SOT363	31B	Active	7", 180mm	8	3,000
	ZTL432BFFTA	SOT23F	32B	Active	7", 180mm	8	3,000
	ZTL432BFTA	SOT23	32B	Active	7", 180mm	8	3,000

Package Outline Dimensions

Please see AP02002 at <http://www.diodes.com/datasheets/ap02002.pdf> for the latest version.

SOT23

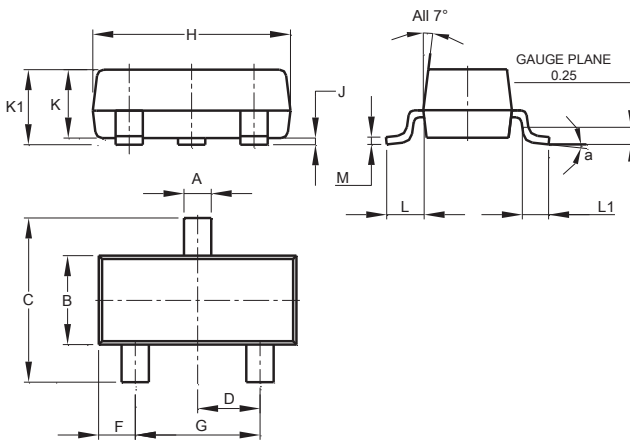

SOT23			
Dim	Min	Max	Typ
A	0.37	0.51	0.40
B	1.20	1.40	1.30
C	2.30	2.50	2.40
D	0.89	1.03	0.915
F	0.45	0.60	0.535
G	1.78	2.05	1.83
H	2.80	3.00	2.90
J	0.013	0.10	0.05
K	0.890	1.00	0.975
K1	0.903	1.10	1.025
L	0.45	0.61	0.55
L1	0.25	0.55	0.40
M	0.085	0.150	0.110
a	8°		
All Dimensions in mm			

SOT23F

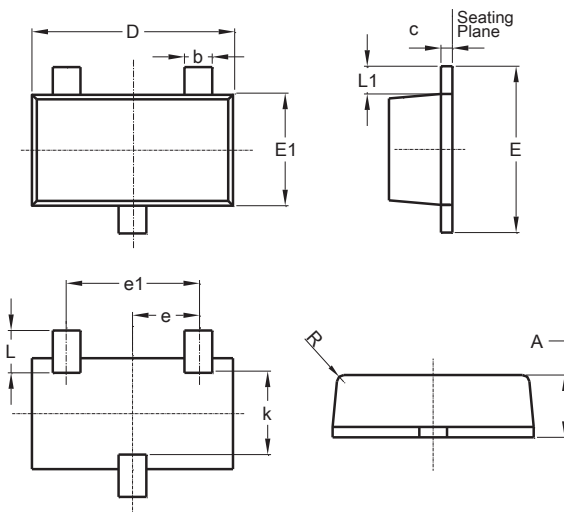

SOT23F			
Dim	Min	Max	Typ
A	0.80	1.00	0.90
b	0.35	0.45	0.40
c	0.06	0.16	0.11
D	2.80	3.00	2.90
e	-	-	0.95
e1	-	-	1.90
E	2.30	2.50	2.40
E1	1.50	1.70	1.60
k	1.10	1.26	1.18
L	0.48	0.68	0.58
L1	0.39	0.41	0.40
R	0.05	0.15	0.10
All Dimensions in mm			

Package Outline Dimensions (continued)

Please see AP02002 at <http://www.diodes.com/datasheets/ap02002.pdf> for the latest version.

SOT363

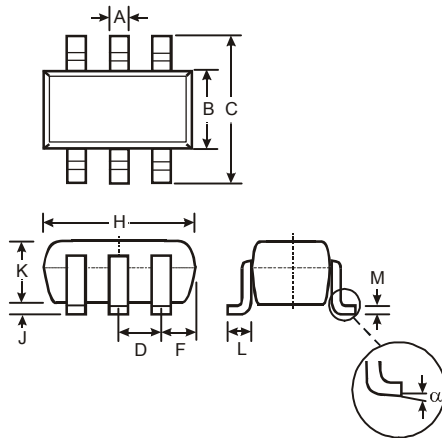

SOT363			
Dim	Min	Max	Typ
A	0.10	0.30	0.25
B	1.15	1.35	1.30
C	2.00	2.20	2.10
D	0.65 Typ		
F	0.40	0.45	0.425
H	1.80	2.20	2.15
J	0	0.10	0.05
K	0.90	1.00	1.00
L	0.25	0.40	0.30
M	0.10	0.22	0.11
α	0°	8°	-
All Dimensions in mm			

SOT25

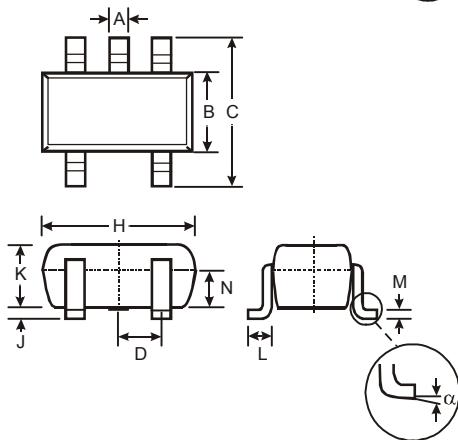

SOT25			
Dim	Min	Max	Typ
A	0.35	0.50	0.38
B	1.50	1.70	1.60
C	2.70	3.00	2.80
D	—	—	0.95
H	2.90	3.10	3.00
J	0.013	0.10	0.05
K	1.00	1.30	1.10
L	0.35	0.55	0.40
M	0.10	0.20	0.15
N	0.70	0.80	0.75
α	0°	8°	—
All Dimensions in mm			

Suggested Pad Layout

Please see AP02001 at <http://www.diodes.com/datasheets/ap02001.pdf> for the latest version.

SOT23

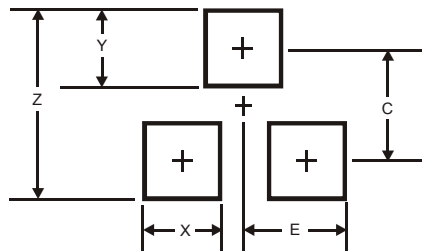

Dimensions	Value (in mm)
Z	2.9
X	0.8
Y	0.9
C	2.0
E	1.35

SOT23F

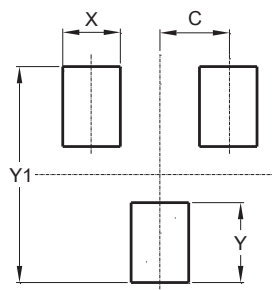

Dimensions	Value (in mm)
C	0.95
X	0.80
Y	1.110
Y1	3.000

Suggested Pad Layout (continued)

Please see AP02001 at <http://www.diodes.com/datasheets/ap02001.pdf> for the latest version.

SOT363

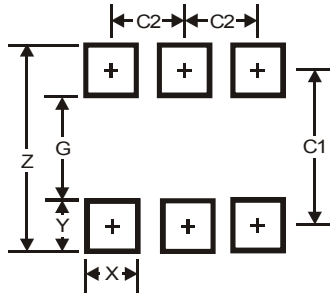

Dimensions	Value (in mm)
Z	2.5
G	1.3
X	0.42
Y	0.6
C1	1.9
C2	0.65

SOT25

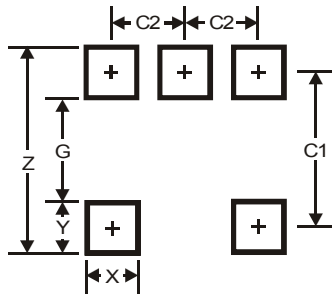

Dimensions	Value (in mm)
Z	3.20
G	1.60
X	0.55
Y	0.80
C1	2.40
C2	0.95

IMPORTANT NOTICE

DIODES INCORPORATED MAKES NO WARRANTY OF ANY KIND, EXPRESS OR IMPLIED, WITH REGARDS TO THIS DOCUMENT, INCLUDING, BUT NOT LIMITED TO, THE IMPLIED WARRANTIES OF MERCHANTABILITY AND FITNESS FOR A PARTICULAR PURPOSE (AND THEIR EQUIVALENTS UNDER THE LAWS OF ANY JURISDICTION).

Diodes Incorporated and its subsidiaries reserve the right to make modifications, enhancements, improvements, corrections or other changes without further notice to this document and any product described herein. Diodes Incorporated does not assume any liability arising out of the application or use of this document or any product described herein; neither does Diodes Incorporated convey any license under its patent or trademark rights, nor the rights of others. Any Customer or user of this document or products described herein in such applications shall assume all risks of such use and will agree to hold Diodes Incorporated and all the companies whose products are represented on Diodes Incorporated website, harmless against all damages.

Diodes Incorporated does not warrant or accept any liability whatsoever in respect of any products purchased through unauthorized sales channel.

Should Customers purchase or use Diodes Incorporated products for any unintended or unauthorized application, Customers shall indemnify and hold Diodes Incorporated and its representatives harmless against all claims, damages, expenses, and attorney fees arising out of, directly or indirectly, any claim of personal injury or death associated with such unintended or unauthorized application.

Products described herein may be covered by one or more United States, international or foreign patents pending. Product names and markings noted herein may also be covered by one or more United States, international or foreign trademarks.

This document is written in English but may be translated into multiple languages for reference. Only the English version of this document is the final and determinative format released by Diodes Incorporated.

LIFE SUPPORT

Diodes Incorporated products are specifically not authorized for use as critical components in life support devices or systems without the express written approval of the Chief Executive Officer of Diodes Incorporated. As used herein:

A. Life support devices or systems are devices or systems which:

1. are intended to implant into the body, or
2. support or sustain life and whose failure to perform when properly used in accordance with instructions for use provided in the labeling can be reasonably expected to result in significant injury to the user.

B. A critical component is any component in a life support device or system whose failure to perform can be reasonably expected to cause the failure of the life support device or to affect its safety or effectiveness.

Customers represent that they have all necessary expertise in the safety and regulatory ramifications of their life support devices or systems, and acknowledge and agree that they are solely responsible for all legal, regulatory and safety-related requirements concerning their products and any use of Diodes Incorporated products in such safety-critical, life support devices or systems, notwithstanding any devices- or systems-related information or support that may be provided by Diodes Incorporated. Further, Customers must fully indemnify Diodes Incorporated and its representatives against any damages arising out of the use of Diodes Incorporated products in such safety-critical, life support devices or systems.

Copyright © 2015, Diodes Incorporated

www.diodes.com

Looking for pricing, stock, or lifecycle information?

Click below to explore more details on WIN SOURCE:

-  [View ZTL431AFTA on WIN SOURCE](#)
-  [Diodes Incorporated Information](#)

Optimize Your Supply Chain with WIN SOURCE Solutions

-  Global Sourcing Solution
-  Obsolete Management
-  Cost Control Management
-  Shortage Management
-  Alternative Solution
-  Excess Inventory Management