



**THE DATASHEET OF
ZVN4525E6TA**



Product Summary

BV _{DSS}	Max R _{DS(ON)}	Max I _D T _A = +25°C
250V	8.5Ω @ V _{GS} = 10V	230mA

Description and Applications

This 250V enhancement mode N-channel MOSFET provides users with a competitive specification. It offers efficient power handling capability, high impedance and is free from thermal runaway and thermally induced secondary breakdowns. Applications benefiting from this device include a variety of telecom and general high-voltage circuits.

SOT89 and SOT223 versions are also available.

- Earth recall and dialing switches
- Electronic hook switches
- High-voltage power MOSFET drivers
- Telecom call routers
- Solid-state relays



Top View

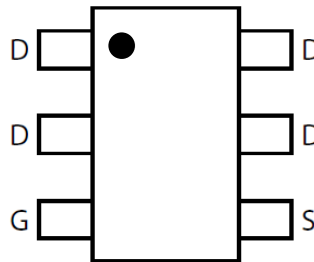

Pinout Top-View

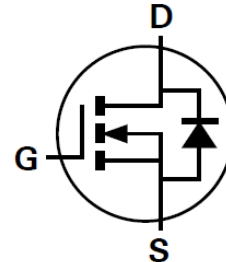

Device Symbol

Features and Benefits

- High Voltage
- Low On-Resistance
- Fast Switching Speed
- Low Threshold
- Low Gate Drive
- Complementary P-Channel Type ZVP4525E6
- **Totally Lead-Free & Fully RoHS Compliant (Notes 1 & 2)**
- **Halogen and Antimony Free. "Green" Device (Note 3)**
- **For automotive applications requiring specific change control (i.e. parts qualified to AEC-Q100/101/104/200, PPAP capable, and manufactured in IATF 16949 certified facilities), please [contact us](mailto:contact@diodes.com) or your local Diodes representative. <https://www.diodes.com/quality/product-definitions/>**

Mechanical Data

- Package: SOT26
- Package Material: Molded Plastic, "Green" Molding Compound. UL Flammability Classification Rating 94V-0
- Moisture Sensitivity: Level 1 per J-STD-020
- Terminals: Finish – Matte Tin Annealed over Copper Leadframe. Solderable per MIL-STD-202, Method 208 Ⓔ3
- Weight: 0.015 grams (Approximate)

Ordering Information (Note 4)

Part Number	Package	Reel Size (inch)	Tape Width (mm)	Packing	
				Qty.	Carrier
ZVN4525E6TA	SOT26	7	8	3000	Reel
ZVN4525E6TC	SOT26	13	8	10,000	Reel

- Notes:
1. No purposely added lead. Fully EU Directive 2002/95/EC (RoHS), 2011/65/EU (RoHS 2) & 2015/863/EU (RoHS 3) compliant.
 2. See <https://www.diodes.com/quality/lead-free/> for more information about Diodes Incorporated's definitions of Halogen- and Antimony-free, "Green" and Lead-free.
 3. Halogen- and Antimony-free "Green" products are defined as those which contain <900ppm bromine, <900ppm chlorine (<1500ppm total Br + Cl) and <1000ppm antimony compounds.
 4. For packaging details, go to our website at <https://www.diodes.com/design/support/packaging/diodes-packaging/>.

Marking Information

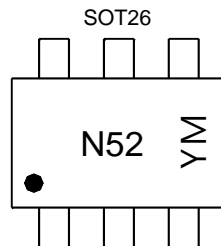

N52 = Product Type Marking Code
 YM = Date Code Marking
 Y or \bar{Y} = Year (ex: L = 2024)
 M or \bar{M} = Month (ex: 4 = April)

Date Code Key

Year	2015	-	2024	2025	2026	2027	2028	2029	2030	2031	2032	2033
Code	C	-	L	M	N	P	R	S	T	U	V	W

Month	Jan	Feb	Mar	Apr	May	Jun	Jul	Aug	Sep	Oct	Nov	Dec
Code	1	2	3	4	5	6	7	8	9	O	N	D

Maximum Ratings (@T_A = +25°C, unless otherwise specified.)

Characteristic		Symbol	Value	Unit	
Drain-Source Voltage		V _{DS}	250	V	
Gate-Source Voltage		V _{GS}	±40	V	
Continuous Drain Current	V _{GS} = 10V	I _D	T _A = +25°C (Note 5)	230	mA
			T _A = +70°C (Note 5)	183	
Pulsed Drain Current (Note 7)		I _{DM}	1.44	A	
Continuous Source Current (Body Diode)		I _S	1.1	A	
Pulsed Source Current (Body Diode)		I _{SM}	1.44	A	

Thermal Characteristics (@T_A = +25°C, unless otherwise specified.)

Characteristic	Symbol	Value	Unit
Power Dissipation at T _A = +25°C (Note 5)	P _D	1.1	W
Linear Derating Factor		8.8	mW/°C
Junction to Ambient (Note 5)	R _{θJA}	113	°C/W
Junction to Ambient (Note 6)	R _{θJA}	65	°C/W
Operating and Storage Temperature Range	T _J , T _{STG}	-55 to +150	°C

- Notes:
- 5. For a device surface mounted on 25mm x 25mm FR4 PCB with high coverage of single sided 1oz copper, in still air conditions.
 - 6. For a device surface mounted on FR4 PCB measured at t ≤ 5 secs.
 - 7. Repetitive rating - pulse width limited by maximum junction temperature. Refer to Transient Thermal.

NB High Voltage Applications

For high voltage applications, the appropriate industry sector guidelines should be considered with regards to voltage spacing between conductors.

Thermal Characteristics

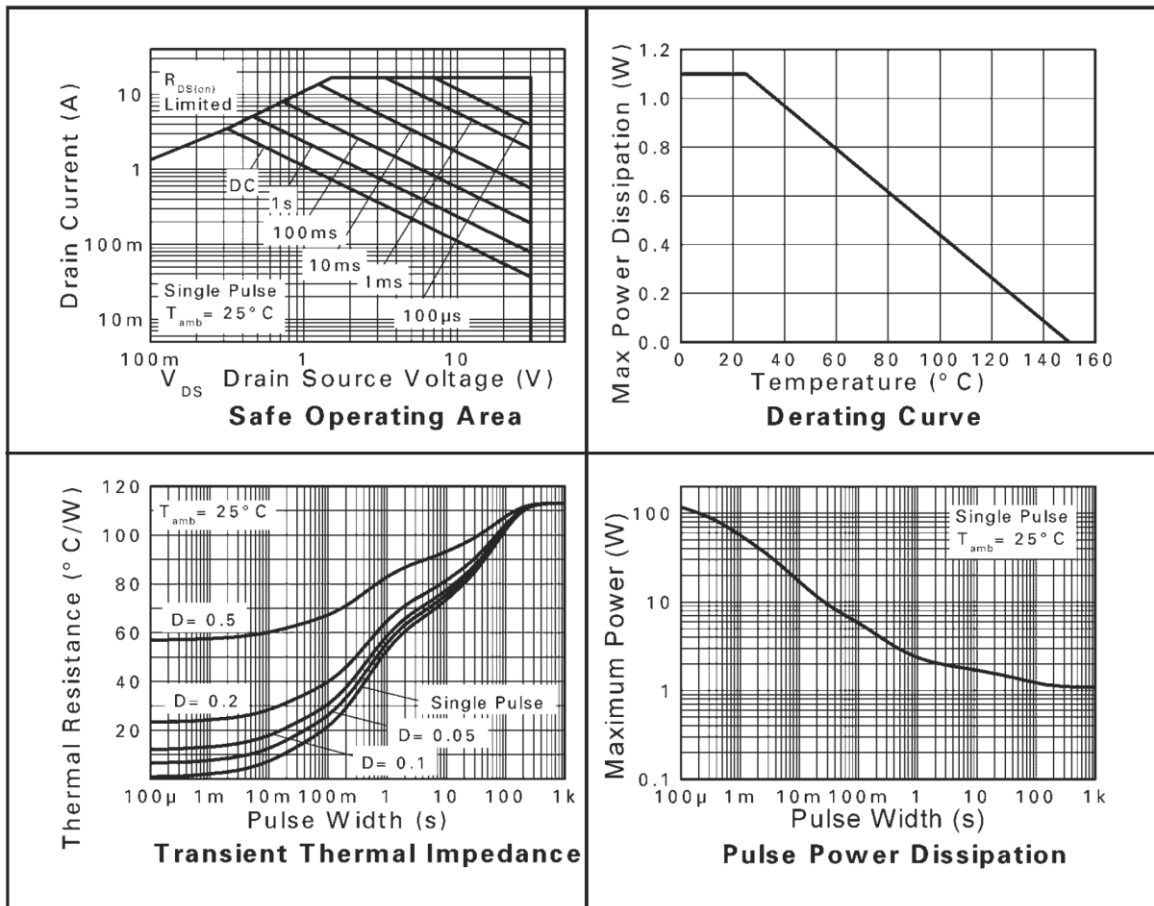

Electrical Characteristics (@T_A = +25°C, unless otherwise specified.)

Characteristic	Symbol	Min	Typ	Max	Unit	Test Condition
OFF CHARACTERISTICS						
Drain-Source Breakdown Voltage	BV _{DSS}	250	285	—	V	I _D = 1mA, V _{GS} = 0
Zero Gate Voltage Drain Current	I _{DSS}	—	35	500	nA	V _{DS} = 250V, V _{GS} = 0
Gate-Body Leakage	I _{GSS}	—	±1	100	nA	V _{GS} = ±40V, V _{DS} = 0
ON CHARACTERISTICS						
Gate-Source Threshold Voltage	V _{GS(th)}	0.8	1.4	1.8	V	I _D = 1mA, V _{DS} = V _{GS}
Static Drain-Source On-State Resistance (Note 8)	R _{DS(on)}	—	5.6	8.5	Ω	V _{GS} = 10V, I _D = 500mA
			5.9	9.0		V _{GS} = 4.5V, I _D = 360mA
			6.4	9.5		V _{GS} = 2.4V, I _D = 20mA
Forward Transconductance (Note 10)	g _{fs}	0.3	0.475	—	S	V _{DS} = 10V, I _D = 0.3A
Diode Forward Voltage (Note 8)	V _{SD}	—	—	0.97	V	T _J = +25°C, I _S = 360mA, V _{GS} = 0
DYNAMIC CHARACTERISTICS (Notes 9 & 10)						
Input Capacitance	C _{iss}	—	72	—	pF	V _{DS} = 25V, V _{GS} = 0, f = 1MHz
Output Capacitance	C _{oss}	—	11	—	pF	
Reverse Transfer Capacitance	C _{rss}	—	3.6	—	pF	
Total Gate Charge	Q _g	—	2.6	3.65	nC	V _{GS} = 10V, V _{DS} = 25V, I _D = 360mA (refer to test circuit)
Gate-Source Charge	Q _{gs}	—	0.2	0.28	nC	
Gate-Drain Charge	Q _{gd}	—	0.5	0.7	nC	
Reverse-Recovery Time (Note 10)	t _{rr}	—	186	260	ns	T _J = +25°C, I _F = 360A, di/dt = 100A/μs
Reverse-Recovery Charge (Note 10)	Q _{rr}	—	34	48	nC	
Turn-On Delay Time	t _{d(on)}	—	1.25	—	ns	V _{DD} = 30V, V _{GS} = 10V, I _D = 360mA, R _G = 50Ω (refer to test circuit)
Turn-On Rise Time	t _r	—	1.7	—	ns	
Turn-Off Delay Time	t _{d(off)}	—	11.40	—	ns	
Turn-Off Fall Time	t _f	—	3.5	—	ns	

- Notes:
- 8. Measured under pulsed conditions. Width = 300μs. Duty cycle ≤ 2%.
 - 9. Switching characteristics are independent of operating junction temperature.
 - 10. For design aid only, not subject to production testing.

Typical Characteristics

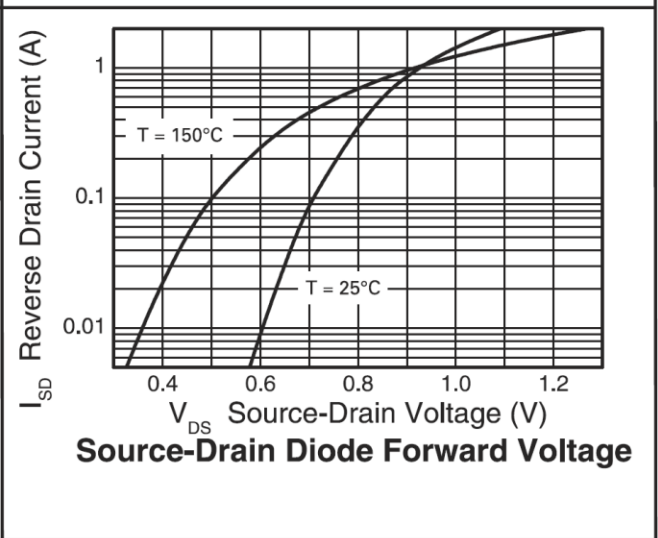
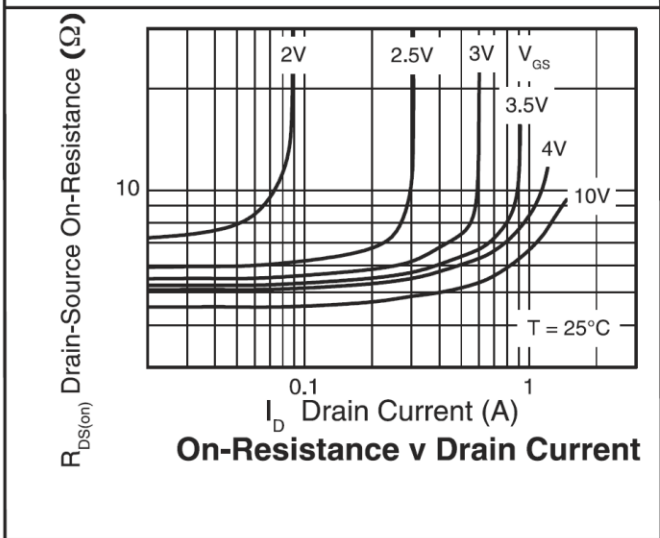
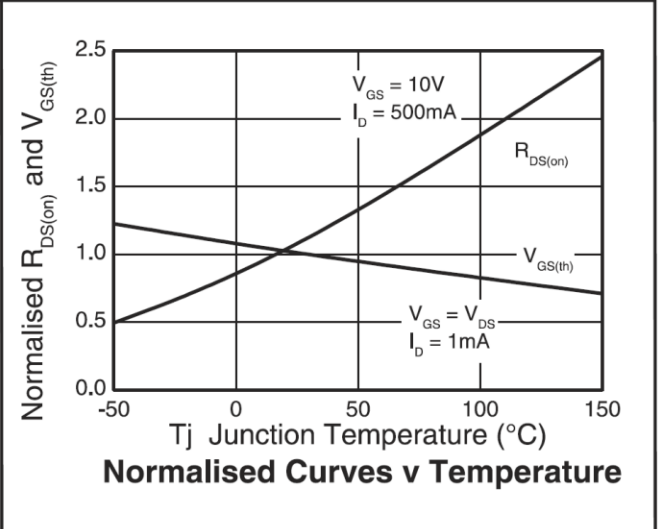
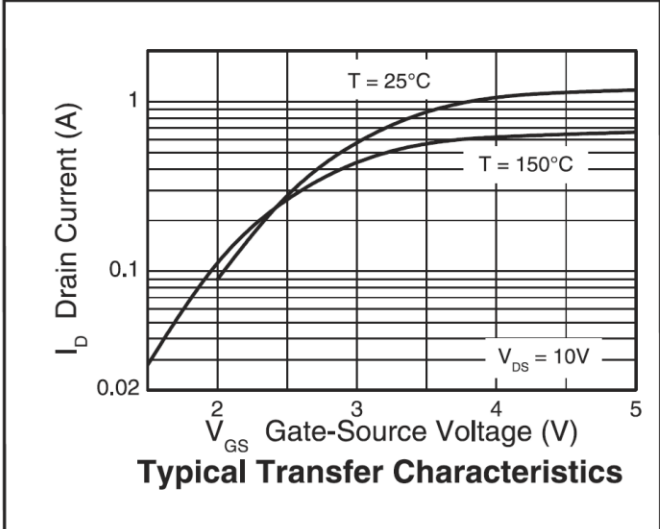
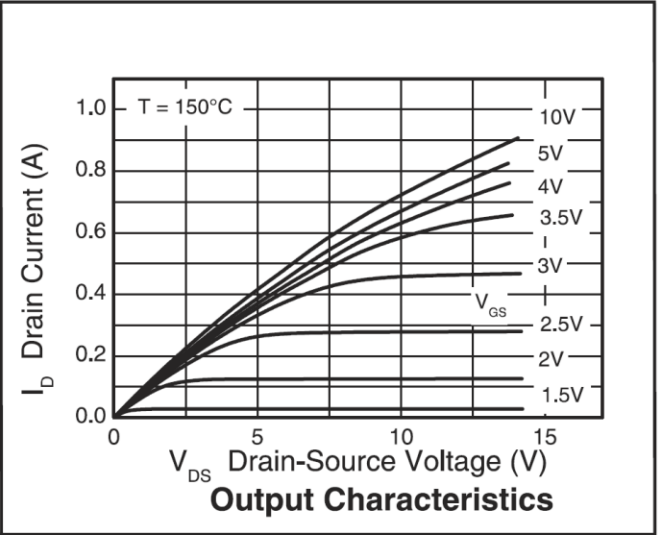
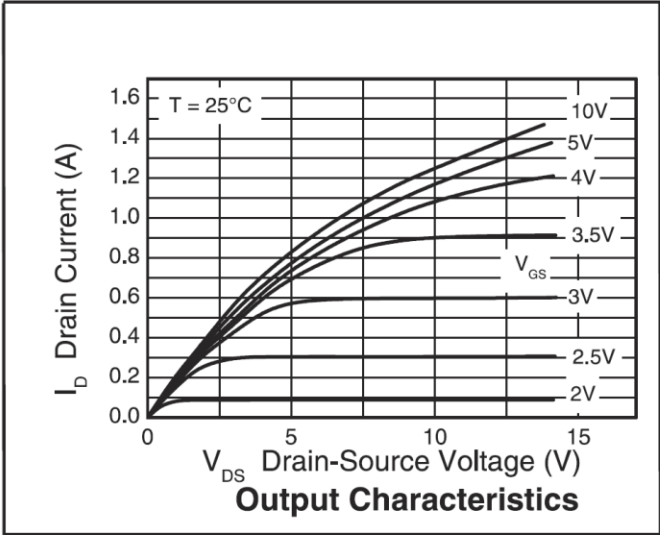

Typical Characteristics (continued)

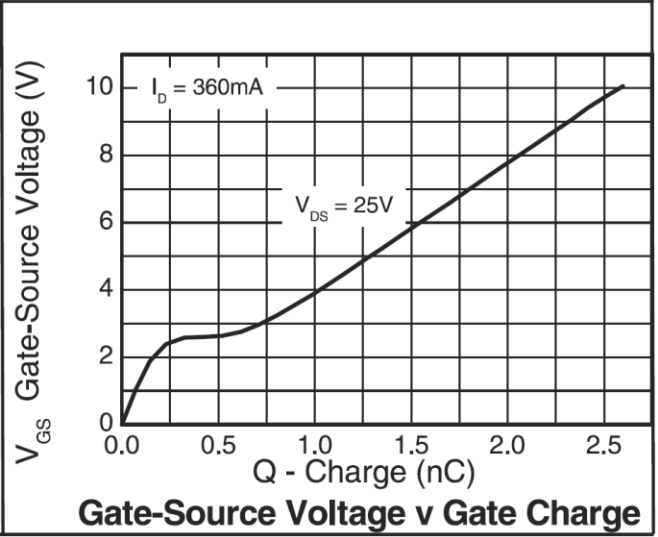
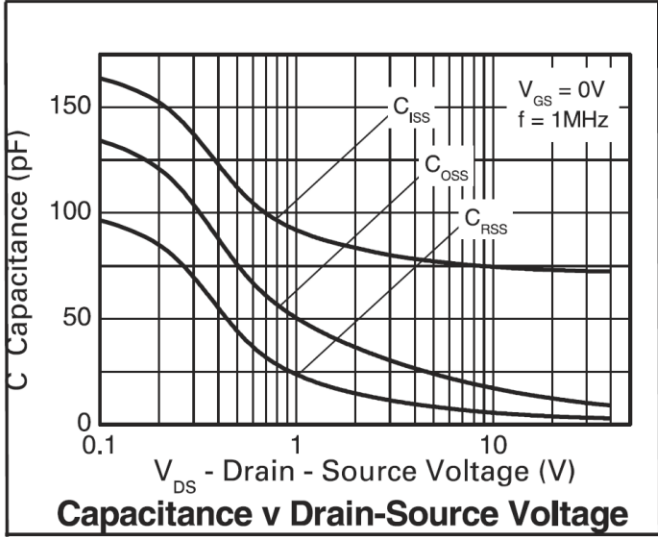

Test Circuits

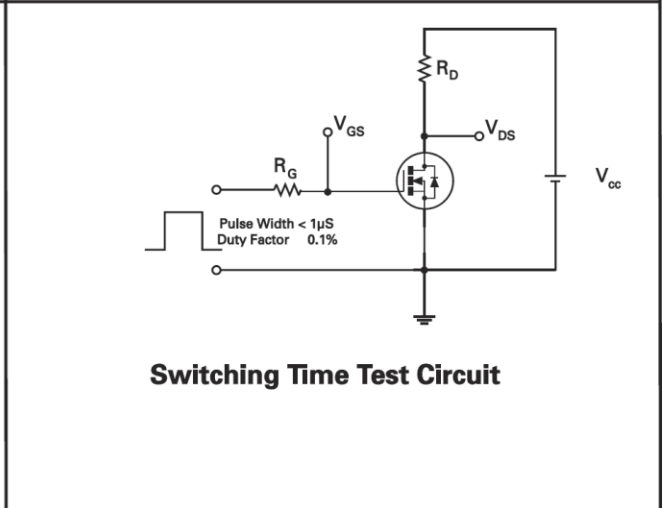
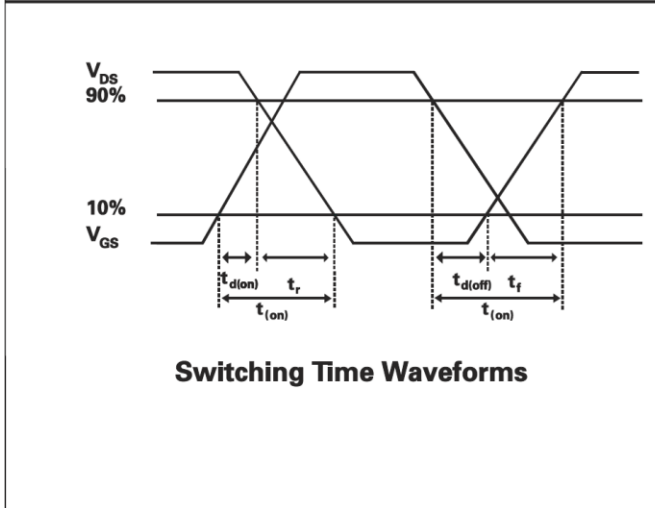
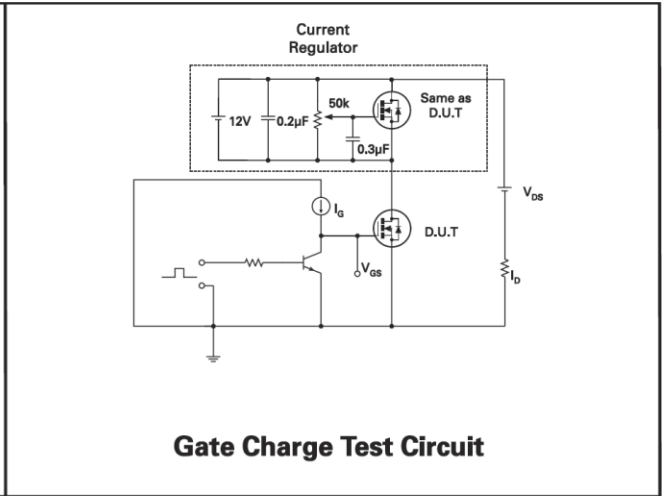
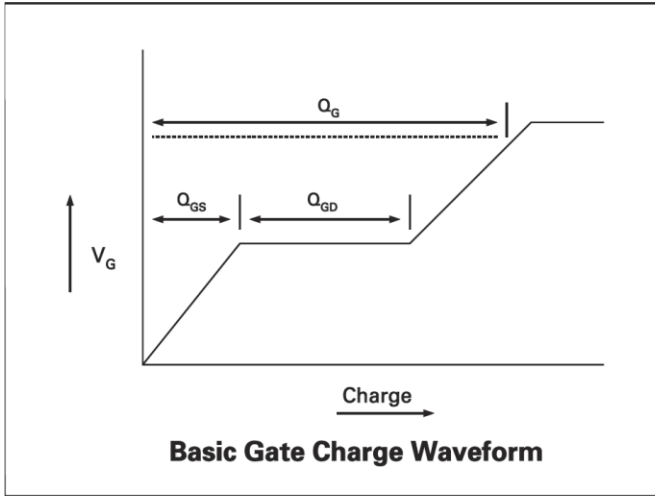

Package Outline Dimensions

Please see <http://www.diodes.com/package-outlines.html> for the latest version.

SOT26

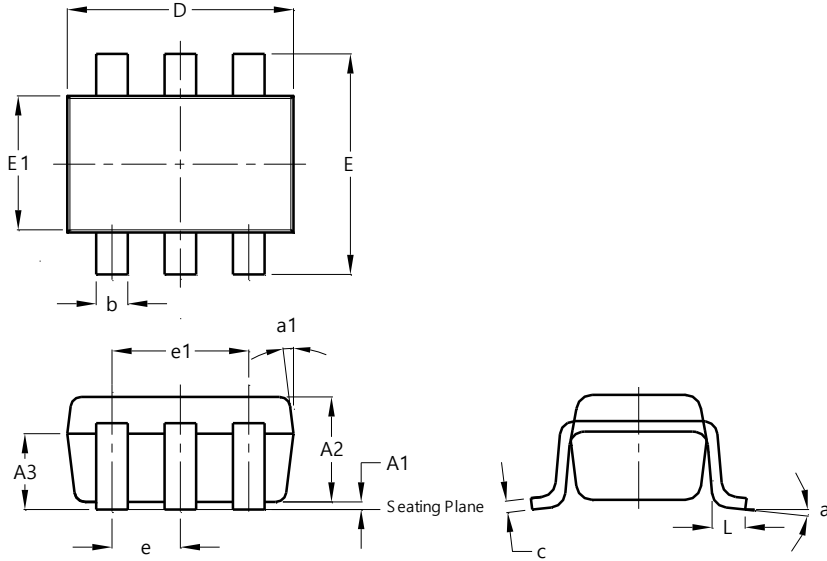

SOT26			
Dim	Min	Max	Typ
A1	0.013	0.10	0.05
A2	1.00	1.30	1.10
A3	0.70	0.80	0.75
b	0.35	0.50	0.38
c	0.10	0.20	0.15
D	2.90	3.10	3.00
e	-	-	0.95
e1	-	-	1.90
E	2.70	3.00	2.80
E1	1.50	1.70	1.60
L	0.35	0.55	0.40
a	-	-	8°
a1	-	-	7°
All Dimensions in mm			

Suggested Pad Layout

Please see <http://www.diodes.com/package-outlines.html> for the latest version.

SOT26

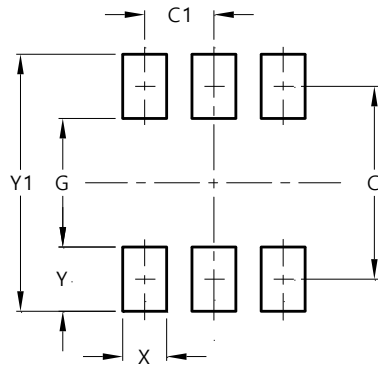

Dimensions	Value (in mm)
C	2.40
C1	0.95
G	1.60
X	0.55
Y	0.80
Y1	3.20

IMPORTANT NOTICE

1. DIODES INCORPORATED (Diodes) AND ITS SUBSIDIARIES MAKE NO WARRANTY OF ANY KIND, EXPRESS OR IMPLIED, WITH REGARDS TO ANY INFORMATION CONTAINED IN THIS DOCUMENT, INCLUDING, BUT NOT LIMITED TO, THE IMPLIED WARRANTIES OF MERCHANTABILITY, FITNESS FOR A PARTICULAR PURPOSE OR NON-INFRINGEMENT OF THIRD PARTY INTELLECTUAL PROPERTY RIGHTS (AND THEIR EQUIVALENTS UNDER THE LAWS OF ANY JURISDICTION).
2. The Information contained herein is for informational purpose only and is provided only to illustrate the operation of Diodes' products described herein and application examples. Diodes does not assume any liability arising out of the application or use of this document or any product described herein. This document is intended for skilled and technically trained engineering customers and users who design with Diodes' products. Diodes' products may be used to facilitate safety-related applications; however, in all instances customers and users are responsible for (a) selecting the appropriate Diodes products for their applications, (b) evaluating the suitability of Diodes' products for their intended applications, (c) ensuring their applications, which incorporate Diodes' products, comply the applicable legal and regulatory requirements as well as safety and functional-safety related standards, and (d) ensuring they design with appropriate safeguards (including testing, validation, quality control techniques, redundancy, malfunction prevention, and appropriate treatment for aging degradation) to minimize the risks associated with their applications.
3. Diodes assumes no liability for any application-related information, support, assistance or feedback that may be provided by Diodes from time to time. Any customer or user of this document or products described herein will assume all risks and liabilities associated with such use, and will hold Diodes and all companies whose products are represented herein or on Diodes' websites, harmless against all damages and liabilities.
4. Products described herein may be covered by one or more United States, international or foreign patents and pending patent applications. Product names and markings noted herein may also be covered by one or more United States, international or foreign trademarks and trademark applications. Diodes does not convey any license under any of its intellectual property rights or the rights of any third parties (including third parties whose products and services may be described in this document or on Diodes' website) under this document.
5. Diodes' products are provided subject to Diodes' Standard Terms and Conditions of Sale (<https://www.diodes.com/about/company/terms-and-conditions/terms-and-conditions-of-sales/>) or other applicable terms. This document does not alter or expand the applicable warranties provided by Diodes. Diodes does not warrant or accept any liability whatsoever in respect of any products purchased through unauthorized sales channel.
6. Diodes' products and technology may not be used for or incorporated into any products or systems whose manufacture, use or sale is prohibited under any applicable laws and regulations. Should customers or users use Diodes' products in contravention of any applicable laws or regulations, or for any unintended or unauthorized application, customers and users will (a) be solely responsible for any damages, losses or penalties arising in connection therewith or as a result thereof, and (b) indemnify and hold Diodes and its representatives and agents harmless against any and all claims, damages, expenses, and attorney fees arising out of, directly or indirectly, any claim relating to any noncompliance with the applicable laws and regulations, as well as any unintended or unauthorized application.
7. While efforts have been made to ensure the information contained in this document is accurate, complete and current, it may contain technical inaccuracies, omissions and typographical errors. Diodes does not warrant that information contained in this document is error-free and Diodes is under no obligation to update or otherwise correct this information. Notwithstanding the foregoing, Diodes reserves the right to make modifications, enhancements, improvements, corrections or other changes without further notice to this document and any product described herein. This document is written in English but may be translated into multiple languages for reference. Only the English version of this document is the final and determinative format released by Diodes.
8. Any unauthorized copying, modification, distribution, transmission, display or other use of this document (or any portion hereof) is prohibited. Diodes assumes no responsibility for any losses incurred by the customers or users or any third parties arising from any such unauthorized use.
9. This Notice may be periodically updated with the most recent version available at <https://www.diodes.com/about/company/terms-and-conditions/important-notice>

The Diodes logo is a registered trademark of Diodes Incorporated in the United States and other countries.
All other trademarks are the property of their respective owners.
© 2024 Diodes Incorporated. All Rights Reserved.

www.diodes.com

Looking for pricing, stock, or lifecycle information?

Click below to explore more details on WIN SOURCE:

- ⊖ [View ZVN4525E6TA on WIN SOURCE](#)
- ⊖ [Diodes Incorporated Information](#)

Optimize Your Supply Chain with WIN SOURCE Solutions

- ✓ Global Sourcing Solution
- ✓ Obsolete Management
- ✓ Cost Control Management
- ✓ Shortage Management
- ✓ Alternative Solution
- ✓ Excess Inventory Management