



**THE DATASHEET OF
ZXRE060AET5TA**



Description

The ZXRE060 is a 5-terminal adjustable shunt regulator offering excellent temperature stability and output handling capability. The ZXRE060 simplifies the design of isolated low voltage DC-DC regulators. With its low 0.6V FB pin, it can control the regulation of rails as low as 0.6V. This makes it ideal for state of the art microprocessor/DSP and PLD core voltage POL converters.

The device open-collector output can operate from 0.2V to 18V and regulated output voltage can be set by selection of two external divider resistors.

Separating the input from the open collector output enables the ZXRE060 to be used to make low-cost low drop-out regulators operating at low input voltages.

The ZXRE060 is available in two grades with initial tolerances of 0.5% and 1% for the A and standard grades respectively. It is available in space saving low profile 5 pin SC70-5/SOT353, thin TSOT23-5 and very small DFN1520H4-6 packages.

The ZXRE060 in TSOT23-5 has its OUT, GND and FB pins matching the Cathode, Anode and reference pins of the TL432 and TLV431 in SOT23-3, thereby facilitating simple upgrade paths.

Features

- Low Reference Voltage ($V_{FB} = 0.6V$)
- -40 to +125°C Temperature Range
- Reference Voltage Tolerance at +25°C
 - 0.5% ZXRE060A
 - 1% ZXRE060
- Typical Temperature Drift
 - <4mV (0°C to +70°C)
 - <6mV (-40°C to +85°C)
 - <12mV (-40°C to +125°C)
- 0.2V to 18V Open-collector Output
- High Power Supply Rejection
 - >45dB at 300kHz
- **Totally Lead-Free & Fully RoHS Compliant (Notes 1 & 2)**
- **Halogen and Antimony Free. "Green" Device (Note 3)**

- Notes:
1. No purposely added lead. Fully EU Directive 2002/95/EC (RoHS), 2011/65/EU (RoHS 2) & 2015/863/EU (RoHS 3) compliant.
 2. See <https://www.diodes.com/quality/lead-free/> for more information about Diodes Incorporated's definitions of Halogen- and Antimony-free, "Green" and Lead-free.
 3. Halogen- and Antimony-free "Green" products are defined as those which contain <900ppm bromine, <900ppm chlorine (<1500ppm total Br + Cl) and <1000ppm antimony compounds.

Pin Assignments

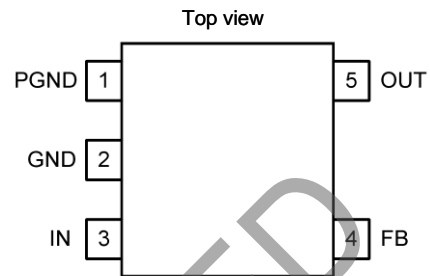

SC70-5/SOT353, TSOT23-5

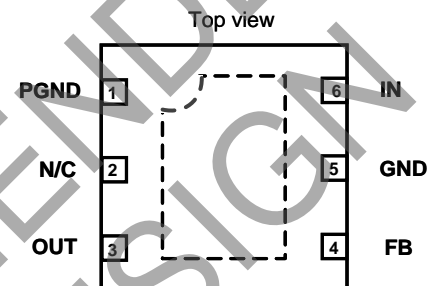

Exposed flag floating or connect to GND

DFN1520H4-6

Applications

- Isolated DC-DC Converters
- Core Voltage POL
- Low Voltage Low-Dropout Linear Regulators
- Shunt Regulators
- Adjustable Voltage Reference

Typical Application Circuit

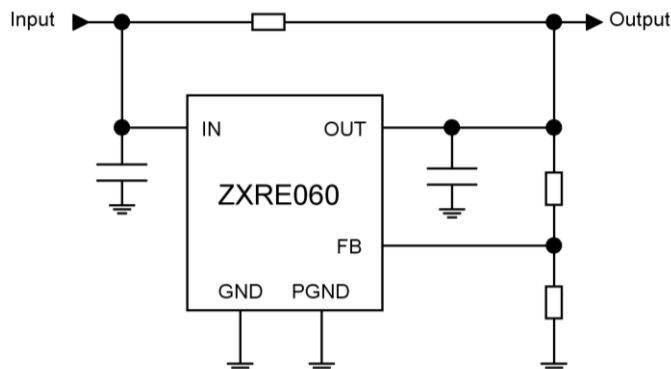

Pin Description

Pin Number (SC70-5 /SOT353, TSOT23-5)	Pin Number (DFN1520H4-6)	Pin Name	Function
1	1	PGND	Power Ground: Ground return for emitter of output transistor: Connect PGND and GND together.
—	2	N/C	No connection
5	3	OUT	Output. Connect a capacitor close to device between OUT and GND. See the Applications Information section.
4	4	FB	Feedback Input. Regulates to 600mV nominal.
2	5	GND	Analog Ground: Ground return for reference and amplifier: Connect GND and PGND together.
3	6	IN	Supply Input. Connect a 0.1µF ceramic capacitor close to the device from IN to GND.
—	Flag	—	Floating or connect to GND

Function Block Diagram

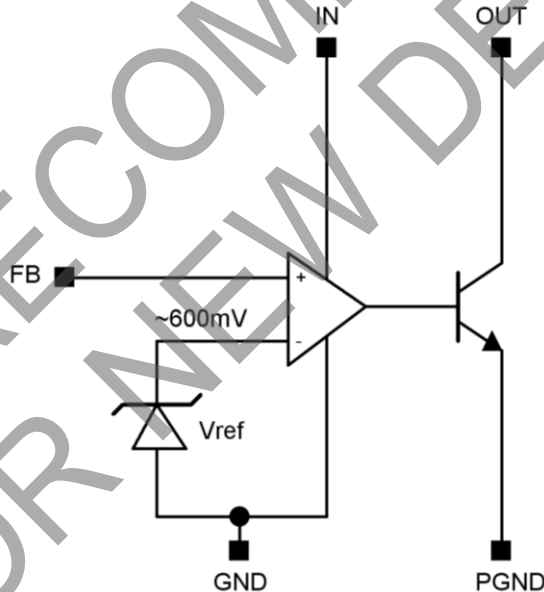

The ZXRE060 differs from most other shunt regulators in that it has separate input and output pins and a low voltage reference. This enables it to regulate rails down to 600mV and makes the part ideal for isolated power supply applications that use opto-couplers in the feedback loop and where the open-collector output is required to operate down to voltages as low as 200mV.

The wide input voltage range of 2V to 18V and output voltage range of 0.2V to 18V enables the ZXRE060 to be powered from an auxiliary rail, while controlling a master rail which is above the auxiliary rail voltage, or below the minimum V_{IN} voltage. This allows it to operate as a low-dropout voltage regulator for microprocessor/DSP/PLD cores.

As with other shunt regulators (and shunt references), the ZXRE060 compares its internal amplifier FB pin to a high accuracy internal reference; if FB is below the reference then OUT turns off, but if FB is above the reference then OUT sinks current – up to a maximum of 15mA.

Absolute Maximum Ratings (Voltages to GND Unless Otherwise Stated)

Symbol	Parameter	Rating	Unit
V _{IN}	IN Voltage relative to GND	20	V
V _{OUT}	OUT Voltage relative to GND	20	V
V _{FB}	FB Voltage relative to GND	20	V
P _{GND}	PGND Voltage relative to GND	-0.3 to +0.3	V
I _{OUT}	OUT Pin Current	20	mA
T _J	Operating Junction Temperature	-40 to +150	°C
T _{ST}	Storage Temperature	55 to +150	°C

These are stress ratings only. Operation outside the absolute maximum ratings may cause device failure. Operation at the absolute maximum rating for extended periods may reduce device reliability.

Semiconductor devices are ESD sensitive and may be damaged by exposure to ESD events. Suitable ESD precautions should be taken when handling and transporting these devices.

Package Thermal Data

Package	θ_{JA}	P _{DIS} T _A = +25°C, T _J = +150°C
SC70-5/SOT353	400°C/W	310mW
TSOT23-5	250°C/W	500mW
DFN1520H4-6	TBD	TBD

Recommended Operating Conditions

Symbol	Parameter	Min	Max	Unit
V _{IN}	IN Voltage Range (0 to +125°C)	2	18	V
V _{IN}	IN Voltage Range (-40 to 0°C)	2.2	18	
V _{OUT}	OUT Voltage Range	0.2	18	mA
I _{OUT}	OUT Pin Current	0.3	15	
T _A	Operating Ambient Temperature Range	-40	+125	°C

Electrical Characteristics (@ $T_A = +25^\circ\text{C}$, $V_{IN} = 3.3\text{V}$, $V_{OUT} = V_{FB}$, $I_{OUT} = 5\text{mA}$, unless otherwise stated. (Note 4))

Symbol	Parameter	Conditions		Min	Typ	Max	Unit	
V_{FB}	Feedback Voltage	—		ZXRE060A	0.597	0.6	0.603	V
		—		ZXRE060	0.594	0.6	0.606	
		$T_A = 0^\circ\text{C to } +85^\circ\text{C}$		ZXRE060A	0.595	—	0.605	
				ZXRE060	0.592	—	0.608	
		$T_A = -40^\circ\text{C to } +85^\circ\text{C}$		ZXRE060A	0.594	—	0.606	
				ZXRE060	0.591	—	0.609	
		$T_A = -40^\circ\text{C to } +125^\circ\text{C}$		ZXRE060A	0.593	—	0.607	
				ZXRE060	0.590	—	0.610	
FB_{LOAD}	Feedback Pin Load Regulation	$I_{OUT} = 1 \text{ to } 15\text{mA}$		—	3.8	6	mV	
		$T_A = -40 \text{ to } +125^\circ\text{C}$		—	—	10		
FB_{LINE}	Feedback Pin Line Regulation	$V_{IN} = 2\text{V to } 18\text{V}$		—	0.1	1	mV	
		$V_{IN} = 2.2\text{V to } 18\text{V}$		$T_A = -40 \text{ to } +125^\circ\text{C}$		—		1.5
FB_{OVR}	Output Voltage Regulation	$V_{OUT} = 0.2\text{V to } 18\text{V}$, $I_{OUT} = 1\text{mA}$		—	—	1	mV	
				$T_A = -40 \text{ to } +125^\circ\text{C}$		—		1.5
I_{FB}	FB Input Bias Current	$V_{IN} = 18\text{V}$		—	-45	—	nA	
				$T_A = -40 \text{ to } +125^\circ\text{C}$		-200		0
I_{IN}	Input Current	$V_{IN} = 2\text{V to } 18\text{V}$	$I_{OUT} = 0.3\text{mA}$	—	0.35	0.7	mA	
		$V_{IN} = 2.2\text{V to } 18\text{V}$		$T_A = -40 \text{ to } +125^\circ\text{C}$		—		1
		$V_{IN} = 2\text{V to } 18\text{V}$	$I_{OUT} = 10\text{mA}$	—	0.48	1	mA	
		$V_{IN} = 2.2\text{V to } 18\text{V}$		$T_A = -40 \text{ to } +125^\circ\text{C}$		—		1.5
$I_{OUT(LK)}$	OUT Leakage Current	$V_{IN} = 18\text{V}$, $V_{OUT} = 18\text{V}$, $V_{FB} = 0\text{V}$		—	—	0.1	μA	
		$T_A = +125^\circ\text{C}$		—	—	1		
Z_{OUT}	Dynamic Output Impedance	$I_{OUT} = 1 \text{ to } 15\text{mA}$		—	0.25	0.4	Ω	
		$f < 1\text{kHz}$		$T_A = -40 \text{ to } +125^\circ\text{C}$		—		0.6
PSRR	Power Supply Rejection Ratio	$f = 300\text{kHz}$ $V_{AC} = 0.3V_{PP}$		—	>45	—	dB	
BW	Amplifier Unity Gain Frequency	Ref: Figure 1		—	600	—	kHz	
G	Amplifier Transconductance			—	5000	—	mA/V	

Note: 4. Production testing of the device is performed at $+25^\circ\text{C}$. Functional operation of the device and parameters specified over the operating temperature range are guaranteed by design, characterisation and process control.

Typical Characteristics

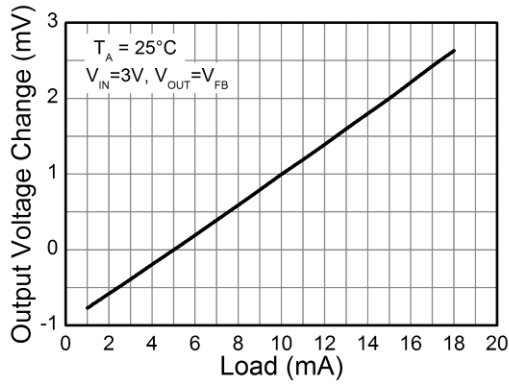

Load Regulation

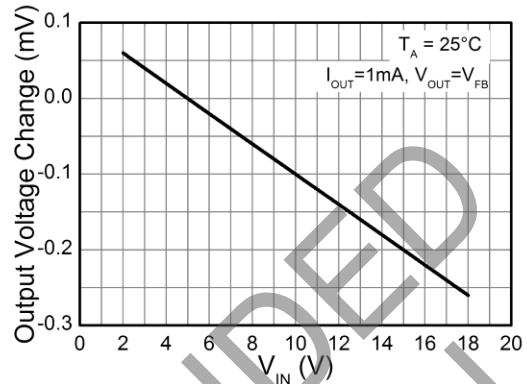

Line Regulation

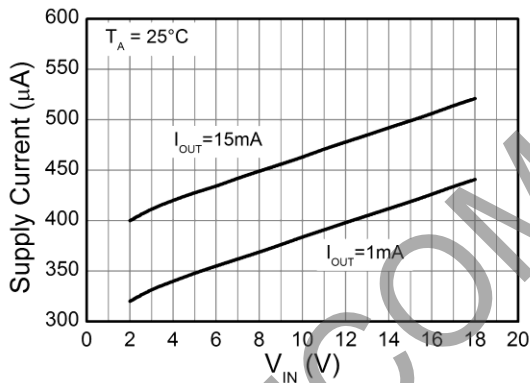

Supply Current vs Input Voltage

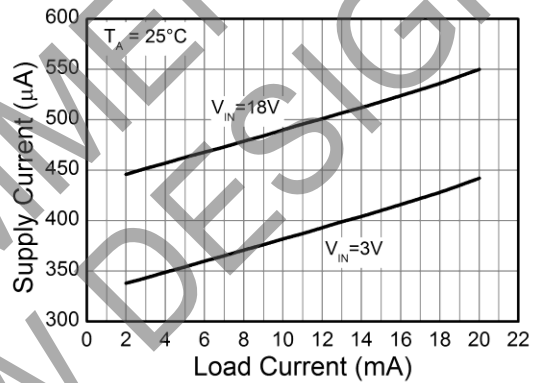

Supply Current vs Load Current

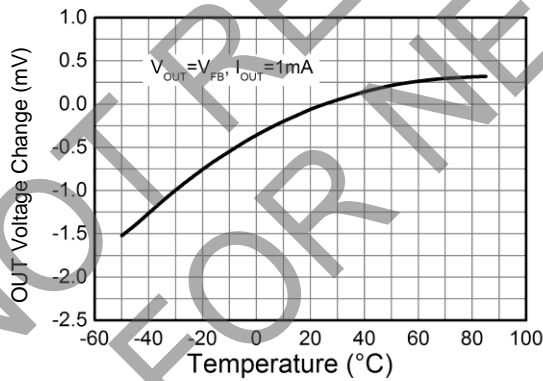

OUT Voltage Change with Temperature

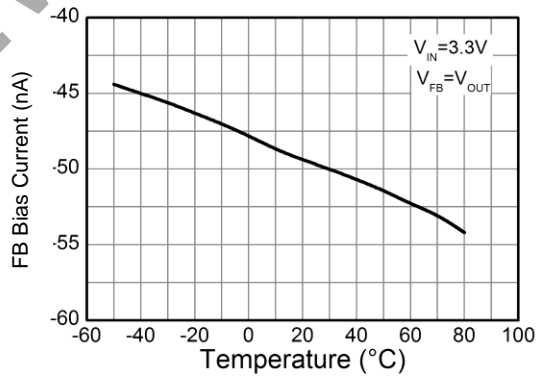

FB Bias Current vs Temperature

Typical Operating Conditions (Cont.)

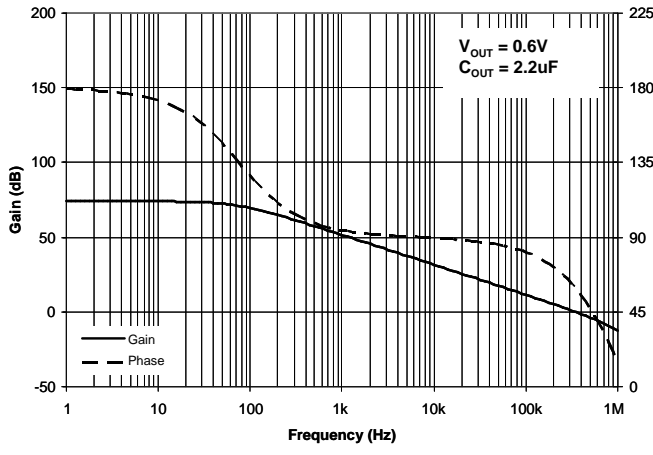

Gain and Phase vs Frequency, $V_{OUT}=0.6V$

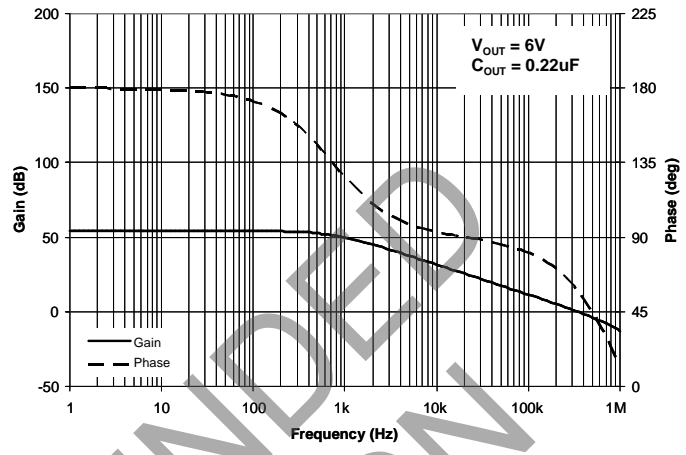

Gain and Phase vs Frequency, $V_{OUT}=6V$

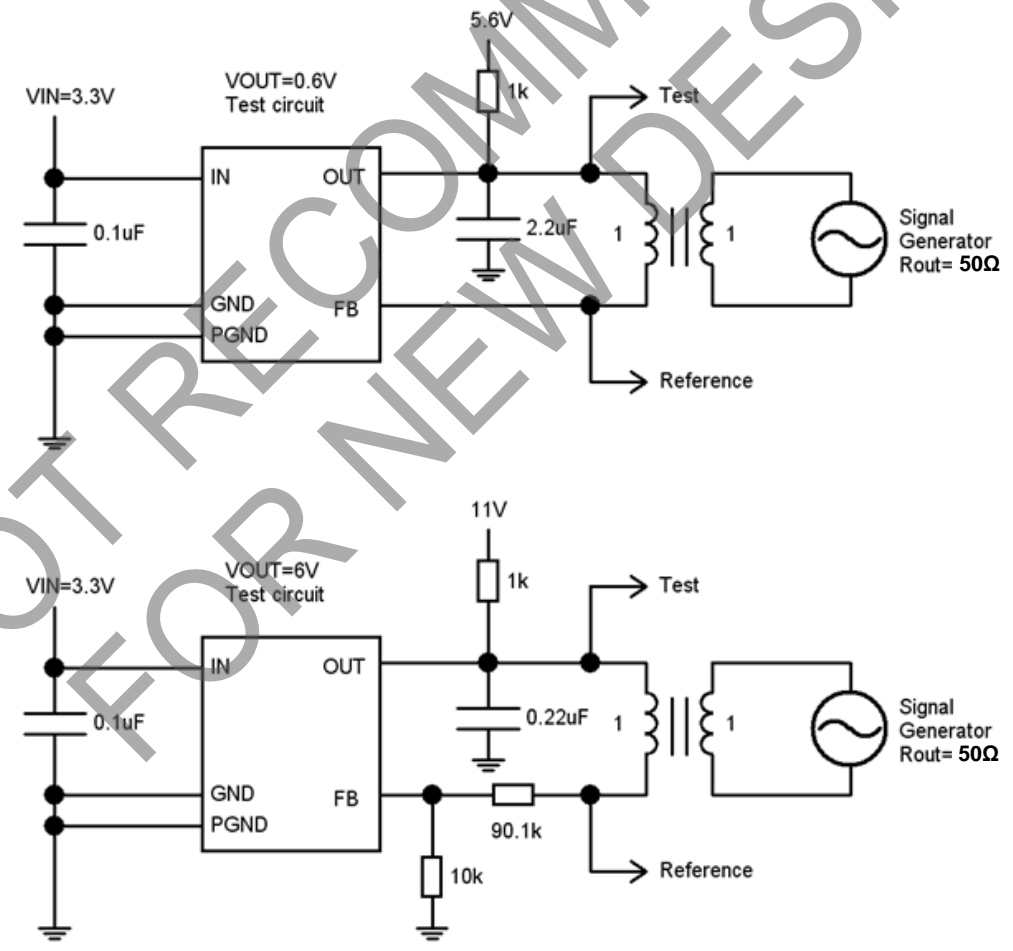

Figure 1. Test Circuits for Gain and Phase Plots

Application Information

The following show some typical application examples for the ZXRE060. It is recommended to include the compensation capacitor C2 to guarantee stability. C2 may range in value from 0.1µF to 10µF depending on the application. The time constant formed by C2 and R3 should be greater than 1ms multiplied by the feedback factor $R2/(R1 + R2)$.

Both C1 and C2 should be as close to the ZXRE060 as possible and connected to it with the shortest possible track. In the case of Figure 8 and Figure 9, it means the opto-coupler will have to be carefully positioned to enable this.

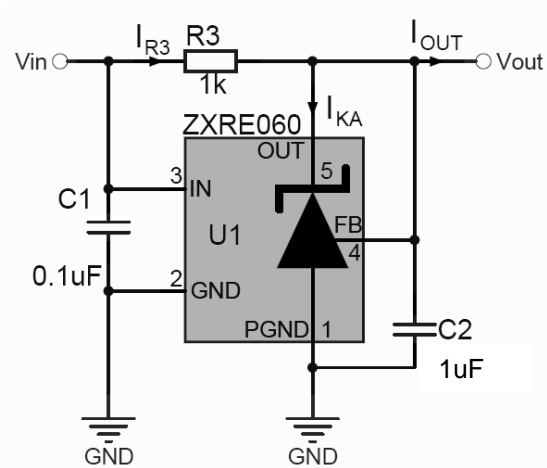

Figure 2. 0.6V Shunt Regulator
 $V_{OUT} = V_{REF}$

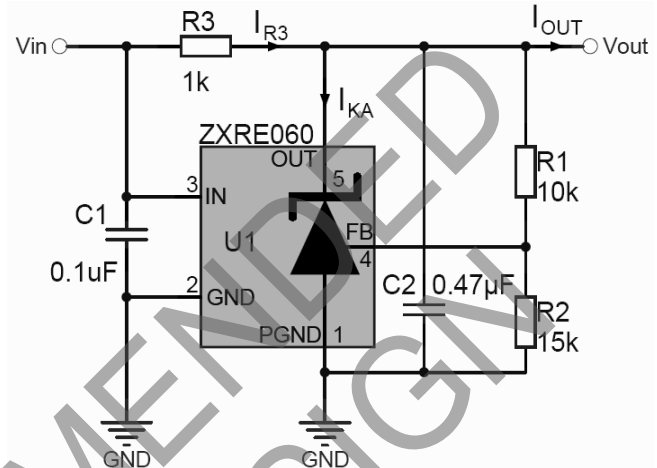

Figure 3. 1.0V Shunt Regulator
 $V_{OUT} = V_{REF} \left(1 + \frac{R1}{R2}\right)$

$$R3 = \frac{V_{IN} - V_{OUT}}{I_{R3}}$$

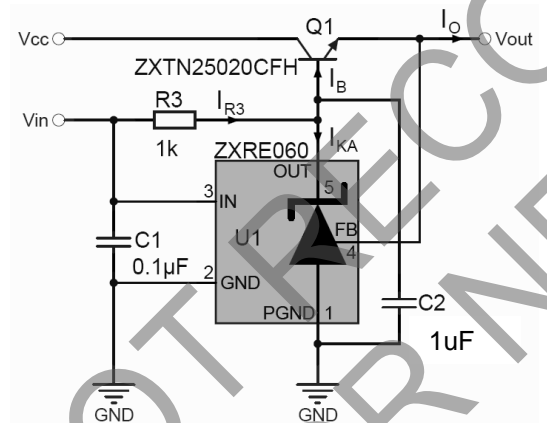

Figure 4. 0.6V series LDO regulator
 $V_{OUT} = V_{REF}$

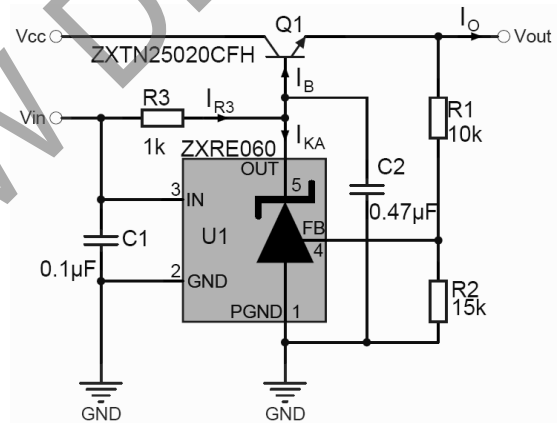
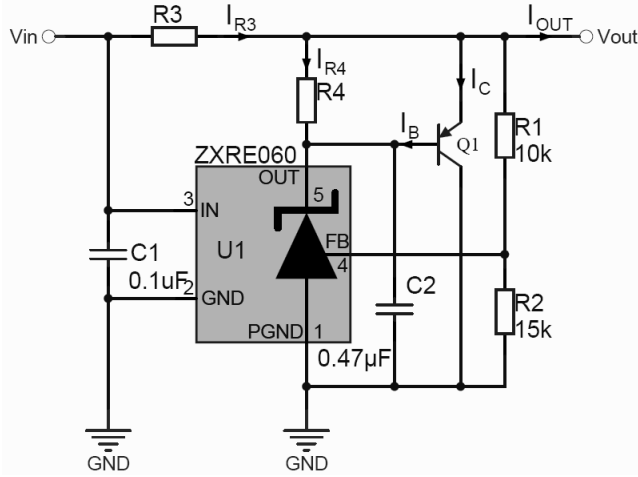

Figure 5. 1.0V series LDO regulator
 $V_{OUT} = V_{REF} \left(1 + \frac{R1}{R2}\right)$

Design Guides

- Determine I_{OUT} and choose a suitable transistor taking power dissipation into consideration.
- Determine I_B from $I_B = \frac{I_{OUT(max)}}{(hFE(min) + 1)}$
- Determine I_{R3} from $I_{R3} \geq I_B + I_{KA(min)}$. The design of the ZXRE060 effectively means there is no $I_{KA(min)}$ limitation as in conventional references. There is only an output leakage current which is a maximum of 1µA. Nevertheless, it is necessary to determine an $I_{KA(min)}$ to ensure that the device operates within its linear range at all times. $I_{KA(min)} \geq 10\mu A$ should be adequate for this.
- Determine R3 from $R3 = \frac{V_{IN} - (V_{OUT} + V_{BE})}{I_{R3}}$.
- Although unlikely to be a problem, ensure that $I_{R3} \leq 15mA$.

Application Information (Cont.)



$$V_{OUT} = V_{REF} \left(1 + \frac{R1}{R2} \right)$$

$$(V_{OUT} \geq 0.2V + V_{BE})$$

$$R3 = \frac{V_{IN} - V_{OUT}}{I_{R3}}$$

Figure 6. 1V Current-boosted Shunt Regulator

Design Guides

1. Determine I_{OUT} and choose a suitable transistor taking power dissipation into consideration.
2. Determine I_B from $I_B = \frac{I_{OUT(max)}}{(hFE(min) + 1)}$
3. Determine I_{R3} from $I_{R3} = I_{OUT(max)}$
4. Determine $R3$ from $R3 = \frac{V_{IN} - V_{OUT}}{I_{R3}}$
5. It is best to let the ZXRE060 supply as much current as it can before bringing Q1 into conduction. Not only does this minimise the strain on Q1, it also guarantees the most stable operation. Choose a nominal value between 10mA and <15mA for this current, I_{R4} .
6. Calculate $R4$ from $R4 = \frac{V_{BE}}{I_{R4}}$

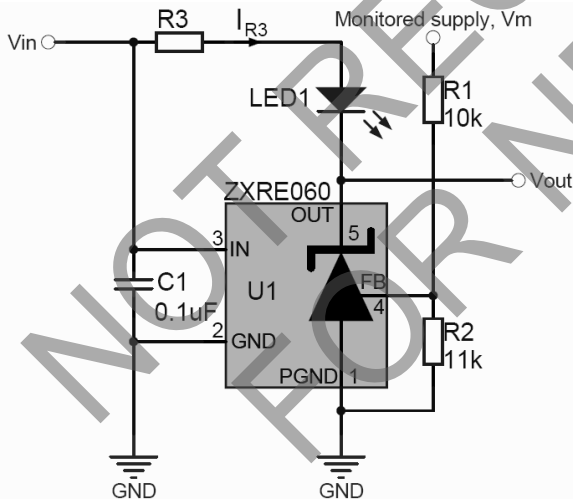

V_{OUT} goes low and LED is lit when monitored supply

$$V_M > V_{REF} \left(1 + \frac{R1}{R2} \right)$$

$$R3 = \frac{V_{IN} - (V_F + 0.2)}{I_{R3}}$$

$$15mA \geq I_{R3} \leq I_{F(MAX)}$$

V_F and I_F are forward voltage drop and current of LED1.

Figure 7. 1.15V Over-voltage Indicator

Application Information (Cont.)

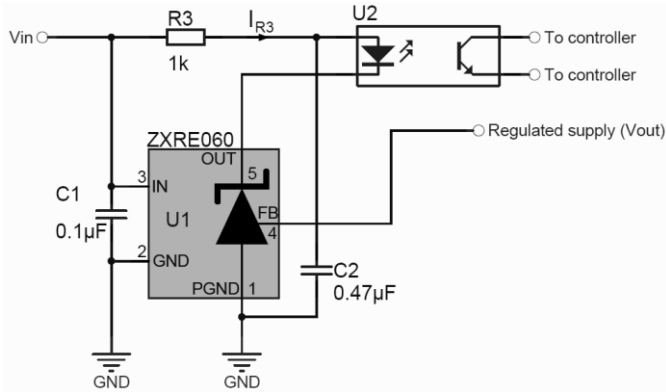

Figure 8. Opto-isolated 0.6V Shunt Regulator

$$V_{OUT} = V_{REF}$$

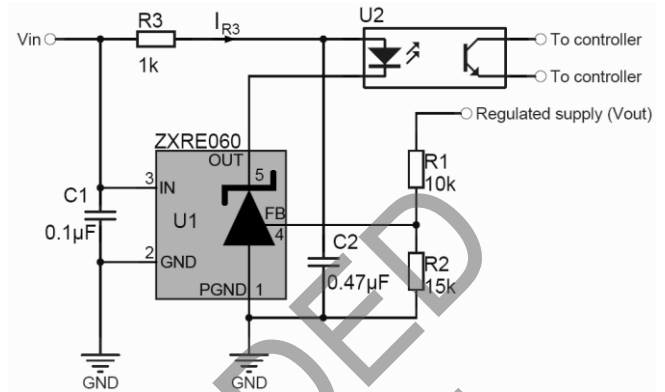

Figure 9. Opto-isolated 1.0V Shunt Regulator

$$V_{OUT} = V_{REF} \left(1 + \frac{R1}{R2} \right)$$

$$R3 = \frac{V_{IN} - (V_F + 0.2)}{I_{R3}}$$

$$15\text{mA} \geq I_{R3} \leq I_F(\text{MAX})$$

V_F and I_F are forward voltage drop and forward current respectively for the optocoupler LED.

More applications information is available in the following publications which can be found on Diodes Incorporated's web site.

- AN58 - Designing with Diodes Incorporated's References – *Shunt Regulation*
- AN59 - Designing with Diodes Incorporated's References – *Series Regulation*
- AN60 - Designing with Diodes Incorporated's References – *Fixed Regulators and Opto-Isolation*
- AN61 - Designing with Diodes Incorporated's References – *Extending the operating voltage range*
- AN62 - Designing with Diodes Incorporated's References – *Other Applications*
- AN63 - Designing with Diodes Incorporated's References – *ZXRE060 Low Voltage Regulator*

NOT RECOMMENDED FOR NEW DESIGN

Ordering Information

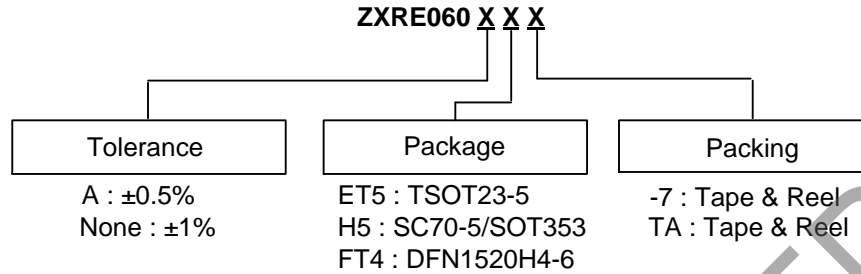

Tol.	Order Code	Package	Identification Code	Reel Size	Tape Width	Quantity/Reel
0.5%	ZXRE060AET5TA	TSOT23-5	S6A	7", 180mm	8mm	3000
	ZXRE060AH5TA	SC70-5/SOT353	S6A	7", 180mm	8mm	3000
	ZXRE060AFT4-7	DFN1520H4-6	S6A	7", 180mm	8mm	3000
1%	ZXRE060ET5TA	TSOT23-5	S06	7", 180mm	8mm	3000
	ZXRE060H5TA	SC70-5/SOT353	S06	7", 180mm	8mm	3000
	ZXRE060FT4-7	DFN1520H4-6	S06	7", 180mm	8mm	3000

Note: 5. For packaging details, go to our website at <https://www.diodes.com/design/support/packaging/diodes-packaging/>.

Marking Information

(1) TSOT23-5, SC70-5/SOT353

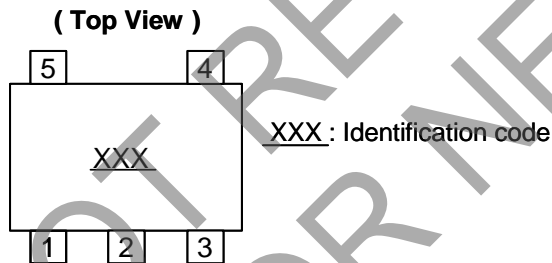

(2) DFN1520H4-6

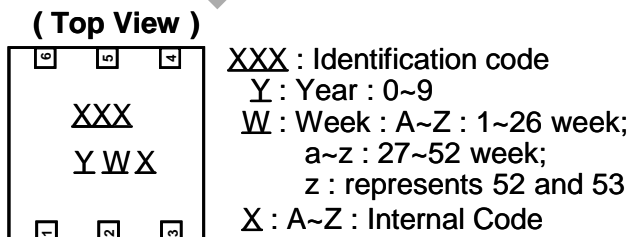

Package Outline Dimensions

(1) TSOT23-5

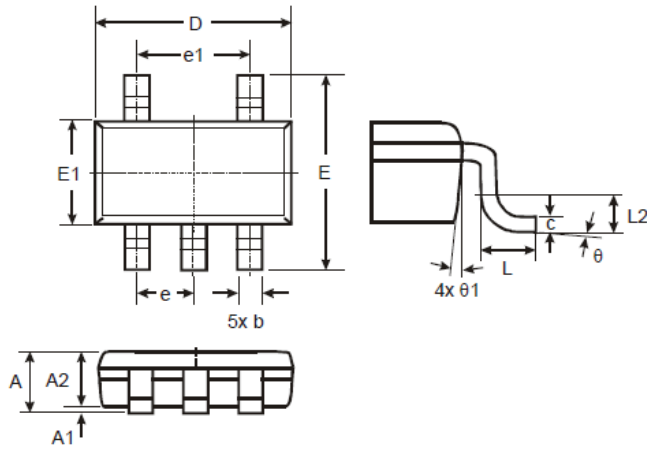

TSOT23-5			
Dim	Min	Max	Typ
A	-	1.00	-
A1	0.01	0.10	-
A2	0.84	0.90	-
D	-	-	2.90
E	-	-	2.80
E1	-	-	1.60
b	0.30	0.45	-
c	0.12	0.20	-
e	-	-	0.95
e1	-	-	1.90
L	0.30	0.50	-
L2	-	-	0.25
theta	0°	8°	4°
theta1	4°	12°	-
All Dimensions in mm			

(2) SC70-5/SOT353

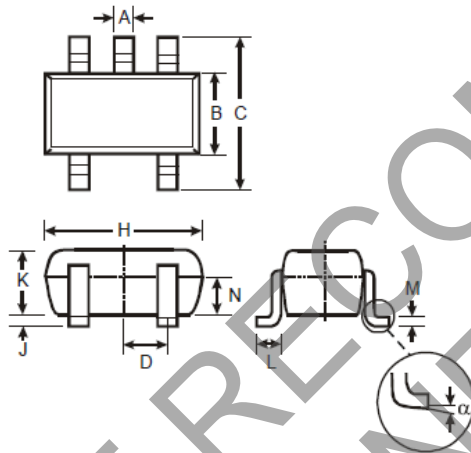

SOT-353		
Dim	Min	Max
A	0.10	0.30
B	1.15	1.35
C	2.00	2.20
D	0.65 Typ	
F	0.40	0.45
H	1.80	2.20
J	0	0.10
K	0.90	1.00
L	0.25	0.40
M	0.10	0.22
alpha	0°	8°
All Dimensions in mm		

(3) DFN1520H4-6

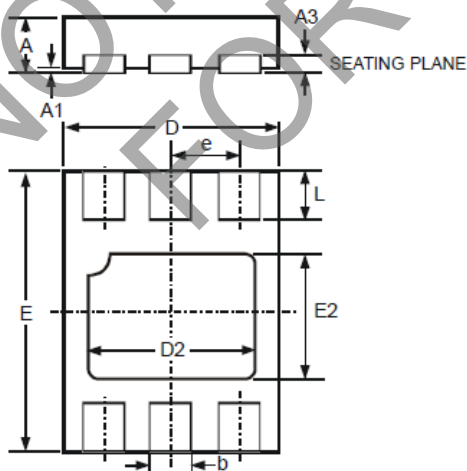

DFN1520H4-6			
Dim	Min	Max	Typ
A	-	0.40	-
A1	0	0.05	-
A3	-	-	0.13
b	0.20	0.30	-
D	1.45	1.575	-
D2	1.00	1.20	-
e	-	-	0.50
E	1.95	2.075	-
E2	0.70	0.90	-
L	0.25	0.35	-
All Dimensions in mm			

IMPORTANT NOTICE

DIODES INCORPORATED MAKES NO WARRANTY OF ANY KIND, EXPRESS OR IMPLIED, WITH REGARDS TO THIS DOCUMENT, INCLUDING, BUT NOT LIMITED TO, THE IMPLIED WARRANTIES OF MERCHANTABILITY AND FITNESS FOR A PARTICULAR PURPOSE (AND THEIR EQUIVALENTS UNDER THE LAWS OF ANY JURISDICTION).

Diodes Incorporated and its subsidiaries reserve the right to make modifications, enhancements, improvements, corrections or other changes without further notice to this document and any product described herein. Diodes Incorporated does not assume any liability arising out of the application or use of this document or any product described herein; neither does Diodes Incorporated convey any license under its patent or trademark rights, nor the rights of others. Any Customer or user of this document or products described herein in such applications shall assume all risks of such use and will agree to hold Diodes Incorporated and all the companies whose products are represented on Diodes Incorporated website, harmless against all damages.

Diodes Incorporated does not warrant or accept any liability whatsoever in respect of any products purchased through unauthorized sales channel. Should Customers purchase or use Diodes Incorporated products for any unintended or unauthorized application, Customers shall indemnify and hold Diodes Incorporated and its representatives harmless against all claims, damages, expenses, and attorney fees arising out of, directly or indirectly, any claim of personal injury or death associated with such unintended or unauthorized application.

Products described herein may be covered by one or more United States, international or foreign patents pending. Product names and markings noted herein may also be covered by one or more United States, international or foreign trademarks.

This document is written in English but may be translated into multiple languages for reference. Only the English version of this document is the final and determinative format released by Diodes Incorporated.

LIFE SUPPORT

Diodes Incorporated products are specifically not authorized for use as critical components in life support devices or systems without the express written approval of the Chief Executive Officer of Diodes Incorporated. As used herein:

A. Life support devices or systems are devices or systems which:

1. are intended to implant into the body, or
2. support or sustain life and whose failure to perform when properly used in accordance with instructions for use provided in the labeling can be reasonably expected to result in significant injury to the user.

B. A critical component is any component in a life support device or system whose failure to perform can be reasonably expected to cause the failure of the life support device or to affect its safety or effectiveness.

Customers represent that they have all necessary expertise in the safety and regulatory ramifications of their life support devices or systems, and acknowledge and agree that they are solely responsible for all legal, regulatory and safety-related requirements concerning their products and any use of Diodes Incorporated products in such safety-critical, life support devices or systems, notwithstanding any devices- or systems-related information or support that may be provided by Diodes Incorporated. Further, Customers must fully indemnify Diodes Incorporated and its representatives against any damages arising out of the use of Diodes Incorporated products in such safety-critical, life support devices or systems.

Copyright © 2018, Diodes Incorporated

www.diodes.com

Looking for pricing, stock, or lifecycle information?

Click below to explore more details on WIN SOURCE:

- ⊖ [View ZXRE060AET5TA on WIN SOURCE](#)
- ⊖ [Diodes Incorporated Information](#)

Optimize Your Supply Chain with WIN SOURCE Solutions

- ✓ Global Sourcing Solution
- ✓ Obsolete Management
- ✓ Cost Control Management
- ✓ Shortage Management
- ✓ Alternative Solution
- ✓ Excess Inventory Management