

ZXSC410 ZXSC420

VOLTAGE MODE BOOST CONVERTER

DESCRIPTION

The ZXSC410 is voltage mode boost converter in SOT23-6 package. Its excellent load and line regulation means that for the full supply range from lithium Ion cells, the output voltage will typically change by less than 1%. Using high efficiency Zetex switching transistors allow output voltages of tens of volts depending on the selected transistor. The ZXSC420 includes a battery low indicator. This operates by indicating when the converter is no longer able to maintain the regulated output voltage rather than setting a preset threshold, thereby making it suitable for various battery options and load currents.

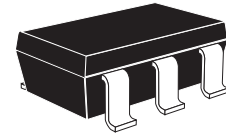

SOT23-6

FEATURES

- 1.65V to 8V supply range
- Typical output regulation of $\pm 1\%$
- Over 85% typical efficiency
- Output currents up to 300mA
- 4.5 μ A typical shutdown current ZXSC410
- End of regulation output ZXSC420

ORDERING INFORMATION

DEVICE	REEL SIZE	TAPE WIDTH	QUANTITY PER REEL
ZXSC410E6TA	7"	8mm	3000 units
ZXSC420E6TA	7"	8mm	3000 units

APPLICATIONS

- System power for battery portable products
- LCD bias
- Local voltage conversion

TYPICAL APPLICATIONS DIAGRAM

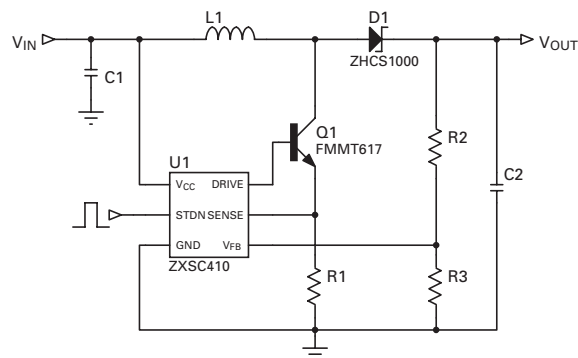

DEVICE MARKING

- C410 ZXSC410
- C420 ZXSC420

ZXSC410 ZXSC420

ABSOLUTE MAXIMUM RATINGS

V _{CC}	-0.3V to +10V	
DRIVE	-0.3V to V _{CC} + 0.3V	
EOR	-0.3V to V _{CC} + 0.3V	* (ZXSC420 only)
STDN	-0.3V to The lower of (+5.0V) or (V _{CC} + 0.3V)	* (ZXSC410 only)
V _{FB} , SENSE	-0.3V to The lower of (+5.0V) or (V _{CC} + 0.3V)	
Operating Temp.	-40°C to +85°C	
Storage Temp.	-55°C to +125°C	
Power Dissipation	450mW	

ELECTRICAL CHARACTERISTICS

Test Conditions V_{CC}= 3V, T= -40°C to 85°C unless otherwise stated.

Symbol	Parameter	Conditions	Limits			Units
			Min	Typ	Max	
Supply parameters						
V _{CC}	V _{CC} Range		1.8		8	V
I _q ¹	Quiescent Current	V _{CC} = 8V			220	μA
I _{STDN}	Shutdown Current			4.5		μA
Eff ²	Efficiency	50mA > I _{OUT} > 300mA		85		%
Acc _{REF}	Reference tolerance	1.8V < V _{CC} < 8V	-3.0		3.0	%
TCO _{REF}	Reference Temp Co			0.005		%/°C
T _{DRV}	Discharge pulse width	1.8V < V _{CC} < 8V		1.7		μs
F _{OSC}	Operating Frequency				200	kHz
Input parameters						
V _{SENSE}	sense voltage		22	28	34	mV
I _{SENSE}	sense input current	V _{FB} =0V; V _{SENSE} =0V	-1	-7	-15	μA
V _{FB}	Feedback voltage	T _A = 25°C	291	300	309	mV
I _{FB} ²	Feedback input current	V _{FB} =0V; V _{SENSE} =0V	-1.2		-4.5	μA
V _{IH}	Shutdown high voltage		1.5	1	V _{CC}	V
V _{IL}	Shutdown low voltage		0		0.55	V
dV _{LN}	Line voltage regulation			0.5		%/V
Output parameters						
I _{OUT} ³	Output current	V _{IN} > 2V, V _{OUT} = V _{IN}	300			mA
I _{DRIVE}	Transistor drive current	V _{DRIVE} = 0.7V	2	3.4	5	mA
V _{DRIVE}	Transistor voltage drive	1.8V < V _{CC} < 8V	0		V _{CC} -0.4	V
C _{DRIVE}	Mosfet gate drive cpbty			300		pF
VOH _{EOR}	EOR Flag output high	I _{EOR} = -300nA	2.5		V _{CC}	V
VOL _{EOR}	EOR Flag output low	I _{EOR} = 1mA	0		1.15	V
T _{EOR}	EOR delay time	T _A = 25°C	70	195	250	μs
dI _{LD}	Load current regulation				0.01	%mA

Note

¹ Excluding gate/base drive current.

² I_{FB} is typically half of these values at 3V

³ System not device spec, including recommended transistors.



ISSUE 2 - May 2003

ZXSC410 ZXSC420

TYPICAL CHARACTERISTICS

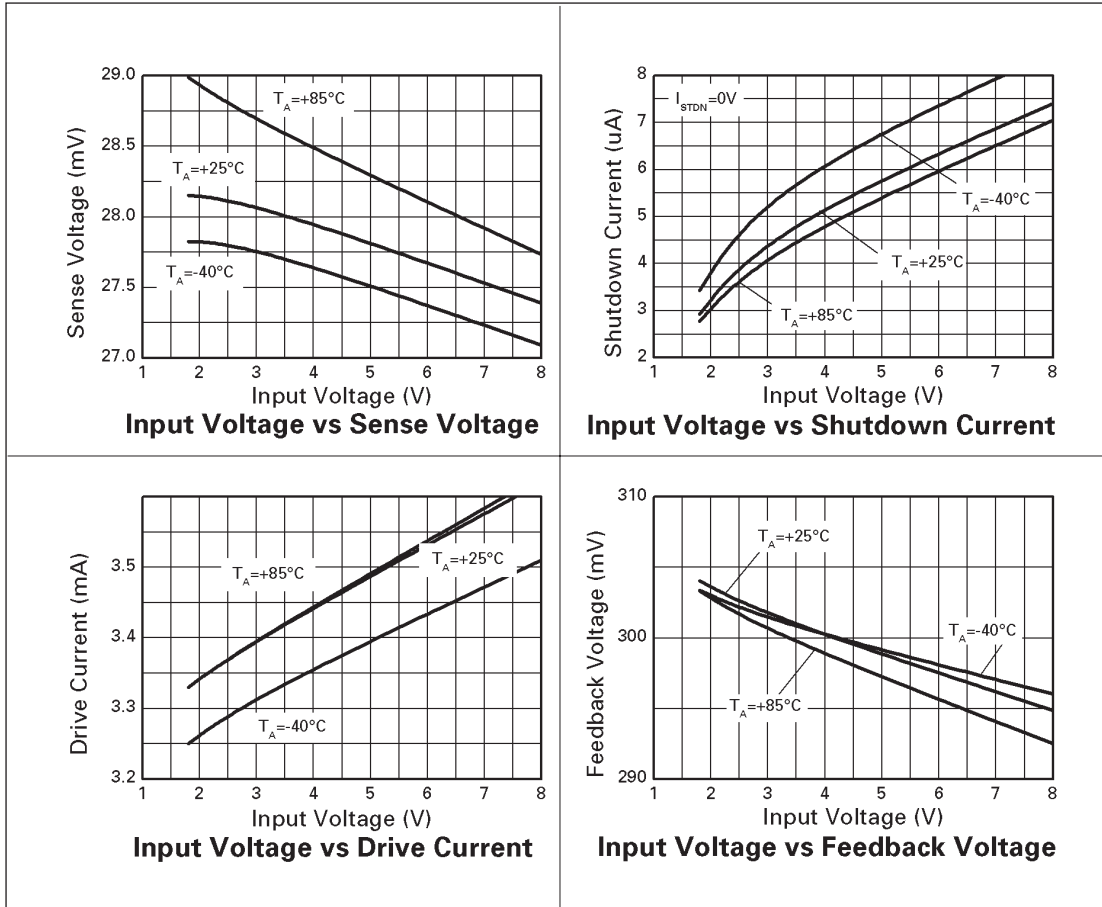

ZXSC410 ZXSC420

DEVICE DESCRIPTION

Bandgap Reference

All threshold voltages and internal currents are derived from a temperature compensated bandgap reference circuit with a reference voltage of 1.22V nominal.

Dynamic Drive Output

Depending on the input signal, the output is either "LOW" or "HIGH". In the high state a 2.5mA current source (max drive voltage = $V_{CC} - 0.4V$) drives the base or gate of the external transistor. In order to operate the external switching transistor at optimum efficiency, both output states are initiated with a short transient current in order to quickly discharge the base or the gate of the switching transistor.

Switching Circuit

The switching circuit consists of two comparators, Comp1 and Comp2, a gate U1, a monostable and the drive output. Normally the DRIVE output is "HIGH"; the external switching transistor is turned on. Current ramps up in the inductor, the switching transistor and external current sensing resistor. This voltage is sensed by comparator, Comp2, at input I_{SENSE} . Once the current sense voltage across the sensing resistor exceeds 20mV, comparator Comp2 through gate U1 triggers a re-triggerable monostable and turns off the output drive stage for 2 μ s. The inductor discharges to the load of the application. After 2 μ s a new charge cycle begins, thus ramping the output voltage. When the output voltage reaches the nominal value and V_{FB} gets an input voltage of more than 300mV, the monostable is forced "on" from Comp1 through gate U1, until the feedback voltage falls below 300mV. The above action continues to maintain regulation.

EOR, End of Regulation Detector

The EOR circuit is a retriggerable 120 μ s monostable, which is re-triggered by every down regulating action of comparator Comp1. As long as regulation takes place, output EOR is "HIGH" (high impedance, 100K to V_{CC}). Short dips of the output voltage of less than 120 μ s are ignored. If the output voltage falls below the nominal value for more than 120 μ s, output EOR goes "LOW". The reason for this to happen is usually a slowly progressing drop of input voltage from the discharging battery. Therefore the output voltage will also start to drop slowly. With the EOR detector, batteries can be used to the ultimate end of discharge, with enough time left for a safe shutdown.

Block Diagrams

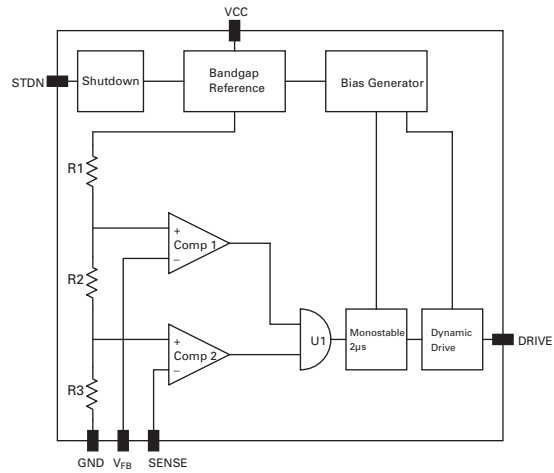

Fig. 1 ZXSC410

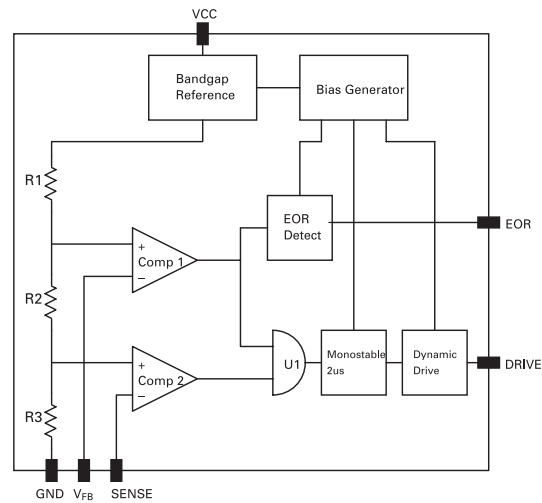

Fig. 1 ZXSC420

ZXSC410 ZXSC420

PIN DESCRIPTIONS

Pin No.	Name	Description
1	V _{CC}	Supply voltage, 1.8V to 8V.
2	GND	Ground
3	STDN/EOR	Shutdown ZXSC410 / End of regulation ZXSC420
4	SENSE	Inductor current sense input. Internal threshold voltage set to 28mV. Connect external sense resistor.
5	V _{FB}	Reference voltage. Internal threshold set to 300mV. Connect external resistor network to set output voltage.
6	DRIVE	Drive output for external switching transistor. Connect to base or gate of external switching transistor.

APPLICATIONS INFORMATION

Switching transistor selection

The choice of switching transistor has a major impact on the converter efficiency. For optimum performance, a bipolar transistor with low V_{CE(SAT)} and high gain is required. The V_{CEO} of the switching transistor is also an important parameter as this sees the full output voltage when the transistor is switched off. Zetex SuperSOT™ transistors are an ideal choice for this application.

Schottky diode selection

As with the switching transistor, the Schottky rectifier diode has a major impact on the converter efficiency. A Schottky diode with a low forward voltage and fast recovery time should be used for this application.

The diode should be selected so that the maximum forward current rating is greater or equal to the maximum peak current in the inductor, and the maximum reverse voltage is greater or equal to the output voltage. The Zetex ZHCS Series meet these needs.

Combination devices

To minimise the external component count Zetex recommends the ZX3CDBS1M832 combination of NPN transistor and Schottky diode in a 3mm x 2mm MLP package. This device is recommended for use in space critical applications.

The IC is also capable of driving MOSFETs. Zetex recommends the ZXMNS3BM832 combination of low threshold voltage N-Channel MOSFET and Schottky diode in a 3mm x 2mm MLP package. This device is recommended for use in space critical applications.

Inductor Selection

The inductor value must be chosen to satisfy performance, cost and size requirements of the overall solution.

Inductor selection has a significant impact on the converter performance. For applications where efficiency is critical, an inductor with a series resistance of 500mΩ or less should be used.

A list of recommended inductors is listed in the table below:

Part No.	Manufacture	L	I _{PK} (A)	R _{DC} (Ω)
CMD4D11-100MC	Sumida	10μH	0.5	0.457
CMD4D11-220MC	Sumida	22μH	0.4	0.676
LPO2506OB-103	Coilcraft	10μH	1.0	0.24
ST2006103	Standex Electronics Inc	10μH	0.6	0.1

Peak current definition

In general, the I_{PK} value must be chosen to ensure that the switching transistor, Q1, is in full saturation with maximum output power conditions, assuming worst-case input voltage and transistor gain under all operating temperature extremes.

Once I_{PK} is decided the value of R_{SENSE} can be determined by:

$$R_{SENSE} = \frac{V_{SENSE}}{I_{PK}}$$

ZXSC410

ZXSC420

Sense Resistor

A low value sense resistor is required to set the peak current. Power in this resistor is negligible due to the low sense voltage threshold, V_{SENSE} . Below is a table of recommended sense resistors:

Manufacture	Series	$R_{DC}(\Omega)$ Range	Size	Tolerance	URL
Cyntec	RL1220	0.022 - 10	0805	±5%	http://www.cyntec.com
IRC	LR1206	0.010 - 1.0	1206	±5%	http://www.icct.com

Output power calculation

By making the above assumptions for inductance and peak current the output power can be determined by:

$$P_{OUT} = I_{AV} \times V_{IN} \times \eta = (\text{Watts})$$

where

$$I_{AV} = \frac{I_{PK}}{2} \times \frac{(T_{ON} + T_{DIS})}{(T_{ON} + T_{OFF})}$$

and

$$T_{ON} = \frac{I_{PK} \times L}{V_{IN}}$$

and

$$T_{DIS} = \frac{I_{PK} \times L}{V_{OUT} - V_{IN}}$$

and

$$T_{OFF} \cong 1.7\mu\text{s} \text{ (internally set by ZXSC410)}$$

and

$$\eta = \text{efficiency i.e. } 100\% = 1$$

Operating frequency can be derived by:

$$F = \frac{1}{T_{ON} + T_{OFF}}$$

Output capacitors

Output capacitors are a critical choice in the overall performance of the solution. They are required to filter the output and supply load transient currents. There are three parameters which are paramount in the selection of the output capacitors, capacitance, IRIPPLE and ESR. The capacitance value is selected to meet the load transient requirements. The capacitors IRIPPLE rating must meet or exceed the current ripple of the solution.

The ESR of the output capacitor can also affect loop stability and transient performance. The capacitors selected for the solutions, and indicated in the reference designs, are optimised to provide the best overall performance.

Input capacitors

The input capacitor is chosen for its voltage and RMS current rating. The use of low ESR electrolytic or tantalum capacitors is recommended. Capacitor values for optimum performance are suggested in the reference design section

Also note that the ESR of the input capacitor is effectively in series with the input and hence contributes to efficiency losses in the order of $I_{RMS}^2 \cdot ESR$.

ZXSC410 ZXSC420

Output voltage adjustment

The ZXSC410/420 are adjustable output converters allowing the end user the maximum flexibility. For adjustable operation a potential divider network is connected as follows:

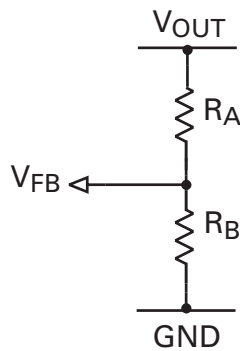

The output voltage is determined by the equation:

$$V_{OUT} = V_{FB} \left(1 + \frac{R_A}{R_B} \right)$$

where $V_{FB}=300\text{mV}$

The resistor values, R_A and R_B , should be maximised to improve efficiency and decrease battery drain. Optimisation can be achieved by providing a minimum current of $I_{FB(MAX)}=200\text{nA}$ to the V_{FB} pin. Output is adjustable from V_{FB} to the (BR)VCEO of the switching transistor, Q1.

Note: For the reference designs, R_A is assigned the label R2 and R_B the label R3.

Layout issues

Layout is critical for the circuit to function in the most efficient manner in terms of electrical efficiency, thermal considerations and noise.

For 'step-up converters' there are four main current loops, the input loop, power-switch loop, rectifier loop and output loop. The supply charging the input capacitor forms the input loop. The power-switch loop is defined when Q1 is 'on', current flows from the input through the inductor, Q1, R_{SENSE} and to ground. When Q1 is 'off', the energy stored in the inductor is transferred to the output capacitor and load via D1, forming the rectifier loop. The output loop is formed by the output capacitor supplying the load when Q1 is switched back off.

To optimise for best performance each of these loops kept separate from each other and interconnected with short, thick traces thus minimising parasitic inductance, capacitance and resistance. Also the R_{SENSE} resistor should be connected, with minimum trace length, between emitter lead of Q1 and ground, again minimising stray parasitics.

CONNECTION DIAGRAMS

ZXSC410
SOT23-6

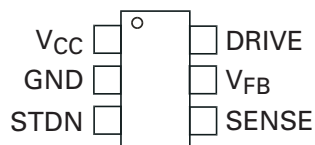

ZXSC420
SOT23-6

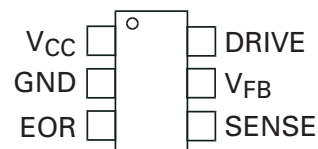

ZXSC410 ZXSC420

REFERENCE DESIGNS

ZXSC410 DC-DC Controller

$V_{IN}=2.5V$ to $4.2V$

$V_{OUT}=5V$; $I_{LOAD}=100mA$

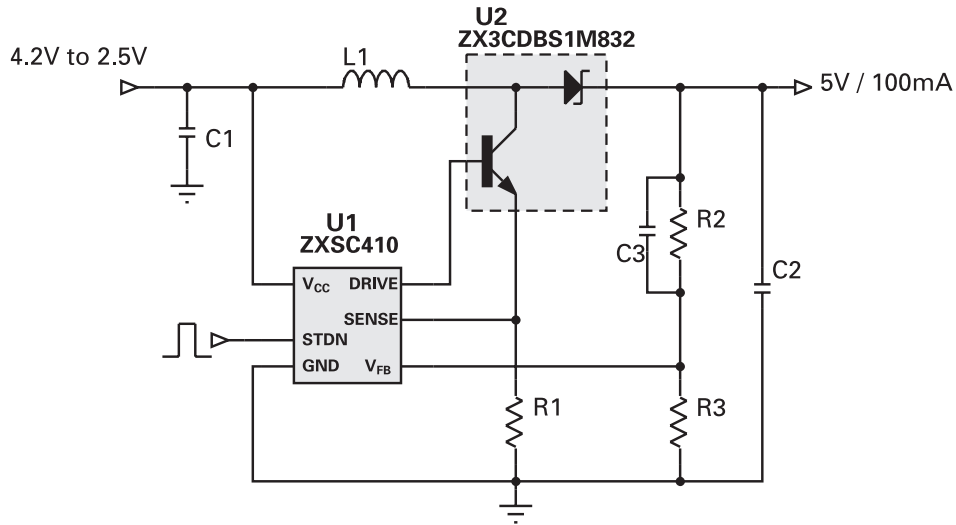

Bill of Materials

Ref	Value	Part Number	Manufacture	Comments
U1		ZXSC410E6	Zetex	DC-DC converter IC
U2		ZX3CDBS1M832	Zetex	Low sat NPN + 1A Schottky
L1	22 μ H	CMD4D11-220	Sumida	1mm height profile
R1	100m Ω	LR1206 / RL1220	IRC / Cynotec	1206 / 0805 size
R2	16k Ω	Generic	Generic	0603 size
R3	1k Ω	Generic	Generic	0603 size
C1	22 μ F/6V3	GRM Series	Murata	1206 size
C2	22 μ F/6V3	GRM Series	Murata	1206 size
C3	1nF	Generic	Generic	0603 size

ZXSC410 ZXSC420

Performance Graphs

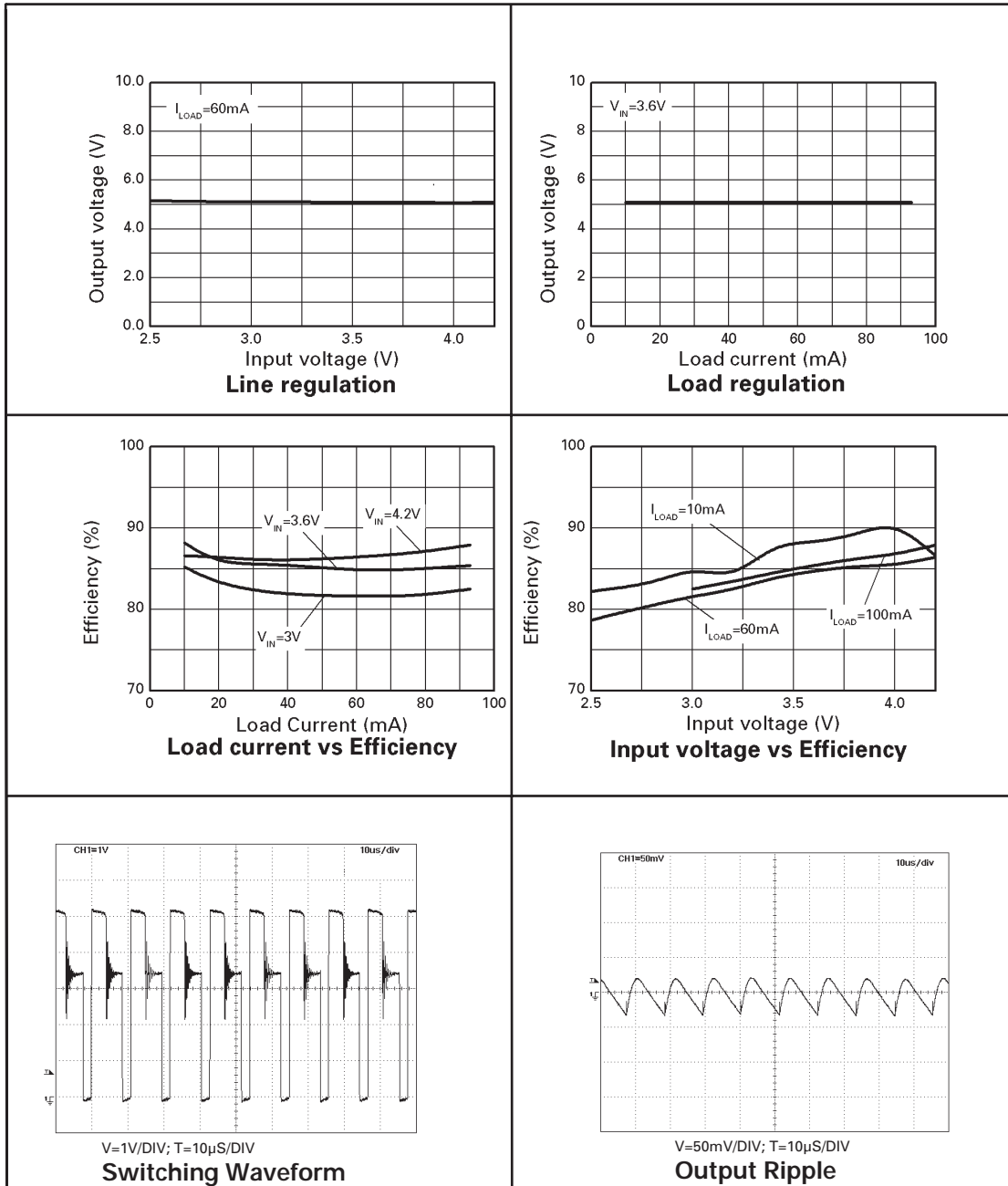

ZXSC410 ZXSC420

ZXSC410 as Triple Output TFT Bias

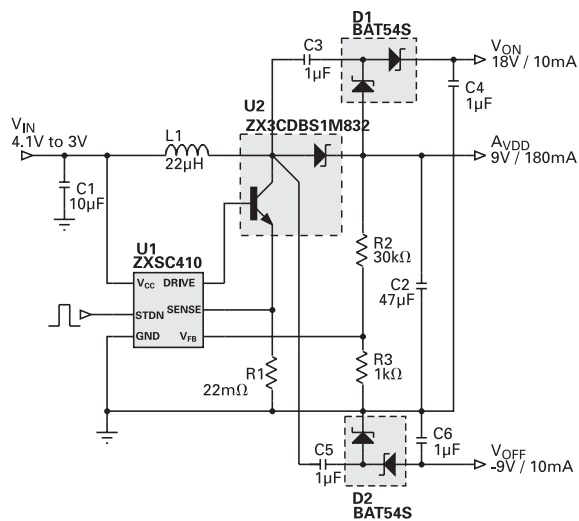

$V_{DD}=9V/180mA$
 $V_{ON}=18V/10mA$
 $V_{OFF}=9V/10mA$

ZXSC410 as Triple Output TFT Bias

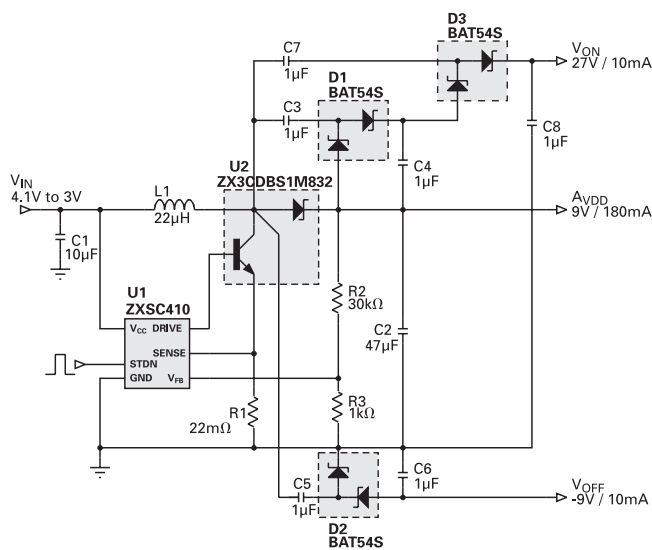

$V_{DD}=9V/180mA$
 $V_{ON}=27V/10mA$
 $V_{OFF}=9V/10mA$

ZXSC410 ZXSC420

Sequencing A_{VDD} and V_{ON}

By adding the circuit below to the LCD bias output (V_{ON}) of the converter a 10ms delay can be achieved between A_{VDD} power up and V_{ON} power up. The circuit operates by a delay in turning the PMOS transistor on, which transfers to a 10ms delay between input and output of the circuit.

The delay is set by the RC time constant of R1 and C1. The diode, D1, discharges the gate of the PMOS when the main system supply is turned off, guaranteeing a delay every turn on cycle.

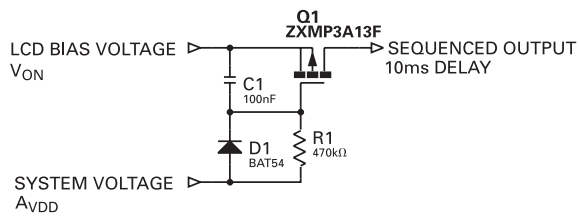

ZXSC410 ZXSC420

PACKAGE OUTLINE

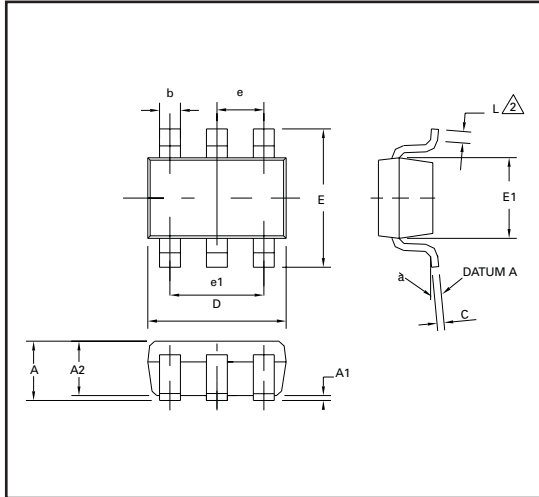

PAD LAYOUT DETAILS

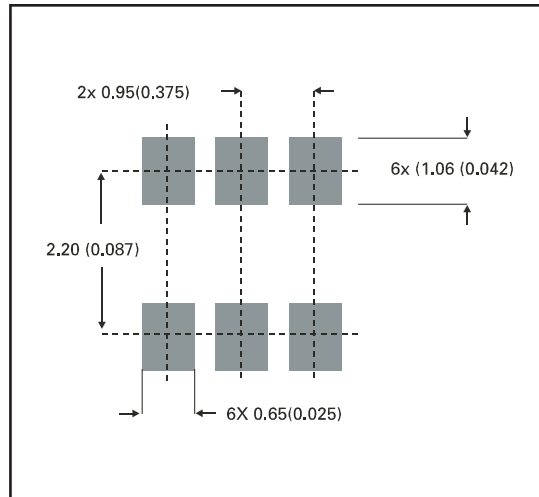

CONTROLLING DIMENSIONS IN MILLIMETRES APPROX CONVERSIONS INCHES.

PACKAGE DIMENSIONS

DIM	Millimetres		Inches		DIM	Millimetres		Inches	
	Min	Max	Min	Max		Min	Max	Min	Max
A	0.90	1.45	0.35	0.057	E	2.60	3.00	0.102	0.118
A1	0.00	0.15	0	0.006	E1	1.50	1.75	0.059	0.069
A2	0.90	1.30	0.035	0.051	L	0.10	0.60	0.004	0.002
b	0.35	0.50	0.014	0.019	e	0.95 REF		0.037 REF	
C	0.09	0.20	0.0035	0.008	e1	1.90 REF		0.074 REF	
D	2.80	3.00	0.110	0.118	L	0°	10°	0°	10°

© Zetex plc 2003

Europe

Zetex plc
Fields New Road
Chadderton
Oldham, OL9 8NP
United Kingdom
Telephone: (44) 161 622 4444
Fax: (44) 161 622 4446
hq@zetex.com

Zetex GmbH
Streitfeldstraße 19
D-81673 München
Germany
Telephone: (49) 89 45 49 49 0
Fax: (49) 89 45 49 49 49
europe.sales@zetex.com

Americas

Zetex Inc
700 Veterans Memorial Hwy
Hauppauge, NY 11788
USA
Telephone: (1) 631 360 2222
Fax: (1) 631 360 8222
usa.sales@zetex.com

Asia Pacific

Zetex (Asia) Ltd
3701-04 Metroplaza Tower 1
Hing Fong Road
Kwai Fong
Hong Kong
Telephone: (852) 26100 611
Fax: (852) 24250 494
asia.sales@zetex.com

These offices are supported by agents and distributors in major countries world-wide.

This publication is issued to provide outline information only which (unless agreed by the Company in writing) may not be used, applied or reproduced for any purpose or form part of any order or contract or be regarded as a representation relating to the products or services concerned. The Company reserves the right to alter without notice the specification, design, price or conditions of supply of any product or service.

For the latest product information, log on to www.zetex.com



ISSUE 2 - May 2003

Looking for pricing, stock, or lifecycle information?

Click below to explore more details on WIN SOURCE:

 [View ZXSC420E6TA on WIN SOURCE](#)

 [Diodes Incorporated Information](#)

Optimize Your Supply Chain with WIN SOURCE Solutions

-  Global Sourcing Solution
-  Obsolete Management
-  Cost Control Management
-  Shortage Management
-  Alternative Solution
-  Excess Inventory Management