

ZXTP03200BZ

200V PNP LOW $V_{CE(sat)}$ TRANSISTOR IN SOT-89

Features

- $BV_{CEO} > -200V$
- $BV_{ECO} > -2V$
- Continuous current $I_{C(cont)} = 2A$
- $V_{CE(sat)} < -160mV @ -1A$
- $R_{CE(sat)} = 130m\Omega$
- $P_D = 2.4W$
- 2 Amps continuous current
- Up to 5 Amps peak current
- Very low saturation voltage
- Enhanced switching performance

Mechanical Data

- Case: SOT-89
- UL Flammability Rating 94V-0
- Moisture Sensitivity: Level 1 per J-STD-020
- Terminals: Matte Tin Finish
- Weight: 0.052 grams (approximate)

Applications

- DC-DC Convertors

SOT-89



Top View

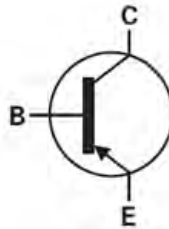

Device symbol

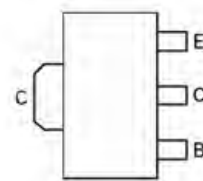

Pin Configuration

Ordering Information

Product	Marking	Reel size (inches)	Tape width (mm)	Quantity per reel
ZXTP03200BZTA	1N2	7	12	1000

Marking Information

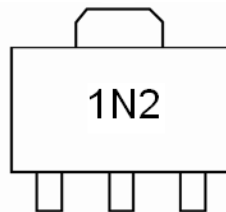

1N2 = Product type Marking Code

ZXTP03200BZ

200V PNP LOW $V_{CE(sat)}$ TRANSISTOR IN SOT-89

Maximum Ratings @ $T_A = 25^\circ\text{C}$ unless otherwise specified

Characteristic	Symbol	Value	Unit
Collector-Base Voltage	V_{CBO}	-220	V
Collector-Emitter Voltage	V_{CEO}	-200	V
Emitter-Base Voltage	V_{EBO}	-7	V
Continuous Collector Current (Note a)	I_C	-2	A
Base Current	I_B	-1	A
Peak Pulse Current	I_{CM}	-5	A

Thermal Characteristics

Characteristic	Symbol	Value	Unit
Power Dissipation at $T_A = 25^\circ\text{C}$ (Note a) Linear derating factor	P_D	1.1 8.8	W mW/°C
Power Dissipation at $T_A = 25^\circ\text{C}$ (Note b) Linear derating factor	P_D	1.8 14.4	W mW/°C
Power Dissipation at $T_A = 25^\circ\text{C}$ (Note c) Linear derating factor	P_D	2.4 19.2	W mW/°C
Power Dissipation at $T_A = 25^\circ\text{C}$ (Note d) Linear derating factor	P_D	4.46 35.7	W mW/°C
Power Dissipation at $T_A = 25^\circ\text{C}$ (Note e) Linear derating factor	P_D	38.7 309.6	W mW/°C
Junction to Ambient (Note a)	$R_{\theta JA}$	117	°C/W
Junction to Ambient (Note b)	$R_{\theta JA}$	68	°C/W
Junction to Ambient (Note c)	$R_{\theta JA}$	51	°C/W
Junction to Ambient (Note d)	$R_{\theta JA}$	28	°C/W
Junction to Lead (Note e)	$R_{\theta JL}$	3.23	°C/W
Operating and Storage Temperature Range	T_J, T_{STG}	-55 to +150	°C

- Notes:
- a. For a device surface mounted on 15mm X 15mm X 1.6mm FR4 PCB with high coverage of single sided 1 oz copper, in still air conditions
 - b. Mounted on 25mm X 25mm X 1.6mm FR4 PCB with high coverage of single sided 1 oz copper, in still air conditions.
 - c. Mounted on 25mm X 25mm X 1.6mm FR4 PCB with high coverage of single sided 2 oz copper, in still air conditions.
 - d. As (c) above measured at $t < 5$ seconds
 - e. Junction to lead from collector Tab. Typical

ZXTP03200BZ

200V PNP LOW $V_{CE(sat)}$ TRANSISTOR IN SOT-89

Thermal Characteristics and Derating information

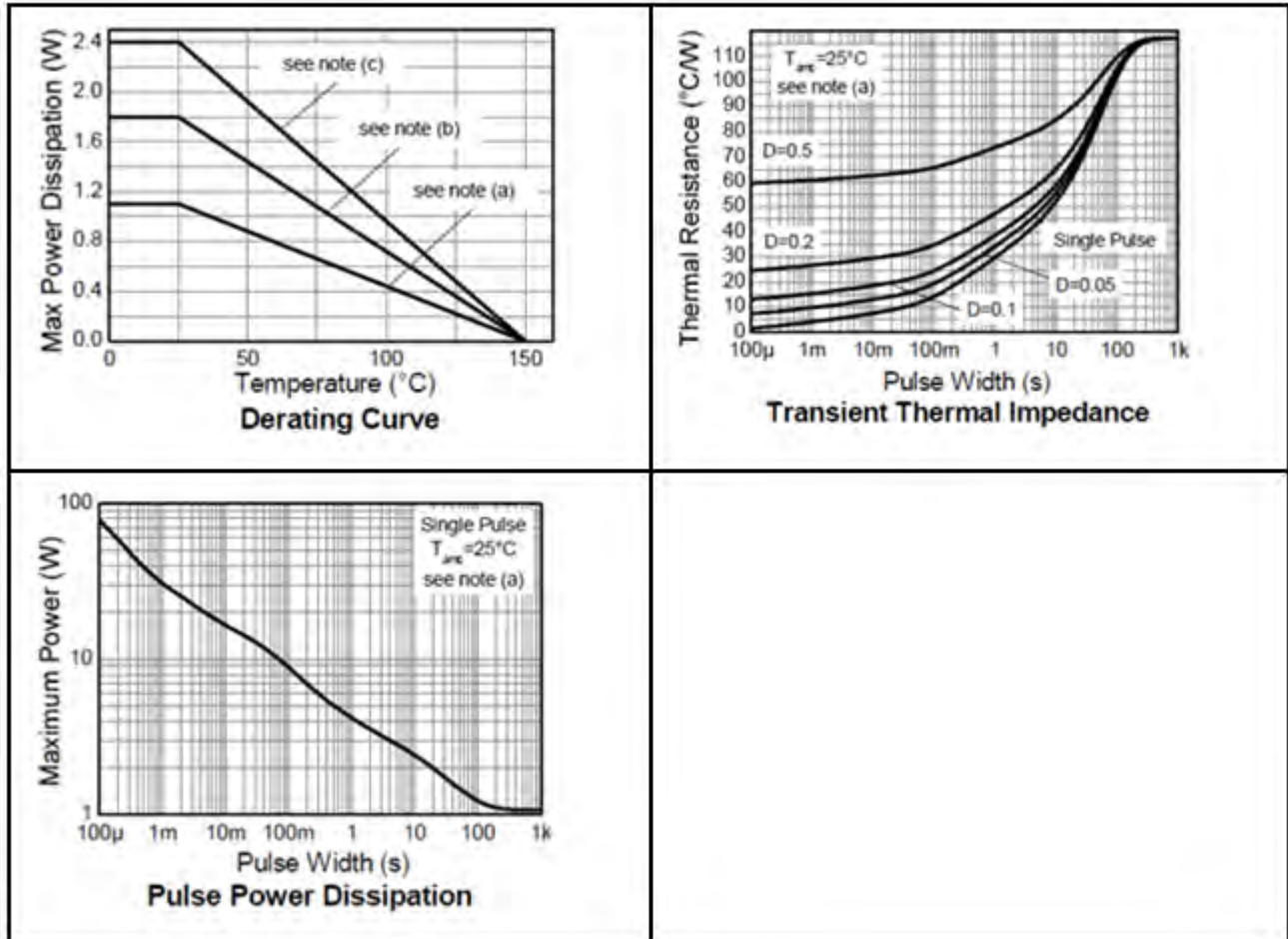

ZXTP03200BZ

200V PNP LOW $V_{CE(sat)}$ TRANSISTOR IN SOT-89

Electrical Characteristics @ $T_A = 25^\circ\text{C}$ unless otherwise specified

Characteristic	Symbol	Min	Typ	Max	Unit	Test Condition
Collector-Base Breakdown Voltage	$V_{(BR)CBO}$	-220	-245		V	$I_C = -100\mu\text{A}$
Collector-Emitter Breakdown Voltage	$V_{(BR)CER}$	-220	-245		V	$I_C = -1\mu\text{A}$, $R_{BE} \leq 1\text{k}\Omega$
Collector-Emitter Breakdown Voltage (Note f)	$V_{(BR)CEO}$	-220	-225		V	$I_C = -10\text{mA}$
Emitter-Base Breakdown Voltage	$V_{(BR)EBO}$	-7	-8.4		V	$I_E = -100\mu\text{A}$
Collector-Base Cutoff Current	I_{CBO}		<1	-50 -0.5	nA μA	$V_{CB} = -200\text{V}$ $V_{CB} = -200\text{V}$, $T_{amb} = 100^\circ\text{C}$
Emitter Cutoff Current	I_{EBO}		<1	-10	nA	$V_{EB} = -6\text{V}$
Static Forward Current Transfer Ratio (Note f)	h_{FE}	100 100 20	195 179 50 5	300		$I_C = -10\text{mA}$, $V_{CE} = -5\text{V}$ $I_C = -1\text{A}$, $V_{CE} = -5\text{V}$ $I_C = -2\text{A}$, $V_{CE} = -5\text{V}$ $I_C = -5\text{A}$, $V_{CE} = -5\text{V}$
Collector-Emitter Saturation Voltage (Note f)	$V_{CE(sat)}$		-37 -120 -130 -160	-50 -155 -160 -260	mV mV mV mV	$I_C = -100\text{mA}$, $I_B = -10\text{mA}$ $I_C = -500\text{mA}$, $I_B = -25\text{mA}$ $I_C = -1\text{A}$, $I_B = -100\text{mA}$ $I_C = -2\text{A}$, $I_B = -400\text{mA}$
Base-Emitter Saturation Voltage (Note f)	$V_{BE(sat)}$		-940	-1100	mV	$I_C = -2\text{A}$, $I_B = -400\text{mA}$
Base-Emitter Turn-On Voltage (Note f)	$V_{BE(ON)}$		-840	-1000	mV	$I_C = -2\text{A}$, $V_{CE} = -5\text{V}$
Output Capacitance (Note f)	C_{obo}		31		pF	$V_{CB} = -10\text{V}$, $f = 1\text{MHz}$
Transition Frequency	f_T		105		MHz	$V_{CE} = -10\text{V}$, $I_C = -100\text{mA}$ $f = 50\text{MHz}$
Delay Time	t_d		21		ns	$V_{CC} = -50\text{V}$, $I_C = -1\text{A}$ $I_{B1} = -I_{B2} = -100\text{mA}$
Rise Time	t_r		18		ns	
Storage Time	T_s		680		ns	
Fall Time	T_f		75		ns	

Notes: f. Measured under pulsed conditions. Pulse width = 300 μs . Duty cycle $\leq 2\%$

ZXTP03200BZ

200V PNP LOW $V_{CE(sat)}$ TRANSISTOR IN SOT-89

Typical Characteristics

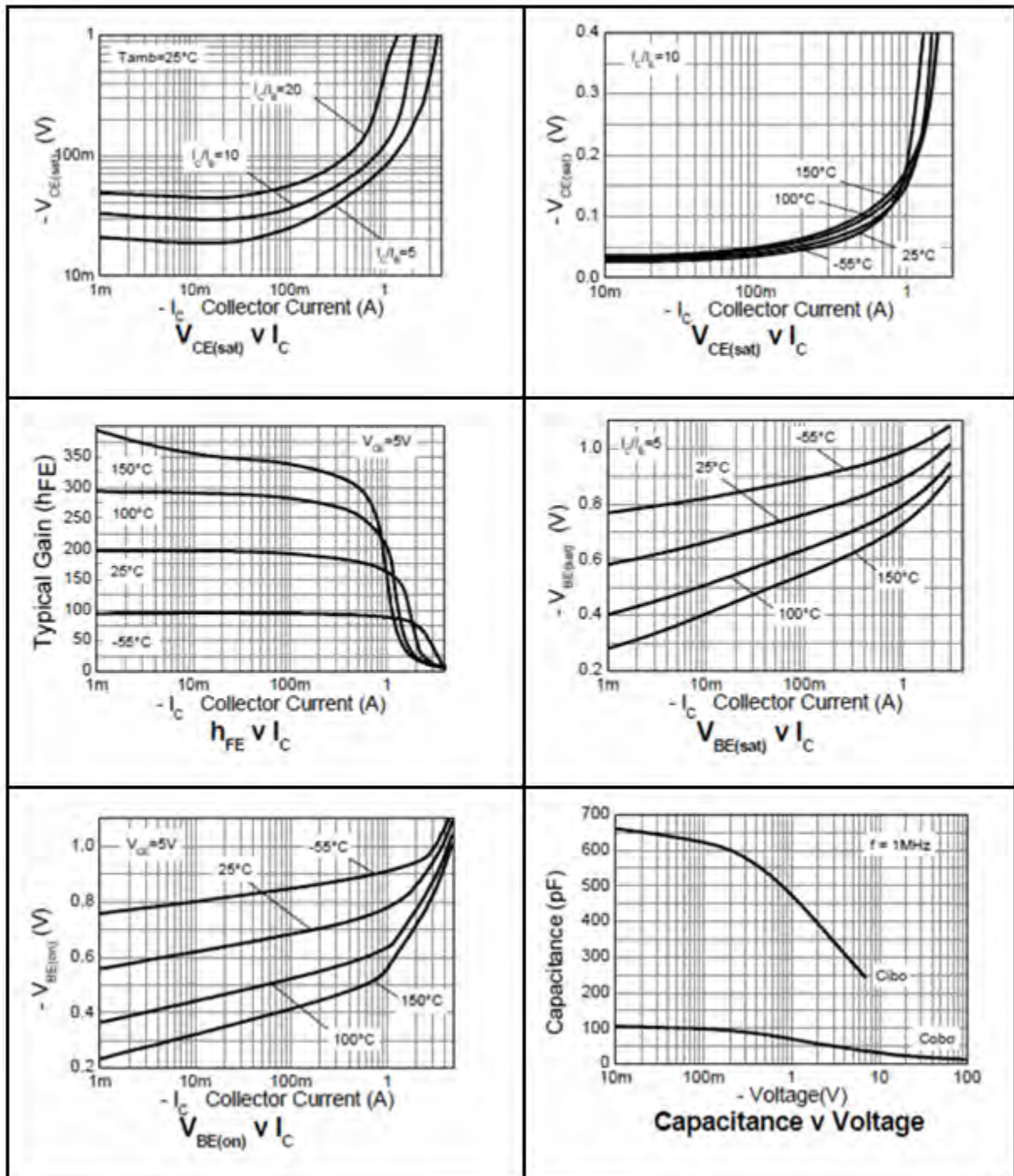

ZXTP03200BZ

200V PNP LOW $V_{CE(sat)}$ TRANSISTOR IN SOT-89

Package Outline Dimensions

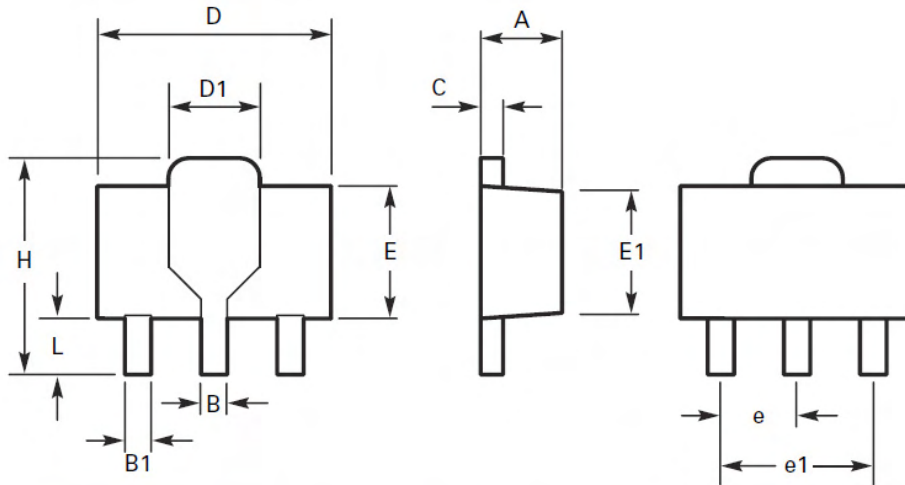

DIM	Millimeters		Inches		DIM	Millimeters		Inches	
	Min	Max	Min	Max		Min	Max	Min	Max
A	1.40	1.60	0.550	0.630	E	2.29	2.60	0.090	0.102
B	0.44	0.56	0.017	0.022	E1	2.13	2.29	0.084	0.090
B1	0.36	0.48	0.014	0.019	e	1.50 BSC		0.059 BSC	
C	0.35	0.44	0.014	0.017	e1	3.00 BSC		0.118 BSC	
D	4.40	4.60	0.173	0.181	H	3.94	4.25	0.155	0.167
D1	1.52	1.83	0.064	0.072	L	0.89	1.20	0.035	0.047

Note: Controlling dimensions are in millimeters. Approximate dimensions are provided in inches

Suggested Pad Layout

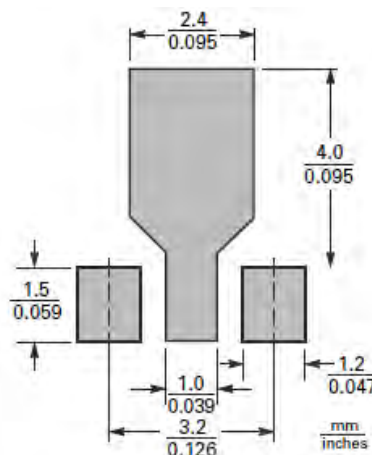

ZXTP03200BZ**200V PNP LOW $V_{CE(sat)}$ TRANSISTOR IN SOT-89****IMPORTANT NOTICE**

DIODES INCORPORATED MAKES NO WARRANTY OF ANY KIND, EXPRESS OR IMPLIED, WITH REGARDS TO THIS DOCUMENT, INCLUDING, BUT NOT LIMITED TO, THE IMPLIED WARRANTIES OF MERCHANTABILITY AND FITNESS FOR A PARTICULAR PURPOSE (AND THEIR EQUIVALENTS UNDER THE LAWS OF ANY JURISDICTION).

Diodes Incorporated and its subsidiaries reserve the right to make modifications, enhancements, improvements, corrections or other changes without further notice to this document and any product described herein. Diodes Incorporated does not assume any liability arising out of the application or use of this document or any product described herein; neither does Diodes Incorporated convey any license under its patent or trademark rights, nor the rights of others. Any Customer or user of this document or products described herein in such applications shall assume all risks of such use and will agree to hold Diodes Incorporated and all the companies whose products are represented on Diodes Incorporated website, harmless against all damages.

Diodes Incorporated does not warrant or accept any liability whatsoever in respect of any products purchased through unauthorized sales channel. Should Customers purchase or use Diodes Incorporated products for any unintended or unauthorized application, Customers shall indemnify and hold Diodes Incorporated and its representatives harmless against all claims, damages, expenses, and attorney fees arising out of, directly or indirectly, any claim of personal injury or death associated with such unintended or unauthorized application.

Products described herein may be covered by one or more United States, international or foreign patents pending. Product names and markings noted herein may also be covered by one or more United States, international or foreign trademarks.

LIFE SUPPORT

Diodes Incorporated products are specifically not authorized for use as critical components in life support devices or systems without the express written approval of the Chief Executive Officer of Diodes Incorporated. As used herein:

- A. Life support devices or systems are devices or systems which:
1. are intended to implant into the body, or
 2. support or sustain life and whose failure to perform when properly used in accordance with instructions for use provided in the labeling can be reasonably expected to result in significant injury to the user.
- B. A critical component is any component in a life support device or system whose failure to perform can be reasonably expected to cause the failure of the life support device or to affect its safety or effectiveness.

Customers represent that they have all necessary expertise in the safety and regulatory ramifications of their life support devices or systems, and acknowledge and agree that they are solely responsible for all legal, regulatory and safety-related requirements concerning their products and any use of Diodes Incorporated products in such safety-critical, life support devices or systems, notwithstanding any devices- or systems-related information or support that may be provided by Diodes Incorporated. Further, Customers must fully indemnify Diodes Incorporated and its representatives against any damages arising out of the use of Diodes Incorporated products in such safety-critical, life support devices or systems.

Copyright © 2009, Diodes Incorporated

www.diodes.com

Looking for pricing, stock, or lifecycle information?

Click below to explore more details on WIN SOURCE:

 [View ZXTP03200BZTA on WIN SOURCE](#)

 [Diodes Incorporated](#) Information

Optimize Your Supply Chain with WIN SOURCE Solutions

-  Global Sourcing Solution
-  Obsolete Management
-  Cost Control Management
-  Shortage Management
-  Alternative Solution
-  Excess Inventory Management