

RoHS  **SL1011A/B and SL1411A Series**

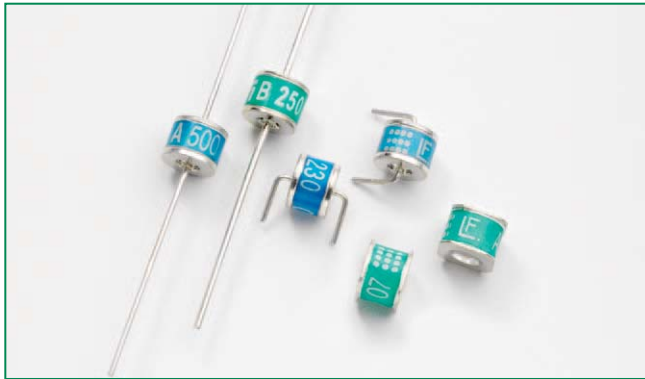

Description

The SL1011A/B and SL1411A series provides high levels of protection against fast rising transients in the 100V/μs to 1kV/μs range usually caused by lightning disturbances.

The SL1011A/B and SL1411A series offers low capacitance (< 1.5pf) which provides low insertion loss at high frequencies.

SL1011A offers 5kA protection without destruction whereas the SL1011B and SL1411A offer 10kA surge protection without destruction (maximum single surge of 12kA @ 8/20μs).

Agency Approvals

AGENCY	AGENCY FILE NUMBER
	E128662

2 Electrode GDT Graphical Symbol



Features

- RoHS compliant
- Low insertion loss
- Excellent response to fast rising transients
- Ultra low capacitance
- 5kA (SL1011A) or 10kA (SL1011B & SL1411A) surge capability tested with 8/20μs pulse as defined by IEC 61000-4-5

Applications

- Broadband equipment
- ADSL equipment
- XDSL equipment
- Satellite and CATV equipment
- General telecom equipment

Electrical Characteristics

Part Number	Device Specifications (at 25°C)								Life Ratings																																				
	DC Breakdown in Volts ^{1,2} (@100V/s)			Impulse Breakdown in Volts ³ (@100V/μs)	Impulse Breakdown In Volts (@1kV/μs)	Insulation Resistance	Capacitance (@1MHz)	Arc Voltage (on state Voltage) @1Amp Min	Surge Life (@100A 10/1000μs)	Nominal Impulse Discharge Current (@20μs)	Nominal AC Discharge Current (10x1s @50-60Hz)	AC Discharge Current (9 Cycles @ 50Hz)	DC Holdover Voltage ⁴	Max Impulse Discharge Current (1 Application)																															
	MIN	TYP	MAX	MAX		MIN	MAX	TYP					TYP	@ 8/20μs	@ 10/350μs																														
SL1011A075	60	75	90	500	700	10 ¹⁰ Ω (at 50V)	1.5 pF	~20 V	300 shots	SL1011A: 10 shots (@5kA)	SL1011A: 5 A	SL1011A: 20 A	50 V	SL1011B & SL1411A: 12 kA	1 kA																														
SL1011B075																																													
SL1411A075	72	90	108	500	600											10 ¹⁰ Ω (at 100V)	1.5 pF	~20 V	300 shots	SL1011B & SL1411A: 10 shots (@10kA)	SL1011B & SL1411A: 10 A	SL1011B & SL1411A: 65 A	135 V	SL1011B & SL1411A: 12 kA	1 kA																				
SL1011A090																																													
SL1011B090																																													
SL1411A090																																													
SL1011A145	116	145	174	500	650																					10 ¹⁰ Ω (at 100V)	1.5 pF	~20 V	300 shots	SL1011B & SL1411A: 10 shots (@10kA)	SL1011B & SL1411A: 10 A	SL1011B & SL1411A: 65 A	135 V	SL1011B & SL1411A: 12 kA	1 kA										
SL1011B145																																													
SL1011A150	120	150	180	500	650																															10 ¹⁰ Ω (at 100V)	1.5 pF	~20 V	300 shots	SL1011B & SL1411A: 10 shots (@10kA)	SL1011B & SL1411A: 10 A	SL1011B & SL1411A: 65 A	135 V	SL1011B & SL1411A: 12 kA	1 kA
SL1011B150																																													
SL1011A230	184	230	276	550	700	10 ¹⁰ Ω (at 100V)	1.5 pF	~20 V	300 shots	SL1011B & SL1411A: 10 shots (@10kA)	SL1011B & SL1411A: 10 A	SL1011B & SL1411A: 65 A	135 V	SL1011B & SL1411A: 12 kA	1 kA																														
SL1011B230																																													
SL1411A230	200	250	300	600	800											10 ¹⁰ Ω (at 100V)	1.5 pF	~20 V	300 shots	SL1011B & SL1411A: 10 shots (@10kA)	SL1011B & SL1411A: 10 A	SL1011B & SL1411A: 65 A	135 V	SL1011B & SL1411A: 12 kA	1 kA																				
SL1011A250																																													
SL1011B250																																													
SL1411A250																																													
SL1011A260	210	260	310	600	800																					10 ¹⁰ Ω (at 100V)	1.5 pF	~20 V	300 shots	SL1011B & SL1411A: 10 shots (@10kA)	SL1011B & SL1411A: 10 A	SL1011B & SL1411A: 65 A	135 V	SL1011B & SL1411A: 12 kA	1 kA										
SL1011B260																																													
SL1011A350	280	350	420	800	900																															10 ¹⁰ Ω (at 100V)	1.5 pF	~20 V	300 shots	SL1011B & SL1411A: 10 shots (@10kA)	SL1011B & SL1411A: 10 A	SL1011B & SL1411A: 65 A	135 V	SL1011B & SL1411A: 12 kA	1 kA
SL1011B350																																													
SL1411A350	376	470	564	1000	1100	10 ¹⁰ Ω (at 100V)	1.5 pF	~20 V	300 shots	SL1011B & SL1411A: 10 shots (@10kA)	SL1011B & SL1411A: 10 A	SL1011B & SL1411A: 65 A	135 V	SL1011B & SL1411A: 12 kA	1 kA																														
SL1011A470																																													
SL1411A470																																													
SL1011A500	400	500	600	1100	1200											10 ¹⁰ Ω (at 100V)	1.5 pF	~20 V	300 shots	SL1011B & SL1411A: 10 shots (@10kA)	SL1011B & SL1411A: 10 A	SL1011B & SL1411A: 65 A	135 V	SL1011B & SL1411A: 12 kA	1 kA																				
SL1011A600																																													
SL1411A600	480	600	720	1200	1400																																								
SL1011A600																																													

- Notes:
- At delivery AQL 0.65 level II, DIN ISO 2859
 - In ionized mode
 - Comparable to the silicon measurement Switching Voltage (Vs)
 - Tested according to ITU-T Rec. K.12 < 150 msec.

Product Characteristics

Materials	Leaded Device: Nickel-plated with Tin-plated wires Core and Surface Mount: Dull Tin-plated
Product Marking	Littelfuse 'LF' Mark, voltage and date code

Glow to Arc Transition Current	< 0.5 Amps
Glow Voltage	~60 Volts
Storage and Operational Temperature	-40 to +90°C

Device Dimensions

For SL1011A/SL1011B series:

'A' Type Axial Lead Devices

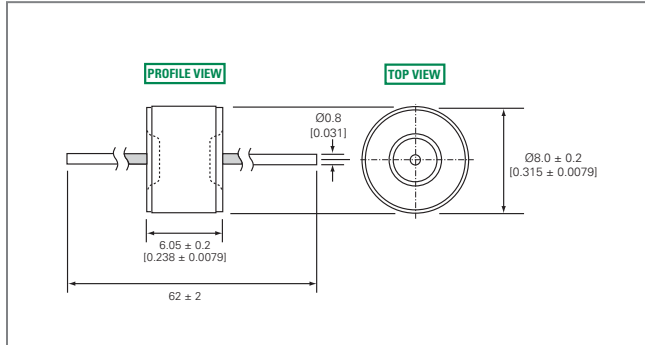

'C' Type Core Devices

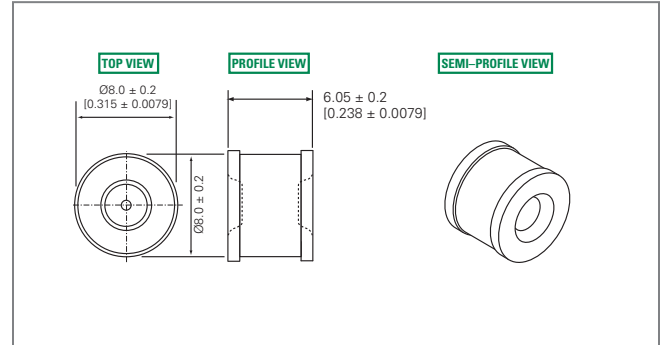

For SL1411A series:

'A' Type Axial Lead Devices

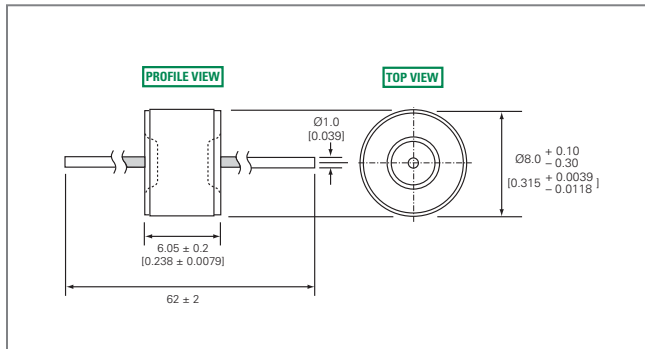

'SM' Type Surface Mount Devices

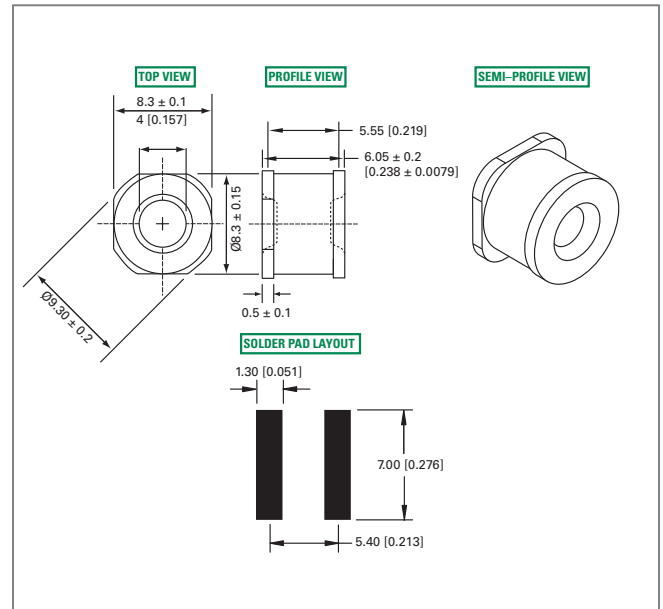

'C' Type Core Devices

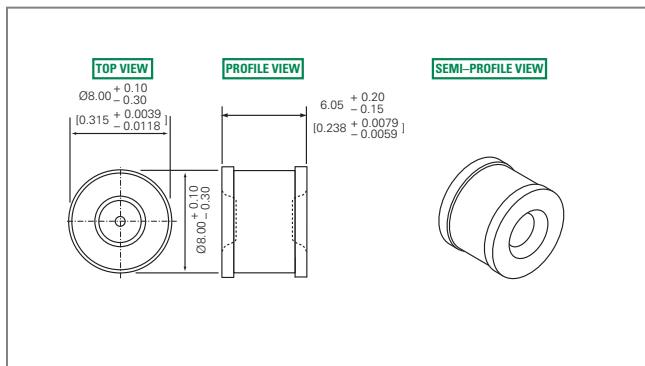

Soldering Parameters - Reflow Soldering (Surface Mount Devices)

Reflow Condition		Pb-free assembly
Pre Heat	- Temperature Min ($T_{s(min)}$)	150°C
	- Temperature Max ($T_{s(max)}$)	200°C
	- Time (Min to Max) (t_s)	60 – 180 seconds
Average Ramp-up Rate (Liquidus Temp (T_L) to peak)		3°C/second max.
$T_{s(max)}$ to T_L - Ramp-up Rate		5°C/second max.
Reflow	- Temperature (T_L) (Liquidus)	217°C
	- Temperature (t_L)	60 – 150 seconds
Peak Temperature (T_p)		260 ^{+0/-5} °C
Time within 5°C of Actual Peak Temperature (t_p)		10 – 30 seconds
Ramp-down Rate		6°C/second max.
Time 25°C to Peak Temperature (T_p)		8 minutes max.
Do not exceed		260°C

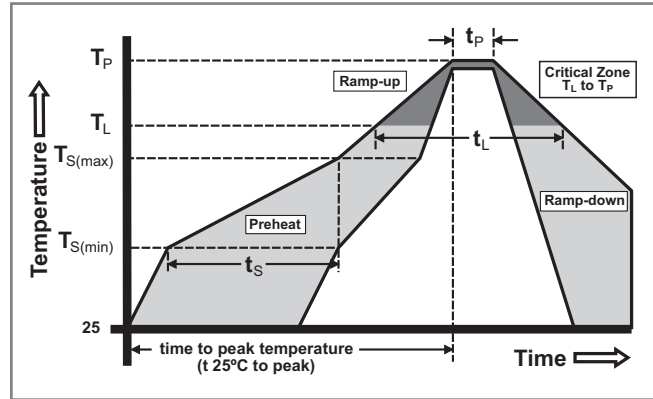

Soldering Parameters - Wave Soldering (Thru-Hole Devices)

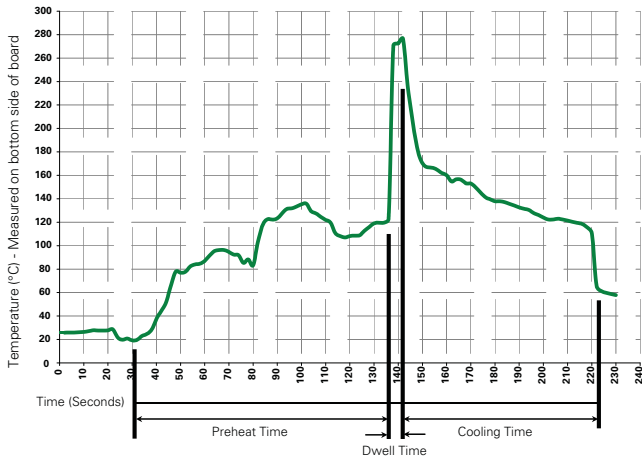

Recommended Process Parameters:

Wave Parameter	Lead-Free Recommendation
Preheat:	
(Depends on Flux Activation Temperature)	(Typical Industry Recommendation)
Temperature Minimum:	100° C
Temperature Maximum:	150° C
Preheat Time:	60-180 seconds
Solder Pot Temperature:	280° C Maximum
Solder Dwell Time:	2-5 seconds

Soldering Parameters - Hand Soldering

Solder Iron Temperature: 350° C +/- 5°C
 Heating Time: 5 seconds max.

Packaging Dimensions

For 'A' Type Axial Lead Items

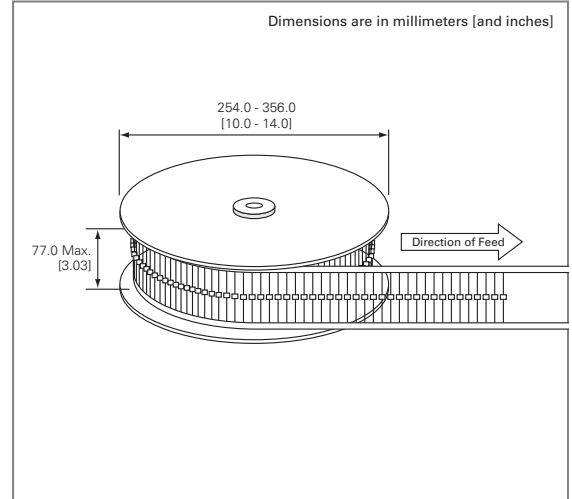
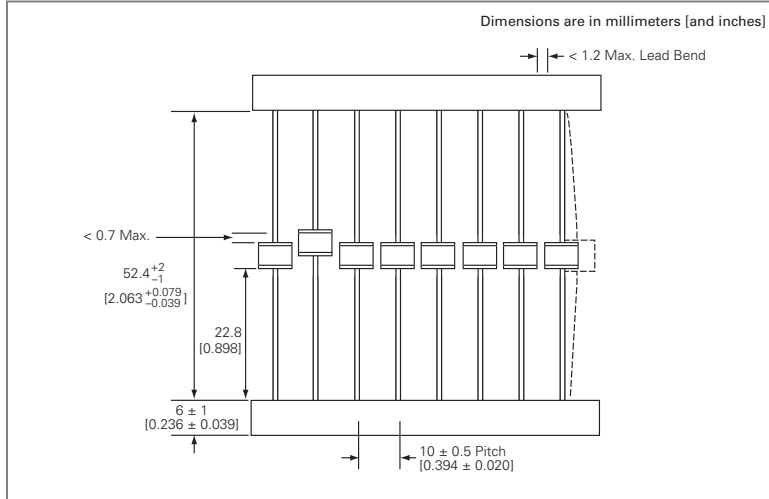

For 'SM' Type Surface Mount Items (SL1411A series only)

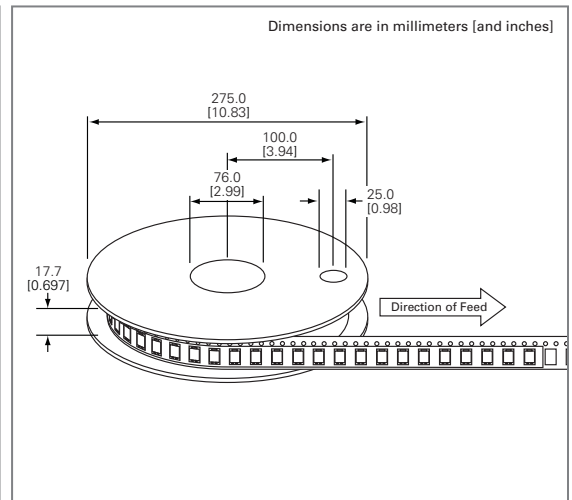
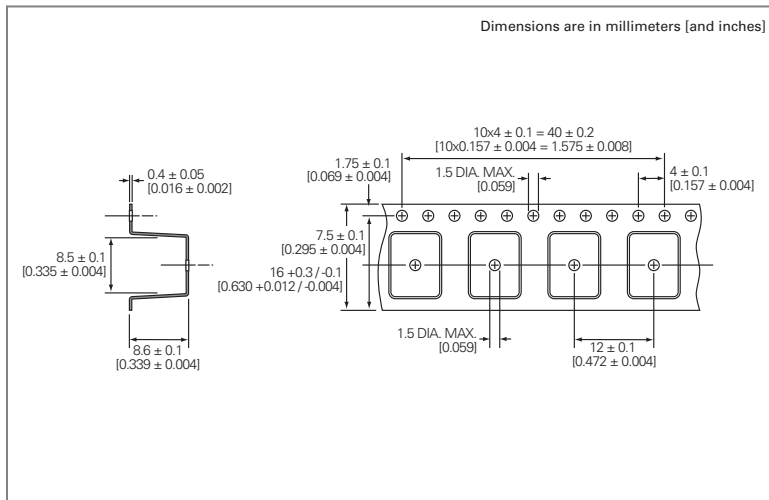

For 'C' Type Core Items: Packed in plastic bag (500 pcs)

Part Numbering System and Ordering Information

For SL1011A series:

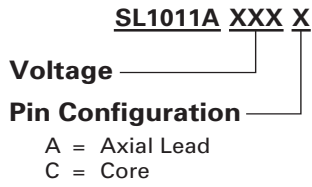

Remarks: Formed leads are available on request

For SL1011B series:

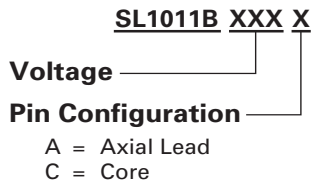

Remarks: Formed leads are available on request

For SL1411A series:

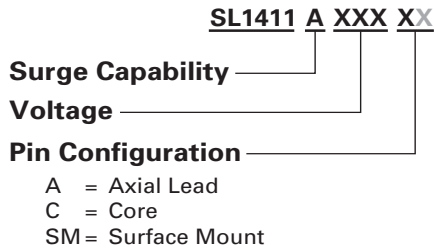

Looking for pricing, stock, or lifecycle information?

Click below to explore more details on WIN SOURCE:

 [View SL1011B260A on WIN SOURCE](#)

 [Littelfuse Inc. Information](#)

Optimize Your Supply Chain with WIN SOURCE Solutions

-  Global Sourcing Solution
-  Obsolete Management
-  Cost Control Management
-  Shortage Management
-  Alternative Solution
-  Excess Inventory Management