



**THE DATASHEET OF  
CG0201MLA-5.5MH**





## Features

- Miniature 0201 package
- Fast response time to ESD strikes (<1 ns)
- Bidirectional protection
- Low clamping voltage
- Low leakage current
- RoHS compliant\*

## Applications

- Smart phones
- Tablets
- Handheld devices
- Embedded components
- Scanners
- Notebooks

# ChipGuard® MLA Series μVaristor ESD Clamp Protector

## Description

Bourns® ChipGuard® MLA Series μVaristor ESD Clamp Protectors are based on multilayer metal oxide varistor technology. Bidirectional ESD protection is provided in a miniature 0201 package, making it one of the smallest protectors available on the market today. The series is ideally suited for space-constrained applications where circuit board space is at a premium.

## Electrical Characteristics @ 25 °C (unless otherwise noted)

Model	Vrms (V)	VDC (V)	VN Min. (V)	VN Max. (V)	VC (V)	ITM (Max.) (A)	WTM (Max.) (J)	CP (pF) Typ.
	<10 μA		1 mA DC		1 A @ 8/20 μs	@ 8/20 μs	10/1000 μs	@ 1 MHz
CG0201MLA-5.5MH	4	5.5	8	14	28	—	—	32

## General Characteristics

Operating Temperature.....-40 °C to +85 °C  
 Storage Temperature.....-40 °C to +85 °C  
 Response Time..... <1 ns  
 Performance Standard ..... IEC 61000-4-2

## Environmental Characteristics

Characteristic	Specification	Test Condition
Bias Humidity	ΔVn/Vn ≤ 10 %	90 % RH, 40 °C, Working Voltage, 1000 Hours
Thermal Shock		-40 °C to +85 °C, 30 Minute Cycle, 5 Cycles Total
Load Test		Working Voltage, 85 °C, 1000 Hours

## Device Symbol

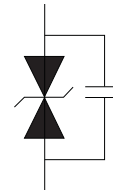

## How to Order

**CG 0201 MLA - 5.5 x H**

ChipGuard®  
 Product Designator  
 Package Designator  
 0201 = 0201 Package  
 Technology  
 MLA = Multilayer Varistor  
 Operating Voltage  
 5.5 = 5.5 V  
 Tolerance  
 M = 20 %  
 Tape & Reel Packaging  
 H = 15,000 pcs. per reel

# BOURNS®

Asia-Pacific: Tel: +886-2 2562-4117 • Fax: +886-2 2562-4116

EMEA: Tel: +36 88 520 390 • Fax: +36 88 520 211

The Americas: Tel: +1-951 781-5500 • Fax: +1-951 781-5700

[www.bourns.com](http://www.bourns.com)

\*RoHS Directive 2002/95/EC Jan. 27, 2003 including annex and RoHS Recast 2011/65/EU June 8, 2011. Specifications are subject to change without notice.

The device characteristics and parameters in this data sheet can and do vary in different applications and actual device performance may vary over time. Users should verify actual device performance in their specific applications.

# ChipGuard® MLA Series $\mu$ Varistor ESD Clamp Protector

**BOURNS®**

## Product Dimensions

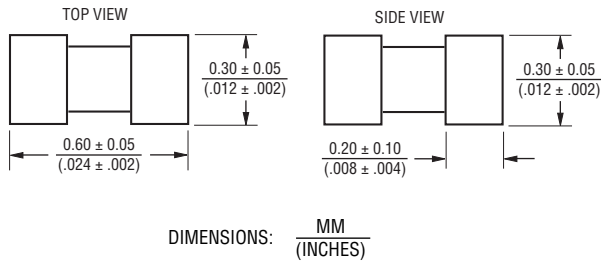

## Recommended Pad Layout

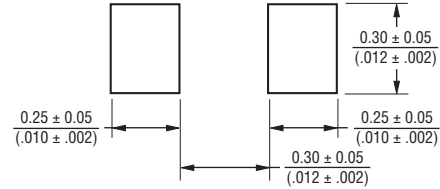

## Construction

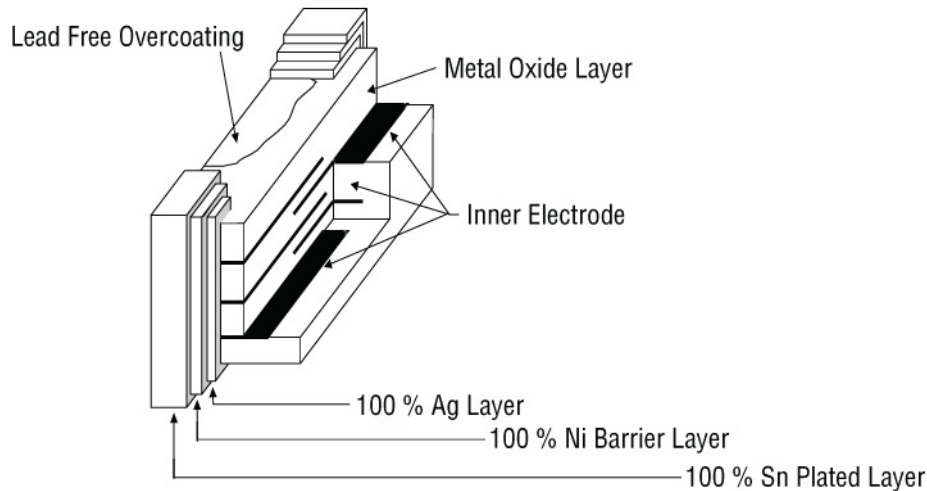

## Solder Reflow Recommendations

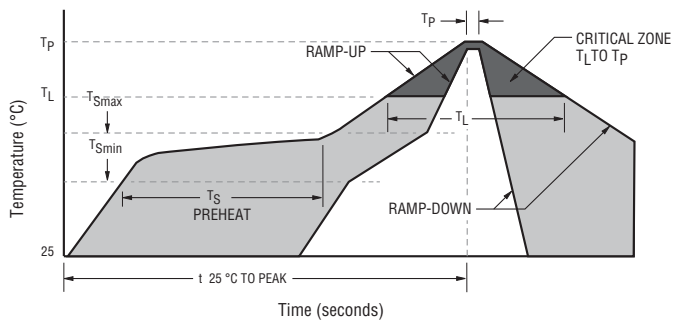

A	Stage 1 Preheat Ramp	Ambient to Preheating Temperature	3 °C / s max.
B	Stage 2 Preheat	Preheat min./max. Temperature Range	150 °C to 200 °C 60 s to 180 s
C	Stage 3 Preheat to Main Heating	Max. Time Above Stated Temperature	217 °C 60 s to 150 s
D	Main Heating	Max. Time Within 5 °C of Peak Temperature (260 °C)	255 °C 20 s to 40 s
E	Cool Down	Rate from Peak Temperature	6 °C / s max.

### CAUTION:

- Rapid heating and cooling in excess of stated maximum rates will easily damage this product.
- Locating heating can also damage product.
- Do not thermally shock product in excess of 100 °C.
- Product can be repaired using a 30 W or less solder gun/iron. Tip temperature maximum is 280 °C for less than 3 seconds.
- Do not touch the component directly with the soldering gun/iron.
- Excess soldering volumes can damage the body of the product.

Specifications are subject to change without notice.  
The device characteristics and parameters in this data sheet can and do vary in different applications and actual device performance may vary over time.  
Users should verify actual device performance in their specific applications.

# ChipGuard® MLA Series $\mu$ Varistor ESD Clamp Protector

**BOURNS®**

## Packaging Dimensions

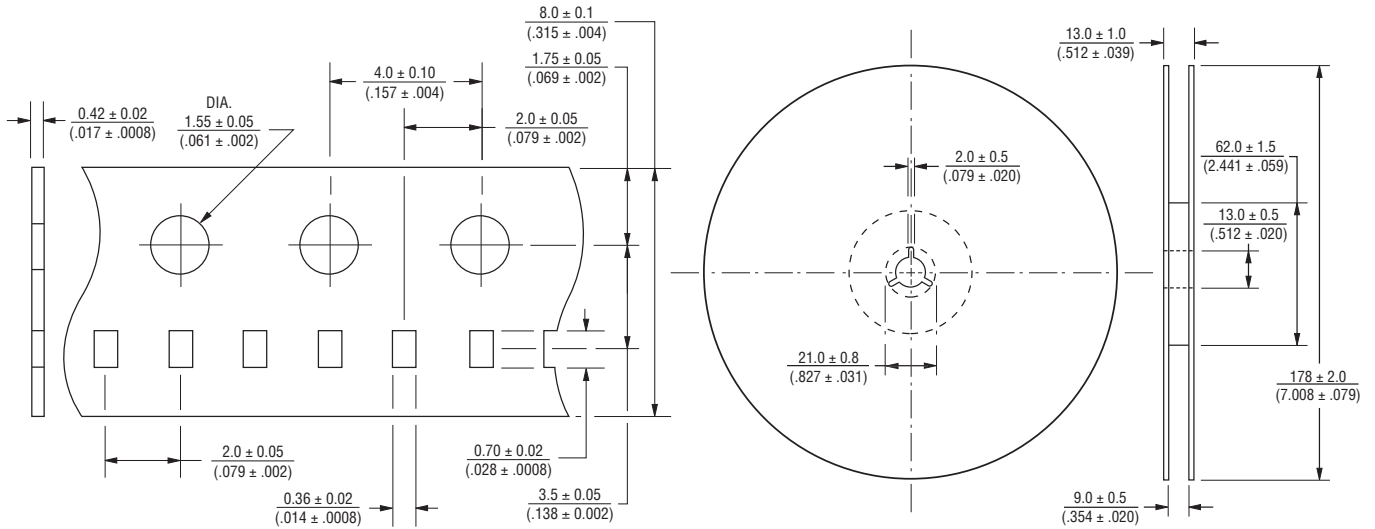

DIMENSIONS:  $\frac{\text{MM}}{\text{(INCHES)}}$

REV. A 07/14

Specifications are subject to change without notice.  
 The device characteristics and parameters in this data sheet can and do vary in different applications and actual device performance may vary over time.  
 Users should verify actual device performance in their specific applications.

## Looking for pricing, stock, or lifecycle information?

Click below to explore more details on WIN SOURCE:

-  [View CG0201MLA-5.5MH on WIN SOURCE](#)
-  [Bourns Inc. Information](#)

## Optimize Your Supply Chain with WIN SOURCE Solutions

-  Global Sourcing Solution
-  Obsolete Management
-  Cost Control Management
-  Shortage Management
-  Alternative Solution
-  Excess Inventory Management