



THE DATASHEET OF LM317DCYRG3



LM317 3-Terminal Adjustable Regulator

1 Features

- Output Voltage Range Adjustable
From 1.25 V to 37 V
- Output Current Greater Than 1.5 A
- Internal Short-Circuit Current Limiting
- Thermal Overload Protection
- Output Safe-Area Compensation

2 Applications

- ATCA Solutions
- DLP: 3D Biometrics, Hyperspectral Imaging, Optical Networking, and Spectroscopy
- DVR and DVS
- Desktop PC
- Digital Signage and Still Camera
- ECG Electrocardiogram
- EV HEV Charger: Level 1, 2, and 3
- Electronic Shelf Label
- Energy Harvesting
- Ethernet Switch
- Femto Base Station
- Fingerprint and Iris Biometrics
- HVAC: Heating, Ventilating, and Air Conditioning
- High-Speed Data Acquisition and Generation
- Hydraulic Valve
- IP Phone: Wired and Wireless
- Intelligent Occupancy Sensing
- Motor Control: Brushed DC, Brushless DC, Low-Voltage, Permanent Magnet, and Stepper Motor
- Point-to-Point Microwave Backhaul
- Power Bank Solutions
- Power Line Communication Modem
- Power Over Ethernet (PoE)
- Power Quality Meter
- Power Substation Control
- Private Branch Exchange (PBX)
- Programmable Logic Controller
- RFID Reader
- Refrigerator
- Signal or Waveform Generator
- Software Defined Radio (SDR)
- Washing Machine: High-End and Low-End
- X-ray: Baggage Scanner, Medical, and Dental

3 Description

The LM317 device is an adjustable three-terminal positive-voltage regulator capable of supplying more than 1.5 A over an output-voltage range of 1.25 V to 37 V. It requires only two external resistors to set the output voltage. The device features a typical line regulation of 0.01% and typical load regulation of 0.1%. It includes current limiting, thermal overload protection, and safe operating area protection. Overload protection remains functional even if the ADJUST terminal is disconnected.

Device Information⁽¹⁾

PART NUMBER	PACKAGE	BODY SIZE (NOM)
LM317DCY	SOT-223 (4)	6.50 mm × 3.50 mm
LM317KCS	TO-220 (3)	10.16 mm × 9.15 mm
LM317KCT	TO-220 (3)	10.16 mm × 8.59 mm
LM317KTT	TO-263 (3)	10.16 mm × 9.01 mm

(1) For all available packages, see the orderable addendum at the end of the data sheet.

Battery-Charger Circuit

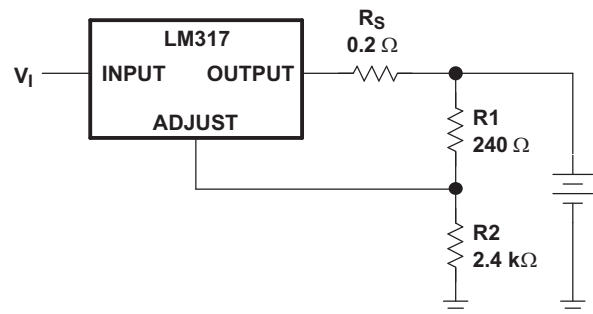

Copyright © 2016, Texas Instruments Incorporated



Table of Contents

1 Features	1	7.4 Device Functional Modes.....	9
2 Applications	1	8 Application and Implementation	10
3 Description	1	8.1 Application Information.....	10
4 Revision History	2	8.2 Typical Application	10
5 Pin Configuration and Functions	3	8.3 System Examples	11
6 Specifications	4	9 Power Supply Recommendations	18
6.1 Absolute Maximum Ratings	4	10 Layout	18
6.2 ESD Ratings.....	4	10.1 Layout Guidelines	18
6.3 Recommended Operating Conditions.....	4	10.2 Layout Example	18
6.4 Thermal Information	4	11 Device and Documentation Support	19
6.5 Electrical Characteristics.....	5	11.1 Receiving Notification of Documentation Updates	19
6.6 Typical Characteristics	6	11.2 Community Resources.....	19
7 Detailed Description	8	11.3 Trademarks	19
7.1 Overview	8	11.4 Electrostatic Discharge Caution.....	19
7.2 Functional Block Diagram	8	11.5 Glossary	19
7.3 Feature Description.....	8	12 Mechanical, Packaging, and Orderable Information	19

4 Revision History

Changes from Revision W (January 2015) to Revision X

Page

• Changed body size dimensions for KCS TO-220 Package on <i>Device information</i> table	1
• Changed body size dimensions for KTT TO-263 Package on <i>Device information</i> table	1
• Changed V_O Output Voltage max value from 7 to 37 on <i>Recommended Operating Conditions</i> table	4
• Added min value to I_O Output Current in <i>Recommended Operating Conditions</i> table	4
• Changed values in the Thermal Information table to align with JEDEC standards	4
• Added KCT package data to <i>Thermal Information</i> table	4
• Deleted Section 9.3.6 "Adjusting Multiple On-Card Regulators with a Single Control"	13
• Updated Adjustable 4-A Regulator Circuit graphic	16
• Added <i>Receiving Notification of Documentation Updates</i> section and <i>Community Resources</i> section	19

Changes from Revision V (February 2013) to Revision W

Page

• Added <i>Applications</i> , <i>Device Information</i> table, <i>Pin Functions</i> table, <i>ESD Ratings</i> table, <i>Thermal Information</i> table, <i>Feature Description</i> section, <i>Device Functional Modes</i> , <i>Application and Implementation</i> section, <i>Power Supply Recommendations</i> section, <i>Layout</i> section, <i>Device and Documentation Support</i> section, and <i>Mechanical, Packaging, and Orderable Information</i> section.	1
• Deleted <i>Ordering Information</i> table.	1

5 Pin Configuration and Functions

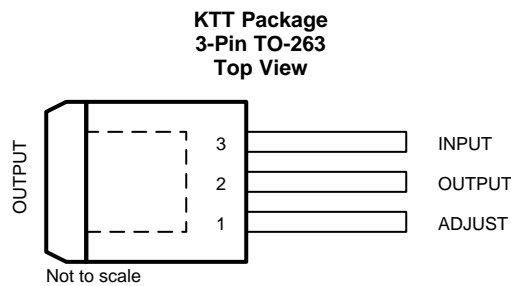
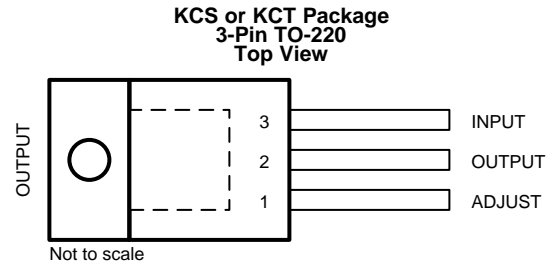
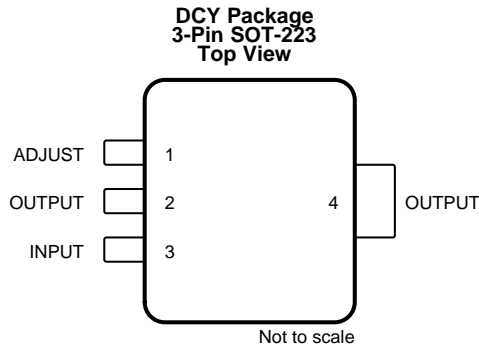

Pin Functions

NAME	PIN		I/O	DESCRIPTION
	TO-263, TO-220	SOT-223		
ADJUST	1	1	I	Output voltage adjustment pin. Connect to a resistor divider to set V_O
INPUT	3	3	I	Supply input pin
OUTPUT	2	2, 4	O	Voltage output pin

6 Specifications

6.1 Absolute Maximum Ratings

over virtual junction temperature range (unless otherwise noted)⁽¹⁾

		MIN	MAX	UNIT
$V_I - V_O$	Input-to-output differential voltage		40	V
T_J	Operating virtual junction temperature		150	°C
	Lead temperature 1,6 mm (1/16 in) from case for 10 s		260	°C
T_{stg}	Storage temperature	-65	150	°C

- (1) Stresses beyond those listed under *Absolute Maximum Ratings* may cause permanent damage to the device. These are stress ratings only, and functional operation of the device at these or any other conditions beyond those indicated under *Recommended Operating Conditions* is not implied. Exposure to absolute-maximum-rated conditions for extended periods may affect device reliability.

6.2 ESD Ratings

		MAX	UNIT
$V_{(ESD)}$	Electrostatic discharge	Human body model (HBM), per ANSI/ESDA/JEDEC JS-001 ⁽¹⁾	2500
		Charged device model (CDM), per JEDEC specification JESD22-C101 ⁽²⁾	1000

- (1) JEDEC document JEP155 states that 500-V HBM allows safe manufacturing with a standard ESD control process.
 (2) JEDEC document JEP157 states that 250-V CDM allows safe manufacturing with a standard ESD control process.

6.3 Recommended Operating Conditions

		MIN	MAX	UNIT
V_O	Output voltage	1.25	37	V
$V_I - V_O$	Input-to-output differential voltage	3	40	V
I_O	Output current	0.01	1.5	A
T_J	Operating virtual junction temperature	0	125	°C

6.4 Thermal Information

THERMAL METRIC ⁽¹⁾	LM317				UNIT	
	DCY (SOT-223)	KCS (TO-220)	KCT (TO-220)	KTT (TO-263)		
	4 PINS	3 PINS	3 PINS	3 PINS		
$R_{\theta(JA)}$	Junction-to-ambient thermal resistance	66.8	23.5	37.9	38.0	°C/W
$R_{\theta(JC(top))}$	Junction-to-case (top) thermal resistance	43.2	15.9	51.1	36.5	°C/W
$R_{\theta(JB)}$	Junction-to-board thermal resistance	16.9	7.9	23.2	18.9	°C/W
Ψ_{JT}	Junction-to-top characterization parameter	3.6	3.0	13.0	6.9	°C/W
Ψ_{JB}	Junction-to-board characterization parameter	16.8	7.8	22.8	17.9	°C/W
$R_{\theta(JC(bot))}$	Junction-to-case (bottom) thermal resistance	NA	0.1	4.2	1.1	°C/W

- (1) For more information about traditional and new thermal metrics, see the *Semiconductor and IC Package Thermal Metrics* application report.

6.5 Electrical Characteristics

over recommended ranges of operating virtual junction temperature (unless otherwise noted)

PARAMETER	TEST CONDITIONS ⁽¹⁾		MIN	TYP	MAX	UNIT
Line regulation ⁽²⁾	$V_I - V_O = 3\text{ V to }40\text{ V}$		$T_J = 25^\circ\text{C}$	0.01	0.04	%V
			$T_J = 0^\circ\text{C to }125^\circ\text{C}$	0.02	0.07	
Load regulation	$I_O = 10\text{ mA to }1500\text{ mA}$	$C_{ADJ}^{(3)} = 10\ \mu\text{F},$ $T_J = 25^\circ\text{C}$	$V_O \leq 5\text{ V}$		25	mV
			$V_O \geq 5\text{ V}$	0.1	0.5	% V_O
		$T_J = 0^\circ\text{C to }125^\circ\text{C}$	$V_O \leq 5\text{ V}$	20	70	mV
			$V_O \geq 5\text{ V}$	0.3	1.5	% V_O
Thermal regulation	20-ms pulse,	$T_J = 25^\circ\text{C}$		0.03	0.07	% V_O/W
ADJUST terminal current				50	100	μA
Change in ADJUST terminal current	$V_I - V_O = 2.5\text{ V to }40\text{ V}, P_D \leq 20\text{ W}, I_O = 10\text{ mA to }1500\text{ mA}$			0.2	5	μA
Reference voltage	$V_I - V_O = 3\text{ V to }40\text{ V}, P_D \leq 20\text{ W}, I_O = 10\text{ mA to }1500\text{ mA}$		1.2	1.25	1.3	V
Output-voltage temperature stability	$T_J = 0^\circ\text{C to }125^\circ\text{C}$			0.7		% V_O
Minimum load current to maintain regulation	$V_I - V_O = 40\text{ V}$			3.5	10	mA
Maximum output current	$V_I - V_O \leq 15\text{ V},$	$P_D < P_{MAX}^{(4)}$	1.5	2.2		A
	$V_I - V_O \leq 40\text{ V},$	$P_D < P_{MAX}^{(4)},$ $T_J = 25^\circ\text{C}$	0.15	0.4		
RMS output noise voltage (% of V_O)	$f = 10\text{ Hz to }10\text{ kHz},$	$T_J = 25^\circ\text{C}$		0.003		% V_O
Ripple rejection	$V_O = 10\text{ V},$	$f = 120\text{ Hz}$	$C_{ADJ} = 0\ \mu\text{F}^{(3)}$	57		dB
			$C_{ADJ} = 10\ \mu\text{F}^{(3)}$	62	64	
Long-term stability	$T_J = 25^\circ\text{C}$			0.3	1	%/1k hr

- (1) Unless otherwise noted, the following test conditions apply: $|V_I - V_O| = 5\text{ V}$ and $I_{O\text{MAX}} = 1.5\text{ A}$, $T_J = 0^\circ\text{C to }125^\circ\text{C}$. Pulse testing techniques are used to maintain the junction temperature as close to the ambient temperature as possible.
- (2) Line regulation is expressed here as the percentage change in output voltage per 1-V change at the input.
- (3) C_{ADJ} is connected between the ADJUST terminal and GND.
- (4) Maximum power dissipation is a function of $T_J(\text{max})$, θ_{JA} , and T_A . The maximum allowable power dissipation at any allowable ambient temperature is $P_D = (T_J(\text{max}) - T_A) / \theta_{JA}$. Operating at the absolute maximum T_J of 150°C can affect reliability.

6.6 Typical Characteristics

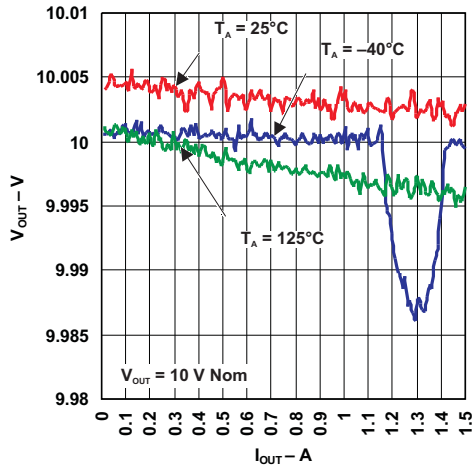

Figure 1. Load Regulation

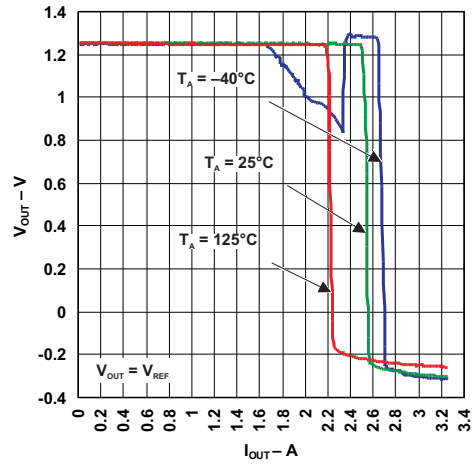

Figure 2. Load Regulation

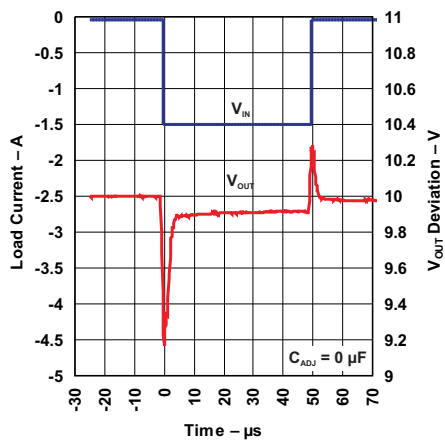

Figure 3. Load Transient Response

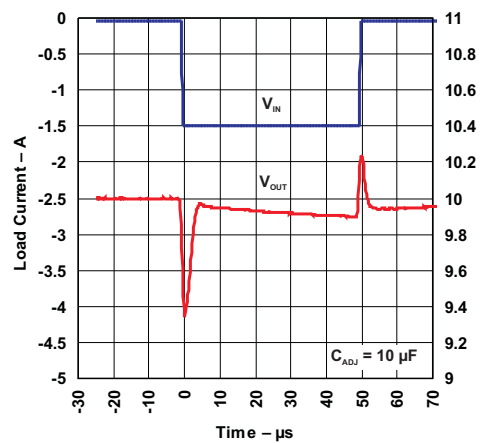

Figure 4. Load Transient Response

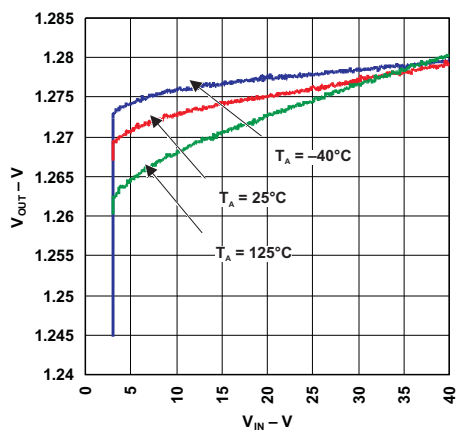

Figure 5. Line Regulation

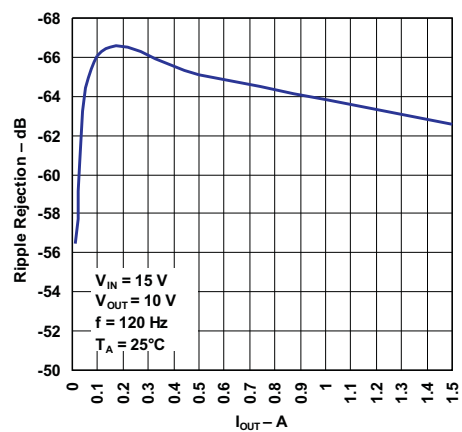

Figure 6. Ripple Rejection vs Output Current

Typical Characteristics (continued)

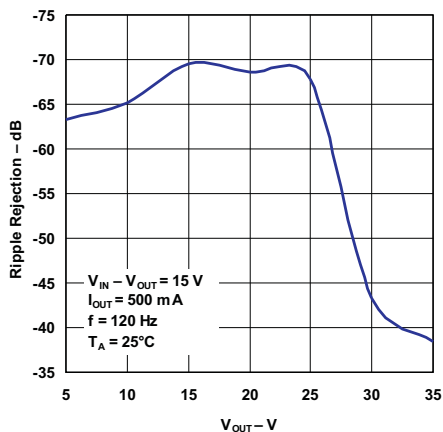

Figure 7. Ripple Rejection vs Output Voltage

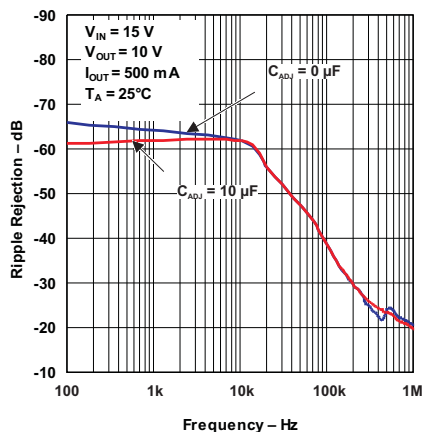

Figure 8. Ripple Rejection vs Frequency

7 Detailed Description

7.1 Overview

The LM317 device is an adjustable three-terminal positive-voltage regulator capable of supplying up to 1.5 A over an output-voltage range of 1.25 V to 37 V. It requires only two external resistors to set the output voltage. The device features a typical line regulation of 0.01% and typical load regulation of 0.1%. It includes current limiting, thermal overload protection, and safe operating area protection. Overload protection remains functional even if the ADJUST terminal is disconnected.

The LM317 device is versatile in its applications, including uses in programmable output regulation and local on-card regulation. Or, by connecting a fixed resistor between the ADJUST and OUTPUT terminals, the LM317 device can function as a precision current regulator. An optional output capacitor can be added to improve transient response. The ADJUST terminal can be bypassed to achieve very high ripple-rejection ratios, which are difficult to achieve with standard three-terminal regulators.

7.2 Functional Block Diagram

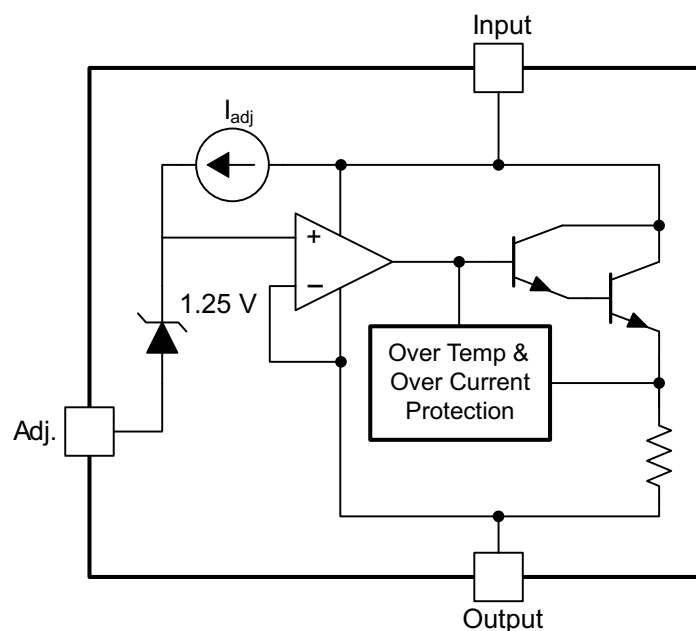

7.3 Feature Description

7.3.1 NPN Darlington Output Drive

NPN Darlington output topology provides naturally low output impedance and an output capacitor is optional. 3-V headroom is recommended ($V_I - V_O$) to support maximum current and lowest temperature.

7.3.2 Overload Block

Over-current and over-temperature shutdown protects the device against overload or damage from operating in excessive heat.

7.3.3 Programmable Feedback

Op amp with 1.25-V offset input at the ADJUST terminal provides easy output voltage or current (not both) programming. For current regulation applications, a single resistor whose resistance value is $1.25 \text{ V}/I_O$ and power rating is greater than $(1.25 \text{ V})^2/R$ should be used. For voltage regulation applications, two resistors set the output voltage.

7.4 Device Functional Modes

7.4.1 Normal Operation

The device OUTPUT pin will source current necessary to make OUTPUT pin 1.25 V greater than ADJUST terminal to provide output regulation.

7.4.2 Operation With Low Input Voltage

The device requires up to 3-V headroom ($V_I - V_O$) to operate in regulation. The device may drop out and OUTPUT voltage will be INPUT voltage minus drop out voltage with less headroom.

7.4.3 Operation at Light Loads

The device passes its bias current to the OUTPUT pin. The load or feedback must consume this minimum current for regulation or the output may be too high. See the [Electrical Characteristics](#) table for the minimum load current needed to maintain regulation.

7.4.4 Operation In Self Protection

When an overload occurs the device shuts down Darlington NPN output stage or reduces the output current to prevent device damage. The device will automatically reset from the overload. The output may be reduced or alternate between on and off until the overload is removed.

8 Application and Implementation

NOTE

Information in the following applications sections is not part of the TI component specification, and TI does not warrant its accuracy or completeness. TI's customers are responsible for determining suitability of components for their purposes. Customers should validate and test their design implementation to confirm system functionality.

8.1 Application Information

The flexibility of the LM317 allows it to be configured to take on many different functions in DC power applications.

8.2 Typical Application

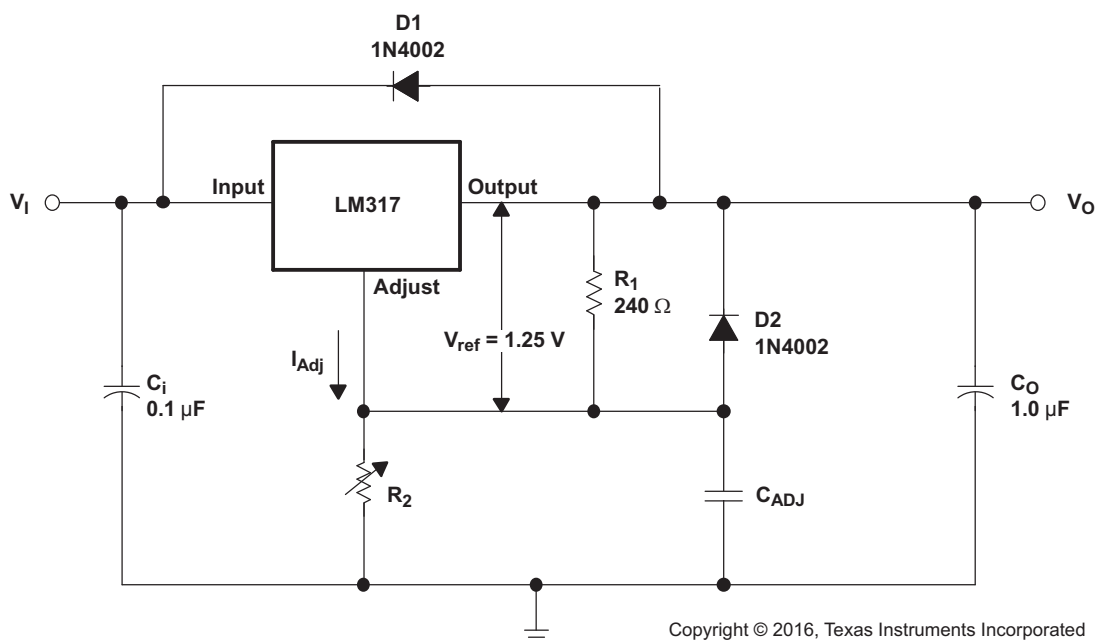

Figure 9. Adjustable Voltage Regulator

8.2.1 Design Requirements

- R₁ and R₂ are required to set the output voltage.
- C_{ADJ} is recommended to improve ripple rejection. It prevents amplification of the ripple as the output voltage is adjusted higher.
- C_i is recommended, particularly if the regulator is not in close proximity to the power-supply filter capacitors. A 0.1-μF or 1-μF ceramic or tantalum capacitor provides sufficient bypassing for most applications, especially when adjustment and output capacitors are used.
- C_O improves transient response, but is not needed for stability.
- Protection diode D₂ is recommended if C_{ADJ} is used. The diode provides a low-impedance discharge path to prevent the capacitor from discharging into the output of the regulator.
- Protection diode D₁ is recommended if C_O is used. The diode provides a low-impedance discharge path to prevent the capacitor from discharging into the output of the regulator.

8.2.2 Detailed Design Procedure

V_O is calculated as shown in [Equation 1](#). I_{ADJ} is typically 50 μA and negligible in most applications.

$$V_O = V_{REF} (1 + R_2 / R_1) + (I_{ADJ} \times R_2) \quad (1)$$

Typical Application (continued)

8.2.3 Application Curves

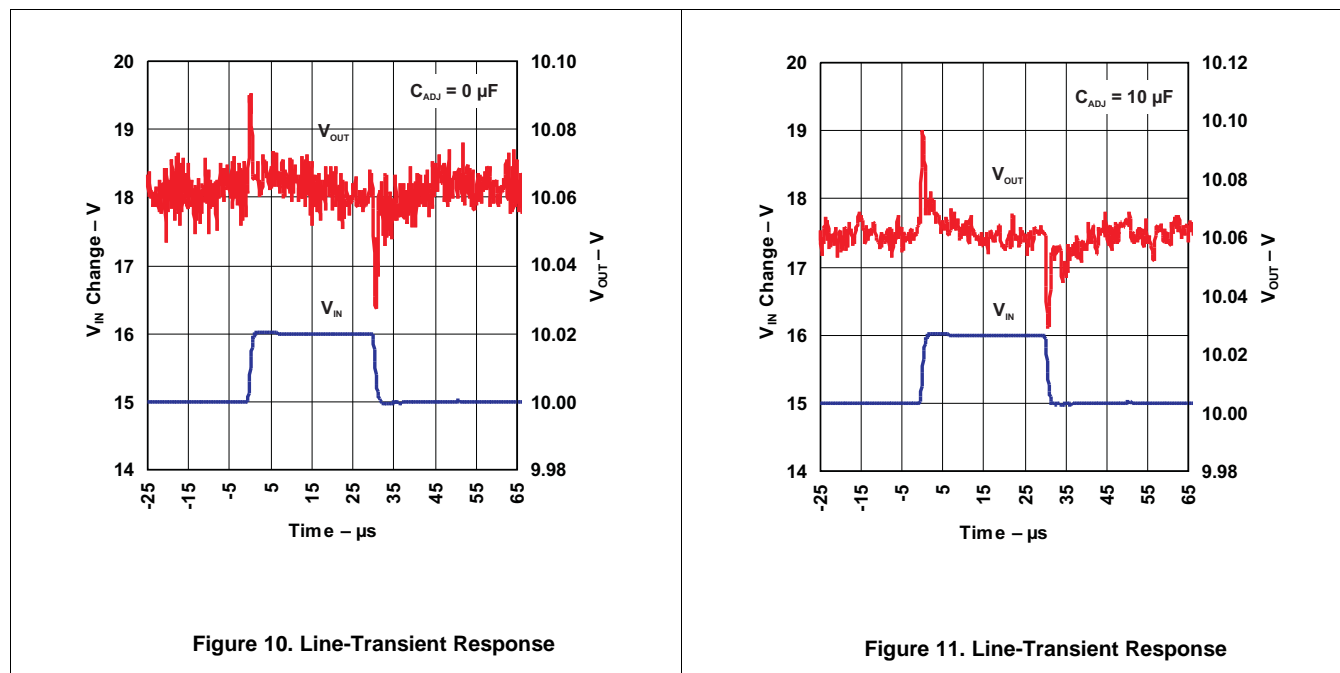

Figure 10. Line-Transient Response

Figure 11. Line-Transient Response

8.3 System Examples

8.3.1 0-V to 30-V Regulator Circuit

Here, the voltage is determined by
$$V_{OUT} = V_{REF} \left(1 + \frac{R_2 + R_3}{R_1} \right) - 10V$$

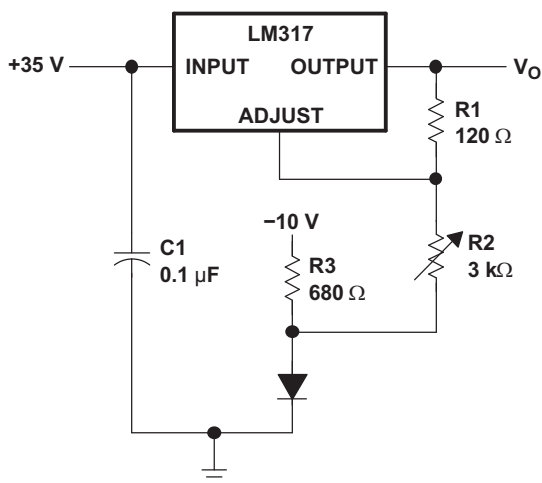

Figure 12. 0-V to 30-V Regulator Circuit

System Examples (continued)

8.3.2 Adjustable Regulator Circuit With Improved Ripple Rejection

C2 helps to stabilize the voltage at the adjustment pin, which helps reject noise. Diode D1 exists to discharge C2 in case the output is shorted to ground.

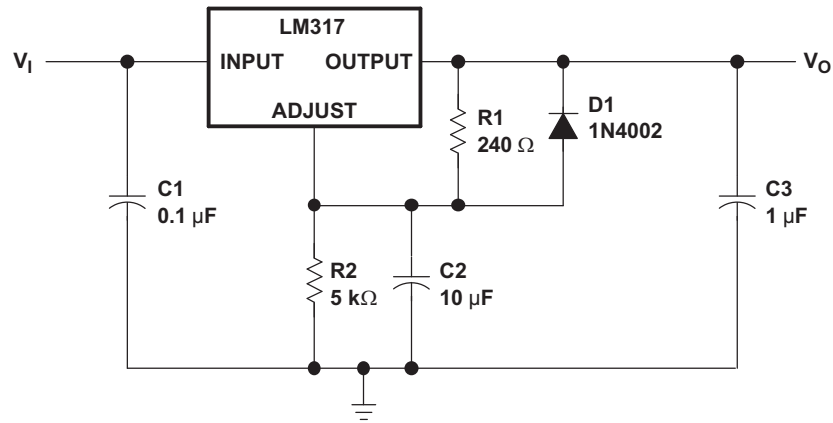

Figure 13. Adjustable Regulator Circuit with Improved Ripple Rejection

8.3.3 Precision Current-Limiter Circuit

This application limits the output current to the I_{LIMIT} in the diagram.

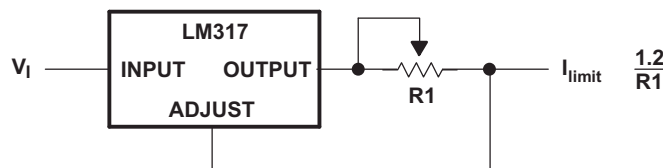

Figure 14. Precision Current-Limiter Circuit

8.3.4 Tracking Preregulator Circuit

This application keeps a constant voltage across the second LM317 in the circuit.

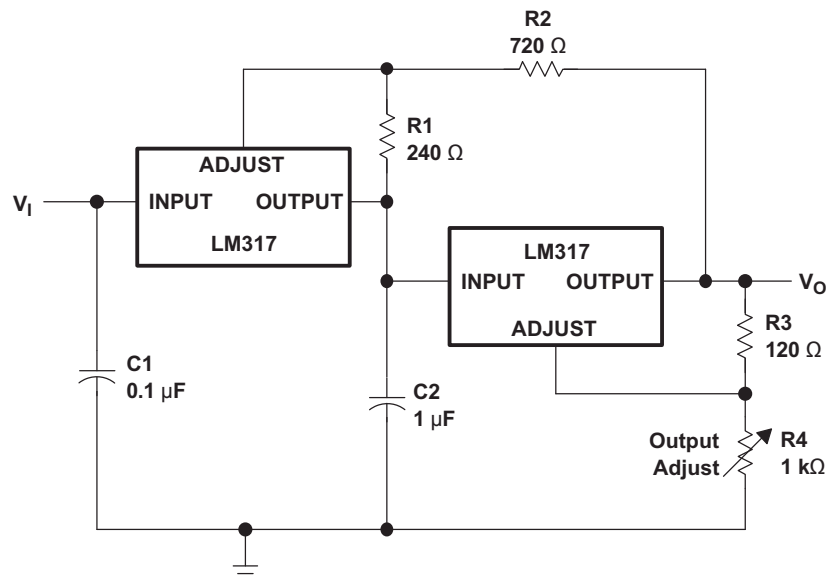

Figure 15. Tracking Preregulator Circuit

System Examples (continued)

8.3.5 1.25-V to 20-V Regulator Circuit With Minimum Program Current

Because the value of V_{REF} is constant, the value of R_1 determines the amount of current that flows through R_1 and R_2 . The size of R_2 determines the IR drop from ADJUSTMENT to GND. Higher values of R_2 translate to higher V_{OUT} .

$$V_{OUT} = V_{REF} \left(1 + \frac{R_2 + R_3}{R_1} \right) - 10V \tag{2}$$

$$(R_1 + R_2)_{min} = V_{olreg(min)} \tag{3}$$

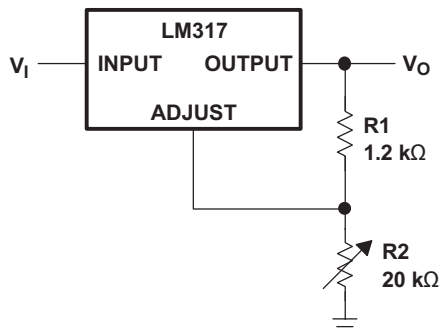

Figure 16. 1.25-V to 20-V Regulator Circuit With Minimum Program Current

8.3.6 Battery-Charger Circuit

The series resistor limits the current output of the LM317, minimizing damage to the battery cell.

$$V_{OUT} = 1.25V \times \left(\frac{R_2}{R_1 + 1} \right) \tag{4}$$

$$I_{OUT(short)} = \frac{1.25V}{R_S} \tag{5}$$

$$\text{Output impedance} = R_S \times \left(\frac{R_2}{R_1 + 1} \right) \tag{6}$$

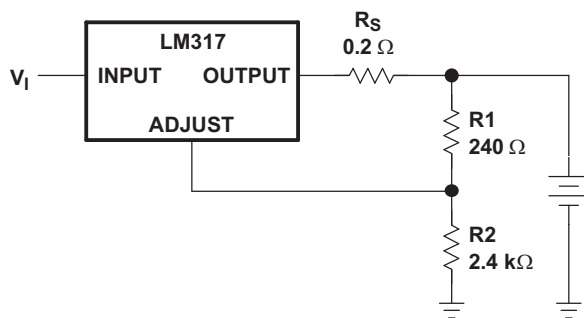

Copyright © 2016, Texas Instruments Incorporated

Figure 17. Battery-Charger Circuit

System Examples (continued)

8.3.7 50-mA Constant-Current Battery-Charger Circuit

The current limit operation mode can be used to trickle charge a battery at a fixed current. $I_{CHG} = 1.25 \text{ V} \div 24 \Omega$. V_I should be greater than $V_{BAT} + 4.25 \text{ V}$. (1.25 V [V_{REF}] + 3 V [headroom])

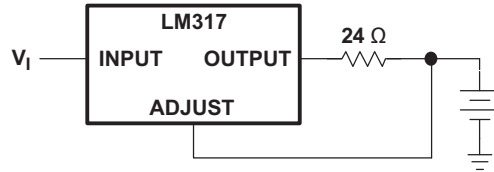

Figure 18. 50-mA Constant-Current Battery-Charger Circuit

8.3.8 Slow Turn-On 15-V Regulator Circuit

The capacitor C1, in combination with the PNP transistor, helps the circuit to slowly start supplying voltage. In the beginning, the capacitor is not charged. Therefore output voltage starts at $V_{C1} + V_{BE} + 1.25 \text{ V} = 0 \text{ V} + 0.65 \text{ V} + 1.25 \text{ V} = 1.9 \text{ V}$. As the capacitor voltage rises, V_{OUT} rises at the same rate. When the output voltage reaches the value determined by R1 and R2, the PNP will be turned off.

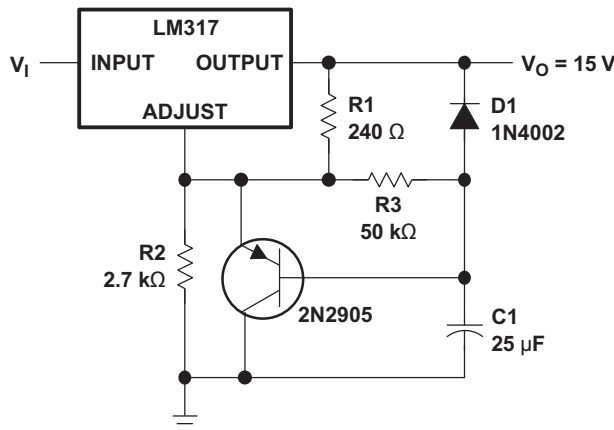

Figure 19. Slow Turn-On 15-V Regulator Circuit

8.3.9 AC Voltage-Regulator Circuit

These two LM317s can regulate both the positive and negative swings of a sinusoidal AC input.

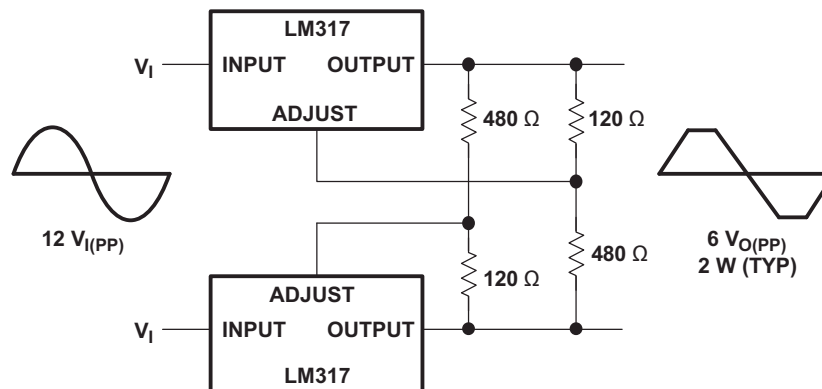

Figure 20. AC Voltage-Regulator Circuit

System Examples (continued)

8.3.10 Current-Limited 6-V Charger Circuit

As the charge current increases, the voltage at the bottom resistor increases until the NPN starts sinking current from the adjustment pin. The voltage at the adjustment pin drops, and consequently the output voltage decreases until the NPN stops conducting.

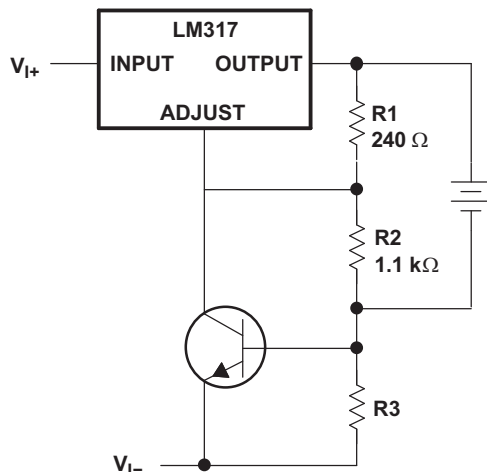
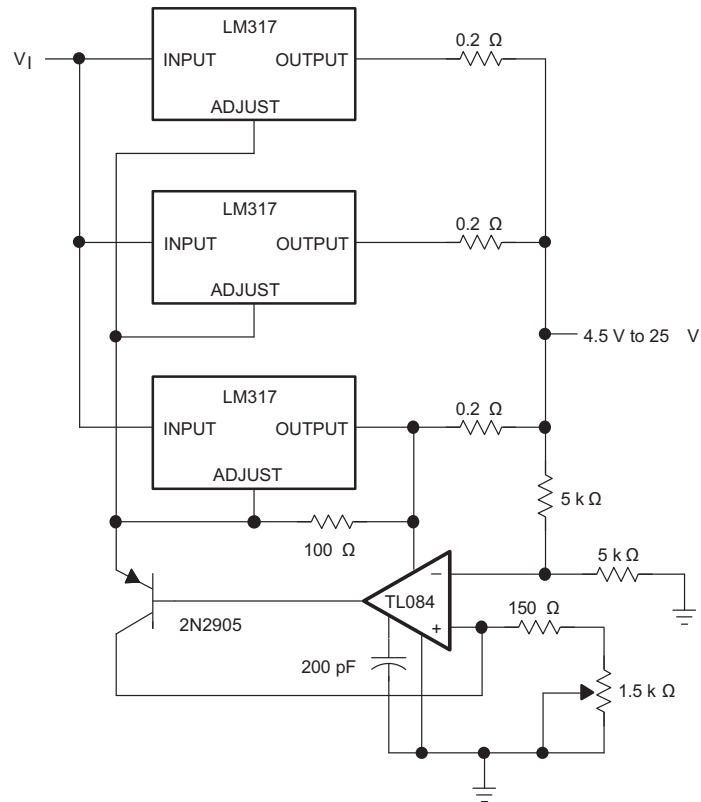

Figure 21. Current-Limited 6-V Charger Circuit

8.3.11 Adjustable 4-A Regulator Circuit

This application keeps the output current at 4 A while having the ability to adjust the output voltage using the adjustable (1.5 kΩ in schematic) resistor.

System Examples (continued)



Copyright © 2016, Texas Instruments Incorporated

Figure 22. Adjustable 4-A Regulator Circuit

System Examples (continued)

8.3.12 High-Current Adjustable Regulator Circuit

The NPNs at the top of the schematic allow higher currents at V_{OUT} than the LM317 can provide, while still keeping the output voltage at levels determined by the adjustment pin resistor divider of the LM317.

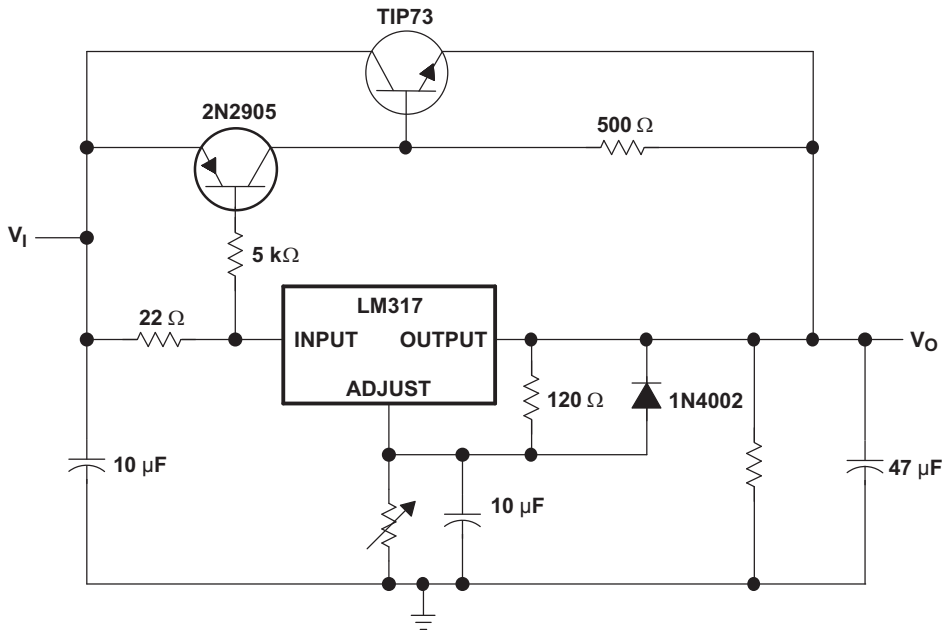

Figure 23. High-Current Adjustable Regulator Circuit

9 Power Supply Recommendations

The LM317 is designed to operate from an input voltage supply range between 1.25 V to 37 V greater than the output voltage. If the device is more than six inches from the input filter capacitors, an input bypass capacitor, 0.1 μF or greater, of any type is needed for stability.

10 Layout

10.1 Layout Guidelines

- TI recommends that the input terminal be bypassed to ground with a bypass capacitor.
- The optimum placement is closest to the input terminal of the device and the system GND. Take care to minimize the loop area formed by the bypass-capacitor connection, the input terminal, and the system GND.
- For operation at full rated load, TI recommends to use wide trace lengths to eliminate $I \times R$ drop and heat dissipation.

10.2 Layout Example

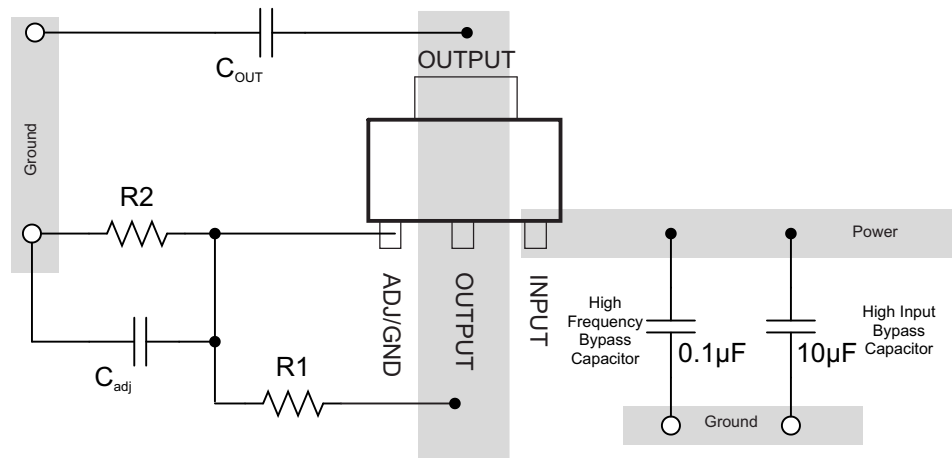

Figure 24. Layout Example

11 Device and Documentation Support

11.1 Receiving Notification of Documentation Updates

To receive notification of documentation updates, navigate to the device product folder on ti.com. In the upper right corner, click on *Alert me* to register and receive a weekly digest of any product information that has changed. For change details, review the revision history included in any revised document.

11.2 Community Resources

The following links connect to TI community resources. Linked contents are provided "AS IS" by the respective contributors. They do not constitute TI specifications and do not necessarily reflect TI's views; see TI's [Terms of Use](#).

TI E2E™ Online Community *TI's Engineer-to-Engineer (E2E) Community*. Created to foster collaboration among engineers. At e2e.ti.com, you can ask questions, share knowledge, explore ideas and help solve problems with fellow engineers.

Design Support *TI's Design Support* Quickly find helpful E2E forums along with design support tools and contact information for technical support.

11.3 Trademarks

E2E is a trademark of Texas Instruments.
All other trademarks are the property of their respective owners.

11.4 Electrostatic Discharge Caution



This integrated circuit can be damaged by ESD. Texas Instruments recommends that all integrated circuits be handled with appropriate precautions. Failure to observe proper handling and installation procedures can cause damage.

ESD damage can range from subtle performance degradation to complete device failure. Precision integrated circuits may be more susceptible to damage because very small parametric changes could cause the device not to meet its published specifications.

11.5 Glossary

[SLYZ022](#) — *TI Glossary*.

This glossary lists and explains terms, acronyms, and definitions.

12 Mechanical, Packaging, and Orderable Information

The following pages include mechanical, packaging, and orderable information. This information is the most current data available for the designated devices. This data is subject to change without notice and revision of this document. For browser-based versions of this data sheet, refer to the left-hand navigation.

PACKAGING INFORMATION

Orderable Device	Status (1)	Package Type	Package Drawing	Pins	Package Qty	Eco Plan (2)	Lead/Ball Finish (6)	MSL Peak Temp (3)	Op Temp (°C)	Device Marking (4/5)	Samples
LM317DCY	ACTIVE	SOT-223	DCY	4	80	Green (RoHS & no Sb/Br)	CU SN	Level-2-260C-1 YEAR	0 to 125	L3	Samples
LM317DCYG3	ACTIVE	SOT-223	DCY	4	80	Green (RoHS & no Sb/Br)	CU SN	Level-2-260C-1 YEAR	0 to 125	L3	Samples
LM317DCYR	ACTIVE	SOT-223	DCY	4	2500	Green (RoHS & no Sb/Br)	CU SN	Level-2-260C-1 YEAR	0 to 125	L3	Samples
LM317DCYRG3	ACTIVE	SOT-223	DCY	4	2500	Green (RoHS & no Sb/Br)	CU SN	Level-2-260C-1 YEAR	0 to 125	L3	Samples
LM317KCS	ACTIVE	TO-220	KCS	3	50	Pb-Free (RoHS)	CU SN	N / A for Pkg Type	0 to 125	LM317	Samples
LM317KCSE3	ACTIVE	TO-220	KCS	3	50	Pb-Free (RoHS)	CU SN	N / A for Pkg Type	0 to 125	LM317	Samples
LM317KCT	ACTIVE	TO-220	KCT	3	50	Pb-Free (RoHS)	CU SN	N / A for Pkg Type	0 to 125	LM317	Samples
LM317KTTR	ACTIVE	DDPAK/ TO-263	KTT	3	500	Green (RoHS & no Sb/Br)	CU SN	Level-3-245C-168 HR	0 to 125	LM317	Samples
LM317KTTRG3	ACTIVE	DDPAK/ TO-263	KTT	3	500	Green (RoHS & no Sb/Br)	CU SN	Level-3-245C-168 HR	0 to 125	LM317	Samples

(1) The marketing status values are defined as follows:

ACTIVE: Product device recommended for new designs.

LIFEBUY: TI has announced that the device will be discontinued, and a lifetime-buy period is in effect.

NRND: Not recommended for new designs. Device is in production to support existing customers, but TI does not recommend using this part in a new design.

PREVIEW: Device has been announced but is not in production. Samples may or may not be available.

OBSOLETE: TI has discontinued the production of the device.

(2) Eco Plan - The planned eco-friendly classification: Pb-Free (RoHS), Pb-Free (RoHS Exempt), or Green (RoHS & no Sb/Br) - please check <http://www.ti.com/productcontent> for the latest availability information and additional product content details.

TBD: The Pb-Free/Green conversion plan has not been defined.

Pb-Free (RoHS): TI's terms "Lead-Free" or "Pb-Free" mean semiconductor products that are compatible with the current RoHS requirements for all 6 substances, including the requirement that lead not exceed 0.1% by weight in homogeneous materials. Where designed to be soldered at high temperatures, TI Pb-Free products are suitable for use in specified lead-free processes.

Pb-Free (RoHS Exempt): This component has a RoHS exemption for either 1) lead-based flip-chip solder bumps used between the die and package, or 2) lead-based die adhesive used between the die and leadframe. The component is otherwise considered Pb-Free (RoHS compatible) as defined above.

Green (RoHS & no Sb/Br): TI defines "Green" to mean Pb-Free (RoHS compatible), and free of Bromine (Br) and Antimony (Sb) based flame retardants (Br or Sb do not exceed 0.1% by weight in homogeneous material)

- (3) MSL, Peak Temp. - The Moisture Sensitivity Level rating according to the JEDEC industry standard classifications, and peak solder temperature.
- (4) There may be additional marking, which relates to the logo, the lot trace code information, or the environmental category on the device.
- (5) Multiple Device Markings will be inside parentheses. Only one Device Marking contained in parentheses and separated by a "-" will appear on a device. If a line is indented then it is a continuation of the previous line and the two combined represent the entire Device Marking for that device.
- (6) Lead/Ball Finish - Orderable Devices may have multiple material finish options. Finish options are separated by a vertical ruled line. Lead/Ball Finish values may wrap to two lines if the finish value exceeds the maximum column width.

Important Information and Disclaimer:The information provided on this page represents TI's knowledge and belief as of the date that it is provided. TI bases its knowledge and belief on information provided by third parties, and makes no representation or warranty as to the accuracy of such information. Efforts are underway to better integrate information from third parties. TI has taken and continues to take reasonable steps to provide representative and accurate information but may not have conducted destructive testing or chemical analysis on incoming materials and chemicals. TI and TI suppliers consider certain information to be proprietary, and thus CAS numbers and other limited information may not be available for release.

In no event shall TI's liability arising out of such information exceed the total purchase price of the TI part(s) at issue in this document sold by TI to Customer on an annual basis.

TAPE AND REEL INFORMATION

QUADRANT ASSIGNMENTS FOR PIN 1 ORIENTATION IN TAPE

*All dimensions are nominal

Device	Package Type	Package Drawing	Pins	SPQ	Reel Diameter (mm)	Reel Width W1 (mm)	A0 (mm)	B0 (mm)	K0 (mm)	P1 (mm)	W (mm)	Pin1 Quadrant
LM317DCYR	SOT-223	DCY	4	2500	330.0	12.4	7.0	7.42	2.0	8.0	12.0	Q3
LM317DCYR	SOT-223	DCY	4	2500	330.0	12.4	7.05	7.4	1.9	8.0	12.0	Q3
LM317DCYR	SOT-223	DCY	4	2500	330.0	12.4	6.55	7.25	1.9	8.0	12.0	Q3
LM317KTTR	DDPAK/ TO-263	KTT	3	500	330.0	24.4	10.8	16.1	4.9	16.0	24.0	Q2

TAPE AND REEL BOX DIMENSIONS

*All dimensions are nominal

Device	Package Type	Package Drawing	Pins	SPQ	Length (mm)	Width (mm)	Height (mm)
LM317DCYR	SOT-223	DCY	4	2500	350.0	334.0	47.0
LM317DCYR	SOT-223	DCY	4	2500	340.0	340.0	38.0
LM317DCYR	SOT-223	DCY	4	2500	336.0	336.0	48.0
LM317KTTR	DDPAK/TO-263	KTT	3	500	350.0	334.0	47.0

KTT (R-PSFM-G3)

PLASTIC FLANGE-MOUNT PACKAGE

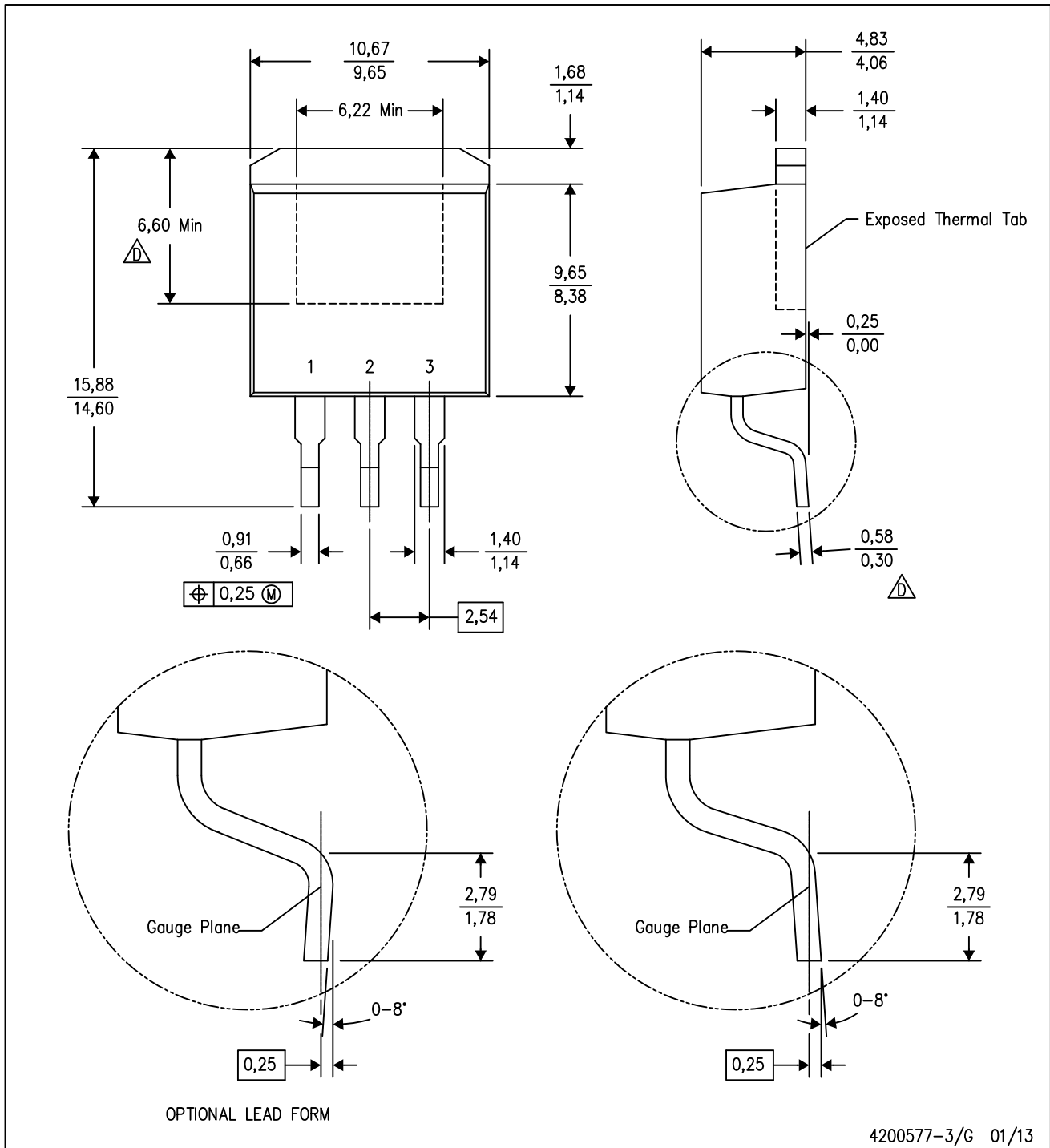

4200577-3/G 01/13

- NOTES:
- A. All linear dimensions are in millimeters.
 - B. This drawing is subject to change without notice.
 - C. Body dimensions do not include mold flash or protrusion. Mold flash or protrusion not to exceed 0.005 (0,13) per side.
- \triangle Falls within JEDEC TO-263 variation AA, except minimum lead thickness and minimum exposed pad length.

KTT (R-PSFM-G3)

PLASTIC FLANGE-MOUNT PACKAGE

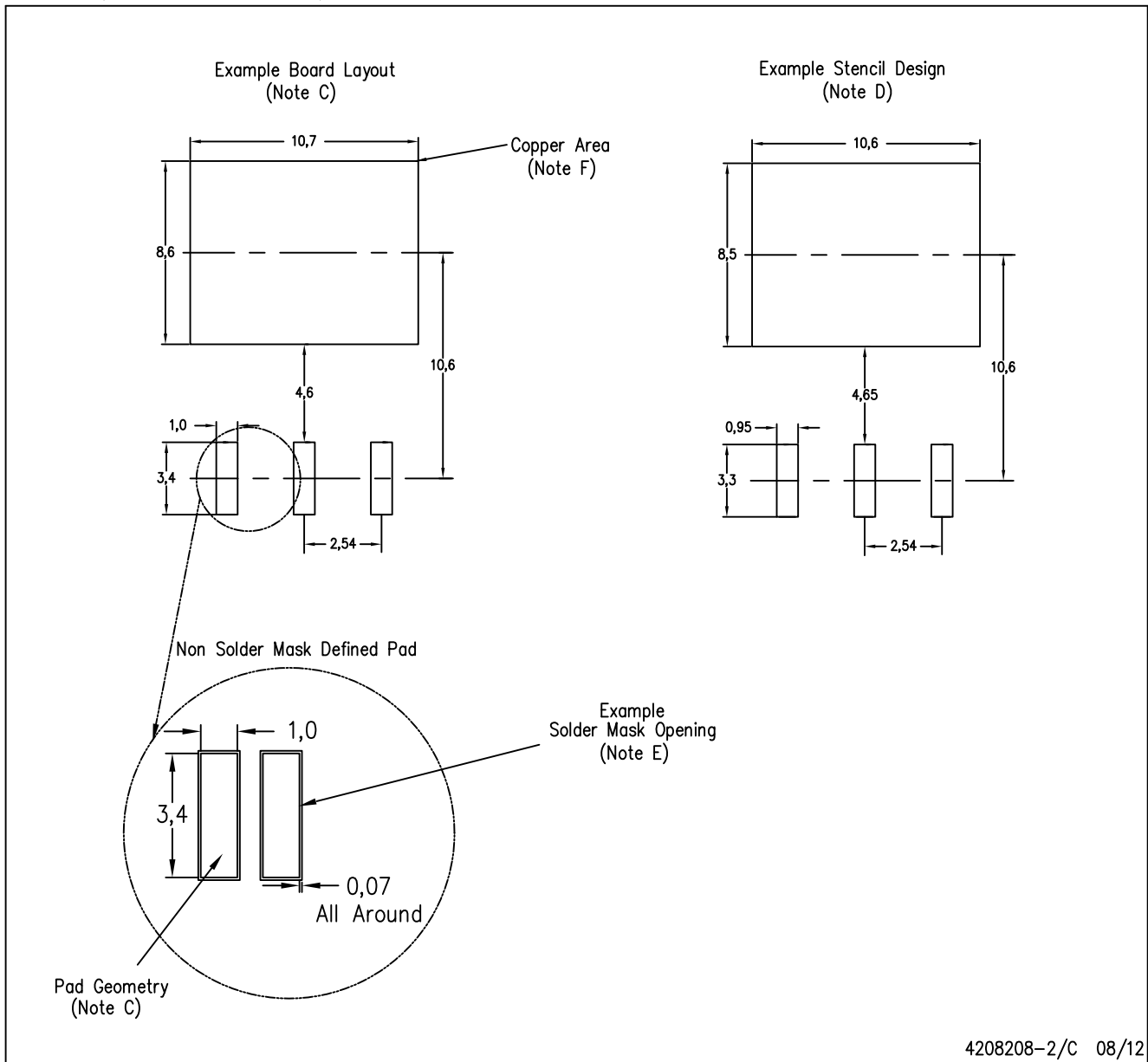

- NOTES:
- All linear dimensions are in millimeters.
 - This drawing is subject to change without notice.
 - Publication IPC-SM-782 is recommended for alternate designs.
 - Laser cutting apertures with trapezoidal walls and also rounding corners will offer better paste release. Customers should contact their board assembly site for stencil design recommendations. Refer to IPC-7525.
 - Customers should contact their board fabrication site for solder mask tolerances between and around signal pads.
 - This package is designed to be soldered to a thermal pad on the board. Refer to the Product Datasheet for specific thermal information, via requirements, and recommended thermal pad size. For thermal pad sizes larger than shown a solder mask defined pad is recommended in order to maintain the solderable pad geometry while increasing copper area.

DCY (R-PDSO-G4)

PLASTIC SMALL-OUTLINE



- NOTES: A. All linear dimensions are in millimeters (inches).
 B. This drawing is subject to change without notice.
 C. Body dimensions do not include mold flash or protrusion.
 D. Falls within JEDEC TO-261 Variation AA.

DCY (R-PDSO-G4)

PLASTIC SMALL OUTLINE



- NOTES:
- A. All linear dimensions are in millimeters.
 - B. This drawing is subject to change without notice.
 - C. Publication IPC-7351 is recommended for alternate designs.
 - D. Laser cutting apertures with trapezoidal walls and also rounding corners will offer better paste release. Customers should contact their board assembly site for stencil recommendations. Refer to IPC 7525 for stencil design considerations.

KCT0003A

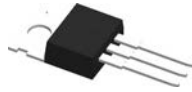

PACKAGE OUTLINE

TO-220 - 20.55 mm max height

TO-220

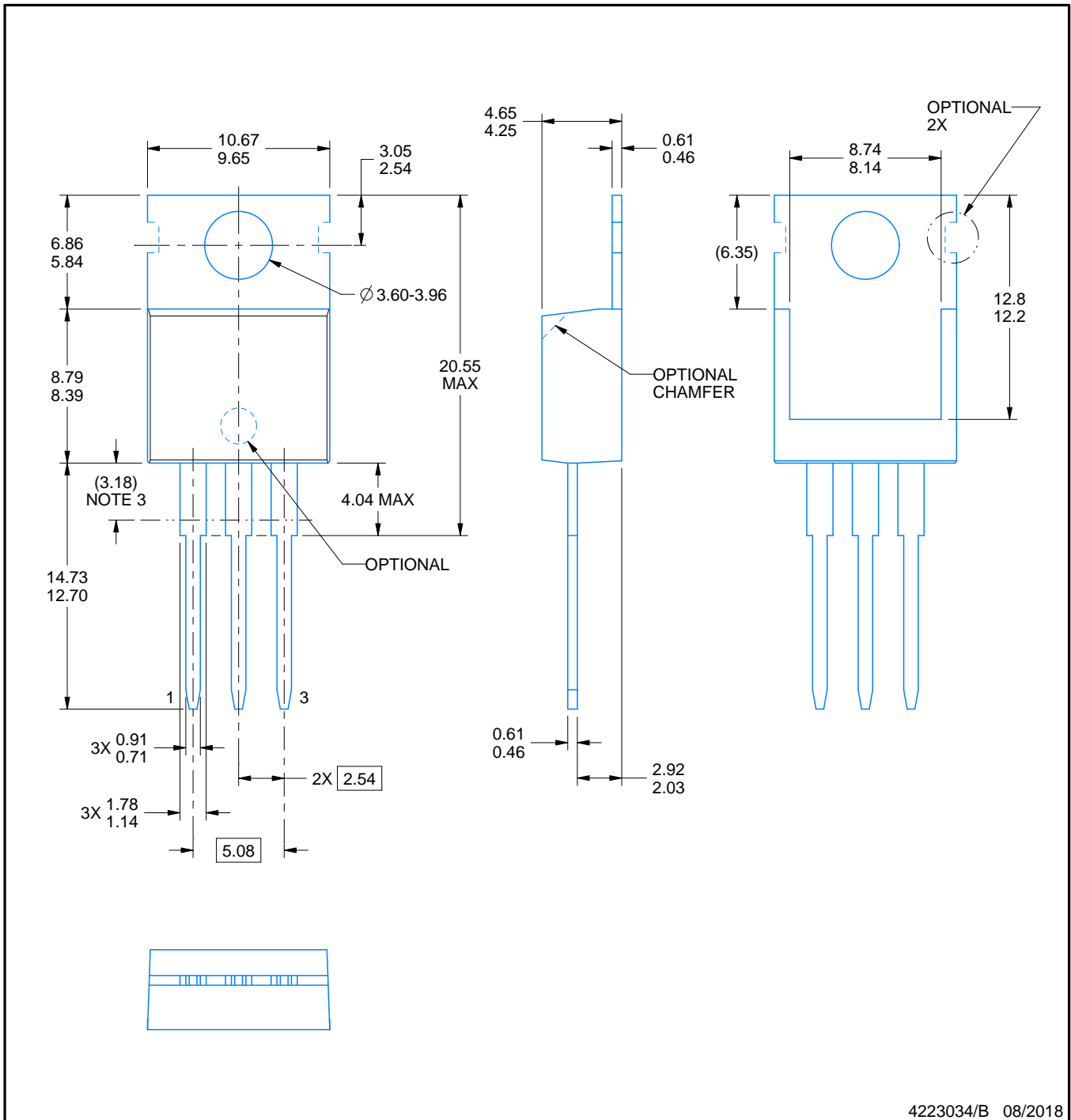

4223034/B 08/2018

NOTES:

1. Dimensions are in millimeters. Any dimension in brackets or parenthesis are for reference only. Dimensioning and tolerancing per ASME Y14.5M.
2. This drawing is subject to change without notice.
3. Lead dimensions are not controlled within this area.
4. Reference JEDEC registration TO-220.

EXAMPLE BOARD LAYOUT

KCT0003A

TO-220 - 20.55 mm max height

TO-220

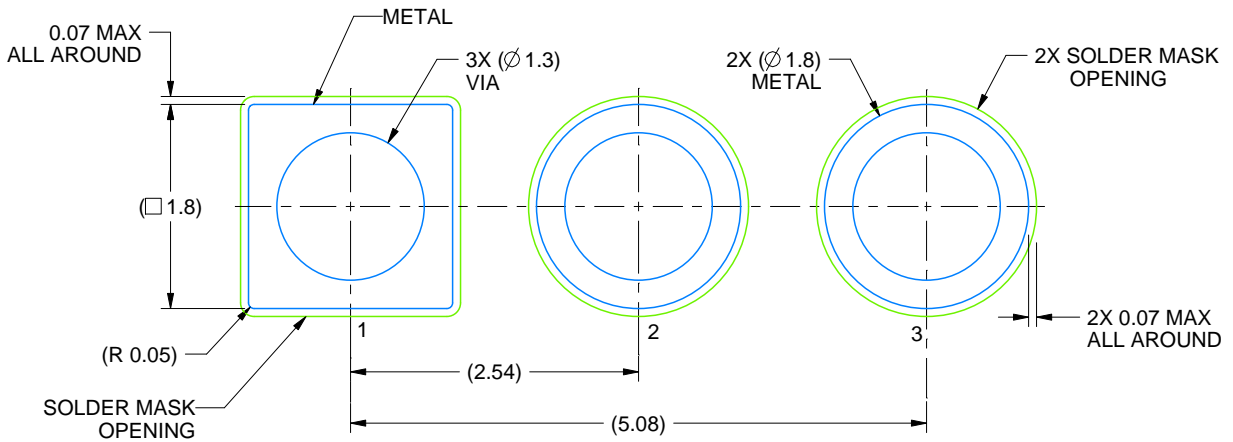

LAND PATTERN EXAMPLE
NON-SOLDER MASK DEFINED
SCALE:15X

4223034/B 08/2018

EXAMPLE BOARD LAYOUT

KCS0003B

TO-220 - 19.65 mm max height

TO-220

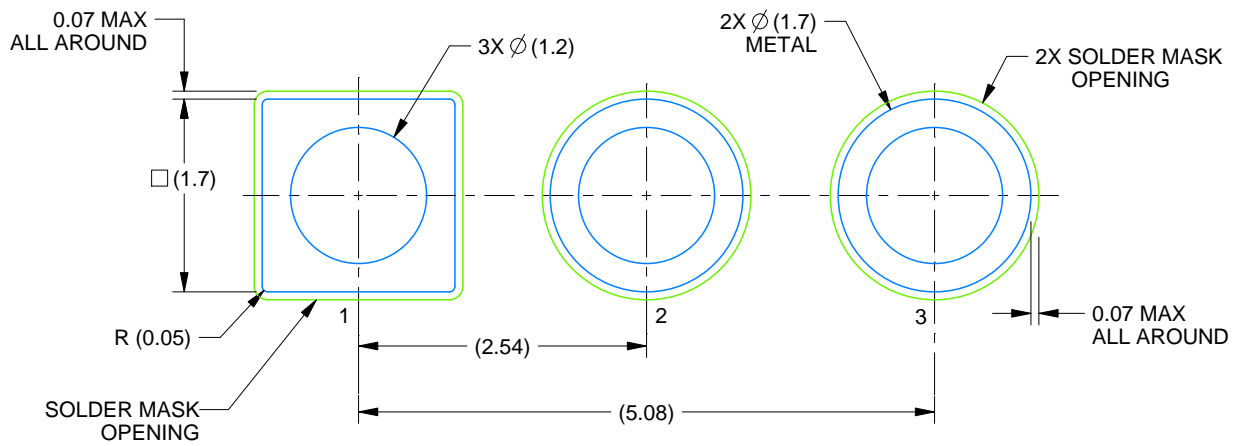

LAND PATTERN EXAMPLE
NON-SOLDER MASK DEFINED
SCALE:15X

4222214/B 08/2018

IMPORTANT NOTICE AND DISCLAIMER

TI PROVIDES TECHNICAL AND RELIABILITY DATA (INCLUDING DATASHEETS), DESIGN RESOURCES (INCLUDING REFERENCE DESIGNS), APPLICATION OR OTHER DESIGN ADVICE, WEB TOOLS, SAFETY INFORMATION, AND OTHER RESOURCES "AS IS" AND WITH ALL FAULTS, AND DISCLAIMS ALL WARRANTIES, EXPRESS AND IMPLIED, INCLUDING WITHOUT LIMITATION ANY IMPLIED WARRANTIES OF MERCHANTABILITY, FITNESS FOR A PARTICULAR PURPOSE OR NON-INFRINGEMENT OF THIRD PARTY INTELLECTUAL PROPERTY RIGHTS.

These resources are intended for skilled developers designing with TI products. You are solely responsible for (1) selecting the appropriate TI products for your application, (2) designing, validating and testing your application, and (3) ensuring your application meets applicable standards, and any other safety, security, or other requirements. These resources are subject to change without notice. TI grants you permission to use these resources only for development of an application that uses the TI products described in the resource. Other reproduction and display of these resources is prohibited. No license is granted to any other TI intellectual property right or to any third party intellectual property right. TI disclaims responsibility for, and you will fully indemnify TI and its representatives against, any claims, damages, costs, losses, and liabilities arising out of your use of these resources.

TI's products are provided subject to TI's Terms of Sale (www.ti.com/legal/termsofsale.html) or other applicable terms available either on ti.com or provided in conjunction with such TI products. TI's provision of these resources does not expand or otherwise alter TI's applicable warranties or warranty disclaimers for TI products.

Mailing Address: Texas Instruments, Post Office Box 655303, Dallas, Texas 75265
Copyright © 2019, Texas Instruments Incorporated





Looking for pricing, stock, or lifecycle information?

Click below to explore more details on WIN SOURCE:

 [View LM317DCYRG3](#) on WIN SOURCE

 [Texas Instruments](#) Information

Optimize Your Supply Chain with WIN SOURCE Solutions

-  Global Sourcing Solution
-  Obsolete Management
-  Cost Control Management
-  Shortage Management
-  Alternative Solution
-  Excess Inventory Management