

TLE4997

Programmable Linear Hall Sensor

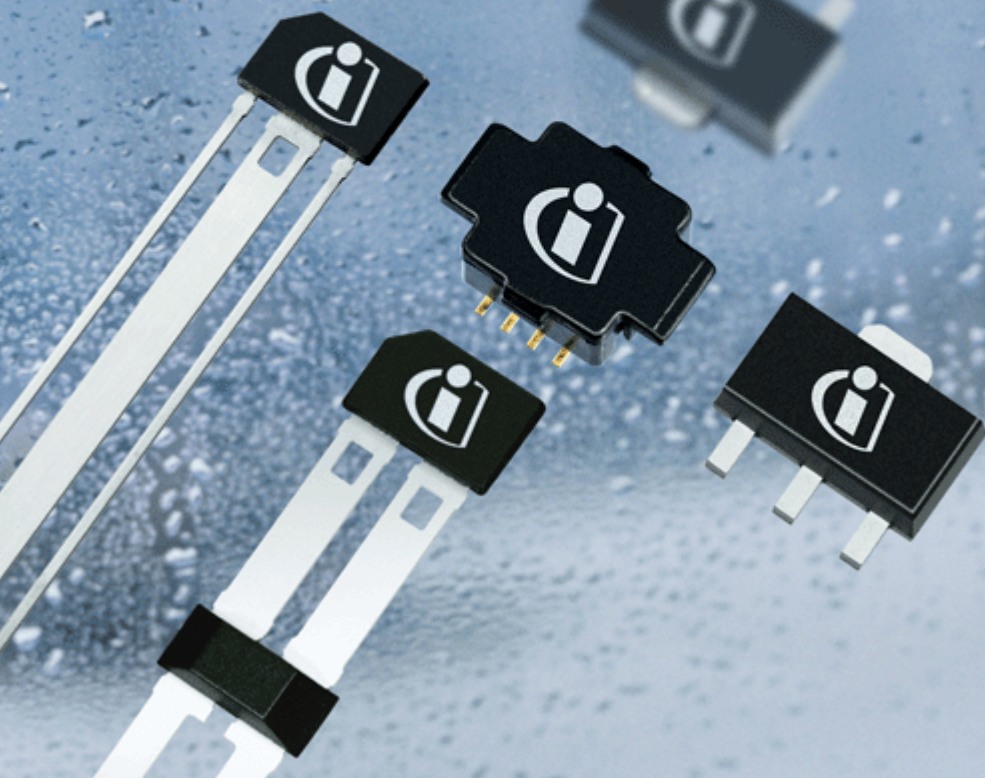

Sensors



Never stop thinking.

Edition 2018-01

**Published by Infineon Technologies AG,
Am Campeon 1-12,
85579 Neubiberg, Germany**

**© Infineon Technologies AG 2018.
All Rights Reserved.**

Attention please!

The information herein is given to describe certain components and shall not be considered as a guarantee of characteristics.

Terms of delivery and rights to technical change reserved.

We hereby disclaim any and all warranties, including but not limited to warranties of non-infringement, regarding circuits, descriptions and charts stated herein.

Information

For further information on technology, delivery terms and conditions and prices please contact your nearest Infineon Technologies Office (www.infineon.com).

Warnings

Due to technical requirements components may contain dangerous substances. For information on the types in question please contact your nearest Infineon Technologies Office.

Infineon Technologies Components may only be used in life-support devices or systems with the express written approval of Infineon Technologies, if a failure of such components can reasonably be expected to cause the failure of that life-support device or system, or to affect the safety or effectiveness of that device or system. Life support devices or systems are intended to be implanted in the human body, or to support and/or maintain and sustain and/or protect human life. If they fail, it is reasonable to assume that the health of the user or other persons may be endangered.

Table of Contents		Page
1	Overview	7
1.1	Features	7
1.2	Target Applications	8
1.3	Pin Configuration	8
2	General	9
2.1	Block Diagram	9
2.2	Functional Description	9
2.3	Principle of Operation	10
2.4	Further Notes	10
2.5	Transfer Functions	11
3	Maximum Ratings	12
4	Operating Range	13
5	Electrical and Magnetic Parameters	14
6	Signal Processing	17
6.1	Magnetic Field Ranges	18
6.2	Gain Setting	19
6.3	Offset Setting	19
6.4	DSP Input Low Pass Filter	20
6.5	DAC Input Interpolation Filter	22
6.6	Clamping	23
7	Error Detection	25
7.1	Voltages Outside the Operating Range	25
7.2	Open Circuit of Supply Lines	25
7.3	Not Correctable EEPROM Errors	26
8	Temperature Compensation	27
8.1	Parameter Calculation	28
9	Calibration	29
9.1	Calibration Data Memory	30
9.2	Programming Interface	31
9.3	Laboratory Evaluation Programmer	31
10	Application Circuit	32
11	Package Outlines	33

List of Figures**Page**

Figure 1	Pin Configuration and Hall Cell Location	8
Figure 2	Block Diagram	9
Figure 3	Examples of Operation	11
Figure 4	Ratiometry Error Band	15
Figure 5	Signal Processing Flow	17
Figure 6	DSP Input Filter (Magnitude Plot)	21
Figure 7	DAC Input Filter (Magnitude Plot)	22
Figure 8	Clamping Example	24
Figure 9	EEPROM Map	30
Figure 10	Application Circuit	32
Figure 11	PG-SSO-3-10 (Plastic Green Single Small Outline Package)	33

List of Tables		Page
Table 1	Pin Definitions and Functions	8
Table 2	Absolute Maximum Ratings	12
Table 3	Operating Range	13
Table 4	Electrical Characteristics	14
Table 5	Magnetic Characteristics	16
Table 6	Range Setting	18
Table 7	Range	18
Table 8	Gain	19
Table 9	Offset	19
Table 10	Low Pass Filter Setting	20
Table 11	Low Pass Filter	20
Table 12	Clamping	23
Table 13	Undervoltage and Overvoltage (All values with RL ³ 10k)	25
Table 14	Open Circuit (OBD Parameters)	25
Table 15	EEPROM Error Signalling	26
Table 16	Temperature Compensation	27
Table 17	Calibration Characteristics	29
Table 18	Programming Characteristics	31

1 Overview

1.1 Features

- High linear and ratiometric push-pull rail-to-rail output signal
- 20-bit Digital Signal Processing
- Digital temperature compensation
- 12-bit overall resolution
- Operates from -40°C up to 150°C
- Low drift of output signal over temperature and lifetime
- Programmable parameters stored in EEPROM with single bit error correction:
 - magnetic range and magnetic sensitivity (gain)
 - zero field voltage (offset)
 - bandwidth
 - polarity of the output slope
 - clamping option
 - temperature coefficient for all common magnets
 - memory lock
- Re-programmable until memory lock
- Single supply voltage 4.5 - 5.5 V (4 - 7 V in extended range)
- Operation between -200 mT and +200 mT within three ranges
- Slim 3-pin package (Green)
- Reverse polarity and overvoltage protection for all pins
- Output short circuit protection
- On-board diagnostics (wire breakage detection, undervoltage, overvoltage)
- Digital readout of internal temperature and magnetic field values in calibration mode.
- Individual programming and operation of multiple sensors with common power supply
- Two-point calibration of magnetic transfer function
- Precise calibration without iteration steps
- High immunity against mechanical stress, EMC, ESD

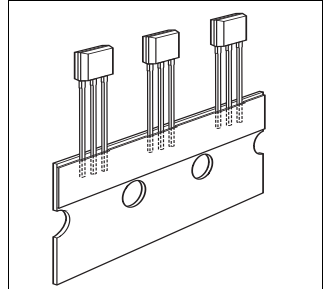

Type	Marking	Ordering Code	Package
TLE4997	4997E2	SP000235288	PG-SSO-3-10

1.2 Target Applications

- Robust replacement of potentiometers
 - No mechanical abrasion
 - Resistant to humidity, temperature, pollution and vibration
- Linear and angular position sensing in automotive applications like pedal position, suspension control, valve or throttle position, headlight levelling and steering angle
- High current sensing for battery management, motor control, and electronic fuse

1.3 Pin Configuration

Figure 1 shows the location of the Hall element in the chip and the distance between the Hall probe and the surface of the package.

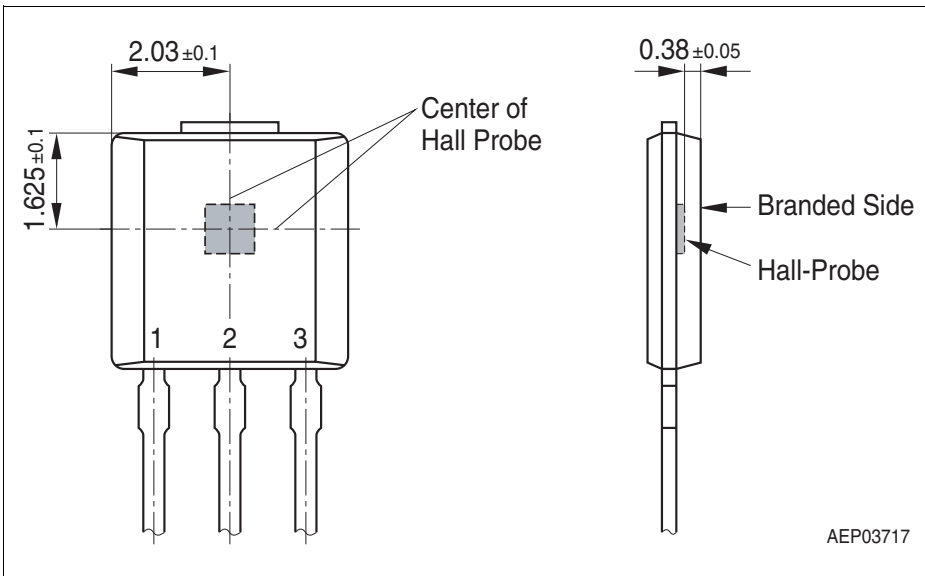

Figure 1 Pin Configuration and Hall Cell Location

Table 1 Pin Definitions and Functions

Pin No.	Symbol	Function
1	V_{DD}	Supply voltage / programming interface
2	GND	Ground
3	OUT	Output voltage / programming interface

2 General

2.1 Block Diagram

Figure 2 shows a simplified block diagram.

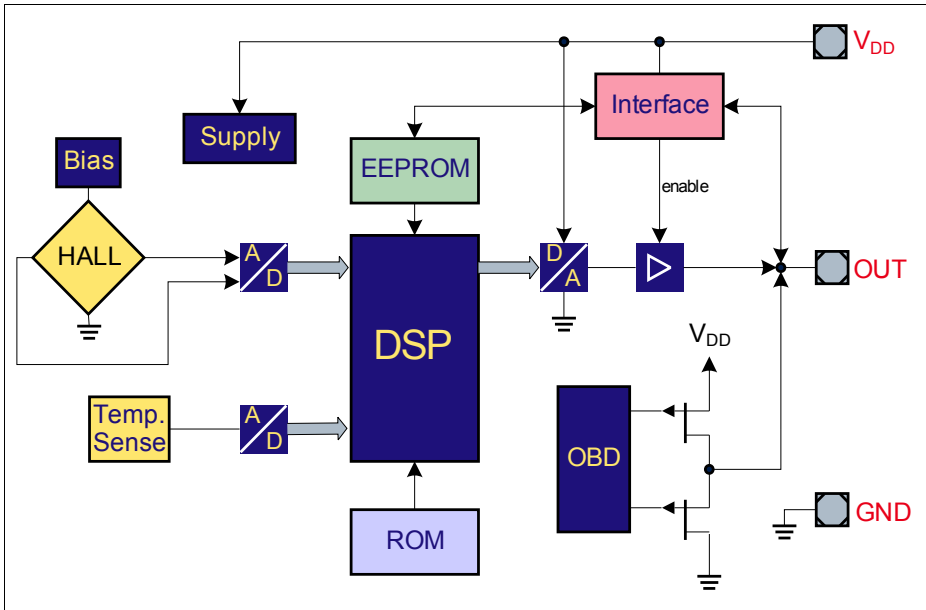

Figure 2 Block Diagram

2.2 Functional Description

The linear Hall IC has been designed specifically to meet the demands of highly accurate rotation and position detection, as well as for current measurement applications.

The sensor provides a ratiometric analog output voltage, which is ideally suited to Analog-to-Digital (A/D) conversion with the supply voltage as a reference.

The IC is produced in BiCMOS technology with high voltage capability and also provides reverse polarity protection.

Digital signal processing using a 16-bit DSP architecture and digital temperature compensation guarantees excellent stability over a long period of time.

The minimum overall resolution is 12 bits. Nevertheless, some internal stages work with resolutions up to 20 bits.

2.3 Principle of Operation

- A magnetic flux is measured by a Hall-effect cell.
- The output signal from the Hall-effect cell is converted from Analog to Digital signals.
- The chopped Hall-effect cell and continuous-time A to D conversion provide very low and stable magnetic offset.
- A programmable Low-Pass filter reduces the noise.
- The temperature is measured and A to D converted.
- Temperature compensation is processed digitally using a second order function.
- Digital processing of output voltage is based on zero field and sensitivity value.
- The output voltage range can be clamped by digital limiters.
- The final output value is D to A converted.
- The output voltage is proportional to the supply voltage (ratiometric DAC).
- An On-Board-Diagnostics (OBD) circuit connects the output to V_{DD} or GND in case of errors.

2.4 Further Notes

Product qualification is based on "AEC Q100" (Automotive Electronics Council - Stress test qualification for integrated circuits).

2.5 Transfer Functions

The examples in **Figure 3** show how easily different magnetic field ranges can be mapped to the output voltage.

- Polarity Mode:
 - **Unipolar:** Only North- or South-oriented magnetic fields are measured.
 - **Bipolar:** Magnetic fields can be measured in both orientations. The limit points must not be symmetric to the zero field point.
- Inversion: The gain values can be set positive or negative.

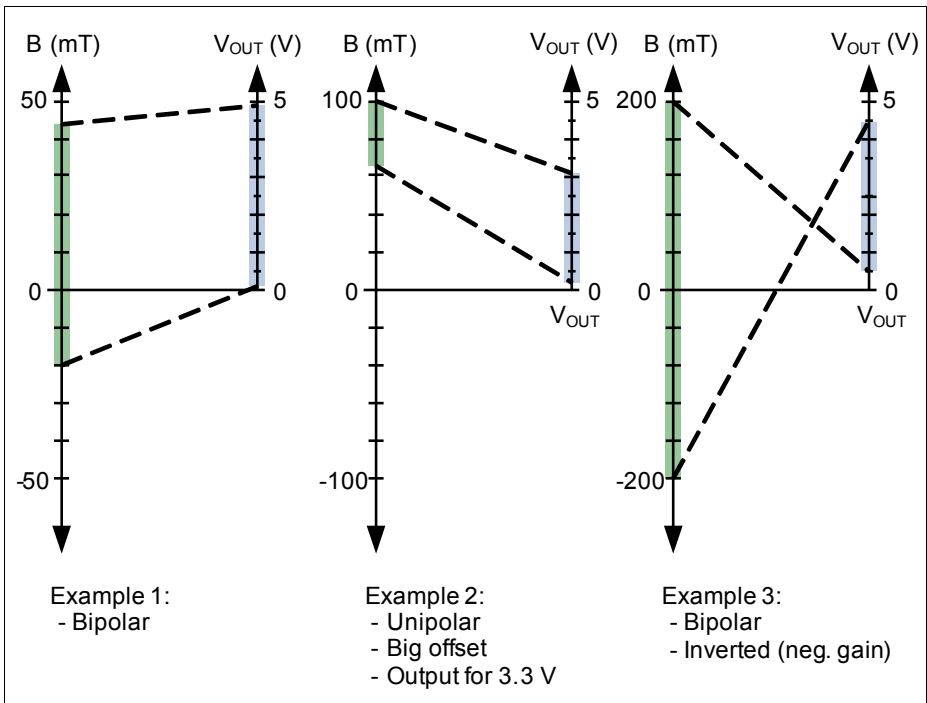

Figure 3 Examples of Operation

Note: Due to the ratiometry, voltage drops at the V_{DD} line are imaged in the output signal.

3 Maximum Ratings

Table 2 Absolute Maximum Ratings

Parameter	Symbol	Limit Values		Unit	Notes
		min.	max.		
Storage temperature	T_{ST}	-40	150	°C	
Junction temperature	T_J	-40	170	°C	For 96h ¹⁾
Voltage on V_{DD} pins with respect to ground (V_{SS})	V_{DD}	-20 ²⁾	20 ³⁾	V	⁴⁾ $R_{THja} \leq 150$ K/W
Supply current @ overvoltage	I_{DDov}	-	52	mA	
Supply current @ reverse voltage	I_{DDrev}	- 75	-	mA	
Voltage on output pin with respect to ground (V_{SS})	V_{OUTov}	-16 ⁵⁾	16 ³⁾	V	$R_{THja} \leq 150$ K/W V_{out} may be $> V_{DD}$
Magnetic field	B_{MAX}	-	unlimited	T	
ESD protection	V_{ESD}	-	4.0	kV	According HBM JESD22-A114-B ⁶⁾

¹⁾ For limited time only. Depends on customer temperature lifetime cycles. Please ask for support by Infineon.

²⁾ max 24 h @ $-50^{\circ}\text{C} \leq T_a < 30^{\circ}\text{C}$
max 10 min. @ $30^{\circ}\text{C} \leq T_a < 80^{\circ}\text{C}$
max 30 sec. @ $80^{\circ}\text{C} \leq T_a < 125^{\circ}\text{C}$
max 15 sec. @ $125^{\circ}\text{C} \leq T_a \leq 150^{\circ}\text{C}$.

³⁾ max. 24 h @ $T_J < 80^{\circ}\text{C}$.

⁴⁾ Guaranteed by laboratory characterization, tested at $\pm 18\text{V}$.

⁵⁾ Max. 1 ms @ $T_J < 30^{\circ}\text{C}$; -8.5 V for 100 h @ $T_J < 80^{\circ}\text{C}$.

⁶⁾ 100 pF and 1.5 k Ω

Note: Stresses above those listed under “Absolute Maximum Ratings” may cause permanent damage to the device. This is a stress rating only and functional operation of the device at these or any other conditions above those indicated in the operational sections of this specification is not implied. Furthermore, only single error cases are assumed. More than one stress/error case may also damage the device.

Exposure to absolute maximum rating conditions for extended periods may affect device reliability. During absolute maximum rating overload conditions ($V_{IN} > V_{DD}$ or $V_{IN} < V_{SS}$) the voltage on V_{DD} pins with respect to ground (V_{SS}) must not exceed the values defined by the absolute maximum ratings.

4 Operating Range

The following operating conditions must not be exceeded in order to ensure correct operation of the . All parameters specified in the following sections of this document refer to these operating conditions, unless otherwise indicated.

Table 3 Operating Range

Parameter	Symbol	Limit Values		Unit	Notes
		min.	max.		
Supply voltage	V_{DD}	4.5	5.5	V	
		4	7	V	Extended range ¹⁾
Output current	I_{OUT}	-1	1	mA	²⁾
Load resistance	R_L	10	-	k Ω	Pull-down to GND
		10	-		Pull-up to V_{DD}
Load capacitance	C_L	0	210	nF	
Junction temperature ³⁾	T_J	-40	125 150	$^{\circ}\text{C}$	For 5000h For 1000h ⁴⁾ ⁵⁾
Useful lifetime	t_{Live}	-	16	years	

¹⁾ For reduced output accuracy.

²⁾ For V_{OUT} within the range of 5% ... 95% of V_{DD} .

³⁾ $R_{THja} \leq 150$ K/W.

⁴⁾ For reduced magnetic accuracy.

⁵⁾ Not additive.

Note: Keeping signal levels within the limits specified in this table ensures operation without overload conditions.

5 Electrical and Magnetic Parameters

Table 4 Electrical Characteristics

Parameter	Symbol	Limit Values			Unit	Notes
		min.	typ.	max.		
Output voltage range	V_{OUT}	5 6	-	95 94	% of V_{DD}	For $T_A \leq 120^\circ\text{C}$ For $T_A > 120^\circ\text{C}$
Supply current	I_{DD}	3	7.5	10	mA	¹⁾
Output current @ OUT shorted to supply lines	I_{OUTsh}	-30	-	30	mA	For operating supply voltage range only
Zero field voltage	V_{ZERO}	-100	-	100	%	Of V_{DD} ²⁾
Zero field voltage drift	ΔV_{ZERO}	-10	-	10	mV	In lifetime ³⁾
		-10	-	10	mV	Error band ov. temp. ³⁾
Ratiometry error	E_{RAT}	-0.25	-	+0.25	%	Of V_{DD} ⁴⁾⁵⁾
Thermal resistance	R_{thJA}	-	-	219	K/W	Junction to air
	R_{thJC}	-	-	47	K/W	Junction to case
Power on time	t_{Pon}	-	-	1 10	ms	$\Delta V_{OUT} \leq \pm 5\%$ of V_{DD} $\Delta V_{OUT} \leq \pm 1\%$ of V_{DD}
Power On Reset level	V_{DDpon}	2	-	4	V	
Output DAC quantization	ΔV_{OUT}	1.22			mV	@ $V_{DD} = 5\text{ V}$
Output DAC resolution	-	12			bit	
Output DAC bandwidth	f_{DAC}	-	3.2	-	kHz	Interpolation filter ⁶⁾
Output noise	V_{noise}	-	-	4.68	mV _{pp}	5% exceeded ⁷⁾⁸⁾
Differential non-linearity	DNL	-1	-	1	LSB	Of output DAC
Signal delay	t_{DS}	-	-	250	μs	@ 100 Hz ⁹⁾

¹⁾ Also in extended V_{DD} range. For V_{OUT} within the range of 5%... 95% of V_{DD} , $I_{OUT} = 0\text{ mA}$.

²⁾ Programmable in steps of 1.22 mV (@ $V_{DD} = 5\text{ V}$).

³⁾ For Sensitivity $S \leq 25\text{ mV/mT}$. For higher sensitivities the magnetic offset drift is dominant. This means that for the precalibrated (typical) 60mV/mT sensitivity the typical output drift might be given due to the allowed magnetic offset tolerance up to $\pm 0.4\text{ mT} \times 60\text{ mV/mT} = \pm 24\text{ mV}$.

⁴⁾ For $4.5\text{ V} \leq V_{DD} \leq 5.5\text{ V}$ and within nominal V_{OUT} range; see **"Ratiometry" on Page 15** for details on E_{RAT} .

⁵⁾ For the maximum error in the extended voltage range, see **"Ratiometry" on Page 15**.

⁶⁾ More information, see **"DAC Input Interpolation Filter" on Page 22**.

⁷⁾ 100 mT range, sensitivity 60 mV/mT, LP-filter 244 Hz, 160 Hz external RC low pass filter as application circuit.

⁸⁾ '5% exceeded' means that 5 of 100 continuously measured V_{OUT} samples are out of limit.

⁹⁾ A sinusoidal magnetic field is applied, V_{OUT} shows amplitude of 20% of V_{DD} , no LP filter is selected.

Ratiometry

The linear Hall sensor works like a potentiometer. The output voltage is proportional to the supply voltage. The division factor depends on the magnetic field strength. This behavior is called “ratiometric”.

The supply voltage V_{DD} should be used as the reference for the A/D Converter of the microcontroller. In this case, variations of V_{DD} are compensated.

The ratiometry error is defined as follows:

$$E_{RAT} = \left(\frac{V_{OUT}(V_{DD})}{V_{DD}} - \frac{V_{OUT}(5V)}{5V} \right) \times 100 \%$$

The ratiometry error band displays as a “Butterfly Curve”.

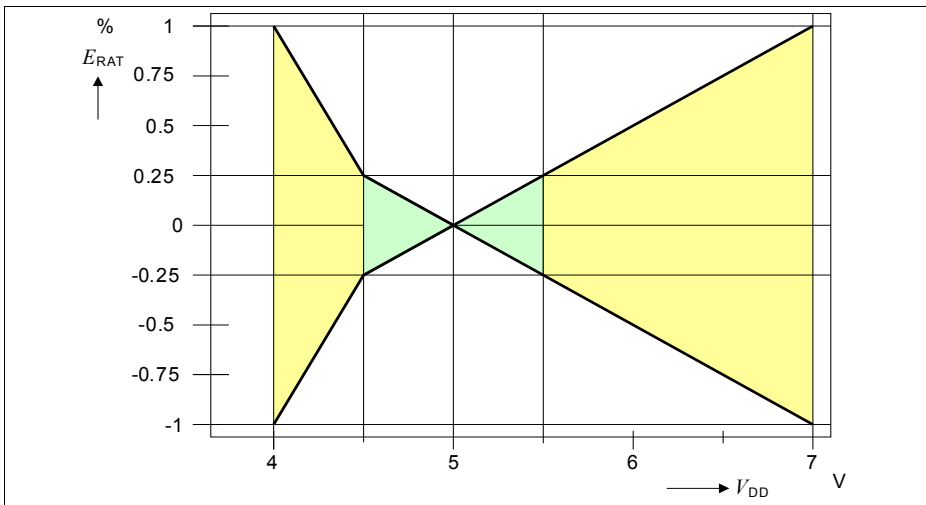

Figure 4 Ratiometry Error Band

Note: Take care of possible voltage drops on the V_{DD} and V_{OUT} line degrading the result. Ideally, both values are acquired and their ratio is calculated to gain the highest accuracy. This method should be used especially during calibration.

Electrical and Magnetic Parameters
Calculation of the Junction Temperature

The total power dissipation P_{TOT} of the chip increases its temperature above the ambient temperature. The power multiplied with the total thermal resistance R_{thJA} (Junction to Ambient) leads to the final junction temperature. R_{thJA} is the sum of the addition of the values of the two components *Junction to Case* and *Case to Ambient*.

$$R_{thJA} = R_{thJC} + R_{thCA}$$

$$T_J = T_A + \Delta T$$

$$\Delta T = R_{thJA} \times P_{TOT} = R_{thJA} \times (V_{DD} \times I_{DD} + V_{OUT} \times I_{OUT}) \quad I_{DD}, I_{OUT} > 0, \text{ if direction is into IC}$$

Example (assuming no noticeable load on V_{out}):

- $V_{DD} = 5 \text{ V}$
- $I_{DD} = 10 \text{ mA}$
- $\Delta T = 219 \text{ [K/W]} \times (5 \text{ [V]} \times 0.01 \text{ [A]} + 0 \text{ [VA]}) = 11 \text{ K}$

For moulded sensors, the calculation with R_{thJC} is more adequate.

Magnetic Parameters
Table 5 Magnetic Characteristics

Parameter	Symbol	Limit Values			Unit	Notes
		min.	typ.	max.		
Sensitivity	S	± 12.5	-	± 300	mV/mT	1)
Sensitivity error band over temperature	S_E	-4	-	4	%	2)
Magnetic field range	MFR	± 50	± 100 ³⁾	± 200	mT	Programmable ⁴⁾
Integral nonlinearity	INL	-15	-	15	mV	$= \pm 0.3\%$ of V_{DD} ⁵⁾
Magnetic offset	B_{OS}	-400	-	400	μT	6) 7) 8)
Magnetic offset drift	ΔB_{OS}	- 5	-	5	$\mu\text{T} / ^\circ\text{C}$	Error band ⁷⁾

1) Programmable in steps of 0.024%, @ $V_{DD} = 5 \text{ V}$ and $T_J = 25^\circ\text{C}$

2) Residual sensitivity error band over temperature when using minimum 2 temperatures.

3) This range is also used for temperature and offset pre-calibration of the IC.

4) Depending on the Offset and Gain settings, the output may saturate at lower fields.

5) $INL = V_{out} - V_{out,lse}$ with $V_{out,lse}$ = least square error fit of V_{out} . Valid in the range $(5\% \text{ of } V_{DD}) < V_{OUT} < (95\% \text{ of } V_{DD})$ for $T_J \leq 120^\circ\text{C}$ and $(6\% \text{ of } V_{DD}) < V_{OUT} < (94\% \text{ of } V_{DD})$ for $120^\circ\text{C} < T_J \leq 150^\circ\text{C}$

6) In operating temperature range and over lifetime.

7) For Sensitivity $S > 25 \text{ mV} / \text{mT}$. For lower sensitivities, the zero field voltage drift is dominant.

8) Measured at $\pm 100 \text{ mT}$ range.

6 Signal Processing

The flow diagram in **Figure 5** shows the data processing algorithm.

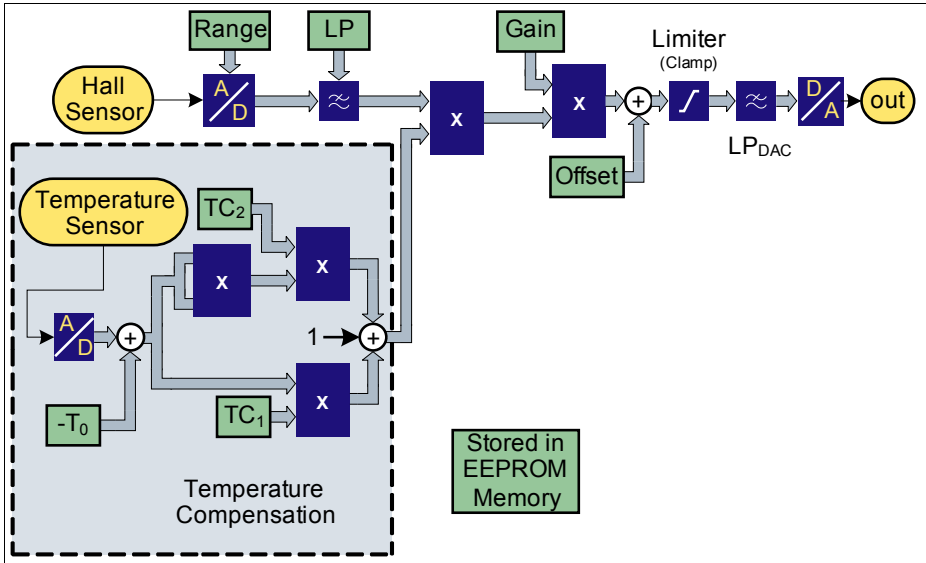

Figure 5 Signal Processing Flow

Magnetic Field Path

- The analog output signal of the chopped Hall cell is converted in the continuous-time A/D Converter. The range of the chopped A/D Converter can be set in several steps (see **Table 6**). This assures a suitable level for the A/D Converter.
- After the A/D conversion, a digital low pass filter reduces the bandwidth (**Table 10**).
- A multiplier amplifies the value according to the gain setting (see **Table 8**) plus temperature compensation.
- The offset value is added (see **Table 9**).
- A limiter reduces the resulting signal to 12 bits and feeds the D/A converter.

Temperature Compensation

(Details are listed in **Chapter 8**)

- The output signal of the temperature cell is also A/D converted.
- The temperature is normalized by subtraction of the T_0 value (zero point of the quadratic function).
- The linear path is multiplied with the TC_1 value.

- In the quadratic path, the difference temperature is squared and multiplied with the TC_2 value.
- Both path outputs are added together and multiplied with the gain value from the EEPROM.

6.1 Magnetic Field Ranges

The working range of the magnetic field defines the input range of the A/D Converter. It is always symmetric to the zero field point. Any two points in the magnetic range can be selected to be the end points of the output curve. The output voltage represents the range between the two points.

In the case of fields higher than the range values, the output signal may be distorted.

The range must be set before the calibration of offset and gain.

Table 6 Range Setting

Range	Range in mT	Parameter R
Low	± 50	3
Mid	± 100	1
High	± 200	0

Table 7 Range

Parameter	Symbol	Limit Values		Unit	Notes
		min.	max.		
Register size	<i>R</i>	2		bit	1)

1) Ranges do not have a guaranteed absolute accuracy. The temperature pre-calibration is performed in the mid range (100 mT).

6.2 Gain Setting

The sensitivity is defined by the range and the gain setting. The output of the A/D Converter is multiplied with the gain value.

Table 8 Gain

Parameter	Symbol	Limit Values		Unit	Notes
		min.	max.		
Register size	G	15		bit	Unsigned integer value
Gain range	$Gain$	- 4.0	3.9998	-	1)2)
Gain quantization steps	$\Delta Gain$	244.14		ppm	Corresponds to 1/4096

1) For gain values between - 0.5 and + 0.5, the numeric accuracy decreases.

To obtain a flatter output curve, it is recommended to select a higher range setting.

2) A gain value of +1.0 corresponds to a typical 40 mV/mT sensitivity (100 mT range, not guaranteed). Infineon pre-calibrates the samples to 60mV/mT (100mT range) in the final test, but does not guarantee the accuracy of this calibration. It is crucial to do a final calibration of each IC within the application using the Gain/ V_{OS} value.

The gain value can be calculated by

$$Gain = \frac{(G - 16384)}{4096}$$

6.3 Offset Setting

The offset voltage corresponds to an output voltage with zero field at the sensor.

Table 9 Offset

Parameter	Symbol	Limit Values		Unit	Notes
		min.	max.		
Register size	OS	15		bit	Unsigned integer value
Offset range	V_{OS}	-400	399	% V_{DD}	1)
Offset quantization steps	ΔV_{OS}	1.22		mV	@ $V_{DD} = 5 V$ generally $V_{DD} / 4095$

1) Infineon pre-calibrates the samples at zero field to 50% of V_{DD} (100mT range) in the final test, but does not guarantee the accuracy of this calibration. It is crucial to do a final calibration of each IC within the application using the Gain/ V_{OS} value.

The offset value can be calculated by:

$$V_{OS} = \frac{(OS - 16384)}{4096} \times V_{DD}$$

6.4 DSP Input Low Pass Filter

A digital Low Pass Filter is placed between the Hall A/D Converter and the DSP to reduce the noise level. The Low Pass filter has a constant DC amplification of 0 dB (this is exactly a gain of 1), which means that its setting has no influence on the internal Hall A/D Converter value.

The bandwidth can be set in 8 steps.

Table 10 Low Pass Filter Setting

Parameter LP	Cutoff frequency in Hz (at 3dB attenuation) ¹⁾
0	78
1	244
2	421
3	615
4	826
5	1060
6	1320
7	off ²⁾

¹⁾ As this is a digital filter running with an RC-based oscillator, the cutoff frequency may vary within $\pm 25\%$.

²⁾ The output low pass-interpolation filter behavior remains as main component in the signal path.

Table 11 Low Pass Filter

Parameter	Symbol	Limit Values		Unit	Notes
		min.	max.		
Register size	LP	3		bit	
Corner frequency variation	Δf	- 25	+ 25	%	

Note: In Low Pass filter setting 7 (filter off), the output noise increases. Because of higher DSP load, the current consumption also rises slightly.

Figure 6 shows the characteristic of the filter as a magnitude plot (the highest setting is marked). The “off” position would be a flat 0 dB line. In this case, the output decimation filter limits the bandwidth of the sensor. The update rate after the Low Pass filter is 16 kHz.

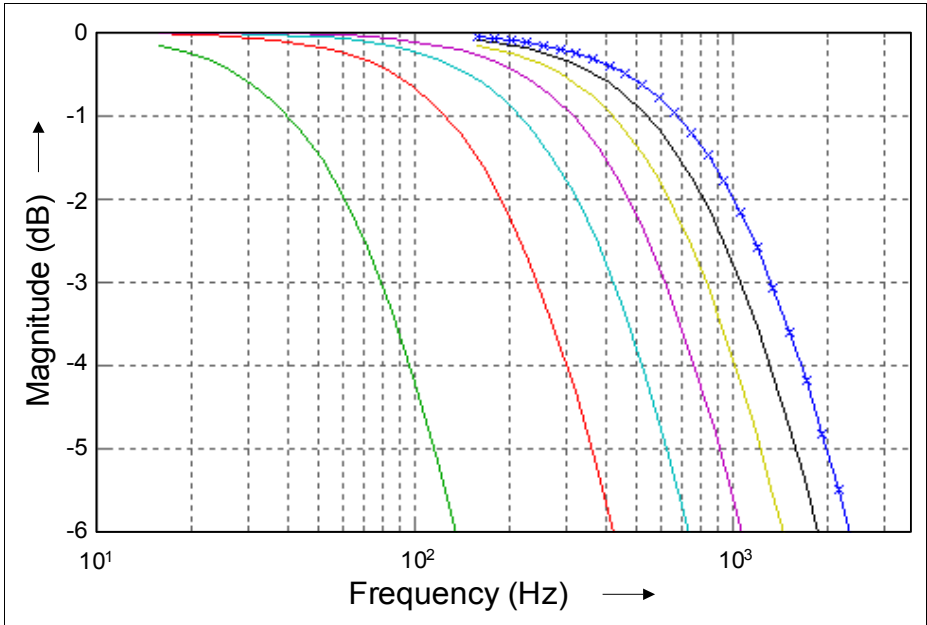

Figure 6 DSP Input Filter (Magnitude Plot)

6.5 DAC Input Interpolation Filter

An interpolation filter is placed between the DSP and the output DAC. It cannot be switched off. This filter limits the frequency behavior of the complete system if the DSP input filter is disabled. The update rate after the interpolation filter is 256 kHz.

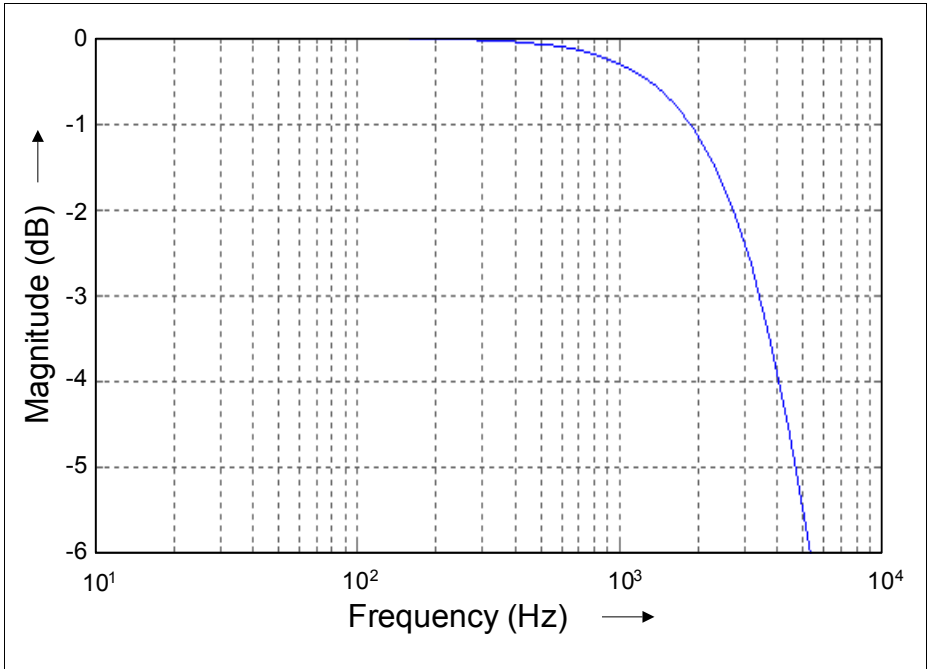

Figure 7 DAC Input Filter (Magnitude Plot)

Note: As this is a digital filter running with an RC-based oscillator, the cutoff frequency may vary within ±25%.

6.6 Clamping

The clamping function is useful for splitting the output voltage into the operating range and error ranges. If the magnetic field is outside the selected measurement range, the output voltage V_{out} is limited to the clamping values.

Table 12 Clamping

Parameter	Symbol	Limit Values		Unit	Notes
		min.	max.		
Register size	CL, CH	2 x 12		bit	
Clamping voltage low	V_{CLL}	0	99.98	% V_{DD}	1)
Clamping voltage high	V_{CLH}	0	99.98	% V_{DD}	1)
Clamping quantization steps	ΔV_{CLQ}	1.22		mV	@ $V_{DD} = 5\text{ V}$
Clamping voltage drift	ΔV_{CL}	-15	15	mV	in lifetime ²⁾
		-15	15		over temperature ²⁾

1) If clamping is set, it must be within the allowed output voltage range to be effective.

2) Valid in the range $(5\% \text{ of } V_{DD}) < V_{OUT} < (95\% \text{ of } V_{DD})$ for $T_J \leq 120^\circ\text{C}$
and $(6\% \text{ of } V_{DD}) < V_{OUT} < (94\% \text{ of } V_{DD})$ for $120^\circ\text{C} < T_J \leq 150^\circ\text{C}$

The clamping values are calculated by:

Clamping low voltage:

$$V_{CLL} = \frac{CL}{4096} \times V_{DD}$$

Clamping high voltage:

$$V_{CLH} = \frac{CH}{4096} \times V_{DD}$$

Note: For an exact setup, the register value may be re-adjusted due to the actual output voltage in the clamping condition. The output voltage range itself has electrical limits. See the [Electrical Characteristics](#) of V_{out} .

Signal Processing

Figure 8 shows an example in which the magnetic field range between B_{min} and B_{max} is mapped to voltages between 0.8 V and 4.2 V.

If it is not necessary to signal errors, the maximum output voltage range between 0.3 V and 4.7 V can be used.

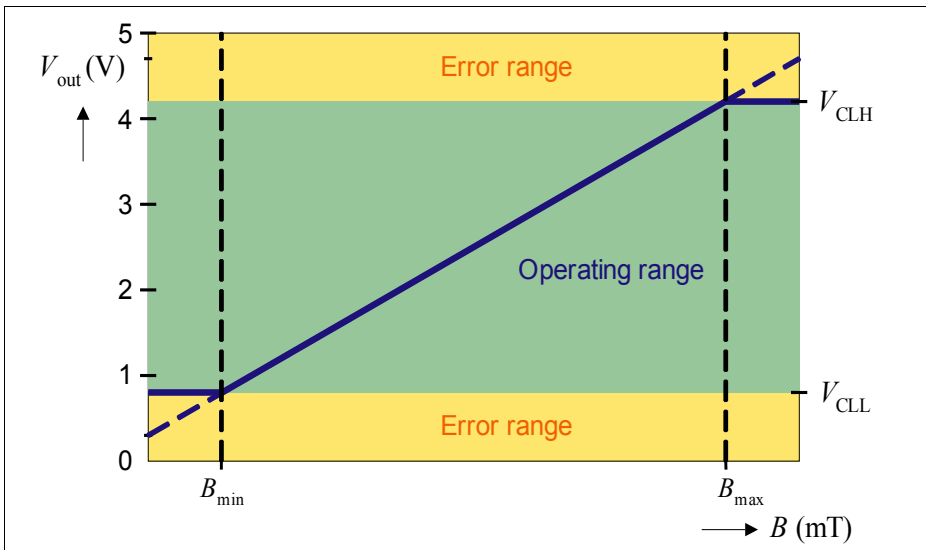

Figure 8 Clamping Example

Note: The high value must be above the low value.

If V_{CLL} is set to a higher value than V_{CLH} , the V_{CLH} value is dominating. This would lead to a constant output voltage independent of the magnetic field strength.

7 Error Detection

Different error cases can be detected by the On-Board-Diagnostics (OBD) and reported to the microcontroller. The OBD is useful only when the clamping function is enabled. It is important to set the clamping threshold values inside the error voltage values shown in [Table 13](#) and [Table 14](#) to ensure that it is possible to distinguish between correct output voltages and error signals.

7.1 Voltages Outside the Operating Range

The output signals error conditions, if V_{DD} lies

- inside the ratings specified in [Table 2 "Absolute Maximum Ratings" on Page 12](#)
- outside the range specified in [Table 3 "Operating Range" on Page 13](#).

Table 13 Undervoltage and Overvoltage (All values with $R_L \geq 10k$)

Parameter	Symbol	Limit Values		Unit	Notes
		min.	max.		
Undervoltage threshold	V_{DDuv}	3	4	V	
Overvoltage threshold	V_{DDov}	7	8.3	V	
Output voltage @ undervoltage	V_{OUTuv}	$0.95 \times V_{DD}$	-	V	$3V \leq V_{DD} \leq V_{DDuv}$
Output voltage @ overvoltage	V_{OUTov}	$0.97 \times V_{DD}$	-	V	$V_{DDov} < V_{DD} \leq 16V$
Supply current ¹⁾	I_{DDuv}	-	10	mA	@ undervoltage

¹⁾ For overvoltage and reverse voltage, see [Table 2 "Absolute Maximum Ratings" on Page 12](#).

7.2 Open Circuit of Supply Lines

In the case of interrupted supply lines, the data acquisition device can alert the user. If two sensors are placed in parallel, the output of the remaining working sensor may be still used for an emergency operation.

Table 14 Open Circuit (OBD Parameters) ¹⁾

Parameter	Symbol	Limit Values		Unit	Notes
		min.	max.		
Output voltage @ open V_{DD} line	V_{OUT}	0	0.18 0.2	V	$T_J \leq 120^\circ C$ $120^\circ C < T_J \leq 150^\circ C$
Output voltage @ open GND line	V_{OUT}	4.82 4.8	5	V	$T_J \leq 120^\circ C$ $120^\circ C < T_J \leq 150^\circ C$

¹⁾ With $V_{DD} = 5V$ and $R_L \geq 10k\Omega$ pull-down or $R_L \geq 20k\Omega$ pull-up.

7.3 Not Correctable EEPROM Errors

The parity method is able to correct one single bit in one EEPROM line. One other single bit error in another line can also be detected. As this situation is not correctable, this status is signalled at the output pin by clamping the output value to V_{DD} .

Table 15 EEPROM Error Signalling

Parameter	Symbol	Limit Values		Unit	Notes
		min.	max.		
Output voltage @ EEPROM error	V_{OUT}	$0.97 \times V_{DD}$	V_{DD}	V	

8 Temperature Compensation

The magnetic field strength of a magnet depends on the temperature. This material constant is specific to different magnet types. Therefore, the offers a second order temperature compensation polynomial, by which the Hall signal output is multiplied in the DSP. There are three parameters for the compensation:

- Reference temperature T_0
- A linear part (1st order) TC_1
- A quadratic part (2nd order) TC_2

The following formula describes the sensitivity dependent on the temperature in relation to the sensitivity at the reference temperature T_0 :

$$S_{TC}(T) = 1 + TC_1 \times (T - T_0) + TC_2 \times (T - T_0)^2$$

For more information, see also the signal processing flow in [Figure 5](#).

The full temperature compensation of the complete system is done in two steps:

1. Pre-calibration in the Infineon final test.

The parameters TC_1 , TC_2 , T_0 are set to maximally flat temperature characteristics regarding the Hall probe and internal analog processing parts.

2. Overall System calibration.

The typical coefficients TC_1 , TC_2 , T_0 of the magnetic circuitry are programmed. This can be done deterministically, as the algorithm of the DSP is fully reproducible. The final settings of the TC_1 , TC_2 , T_0 values are relative to the pre-calibrated values.

Table 16 Temperature Compensation

Parameter	Symbol	Limit Values		Unit	Notes
		min.	max.		
Register size TC_1	TL	-	9	bit	Unsigned integer values
1 st order coefficient TC_1	TC_1	-1000	2500	ppm/ °C	¹⁾
Quantization steps of TC_1	ΔTC_1	15.26		ppm/ °C	
Register size TC_2	TQ	-	8	bit	Unsigned integer values
2 nd order coefficient TC_2	TC_2	- 4	4	ppm/ °C ²	²⁾
Quantization steps of TC_2	ΔTC_2	0.119		ppm/ °C ²	
Register size T_0	TR	-	3	bit	Unsigned integer values
Reference temperature	T_0	- 48	64	°C	
Quantization steps of T_0	ΔT_0	16		°C	³⁾

¹⁾ Relative range to Infineon TC_1 temperature pre-calibration, the maximum adjustable range is limited by the register-size and depends on specific pre-calibrated TL setting, full adjustable range: -2441 to +5355 ppm/°C

Temperature Compensation

- 2) Relative range to Infineon TC2 temperature pre-calibration, the maximum adjustable range is limited by the register-size and depends on specific pre-calibrated TQ setting, full adjustable range: -15 to +15 ppm/°C²
- 3) A quantization step of 1°C is handled by algorithm (See Application Note).

8.1 Parameter Calculation

The parameters TC₁, TC₂ and T₀ may be calculated by:

$$TC_1 = \frac{TL - 160}{65536} \times 1000000$$

$$TC_2 = \frac{TQ - 128}{8388608} \times 1000000$$

$$T_0 = 16TR - 48$$

Now the output V_{OUT} for a given field B_{IN} at a specific temperature can be roughly calculated by:

$$V_{OUT} = \left(\frac{B_{IN}}{B_{FSR}} \times S_{TC} \times S_{TCHall} \times S_o \times V_{DD} \right) + V_{OS}$$

B_{FSR} is the full range magnetic field. It is dependent on the range setting (e.g 100 mT).

S_o is the nominal sensitivity of the Hall probe times the Gain factor set in the EEPROM.

S_{TC} is the temperature-dependent sensitivity factor calculated by the DSP.

S_{TCHall} is the temperature behavior of the Hall probe.

The pre-calibration at Infineon is performed such that the following condition is met:

$$S_{TC}(T_J - T_0) \times S_{TCHall}(T_J) \approx 1$$

Within the application, an additional factor B_{IN}(T) / B_{IN}(T₀) will be given due to the magnetic system. S_{TC} needs now to be modified to S_{TCnew} so that the following condition is satisfied:

$$\frac{B_{IN}(T)}{B_{IN}(T_0)} \times S_{TCnew}(T) \times S_{TCHall}(T) \approx S_{TC}(T) \times S_{TCHall}(T) \approx 1$$

Therefore, the new sensitivity parameters S_{TCnew} can be calculated from the pre-calibrated setup S_{TC} using the relation:

$$\frac{B_{IN}(T)}{B_{IN}(T_0)} \times S_{TCnew}(T) \approx S_{TC}(T)$$

9 Calibration

A special hardware interface to an external computing system and measurement equipment is required for calibration of the sensor. All calibration and setup bits can be written into a random access memory (RAM). This allows the EEPROM to remain untouched during the entire calibration process. Therefore, this temporary setup (using the RAM only) does not stress the EEPROM—and even allows a pre-verification¹⁾ of the setup before programming—as the number of EEPROM programming cycles is limited to provide a high data endurance.

The digital signal processing is completely deterministic. This allows a two point calibration in one step without iterations. The two magnetic fields (here described as two “positions” of an external magnetic circuitry) need to be applied only once. Furthermore, a complete setup and calibration procedure can be performed requiring only one EEPROM programming cycle at the end²⁾.

After setting up the temperature coefficients, the calibrated Hall A/D Converter values of both positions need to be read and the sensor output signals (using a DAC test mode) need to be acquired for the corresponding end points. Using this data, the signal processing parameters can be immediately calculated with a program running on the external computing system.

Note: The calibration and programming process must be performed only at the start of life of the device.

Table 17 Calibration Characteristics

Parameter	Symbol	Limit Values		Unit	Notes
		min.	max.		
Temperature of sensor at 2 point calibration and programming	t_{CAL}	10	60	°C	
2 point calibration accuracy ¹⁾	ΔV_{CAL1}	-10	10	mV	Position 1
	ΔV_{CAL2}	-10	10	mV	Position 2

¹⁾ Setup and validation performed at start of life.

Note: Depending on the application and external instrumentation setup, the accuracy of the 2 point calibration can be improved.

¹⁾ This feature is not required for a deterministic two-point setup to fulfill the specification.

²⁾ Details and basic algorithms for this step are available on request.

9.1 Calibration Data Memory

When the MEMLOCK bits are programmed (two redundant bits), the memory contents are frozen and may no longer be changed. Furthermore, the programming interface is locked out and the chip remains in Application Mode only. This prevents accidental programming due to environmental influences.

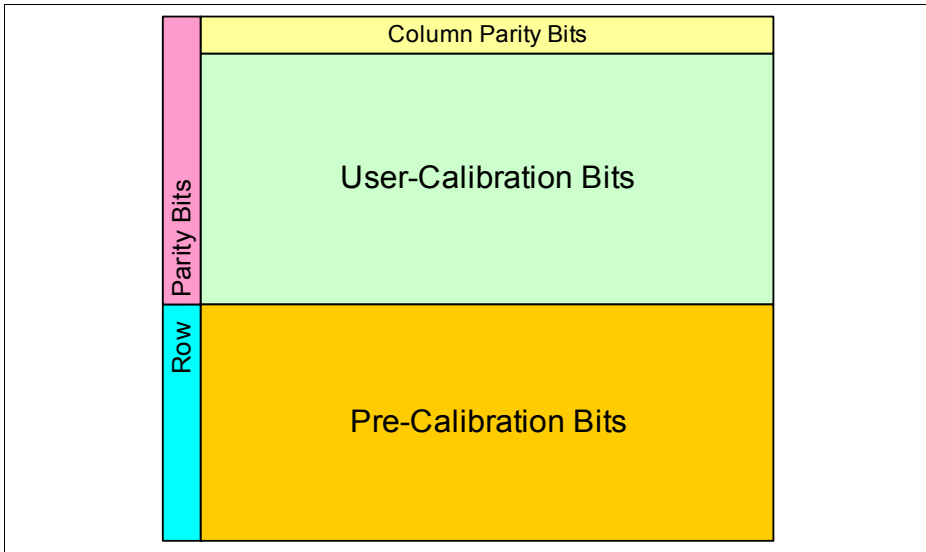

Figure 9 EEPROM Map

A matrix parity architecture allows the automatic correction of any single bit error. Each row is protected by a row parity bit. The sum of bits set including this bit must be an odd number (ODD PARITY). Each column is additionally protected by a column parity bit. The sum of all the bits in the even positions (0, 2, etc.) of all lines must be an even number (EVEN PARITY); the sum of all the bits in the odd positions (1,3, etc.) must be an odd number (ODD PARITY). This mechanism of different parity calculations protects against many block errors (such as erasing a full line or even the entire EEPROM).

When modifying the application bits (such as Gain, Offset, TC, etc.) the parity bits must be updated. For the column bits, the pre-calibration area must be also read out and considered for correct parity generation.

Note: A specific programming algorithm must be followed to ensure the data retention. A separate detailed programming specification is available on request.

Table 18 Programming Characteristics

Parameter	Symbol	Limit Values		Unit	Notes
		min.	max.		
Number of EEPROM programming cycles	N_{PRG}	-	10	Cycles ¹⁾	Programming allowed only at start of lifetime
Ambient temperature at programming	T_{PRG}	10	60	°C	
Programming time	t_{PRG}	100	-	ms	For complete memory ²⁾
Calibration memory	-	135		Bit	All active EEPROM bits
Error correction	-	25		Bit	All parity EEPROM bits

¹⁾ 1 cycle is the simultaneous change of ≥ 1 bit.

²⁾ Depending on clock frequency at VDD, write pulse 10ms $\pm 1\%$, erase pulse 80ms $\pm 1\%$.

9.2 Programming Interface

The supply pin and the output pin are used as two-wire interface to transmit the EEPROM data to and from the sensor.

This allows

- communication with high data reliability
- bus-type connection of several sensors

In many applications, two sensors are used to measure the same parameter. This redundancy allows the operation to continue in an emergency mode. If both sensors use the same power supply lines, they can be programmed together in parallel.

The data transfer protocol and programming is described in a separate document (TLE4997 Programming Guide).

9.3 Laboratory Evaluation Programmer

For the programming of evaluation samples and QA (quality assurance) samples a programming equipment is available on request.

10 Application Circuit

Figure 10 shows the connection of multiple sensors to a microcontroller.

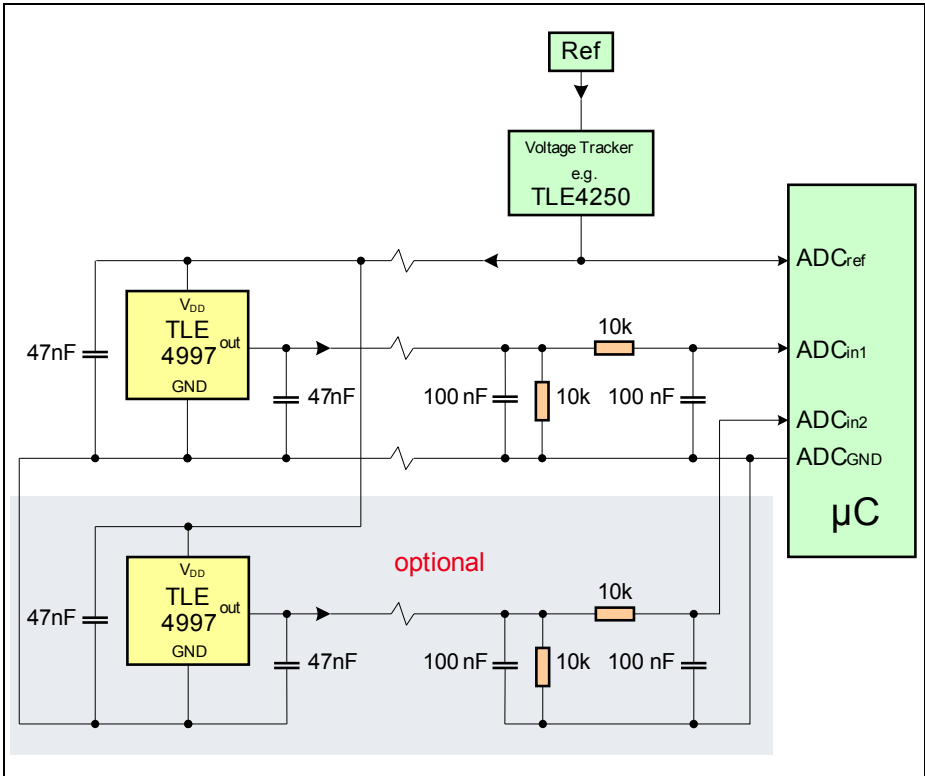

Figure 10 Application Circuit

Note: For calibration and programming, the interface must be connected directly to the output pin.



The given application circuit must be regarded as only an example. It needs to be adapted according to the requirements of the specific application.

www.infineon.com







Published by Infineon Technologies AG

Looking for pricing, stock, or lifecycle information?

Click below to explore more details on WIN SOURCE:

-  [View TLE4997E2 on WIN SOURCE](#)
-  [Infineon Technologies](#) Information

Optimize Your Supply Chain with WIN SOURCE Sol

-  Global Sourcing Solution
-  Obsolete Management
-  Cost Control Management
-  Shortage Management
-  Alternative Solution
-  Excess Inventory Management