



**THE DATASHEET OF
LM2706TLX/NOPB**



LM2706

Miniature, Variable, Step-Down DC-DC Converter with Bypass for RF Power Amplifiers

General Description

The LM2706 DC-DC converter is optimized for powering RF power amplifiers (PAs) from a single Lithium-Ion cell. It may also be used in many other applications. It steps down an input voltage from 2.7V to 5.5V to a variable output from 1.5V to 3.25V up to 300 mA. Output voltage is set using a V_{CON} analog input for controlling power levels and efficiency of the RF PA. An internal bypass switch allows direct connection to the battery for maximum power to the RF PA.

The device offers 4 modes for mobile phones and similar RF PA applications. Fixed-frequency PWM mode minimizes RF interference. Forced Bypass mode turns on an internal bypass switch to power the PA directly from the battery. Automatic bypass mode minimizes dropout by turning on the bypass switch when the battery decays to near the output voltage. Shutdown mode turns the device off and reduces battery consumption to 0.1 μ A (typ.).

The device also offers internal synchronous rectification for high efficiency (95% typ at 3.25 V_{OUT} , 200 mA, 3.9 V_{IN}). Current limit and thermal overload protection protects the device and system during fault conditions.

The LM2706 is available in a 10-pin lead free micro SMD package. This packaging uses National's chip-scale micro SMD technology and offers the smallest possible size. A high switching frequency (600 kHz) allows use of tiny surface-mount components. Only three small external surface-mount components, an inductor and two ceramic capacitors, are required.

Key Specifications

- Operates from a single LiION cell (2.7V to 5.5V)
- Variable output voltage (1.5V to 3.25V)

- $\pm 2\%$ DC output voltage precision
- Internal 105 m Ω (typ) bypass switch
- 300 mA maximum load capability
- 1.4 mA typ quiescent current
- 0.1 μ A typ shutdown current
- 600 kHz PWM switching frequency
- High efficiency (95% typ at 3.9 V_{IN} , 3.25 V_{OUT} at 200 mA) from internal synchronous rectification

Features

- Forced and Automatic Bypass modes
- Miniature 10-pin lead free micro SMD package
- Only three tiny surface-mount external components required
- Uses small ceramic capacitors
- Low output voltage ripple (<10 mV typ)
- Internal soft start
- Current overload protection
- No external compensation

Applications

- Mobile Phones
- Hand-Held Radios
- RF PC Cards
- Battery Powered RF Devices

Typical Application Circuit

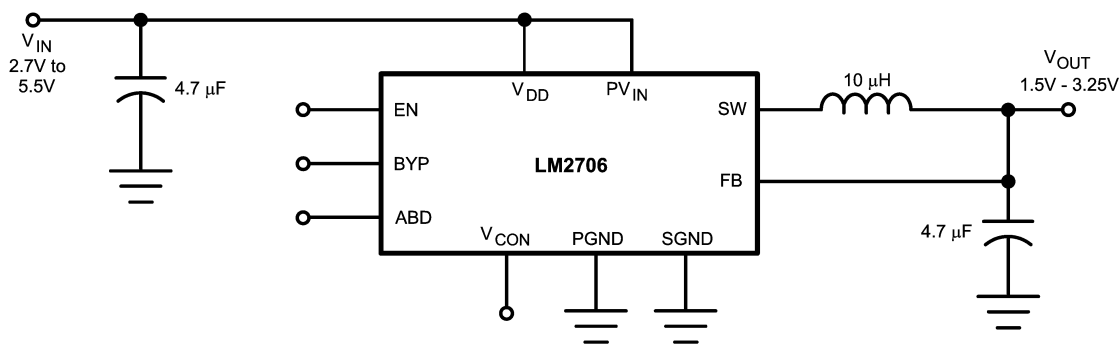

20040901

Connection Diagrams

10-Bump micro SMD Package

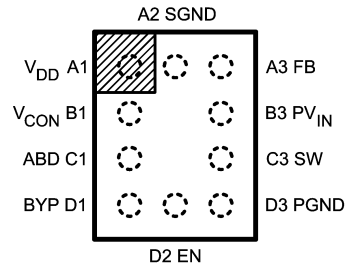

Top View

20040902

10-Bump micro SMD Package

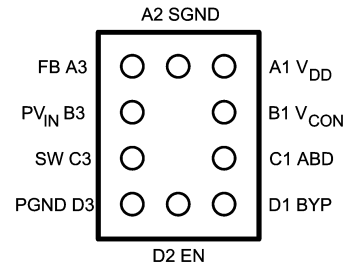

Bottom View

20040903

Ordering Information

Order Number	Package Type	NSC Package Marking (*)	Supplied As
LM2706TL	10-Bump Wafer	XYTT IS64B	250 Tape and Reel
LM2706TLX	Level Chip Scale (micro SMD)		3000 Tape and Reel

(*) XY - denotes the date code marking (2 digit) in production

TT - refers to die run/lot traceability for production

I - pin one indication

S - Product line designator

Note the Package Marking may change over the course of production without notice

Pin Description

Pin Number	Pin Name	Function
A1	V _{DD}	Analog Supply Input. If board layout is not optimum, an optional 0.1 μ F ceramic capacitor is suggested (<i>Figure 1</i>).
B1	V _{CON}	Voltage Control Analog Input. V _{CON} controls V _{OUT} in PWM mode. Set: $V_{CON} \leq 0.55V$ for $V_{OUT} = 1.5V$ $0.65V < V_{CON} < 1.5V$ for $V_{OUT} = 1.75 V_{CON} + 0.45V$ $V_{CON} \geq 1.7V$ for $V_{OUT} = 3.25V$
C1	ABD	Automatic Bypass Disable. Use this digital input to control Automatic Bypass mode. Set: ABD = low to enable automatic bypass mode ABD = high to disable automatic bypass mode
D1	BYP	Bypass. Use this digital input to command operation in Forced Bypass mode. Set BYP = 0V for normal operation.
D2	EN	Enable Input. Set this digital input high for normal operation. For shutdown, set low.
D3	PGND	Power Ground
C3	SW	Switching Node connection to the internal PFET switch and NFET synchronous rectifier.
B3	PV _{IN}	Power Supply Voltage Input to the internal PFET switch. Connect to the input filter capacitor (<i>Figure 1</i>).
A3	FB	Feedback Analog Input. Connect to the output at the output filter capacitor (<i>Figure 1</i>).
A2	SGND	Analog and Control Ground

Absolute Maximum Ratings (Note 1)

If Military/Aerospace specified devices are required, please contact the National Semiconductor Sales Office/Distributors for availability and specifications.

Supply Voltage, PV_{IN} , V_{DD} to SGND	-0.2V to +6V
PGND to SGND	-0.2V to +0.2V
EN, FB, BYP, ABD, V_{CON}	(SGND -0.2V) to (V_{DD} +0.2V)
SW	(PGND -0.2V) to (V_{DD} +0.2V)

PV_{IN} to V_{DD}	-0.2V to +0.2V
Storage Temperature Range	-45°C to +150°C
Lead Temp. (Soldering, 10 sec)	260°C
Junction Temperature (Note 2)	+125°C
Minimum ESD Rating (Human Body Model, C = 100 pF, R = 1.5 kΩ)	±2 kV
Thermal Resistance (θ_{JA}) (Note 3)	137°C/W

Electrical Characteristics

Specifications with standard typeface are for $T_A = T_J = 25^\circ\text{C}$, and those in **boldface type** apply over the full **Operating Temperature Range** of $T_A = T_J = -25^\circ\text{C}$ to $+85^\circ\text{C}$. Unless otherwise specified, $PV_{IN} = V_{DD} = EN = 3.6\text{V}$, $BYP = ABD = V_{CON} = 0\text{V}$.

Symbol	Parameter	Conditions	Min	Typ	Max	Units
V_{IN}	Input Voltage Range (Note 4)	$PV_{IN} = V_{DD} = V_{IN}$	2.7	3.6	5.5	V
$V_{FB, MIN}$	Regulated feedback voltage at minimum setting	$V_{CON} = 0\text{V}$ $T_A = 25^\circ\text{C}$	1.47	1.50	1.53	V
$V_{FB, MIN}$	Regulated feedback voltage at minimum setting	$V_{CON} = 0\text{V}$	1.455	1.50	1.545	V
$V_{FB, MAX}$	Regulated feedback voltage at maximum setting	$V_{CON} = 1.70\text{V}$ $T_A = 25^\circ\text{C}$	3.185	3.25	3.315	V
$V_{FB, MAX}$	Regulated feedback voltage at maximum setting	$V_{CON} = 1.70\text{V}$	3.15	3.25	3.35	V
OVP	Over-Voltage protection Threshold	$V_{CON} = 0\text{V}$ (Note 5)	260	350	445	mV
$V_{BYPASS-}$	Auto Bypass Detection Threshold	$V_{CON} = 1.7\text{V}$ (Note 6)	160	275	390	mV
$V_{BYPASS+}$	Auto Bypass Detection Threshold	$V_{CON} = 1.7\text{V}$ (Note 6)	310	440	570	mV
I_{SHDN}	Shutdown Supply Current	EN = ABD = BYP = SW = FB = 0V $T_A = 25^\circ\text{C}$ (Note 7)		0.1	1	μA
I_{SHDN}	Shutdown Supply Current	EN = ABD = BYP = SW = FB = 0V $T_A = 55^\circ\text{C}$ (Note 7)		0.45	2	μA
I_{SHDN}	Shutdown Supply Current	EN = ABD = BYP = SW = FB = 0V $T_A = 85^\circ\text{C}$ (Note 7)		6	25	μA
I_{Q1_PWM}	DC Bias Current into V_{DD}	FB = 2V, No-Load, $V_{CON} = 0\text{V}$ $V_{IN} = \text{BYP} = 3.6\text{V}$, No-Load, $V_{CON} = 0\text{V}$		1.4	1.8	mA
I_{Q2_BYPASS}				1.45	1.8	
$R_{DSON(P)}$	Pin-Pin Resistance for P FET			260	500	mΩ
$R_{DSON(N)}$	Pin-Pin Resistance for N FET			200	500	mΩ
$R_{DSON(BYP)}$	Pin-Pin Resistance for Bypass FET			105	200	mΩ
$I_{LIM, PFET}$	Switch Peak Current Limit	(Note 8)	550	650	750	mA
$I_{LIM, BYPASS}$	Bypass FET Peak Current Limit	(Note 8)	480	650	930	mA
F_{OSC}	Internal Oscillator Frequency		500	600	700	kHz
V_{IH}	Logic High Input, EN, BYP, ABD				1.2	V
V_{IL}	Logic Low Input, EN, BYP, ABD		0.5			V
I_{PIN}	Pin Pull Down Current, EN, BYP, ABD	EN, BYP, ABD = 3.6V		5	10	μA
$V_{CON, MIN}$	V_{CON} Threshold Commanding $V_{FB, MIN}$	PWM Mode, V_{CON} Swept Down	0.55	0.6	0.65	V
$V_{CON, MAX}$	V_{CON} Threshold Commanding $V_{FB, MAX}$	PWM Mode, V_{CON} Swept Up	1.5	1.6	1.7	V
Z_{CON}	V_{CON} Input Resistance		100			kΩ

Electrical Characteristics (Continued)

Note 1: Absolute Maximum Ratings indicate limits beyond which damage to the device may occur. Operating Ratings indicate conditions for which the device is functional, but device specifications may not be guaranteed. For guaranteed specifications and associated test conditions, see the Min and Max limits and Conditions in the Electrical Characteristics table. Electrical characteristics table limits are guaranteed by production testing, design or correlation using standard Statistical Quality Control methods. Typical (typ) specifications are mean or average values at 25°C and are not guaranteed.

Note 2: Thermal shutdown will occur if the junction temperature exceeds 150°C.

Note 3: Thermal resistance specified with 1.2" x 1.2" (2 layer 1.5 oz. Cu.) board.

Note 4: The LM2706 is designed for mobile phone applications where turn-on after power-up is controlled by the system controller and where requirements for a small package size overrule increased die size for internal Under Voltage Lock-Out (UVLO) circuitry. Thus, it should be kept in shutdown by holding the EN pin low until the input voltage exceeds 2.7V.

Note 5: Over-Voltage protection (OVP) hysteresis is the voltage above the nominal V_{OUT} where the OVP comparator turns off the PFET switch while in PWM mode.

Note 6: V_{IN} is compared to the programmed output voltage ($V_{OUT, PROG}$). When $V_{IN}-V_{OUT, PROG}$ falls below $V_{BYPASS-}$ for longer than T_{BYPASS} the bypass FET turns on and the switching FETS turn off. This is called the bypass mode. Bypass mode is exited when $V_{IN}-V_{OUT, PROG}$ exceeds $V_{BYPASS+}$ for longer than T_{BYPASS} , and PWM mode returns.

Note 7: Shutdown current includes the leakage currents of the PFET and Bypass FET.

Note 8: Current limit is built-in, fixed, and not adjustable. The current limit tests are done by using DC measurement methods.

System Characteristics The following specifications are based on design limits and assume that the component values in the typical application circuit are used. **These parameters are not guaranteed by production testing.**

Symbol	Parameter	Conditions	Min	Typ	Max	Units
Tresponse	Time for V_{OUT} to rise from 1.5V to 3.25V (PWM Mode)	$V_{IN} = 4.2V, C_{OUT} = 4.7 \mu F,$ $R_{LOAD} = 15 \Omega$		25	30	μs
Ton_pwm	Turn on time in pwm mode	EN = L to H, $V_{IN}=3.6V, V_{OUT}=3.25V,$ $C_{OUT} = 4.7 \mu F, R_{LOAD}=10 \Omega$		600	900	μs
ZCON	V_{CON} input capacitance	$V_{CON}=1V, \text{Test freq} = 100kHz$			15	pF
T_bypass	Auto bypass detect delay	(Note 6)	8	10	12	μs
Ton_bypass	Bypass FET turn on time	$V_{IN} - V_{OUT} = 0.25V$ $C_{OUT} = 4.7\mu F, R_{LOAD} = 15 \Omega$			30	μs

Typical Performance Characteristics (Circuit of Figure 1, $V_{IN} = EN = 3.6V$, $ABD = BYP = 0V$, $T_A = 25^\circ C$, unless otherwise noted.)

Quiescent Supply Current vs Temperature

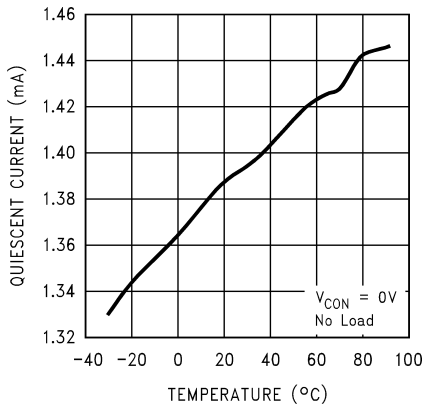

20040984

Quiescent Supply Current vs Supply Voltage

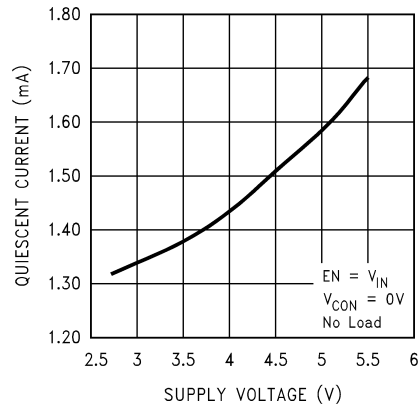

20040985

Shutdown Supply Current vs Temperature

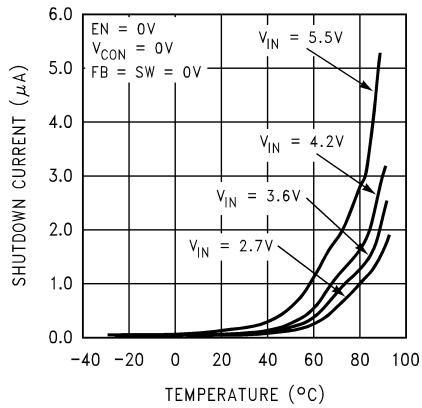

20040986

Switching Frequency vs Temperature

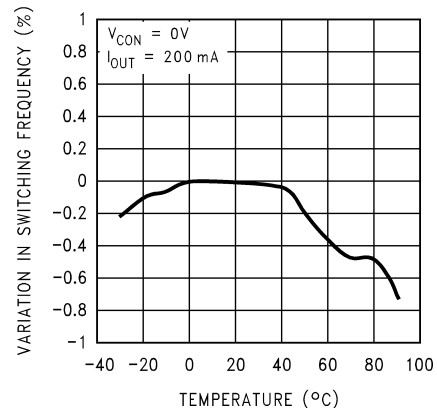

20040987

Output Voltage vs Temperature ($V_{OUT} = 1.5V$)

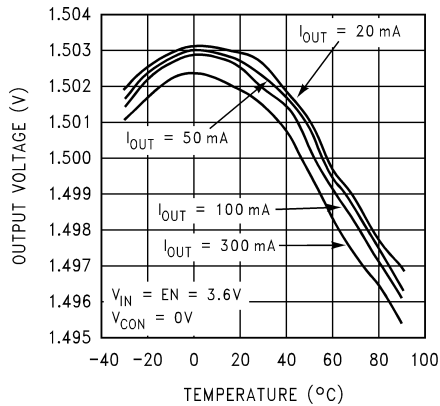

20040988

Output Voltage vs Temperature ($V_{OUT} = 3.25V$)

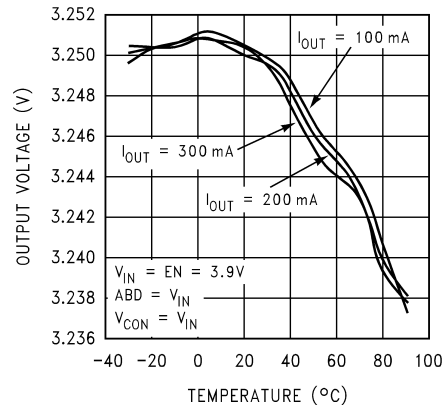

20040989

Typical Performance Characteristics (Circuit of Figure 1, $V_{IN} = EN = 3.6V$, $ABD = BYP = 0V$, $T_A = 25^\circ C$, unless otherwise noted.) (Continued)

Output Voltage vs Supply Voltage
($V_{OUT} = 1.5V$)

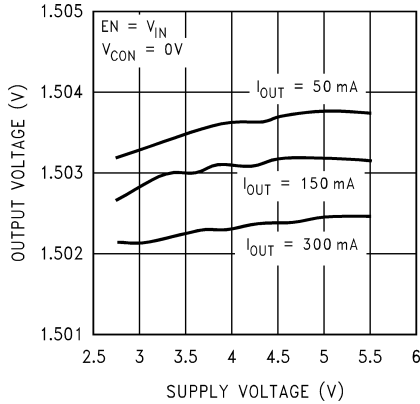

Output Voltage vs Output Current
($V_{OUT} = 1.5V$)

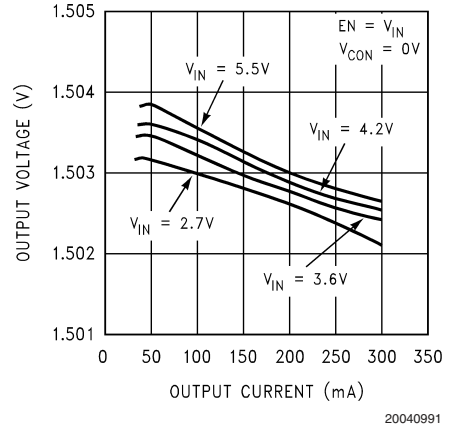

Output Voltage vs Output Current
($V_{OUT} = 3.25V$)

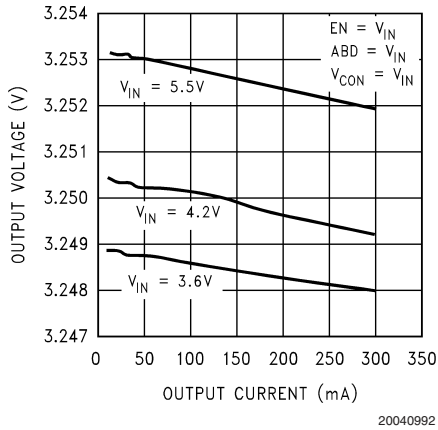

Dropout Voltage vs Output Current

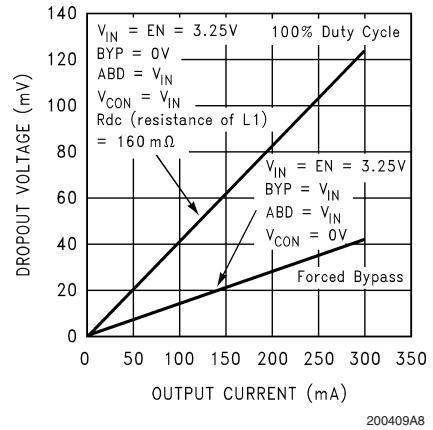

Efficiency vs Output Current
($V_{OUT} = 1.5V$)

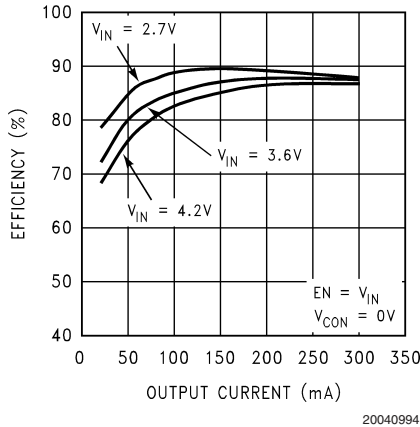

Efficiency vs Output Current
($V_{OUT} = 3.25V$)

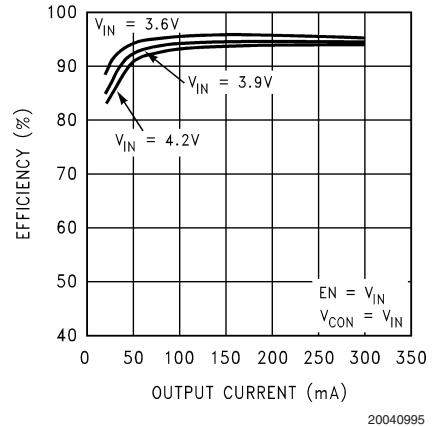

Typical Performance Characteristics (Circuit of *Figure 1*, $V_{IN} = EN = 3.6V$, $ABD = BYP = 0V$, $T_A = 25^\circ C$, unless otherwise noted.) (Continued)

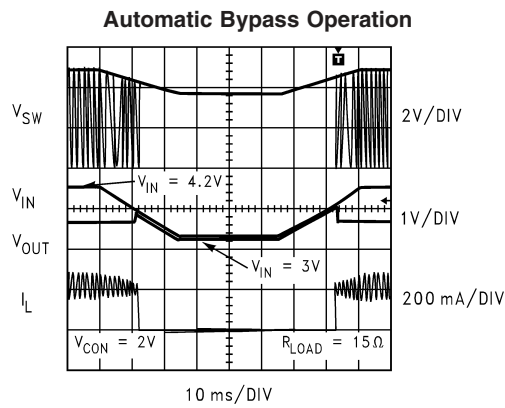
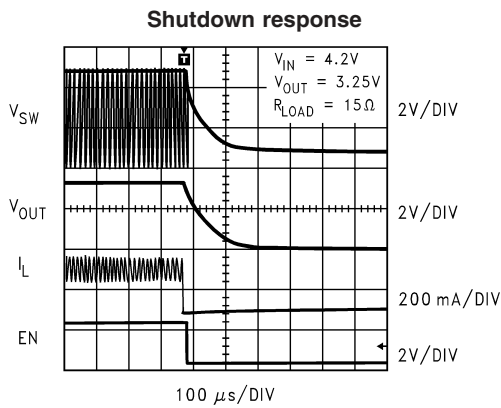
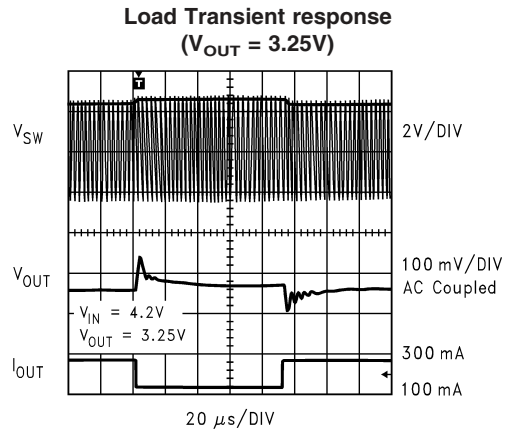
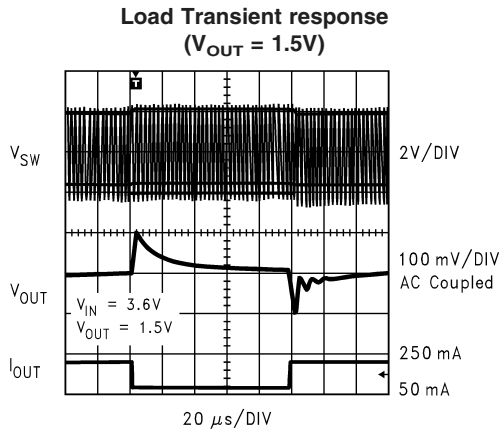
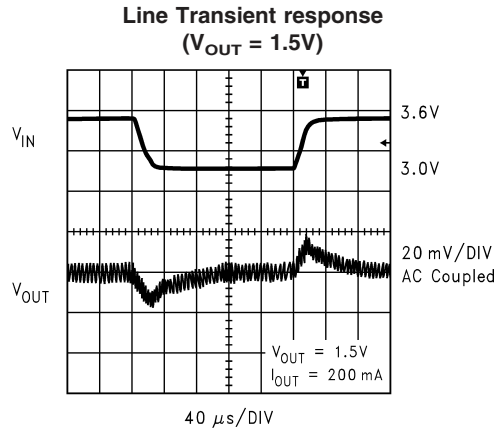
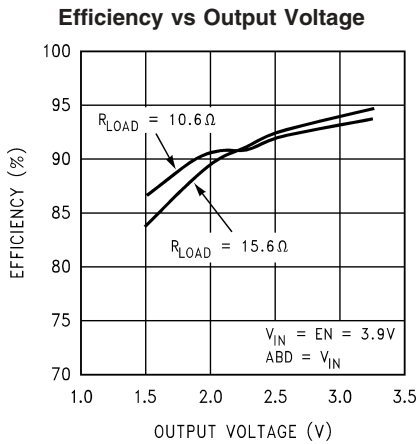

Typical Performance Characteristics

(Circuit of Figure 1, $V_{IN} = EN = 3.6V$, $ABD = BYP = 0V$, $T_A = 25^\circ C$, unless otherwise noted.) (Continued)

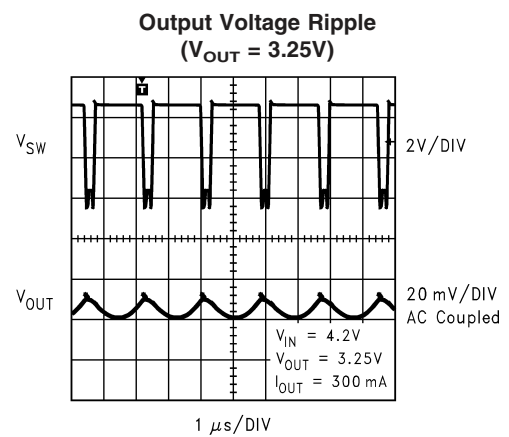
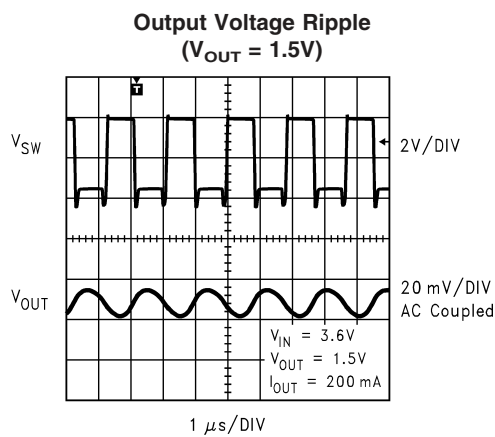
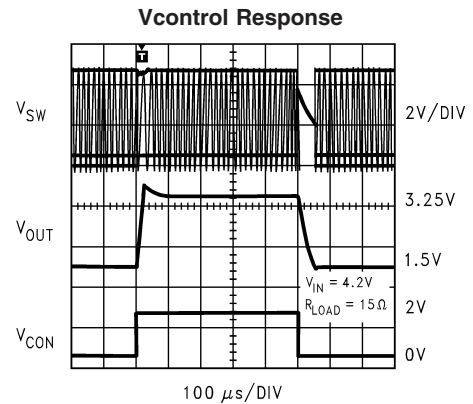
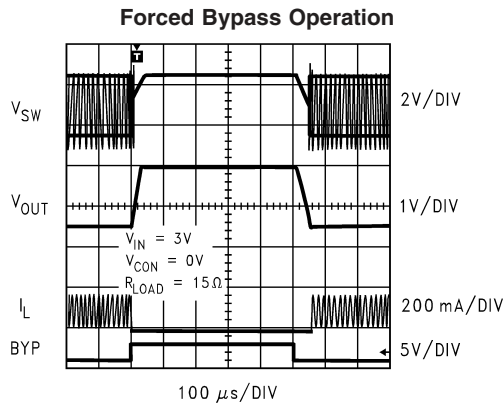

Device Information

The LM2706 is a simple, step-down DC-DC converter and bypass switch optimized for powering RF power amplifiers (PAs) in mobile phones, portable communicators, and similar battery powered RF devices. It is designed to allow the RF PA to operate at maximum efficiency over a wide range of power levels from a single LiION battery cell. It is based on a current-mode buck architecture, with synchronous rectification for high efficiency. It is designed for a maximum load capability of 300 mA. Maximum load range may vary from this depending on input voltage, output voltage and the inductor chosen.

The device has all four of the pin-selectable operating modes required for powering RF PAs in mobile phones and other sophisticated portable devices with complex power management needs. Fixed-frequency PWM operation offers regulated output at high efficiency while minimizing interference with sensitive IF and data acquisition circuits. Forced Bypass mode turns on an internal FET bypass switch to power the PA directly from the battery. Automatic Bypass mode turns on the bypass switch when the input voltage gets close to the set output voltage. This helps the RF power amplifier maintain its operating power during low battery conditions by reducing the dropout voltage across the LM2706. Shutdown mode turns the device off and reduces battery consumption to 0.1 μA (typ).

DC PWM mode output voltage precision is $\pm 2\%$. Efficiency is typically around 95% for a 200 mA load with 3.25V output,

3.9V input. The output voltage is dynamically programmable from 1.5V to 3.25V by adjusting the voltage on the control pin without the need for external feedback resistors. This ensures longer battery life by being able to change the PA supply voltage dynamically depending on its transmitting power.

Additional features include soft-start, current overload protection, over voltage protection and thermal overload protection.

The LM2706 is constructed using a chip-scale 10-pin micro SMD package. This package offers the smallest possible size, for space-critical applications such as cell phones, where board area is an important design consideration. Use of a high switching frequency (600 kHz) reduces the size of external components. As shown in Figure 1, only three external power components are required for implementation. Use of a micro-SMD package requires special design considerations for implementation. (See *Micro SMD Package Assembly and Use* in the *Applications Information* section.) Its fine bump-pitch requires careful board design and precision assembly equipment. Use of this package is best suited for opaque-case applications, where its edges are not subject to high-intensity ambient red or infrared light. Also, the system controller should set EN low during power-up and other low supply voltage conditions. (See *Shutdown Mode* in the *Device Information* section.)

Device Information (Continued)

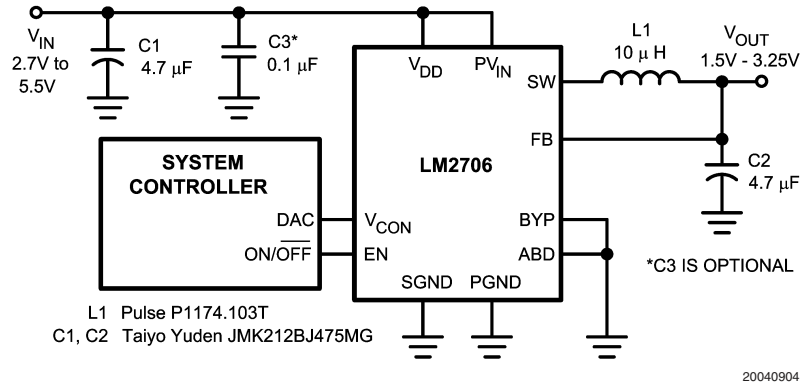

FIGURE 1. Typical Operating Circuit

Circuit Operation

Referring to *Figures 1, 2, 3*, the LM2706 operates as follows. During the first part of each switching cycle, the control block in the LM2706 turns on the internal PFET switch. This allows current to flow from the input through the inductor to the output filter capacitor and load. The inductor limits the current to a ramp with a slope of around $(V_{IN} - V_{OUT})/L$, by storing energy in a magnetic field. During the second part of each cycle, the controller turns the PFET switch off, blocking current flow from the input, and then turns the NFET synchronous rectifier on. In response, the inductor's magnetic field collapses, generating a voltage that forces current from ground through the synchronous rectifier to the output filter capacitor and load. As the stored energy is transferred back

into the circuit and depleted, the inductor current ramps down with a slope around V_{OUT}/L . If the inductor current reaches zero before the next cycle, the synchronous rectifier is turned off to prevent current reversal. The output filter capacitor stores charge when the inductor current is high, and releases it when low, smoothing the voltage across the load.

The output voltage is regulated by modulating the PFET switch on time to control the average current sent to the load. The effect is identical to sending a duty-cycle modulated rectangular wave formed by the switch and synchronous rectifier at SW to a low-pass filter formed by the inductor and output filter capacitor. The output voltage is equal to the average voltage at the SW pin.

Circuit Operation (Continued)

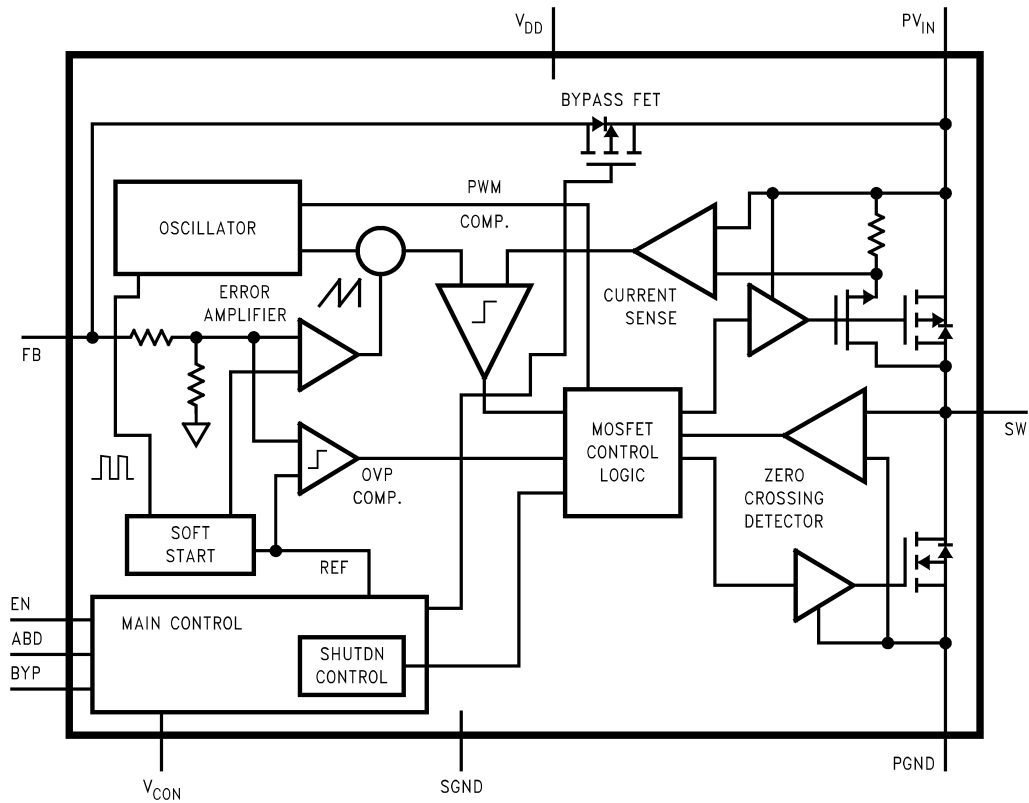

20040905

FIGURE 2. Simplified Functional Diagram

PWM Operation

While in PWM (Pulse Width Modulation) mode, the output voltage is regulated by switching at a constant frequency and then modulating the energy per cycle to control power to the load. Energy per cycle is set by modulating the PFET switch on-time pulse-width to control the peak inductor current. This is done by comparing the signal from the current-sense amplifier with a slope compensated error signal from the voltage-feedback error amplifier. At the beginning of each cycle, the clock turns on the PFET switch, causing the inductor current to ramp up. When the current sense signal ramps past the error amplifier signal, the PWM comparator turns off the PFET switch and turns on the NFET synchronous rectifier, ending the first part of the cycle. If an increase in load pulls the output down, the error amplifier output increases, which allows the inductor current to ramp higher before the comparator turns off the PFET. This increases the average current sent to the output and adjusts for the increase in the load.

Before going to the PWM comparator, the error signal is summed with a slope compensation ramp from the oscillator for stability of the current feedback loop. During the second part of the cycle, a zero crossing detector turns off the NFET synchronous rectifier if the inductor current ramps to zero. The minimum on time of PFET in PWM mode is 200 ns.

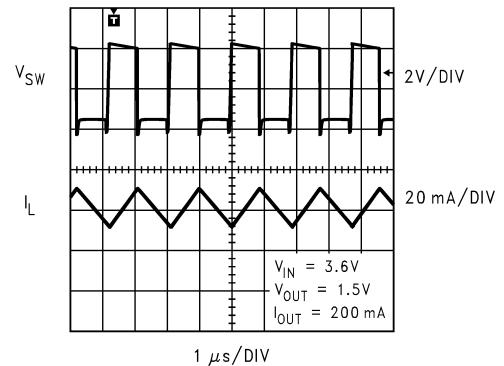

200409A7

FIGURE 3. Typical Circuit Waveforms in PWM Mode

Bypass Operation

The LM2706 contains an internal PFET switch for bypassing the PWM DC-DC converter during Forced and Automatic Bypass modes. In Forced Bypass mode, this switch is turned on to power the PA directly from the battery for maximum RF output power. Automatic Bypass mode turns on the bypass switch when the input voltage approaches the programmed output voltage so that the RF PA can continue to operate with good linearity at high power levels when the battery voltage is low. When the part operates in the Forced or

Bypass Operation (Continued)

Automatic Bypass modes, the output voltage will follow the input voltage less the voltage drop across the resistance of the bypass PFET. These modes are more efficient than operating in PWM mode at 100% duty cycle because the resistance of the bypass PFET is less than the series resistance of the PWM PFET and inductor. This translates into higher voltage available on the output in bypass mode, for a given battery voltage.

The part can be placed in bypass operation by sending BYP pin high for Forced Bypass mode. During Forced Bypass mode, the bypass switch remains on irrespective of the state of ABD pin. A second way to place the part in bypass operation is by setting ABD low for Automatic Bypass mode. In Automatic Bypass mode, the bypass switch turns on when the difference between the input voltage and programmed output voltage is less than 275 mV (typ) for more than the bypass delay time 10 μ s (typ). The bypass switch turns off when the input voltage is higher than the programmed output voltage by 440 mV (typ) for longer than the bypass delay time. The bypass delay time is provided to prevent false triggering into Automatic Bypass Mode modes by either spikes or dips in V_{IN} .

Operating Mode Selection Controls

The LM2706 is designed for digital control of the operating modes using BYP and ABD pins. The settings for these pins are outlined in *Table 1*. Setting BYP high ($>1.2V$) places the device in Forced Bypass mode. Setting BYP low and ABD high forces operation in PWM mode. Setting both BYP and ABD low ($<0.5V$) or leaving them floating places the device in Automatic Bypass mode. The BYP and ABD pins have 5 μ A (typ) pull down currents for default operation in Automatic Bypass mode for automatic switchover between PWM and Bypass operation in systems where digital mode control is not required.

TABLE 1. Operating Modes

Mode	Logic Level	
	ABD	BYP
Forced Bypass	0 or 1	1
Auto-Bypass / PWM	0	0
PWM	0 or 1	0

Overvoltage Protection

The LM2706 has an over-voltage comparator that prevents the output voltage from rising too high, when the device is left in PWM mode under low-load conditions. When the output voltage rises by 350 mV over its regulation threshold, the OVP comparator inhibits PWM operation to skip pulses until the output voltage returns to the regulation threshold. In over voltage protection, output voltage and ripple increases. At light loads when the required on time to regulate becomes less than the minimum on time of the LM2706 (around 200ns) then the output voltage will increase till it hits the overvoltage threshold and the part will be in overvoltage protection mode.

Shutdown Mode

Setting the EN digital input pin low ($<0.5V$) places the LM2706 in a 0.1 μ A (typ) shutdown mode. During shutdown,

the PFET switch, NFET synchronous rectifier, reference, control and bias circuitry of the LM2706 are turned off. Setting EN high enables normal operation. While turning on, soft start is activated. The device takes around 600 μ s to complete the soft-start interval and come into regulation during turn-on.

EN should be set low to turn off the LM2706 during power-up and under voltage conditions when the supply is less than the 2.7V minimum operating voltage. The LM2706 is designed for compact portable applications, such as mobile phones. In such applications, the system controller determines power supply sequencing and requirements for small package size outweigh the additional size required for inclusion of UVLO (Under Voltage Lock-Out) circuitry.

Internal Synchronous Rectification

While in PWM mode, the LM2706 uses an internal NFET as a synchronous rectifier to reduce rectifier forward voltage drop and associated power loss. Synchronous rectification provides a significant improvement in efficiency whenever the output voltage is relatively low compared to the voltage drop across an ordinary rectifier diode.

During moderate and heavy loads, the internal NFET synchronous rectifier is turned on during the inductor current down slope during the second part of each cycle. The synchronous rectifier is turned off prior to the next cycle, or when the inductor current ramps to zero at light loads. The NFET is designed to conduct through its intrinsic body diode during transient intervals before it turns on, eliminating the need for an external diode.

Current Limiting

A current limit feature allows the LM2706 to protect itself and external components during overload conditions. In PWM mode a 750 mA max cycle-by-cycle current limit is normally used.

In the Bypass mode the bypass FET peak current limit is 650 mA (typ). During overload conditions the LM2706 limits output current to this value. If the output current reaches the bypass FET peak current limit then the current folds back to the fold back current value of around 450 mA. A reduction in the output current below the reset value of around 300 mA resumes normal bypass operation.

In cases where the bypass FET is turned on with a big differential between the input and output voltages the bypass FET may see a peak current exceeding its peak current limit due to the charging of the output capacitor plus the load current and will go to the foldback current value thus acting as a constant current source. As the output capacitor gets charged the bypass FET current will go below the reset limit and the bypass switch will be fully on thus acting as a switch again.

Dynamically Adjustable Output Voltage

The LM2706 features dynamically adjustable output voltage to eliminate the need for external feedback resistors. The output can be set from 1.5V to 3.25V by changing the voltage on the analog $V_{CONTROL}$ pin. This feature is useful in PA applications where peak power is needed only when the handset is far away from the base station or when data is being transmitted. In other instances the transmitting power can be reduced and hence the supply voltage to the PA can

Dynamically Adjustable Output Voltage

(Continued)

be reduced helping maintain longer battery life. See *Setting the Output Voltage* in the *Application Information* section for further details.

Soft-Start

The LM2706 has soft start to reduce inrush during power-up and startup. This reduces stress on the LM2706 and external components. It also reduces startup transients on the power source. Soft start is implemented by ramping up the reference input to the error amplifier of the LM2706 to gradually increase the output voltage. The reference ramps up in around 600 μ s.

Thermal Overload Protection

The LM2706 has a thermal overload protection function that operates to protect itself from short-term misuse and overload conditions. When the junction temperature exceeds around 150°C, the device initiates a soft-start cycle which is completed after the temperature drops below 130°C. Prolonged operation in thermal overload conditions may damage the device and is considered bad practice.

Application Information

SETTING THE OUTPUT VOLTAGE

The LM2706 features a pin-controlled variable output voltage to eliminate the need for external feedback resistors. Select an output voltage from 1.5V to 3.25V by setting the voltage on the V_{CON} output voltage control pin, as directed in *Table 2*.

When the control pin voltage is between 0.65V and 1.5V, the output voltage will vary in a monotonic fashion with respect to the voltage on the control pin as per the above equation. Internally the control pin is buffered and then clamped before it is fed to the error amplifier inputs. If voltage on the control

pin is less than 0.55V, the output voltage is regulated at 1.5V and if the voltage is greater than 1.7V, the output is regulated at 3.25V.

TABLE 2. Output Voltage Selection

V_{CON} (V)	V_{OUT} (V)
$V_{CON} \leq 0.55$	1.5
$0.65 < V_{CON} < 1.5$	$V_{OUT} = 1.75 V_{CON} + 0.45V$
$V_{CON} \geq 1.7$	3.25

Refer to *Figure 4* for the relation between V_{OUT} and V_{CON} .

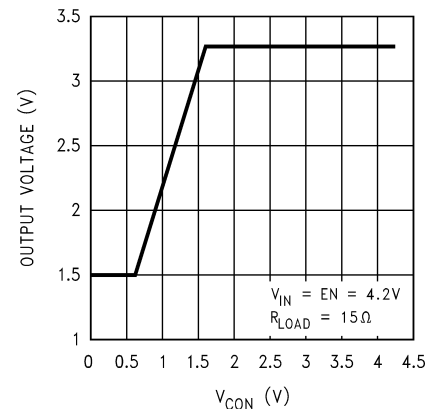

200409A9

FIGURE 4. V_{OUT} vs V_{CON}

INDUCTOR SELECTION

Use a 10 μ H inductor with a saturation current rating of at least 750 mA. The inductor's resistance should be less than around 0.3 Ω for good efficiency. *Table 3* lists suggested inductors and suppliers.

TABLE 3. Suggested Inductors and Their Suppliers

Part Number	Vendor	Phone	FAX
DO1608C-103	Coilcraft	847-639-6400	847-639-1469
P1174.103T	Pulse	858-674-8100	858-674-8262
ELL6RH100M	Panasonic	714-373-7366	714-373-7323
CDRH5D18-100	Sumida	847-956-0666	847-956-0702

For low-cost applications, an unshielded bobbin inductor is suggested. For noise critical applications, a toroidal or shielded-bobbin inductor should be used. A good practice is to lay out the board with footprints accommodating both types for design flexibility. This allows substitution of a low-noise toroidal inductor, in the event that noise from low-cost bobbin models is unacceptable. The saturation current rating is the current level beyond which an inductor loses its inductance. Beyond this rating, the inductor loses its ability to limit current through the PWM switch to a ramp. This can cause poor efficiency, regulation errors or stress to DC-DC converters like the LM2706. Saturation occurs when the

magnetic flux density from current through the windings of the inductor exceeds what the inductor's core material can support with a corresponding magnetic field.

CAPACITOR SELECTION

Use a 4.7 μ F ceramic input capacitor and a 4.7 μ F ceramic output capacitor. These provide an optimal balance between small size, cost, reliability and performance for cell phones and similar applications. *Table 4* lists suggested capacitors and suppliers.

Application Information (Continued)

TABLE 4. Suggested Capacitors and Their Suppliers

Model	Type	Vendor	Phone	FAX
4.7 μ F for C1, C2 (Input or Output Capacitor)				
JMK212BJ475MG	Ceramic	Taiyo-Yuden	847-925-0888	847-925-0899
LMK316BJ475ML	Ceramic	Taiyo-Yuden	847-925-0888	847-925-0899
C2012X5R0J475K	Ceramic	TDK	847-803-6100	847-803-6296

The input filter capacitor supplies current to the PFET switch of the LM2706 in the first part of each cycle and reduces voltage ripple imposed on the input power source. The output filter capacitor smooths out current flow from the inductor to the load, helps maintain a steady output voltage during transient load changes and reduces output voltage ripple. These capacitors must be selected with sufficient capacitance and sufficiently low ESR to perform these functions.

The ESR, or equivalent series resistance, of the filter capacitors is a major factor in voltage ripple. The contribution from ESR to voltage ripple is around 75%–95% for most types of electrolytic capacitors, and less for ceramic capacitors. The remainder of the ripple is from charge storage due to capacitance.

OPERATING MODE SELECTION

Drive the ABD and BYP pins using the system controller to set the operating mode of the LM2706. See *Table 1* for the pin settings and corresponding operating modes. Use a comparator, Schmitt trigger or logic gate to drive the ABD and BYP pins. Drive the pins below 0.5V for a low logic level and above 1.2V for a high logic level. In systems where operation in Automatic Bypass mode is desired and digital control of operating modes is unnecessary, connect ABD and BYP to SGND. ABD and BYP have pull-down currents and will default to Automatic Bypass mode if left floating.

EN PIN CONTROL

Drive the EN pin using the system controller to turn the LM2706 ON and OFF. Use a comparator, Schmitt trigger or logic gate to drive the EN pin. Set EN high (>1.2V) for normal operation and low (<0.5V) for a 0.1 μ A (typ) shut-down mode.

Set EN low to turn off the LM2706 during power-up and under voltage conditions when the supply is less than the 2.7V minimum operating voltage. The LM2706 is designed for mobile phones where the system controller controls operation mode for maximizing battery life and requirements for small package size outweigh the additional size required for inclusion of UVLO (Under Voltage Lock-Out) circuitry.

micro SMD PACKAGE ASSEMBLY AND USE

Use of the micro-SMD package requires specialized board layout, precision mounting and careful reflow techniques, as detailed in National Semiconductor Application Note 1112. Refer to the section *Surface Mount Technology (SMT) Assembly Considerations*. For best results in assembly, alignment ordinals on the PC board should be used to facilitate placement of the device.

The pad style used with Micro SMD package must be the NSMD (non-solder mask defined) type. This means that the solder-mask opening is larger than the pad size. This prevents a lip that otherwise forms if the solder-mask and pad

overlap, from holding the device off the surface of the board and interfering with mounting. See Applications Note 1112 for specific instructions how to do this.

The 10-Bump package used for the LM2706 has 300 micron solder balls and requires 10.82 mil pads for mounting on the circuit board. The trace to each pad should enter the pad with a 90° entry angle to prevent debris from being caught in deep corners. Initially, the trace to each pad should be 6–7 mil wide, for a section approximately 6 mil long, as a thermal relief. Then each trace should neck up or down to its optimal width. The important criterion is symmetry. This ensures the solder bumps on the LM2706 re-flow evenly and that the device solders level to the board. In particular, special attention must be paid to the pads for bumps 6–8. Because PGND and PV_{IN} are typically connected to large copper planes, inadequate thermal relief's can result in late or inadequate reflow of these bumps.

The micro SMD package is optimized for the smallest possible size in applications with red or infrared opaque cases. Because the micro SMD package lacks the plastic encapsulation characteristic of larger devices, it is vulnerable to light. Backside metallization and/or epoxy coating, along with front-side shading by the printed circuit board, reduce this sensitivity. However, the package has exposed die edges. In particular, micro SMD devices are sensitive to light, in the red and infrared range, shining on the package's exposed die edges.

Do not use or power-up the LM2706 while subjecting it to red or infrared light otherwise degraded, unpredictable or erratic operation may result. Examples of light sources with high red or infrared content include the sun and halogen lamps. Package the circuit in a case opaque to red or infrared light.

BOARD LAYOUT CONSIDERATIONS

PC board layout is an important part of DC-DC converter design. Poor board layout can disrupt the performance of a DC-DC converter and surrounding circuitry by contributing to EMI, ground bounce, and resistive voltage loss in the traces. These can send erroneous signals to the DC-DC converter IC, resulting in poor regulation or instability. Poor layout can also result in reflow problems leading to poor solder joints between the Micro SMD package and board pads. Poor solder joints can result in erratic or degraded performance. Good layout for the LM2706 can be implemented by following a few simple design rules.

1. Place the LM2706 on 10.82 mil (10.82/1000 in.) pads. As a thermal relief, connect to each pad with a 7 mil wide, approximately 7 mil long traces, and then incrementally increase each trace to its optimal width. The important criterion is symmetry to ensure the solder bumps on the LM2706 re-flow evenly (see *Micro SMD Package Assembly and Use*).
2. Place the LM2706, inductor and filter capacitors close together and make the traces short. The traces between these components carry relatively high switching currents

Application Information (Continued)

and act as antennas. Following this rule reduces radiated noise. Place the capacitors and inductor within 0.2 in (5 mm) of the LM2706.

3. *Arrange the components so that the switching current loops curl in the same direction.* During the first half of each cycle, current flows from the input filter capacitor, through the LM2706 and inductor to the output filter capacitor and back through ground, forming a current loop. In the second half of each cycle, current is pulled up from ground, through the LM2706 by the inductor, to the output filter capacitor and then back through ground, forming a second current loop. Routing these loops so the current curls in the same direction prevents magnetic field reversal between the two half-cycles and reduces radiated noise.
4. *Connect the ground pins of the LM2706, and filter capacitors together using generous component-side copper fill as a pseudo-ground plane. Then, connect this to the ground-plane (if one is used) with several vias.* This reduces ground-plane noise by preventing the switching currents from circulating through the ground plane. It also reduces ground bounce at the LM2706 by giving it a low-impedance ground connection.
5. *Use wide traces between the power components and for power connections to the DC-DC converter circuit.* This reduces voltage errors caused by resistive losses across the traces. Because the FB trace of the LM2706 carries current from the bypass switch, this trace must also be wide.
6. *Route noise sensitive traces, such as the voltage feedback path, away from noisy traces between the power components.* The voltage feedback trace must remain close to the LM2706 circuit and should be routed directly from FB to V_{OUT} at the output capacitor and should be routed opposite to noisy components. This reduces EMI radiated onto the DC-DC converter's own voltage feedback trace.

Physical Dimensions inches (millimeters)

unless otherwise noted

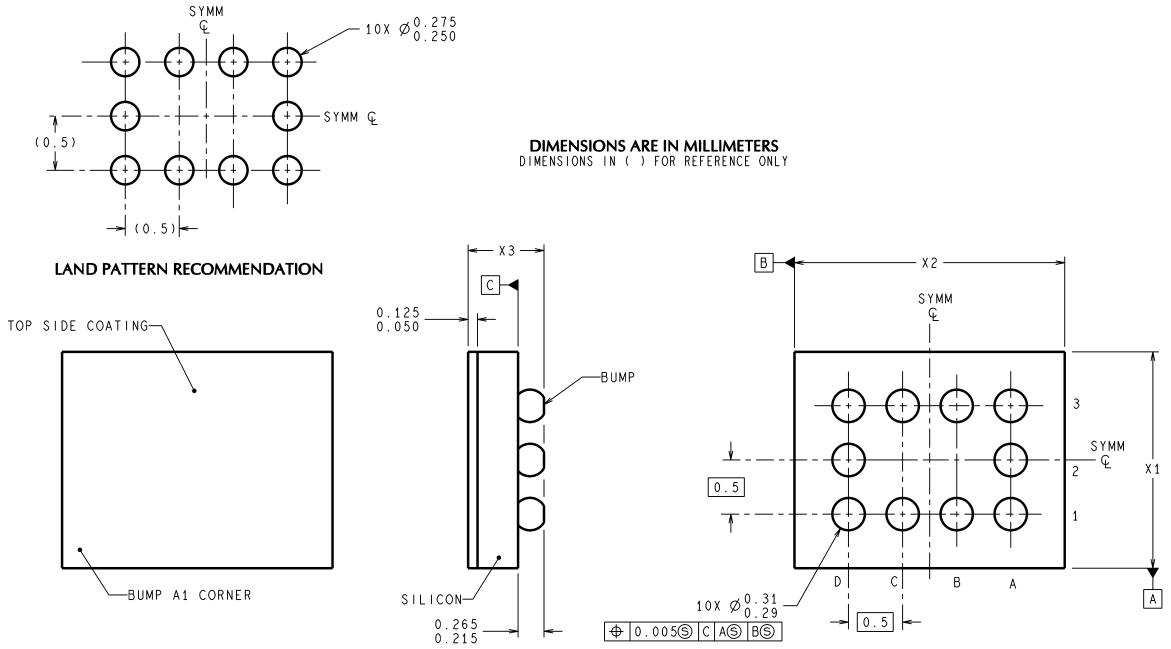

10-Bump micro SMD Package
Order Number LM2706TL or LM2706TLX
NS Package Number TLP10VWA
The dimensions for X1, X2 and X3 are as given:
X1 = 1.996 +/- 0.030mm
X2 = 2.504 +/- 0.030mm
X3 = 0.600 +/- 0.075mm

LIFE SUPPORT POLICY

NATIONAL'S PRODUCTS ARE NOT AUTHORIZED FOR USE AS CRITICAL COMPONENTS IN LIFE SUPPORT DEVICES OR SYSTEMS WITHOUT THE EXPRESS WRITTEN APPROVAL OF THE PRESIDENT AND GENERAL COUNSEL OF NATIONAL SEMICONDUCTOR CORPORATION. As used herein:

1. Life support devices or systems are devices or systems which, (a) are intended for surgical implant into the body, or (b) support or sustain life, and whose failure to perform when properly used in accordance with instructions for use provided in the labeling, can be reasonably expected to result in a significant injury to the user.
2. A critical component is any component of a life support device or system whose failure to perform can be reasonably expected to cause the failure of the life support device or system, or to affect its safety or effectiveness.

BANNED SUBSTANCE COMPLIANCE

National Semiconductor certifies that the products and packing materials meet the provisions of the Customer Products Stewardship Specification (CSP-9-111C2) and the Banned Substances and Materials of Interest Specification (CSP-9-111S2) and contain no "Banned Substances" as defined in CSP-9-111S2.



National Semiconductor
Americas Customer
Support Center
 Email: new.feedback@nsc.com
 Tel: 1-800-272-9959

www.national.com

National Semiconductor
Europe Customer Support Center
 Fax: +49 (0) 180-530 85 86
 Email: europa.support@nsc.com
 Deutsch Tel: +49 (0) 69 9508 6208
 English Tel: +44 (0) 870 24 0 2171
 Français Tel: +33 (0) 1 41 91 8790

National Semiconductor
Asia Pacific Customer
Support Center
 Email: ap.support@nsc.com

National Semiconductor
Japan Customer Support Center
 Fax: 81-3-5639-7507
 Email: jpn.feedback@nsc.com
 Tel: 81-3-5639-7560

Looking for pricing, stock, or lifecycle information?

Click below to explore more details on WIN SOURCE:

 [View LM2706TLX/NOPB on WIN SOURCE](#)

 [Texas Instruments](#) Information

Optimize Your Supply Chain with WIN SOURCE Solutions

-  Global Sourcing Solution
-  Obsolete Management
-  Cost Control Management
-  Shortage Management
-  Alternative Solution
-  Excess Inventory Management