



THE DATASHEET OF OPA363IDBVR



OPAx363, OPAx364 1.8-V, 7-MHz, 90-dB CMRR, Single-Supply, Rail-to-Rail I/O Operational Amplifier

1 Features

- 1.8-V Operation
- *MicroSIZE* Packages
- Bandwidth: 7 MHz
- CMRR: 90 dB (Typical)
- Slew Rate: 5 V/ μ s
- Low Offset: 500 μ V (Maximum)
- Quiescent Current: 750 μ A/Channel (Maximum)
- Shutdown Mode: Less Than 1 μ A/Channel

2 Applications

- Signal Conditioning
- Data Acquisition
- Process Control
- Active Filters
- Test Equipment

3 Description

The OPA363 and OPA364 families are high-performance, CMOS operational amplifiers optimized for very low voltage, single-supply operation. These miniature, low-cost amplifiers are designed to operate on single supplies from 1.8 V (± 0.9 V) to 5.5 V (± 2.75 V). Applications include sensor amplification and signal conditioning in battery-powered systems.

The OPA363 and OPA364 families offer excellent CMRR without the crossover associated with traditional complimentary input stages. This feature results in excellent performance for driving analog-to-digital (A/D) converters without degradation of differential linearity and THD. The input common-mode range includes both the negative and positive supplies. The output voltage swing is within 10 mV of the rails.

The OPA363 family includes a shutdown mode. Under logic control, the amplifiers can be switched from normal operation to a standby current that is less than 1 μ A.

The single version is available in the *MicroSize* 5-pin SOT-23 (6-pin SOT-23 for shutdown) and 8-pin SOIC. The dual version is available in 8-pin VSSOP, 10-pin VSSOP, 16-pin UQFN, and 8-pin SOIC packages. Quad packages are available in 14-pin TSSOP and 14-pin SOIC packages. All versions are specified for operation from -40°C to $+125^{\circ}\text{C}$.

Device Information⁽¹⁾

PART NUMBER	PACKAGE	BODY SIZE (NOM)
OPA363	SOT-23 (6)	2.60 mm \times 1.60 mm
	SOIC (8)	4.90 mm \times 3.91 mm
OPA364	SOT-23 (5)	2.60 mm \times 1.60 mm
	SOIC (8)	4.90 mm \times 3.91 mm
OPA2363	VSSOP (10)	3.00 mm \times 3.00 mm
	UQFN (16)	2.60 mm \times 1.80 mm
OPA2364	SOIC (8)	4.90 mm \times 3.91 mm
	VSSOP (8)	3.00 mm \times 3.00 mm
OPA4364	SOIC (14)	8.65 mm \times 3.91 mm
	TSSOP (14)	5.00 mm \times 4.40 mm

(1) For all available packages, see the orderable addendum at the end of the data sheet.

Single-Supply Microphone Preamplifier

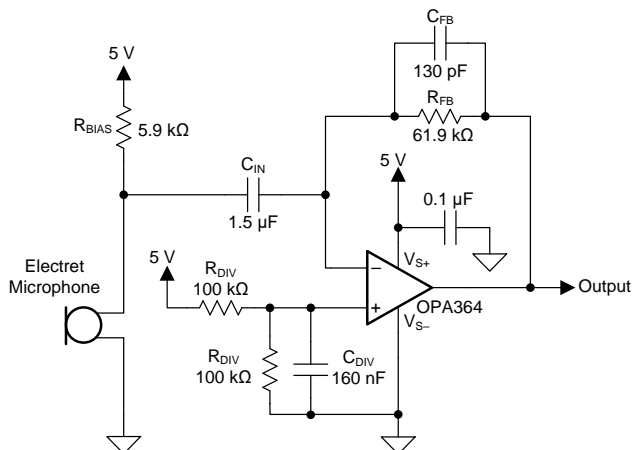

Copyright © 2017, Texas Instruments Incorporated



Table of Contents

1	Features	1	8.2	Functional Block Diagram	17
2	Applications	1	8.3	Feature Description	18
3	Description	1	8.4	Device Functional Modes	19
4	Revision History	2	9	Application and Implementation	20
5	Device Comparison Table	4	9.1	Application Information	20
5.1	Device Comparison Table	4	9.2	Typical Application	23
6	Pin Configuration and Functions	4	10	Power Supply Recommendations	26
7	Specifications	8	11	Layout	26
7.1	Absolute Maximum Ratings	8	11.1	Layout Guidelines	26
7.2	ESD Ratings	8	11.2	Layout Example	26
7.3	Recommended Operating Conditions	8	12	Device and Documentation Support	28
7.4	Thermal Information: OPA363	9	12.1	Device Support	28
7.5	Thermal Information: OPA364	9	12.2	Documentation Support	29
7.6	Thermal Information: OPA2363	10	12.3	Related Links	29
7.7	Thermal Information: OPA2364	10	12.4	Receiving Notification of Documentation Updates	29
7.8	Thermal Information: OPA4364	10	12.5	Community Resource	29
7.9	Electrical Characteristics	11	12.6	Trademarks	29
7.10	Typical Characteristics	13	12.7	Electrostatic Discharge Caution	29
8	Detailed Description	17	12.8	Glossary	30
8.1	Overview	17	13	Mechanical, Packaging, and Orderable Information	30

4 Revision History

NOTE: Page numbers for previous revisions may differ from page numbers in the current version.

Changes from Revision E (January 2018) to Revision F	Page
• Changed OPA363 SOT-23 (5) to SOT-23 (6) in <i>Device Information</i> table	1
• Added OPA363 SOIC (8) package to <i>Device Information</i> table	1
• Changed OPA364 SOT-23 (6) to SOT-23 (5) in <i>Device Information</i> table	1
• Deleted OPA2364 VSSOP (10) and UQFN (16) packages from <i>Device Information table</i>	1
• Deleted OPA2363 SOIC (8) and VSSOP (8) packages from <i>Device Information table</i>	1

Changes from Revision D (September 2016) to Revision E	Page
• Changed OPA36x and OPA236x part numbers to OPA364 and OPA2363 in <i>Device Information</i> table	1
• Added OPA2364 device to <i>Device Information</i> table	1
• Corrected formatting of pinout drawings in <i>Pin Configuration and Functions</i> section	4
• Corrected formatting of pinout tables in <i>Pin Configuration and Functions</i> section	4
• Added a minimum value of 0 V to supply voltage parameter in <i>Absolute Maximum Ratings</i> table	8
• Added "([V+] – [V–])" to supply voltage parameter in <i>Absolute Maximum Ratings</i> table	8
• Deleted operating temperature range from <i>Absolute Maximum Ratings</i> table	8
• Added the word "temperature" to junction and storage temperature ranges in <i>Absolute Maximum Ratings</i> table	8
• Added "([V+] – [V–])" to supply voltage parameter in <i>Recommended Operating Conditions</i> table	8
• Changed output voltage swing parameter units from V to mV	11
• Deleted temperature range section of <i>Electrical Characteristics</i> table	11
• Changed PSRR test condition from $V_{CM} = 0$ to $V_{CM} = (V-)$ in <i>Electrical Characteristics</i> table	11
• Deleted <i>Buffered Reference Voltage</i> subsection in <i>Application Information</i> section	20
• Changed Figure 33	26
• Added Figure 34	27

- Changed "IC" to "device" throughout data sheet..... [28](#)

Changes from Revision C (May 2013) to Revision D
Page

- Added *ESD Ratings* table, *Feature Description* section, *Device Functional Modes*, *Application and Implementation* section, *Power Supply Recommendations* section, *Layout* section, *Device and Documentation Support* section, and *Mechanical, Packaging, and Orderable Information* section [1](#)
- Deleted *Package and Ordering Information* section, see POA at the end of the datasheet..... [1](#)

Changes from Revision B (February 2003) to Revision C
Page

- Converted data sheet to current format..... [1](#)
- Added RSV package (UQFN-16) to data sheet [1](#)
- Added text to last bullet of *Layout Guidelines* section..... [26](#)

5 Device Comparison Table

5.1 Device Comparison Table

	OPA363	OPA364	OPA2363	OPA2364	OPA4364
SOT-23-5		X			
SOT-23-6 (shutdown)	X				
MSOP-8				X	
MSOP-10			X		
SO-8	X	X		X	
TSSOP-14					X
SO-14					X
UQFN-16			X		

6 Pin Configuration and Functions

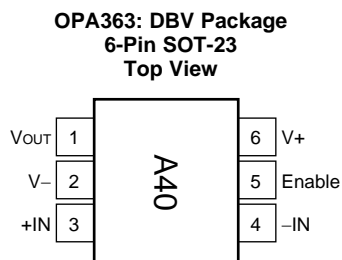

(1) Orient according to marking.

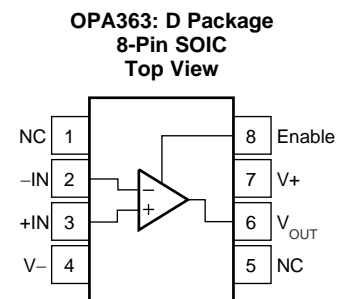

NC- no internal connection

Pin Functions: OPA363

NAME	PIN		I/O	DESCRIPTION
	SOIC	SOT-23		
Enable	8	5	I	Enable
-IN	2	4	I	Negative (inverting) input
+IN	3	3	I	Positive (noninverting) input
NC	1, 5	—	—	No internal connection (can be left floating)
V _{OUT}	6	1	O	Output
V-	4	2	—	Negative (lowest) power supply
V+	7	6	—	Positive (highest) power supply

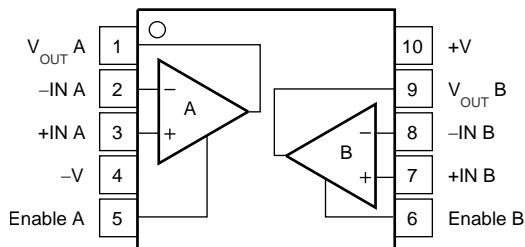
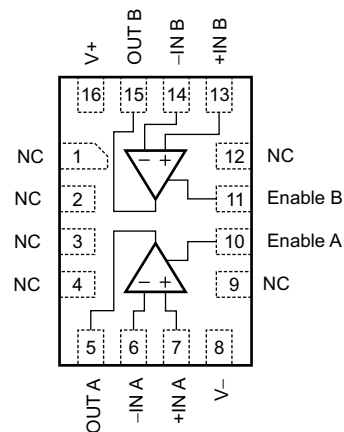
**OPA2363: DGS Package
10-Pin MSOP
Top View**

**OPA2363: RSV Package
16-Pin UQFN
Top View**

NC- no internal connection

Pin Functions: OPA2363

NAME	PIN		I/O	DESCRIPTION
	MSOP	UQFN		
Enable A	5	10	I	Enable A amplifier
Enable B	6	11	I	Enable B amplifier
-IN A	2	6	I	Inverting input, channel A
+IN A	3	7	I	Noninverting input, channel A
-IN B	8	14	I	Inverting input, channel B
+IN B	7	13	I	Noninverting input, channel B
NC	—	1, 2, 3, 4, 9, 12	—	No internal connection (can be left floating)
OUT A	—	5	O	Output, channel A
OUT B	—	15	O	Output, channel B
V _{OUT A}	1	—	O	Output, channel A
V _{OUT B}	9	—	O	Output, channel B
-V, V-	4	8	—	Negative (lowest) power supply
+V, V+	10	16	—	Positive (highest) power supply

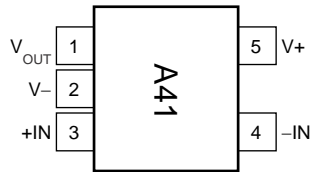
**OPA364: DBV Package
5-Pin SOT-23
Top View**



(1) Orient according to marking.

**OPA364: D Package
8-Pin SOIC
Top View**

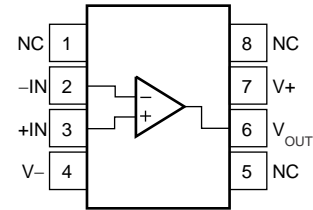

NC - no internal connection

Pin Functions: OPA364

NAME	PIN		I/O	DESCRIPTION
	SOIC	SOT-23		
-IN	2	4	I	Negative (inverting) input
+IN	3	3	I	Positive (noninverting) input
NC	1, 5, 8	—	—	No internal connection (can be left floating)
V _{OUT}	6	1	O	Output
V-	4	2	—	Negative (lowest) power supply
V+	7	5	—	Positive (highest) power supply

**OPA2364: DGK and D Packages
8-Pin MSOP and SOIC
Top View**

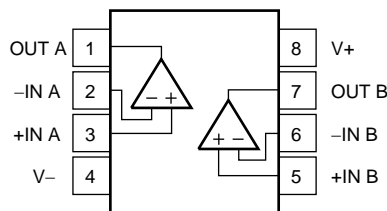

Pin Functions: OPA2364

NAME	PIN		I/O	DESCRIPTION
	NO.			
-IN A	2		I	Inverting input, channel A
+IN A	3		I	Noninverting input, channel A
-IN B	6		I	Inverting input, channel B
+IN B	5		I	Noninverting input, channel B
OUT A	1		O	Output, channel A
OUT B	7		O	Output, channel B
V-	4		—	Negative (lowest) power supply
V+	8		—	Positive (highest) power supply

**OPA4364: D and PW Packages
14-Pin SOIC and TSSOP
Top View**



NC- no internal connection.

Pin Functions: OPA4364

PIN		I/O	DESCRIPTION
NAME	NO.		
-IN A	2	I	Inverting input, channel A
+IN A	3	I	Noninverting input, channel A
-IN B	6	I	Inverting input, channel B
+IN B	5	I	Noninverting input, channel B
-IN C	9	I	Inverting input, channel C
+IN C	10	I	Noninverting input, channel C
-IN D	13	I	Inverting input, channel D
+IN D	12	I	Noninverting input, channel D
V _{OUT} A	1	O	Output, channel A
V _{OUT} B	7	O	Output, channel B
V _{OUT} C	8	O	Output, channel C
V _{OUT} D	14	O	Output, channel D
V-	11	—	Negative (lowest) power supply
V+	4	—	Positive (highest) power supply

7 Specifications

7.1 Absolute Maximum Ratings

 over operating free-air temperature range (unless otherwise noted)⁽¹⁾

		MIN	MAX	UNIT
Voltage	Supply ([V+] – [V–])	0	5.5	V
	Signal input pin ⁽²⁾	–0.5	(V+) + 0.5	
Current	Signal input pin ⁽²⁾	–10	10	mA
	Output short-circuit ⁽³⁾	Continuous		mA
Junction temperature, T _J			150	°C
Storage temperature, T _{stg}		–65	150	

- (1) Stresses beyond those listed under *Absolute Maximum Ratings* may cause permanent damage to the device. These are stress ratings only, which do not imply functional operation of the device at these or any other conditions beyond those indicated under *Recommended Operating Conditions*. Exposure to absolute-maximum-rated conditions for extended periods may affect device reliability.
- (2) Input terminals are diode-clamped to the power-supply rails. Input signals that can swing more than 0.5 V beyond the supply rails must be current limited to 10 mA or less.
- (3) Short-circuit to ground, one amplifier per package.

7.2 ESD Ratings

		VALUE	UNIT
V _(ESD) Electrostatic discharge	Human-body model (HBM), per ANSI/ESDA/JEDEC JS-001 ⁽¹⁾	±2000	V
	Charged-device model (CDM), per JEDEC specification JESD22-C101 ⁽²⁾	±750	

- (1) JEDEC document JEP155 states that 500-V HBM allows safe manufacturing with a standard ESD control process.
- (2) JEDEC document JEP157 states that 250-V CDM allows safe manufacturing with a standard ESD control process.

7.3 Recommended Operating Conditions

over operating free-air temperature range (unless otherwise noted)

		MIN	NOM	MAX	UNIT
	Supply voltage ([V+] – [V–])	1.8		5.5	V
T _A	Operating temperature	–40		125	°C

7.4 Thermal Information: OPA363

THERMAL METRIC ⁽¹⁾		OPA363	
		DBV (SOT-23)	UNIT
		5 PINS	
$R_{\theta JA}$	Junction-to-ambient thermal resistance	211.4	°C/W
$R_{\theta JC(top)}$	Junction-to-case (top) thermal resistance	137	°C/W
$R_{\theta JB}$	Junction-to-board thermal resistance	39.8	°C/W
Ψ_{JT}	Junction-to-top characterization parameter	20.6	°C/W
Ψ_{JB}	Junction-to-board characterization parameter	38.9	°C/W
$R_{\theta JC(bot)}$	Junction-to-case (bottom) thermal resistance	—	°C/W

(1) For more information about traditional and new thermal metrics, see the [Semiconductor and IC Package Thermal Metrics](#) application report.

7.5 Thermal Information: OPA364

THERMAL METRIC ⁽¹⁾		OPA364		UNIT
		DBV (SOT-23)	D (SOIC)	
		6 PINS	8 PINS	
$R_{\theta JA}$	Junction-to-ambient thermal resistance	182.7	125.3	°C/W
$R_{\theta JC(top)}$	Junction-to-case (top) thermal resistance	130.7	73.7	°C/W
$R_{\theta JB}$	Junction-to-board thermal resistance	34.1	65.7	°C/W
Ψ_{JT}	Junction-to-top characterization parameter	24.8	25.4	°C/W
Ψ_{JB}	Junction-to-board characterization parameter	33.5	65.2	°C/W
$R_{\theta JC(bot)}$	Junction-to-case (bottom) thermal resistance	—	—	°C/W

(1) For more information about traditional and new thermal metrics, see the [Semiconductor and IC Package Thermal Metrics](#) application report.

7.6 Thermal Information: OPA2363

THERMAL METRIC ⁽¹⁾	OPA2363				UNIT
	D (SOIC)	DGK (VSSOP)	DGS (VSSOP)	UQFN (RSV)	
	8 PINS	8 PINS	10 PINS	16 PINS	
$R_{\theta JA}$ Junction-to-ambient thermal resistance	125.3	171.8	166.4	112.4	°C/W
$R_{\theta JC(top)}$ Junction-to-case (top) thermal resistance	73.7	63.2	55.9	44	°C/W
$R_{\theta JB}$ Junction-to-board thermal resistance	65.7	92.4	86.6	41.2	°C/W
Ψ_{JT} Junction-to-top characterization parameter	25.4	9.5	6.8	0.8	°C/W
Ψ_{JB} Junction-to-board characterization parameter	65.2	91	85.2	41.2	°C/W
$R_{\theta JC(bottom)}$ Junction-to-case (bottom) thermal resistance	—	—	—	—	°C/W

(1) For more information about traditional and new thermal metrics, see the [Semiconductor and IC Package Thermal Metrics](#) application report.

7.7 Thermal Information: OPA2364

THERMAL METRIC ⁽¹⁾	OPA2364				UNIT
	D (SOIC)	DGK (VSSOP)	DGS (VSSOP)	UQFN (RSV)	
	8 PINS	8 PINS	10 PINS	16 PINS	
$R_{\theta JA}$ Junction-to-ambient thermal resistance	125.3	171.8	166.4	112.4	°C/W
$R_{\theta JC(top)}$ Junction-to-case (top) thermal resistance	73.7	63.2	55.9	44	°C/W
$R_{\theta JB}$ Junction-to-board thermal resistance	65.7	92.4	86.6	41.2	°C/W
Ψ_{JT} Junction-to-top characterization parameter	25.4	9.5	6.8	0.8	°C/W
Ψ_{JB} Junction-to-board characterization parameter	65.2	91	85.2	41.2	°C/W
$R_{\theta JC(bottom)}$ Junction-to-case (bottom) thermal resistance	—	—	—	—	°C/W

(1) For more information about traditional and new thermal metrics, see the [Semiconductor and IC Package Thermal Metrics](#) application report.

7.8 Thermal Information: OPA4364

THERMAL METRIC ⁽¹⁾	OPA4364		UNIT
	D (SOIC)	PW (TSSOP)	
	14 PINS	14 PINS	
$R_{\theta JA}$ Junction-to-ambient thermal resistance	82.6	107.5	°C/W
$R_{\theta JC(top)}$ Junction-to-case (top) thermal resistance	41.1	31.9	°C/W
$R_{\theta JB}$ Junction-to-board thermal resistance	37.1	50.6	°C/W
Ψ_{JT} Junction-to-top characterization parameter	9.4	1.9	°C/W
Ψ_{JB} Junction-to-board characterization parameter	36.8	49.9	°C/W
$R_{\theta JC(bottom)}$ Junction-to-case (bottom) thermal resistance	—	—	°C/W

(1) For more information about traditional and new thermal metrics, see the [Semiconductor and IC Package Thermal Metrics](#) application report.

7.9 Electrical Characteristics

at $T_A = 25^\circ\text{C}$, $R_L = 10\text{ k}\Omega$ connected to $V_S / 2$, $V_{OUT} = V_S / 2$, and $V_{CM} = V_S / 2$, $V_S = 1.8\text{ V}$ to 5.5 V , (unless otherwise noted)

PARAMETER		TEST CONDITIONS	MIN	TYP	MAX	UNIT
OFFSET VOLTAGE						
V_{OS}	Input offset voltage	$V_S = 5\text{ V}$ (OPA363I, OPA364I)			500	μV
		OPA2363I, OPA2364I			900	μV
		OPA363AI, OPA364AI, OPA2363AI, OPA2364AI, OPA4364AI		1	2.5	mV
dV_{OS}/dT	Drift	$T_A = -40^\circ\text{C}$ to $+125^\circ\text{C}$		3		$\mu\text{V}/^\circ\text{C}$
PSRR	Input offset voltage vs power supply	$V_S = 1.8\text{ V}$ to 5.5 V $V_{CM} = (V_-)$ $T_A = -40^\circ\text{C}$ to $+125^\circ\text{C}$		80	330	$\mu\text{V}/\text{V}$
	Channel separation, DC			1		$\mu\text{V}/\text{V}$
INPUT BIAS CURRENT						
I_B	Input bias current	$T_A = 25^\circ\text{C}$		± 1	± 10	pA
		$T_A = -40^\circ\text{C}$ to $+125^\circ\text{C}$		See Typical Characteristics		
I_{OS}	Input offset current			± 1	± 10	pA
NOISE						
e_n	Input voltage noise,	$f = 0.1\text{ Hz}$ to 10 Hz		10		μV_{PP}
e_n	Input voltage noise density	$f = 10\text{ kHz}$		17		$\text{nV}/\sqrt{\text{Hz}}$
i_n	Input current noise density	$f = 10\text{ kHz}$		0.6		$\text{fA}/\sqrt{\text{Hz}}$
INPUT VOLTAGE RANGE						
V_{CM}	Common-mode voltage range		$(V_-) - 0.1$		$(V_+) + 0.1$	V
CMRR	Common-mode rejection ratio	$(V_-) - 0.1\text{ V} < V_{CM} < (V_+) + 0.1\text{ V}$ $T_A = -40^\circ\text{C}$ to $+125^\circ\text{C}$	74	90		dB
INPUT CAPACITANCE						
	Differential			2		pF
	Common-mode			3		pF
OPEN-LOOP GAIN						
A_{OL}	Open-loop voltage gain	$R_L = 10\text{ k}\Omega$ $100\text{ mV} < V_O < (V_+) - 100\text{ mV}$	$T_A = 25^\circ\text{C}$	94	100	dB
			$T_A = 25^\circ\text{C}$ (OPA4364)	90		dB
		$R_L = 10\text{ k}\Omega$ $100\text{ mV} < V_O < (V_+) - 100\text{ mV}$	$V_S = 1.8\text{ V}$ to 5.5 V $T_A = -40^\circ\text{C}$ to $+125^\circ\text{C}$	86		dB
FREQUENCY RESPONSE						
GBW	Gain-bandwidth product	$C_L = 100\text{ pF}$		7		MHz
SR	Slew rate	$C_L = 100\text{ pF}$, $G = 1$		5		$\text{V}/\mu\text{s}$
t_S	Settling time	0.1%, $C_L = 100\text{ pF}$, $V_S = 5\text{ V}$, 4-V step, $G = 1$		1		μs
		0.01%, $C_L = 100\text{ pF}$, $V_S = 5\text{ V}$, 4-V step, $G = 1$		1.5		μs
	Overload recovery time	$C_L = 100\text{ pF}$ $V_{IN} \times \text{Gain} > V_S$		0.8		μs
THD+N	Total harmonic distortion + noise	$C_L = 100\text{ pF}$, $V_S = 5\text{ V}$, $G = 1$, $f = 20\text{ Hz}$ to 20 kHz		0.002%		
OUTPUT						
	Voltage output swing	$R_L = 10\text{ k}\Omega$, $T_A = 25^\circ\text{C}$		10	20	mV
		$R_L = 10\text{ k}\Omega$ $T_A = -40^\circ\text{C}$ to $+125^\circ\text{C}$			20	mV
I_{SC}	Short-circuit current		See Typical Characteristics			
C_{LOAD}	Capacitive load drive		See Typical Characteristics			
SHUTDOWN (OPA363)						
t_{OFF}	Turnoff time			1		μs
t_{ON}	Turnon time ⁽¹⁾			20		μs
V_L	Logic low threshold	Shutdown			$(V_-) + 0.8$	V
V_H	Logic high threshold	Amplifier is active	0.75 (V+)		5.5	V
$I_{Q(sd)}$	Quiescent current at shutdown (per amplifier)				0.9	μA

(1) Part is considered enabled when input offset voltage returns to specified range.

Electrical Characteristics (continued)

 at $T_A = 25^\circ\text{C}$, $R_L = 10\text{ k}\Omega$ connected to $V_S / 2$, $V_{OUT} = V_S / 2$, and $V_{CM} = V_S / 2$, $V_S = 1.8\text{ V}$ to 5.5 V , (unless otherwise noted)

PARAMETER		TEST CONDITIONS	MIN	TYP	MAX	UNIT
POWER SUPPLY						
V_S	Specified voltage range		1.8		5.5	V
I_Q	Quiescent current (per amplifier)	$V_S = 1.8\text{ V}$ $T_A = -40^\circ\text{C}$ to $+125^\circ\text{C}$		650	750	μA
		$V_S = 3.6\text{ V}$ $T_A = -40^\circ\text{C}$ to $+125^\circ\text{C}$		850	1000	μA
		$V_S = 5.5\text{ V}$ $T_A = -40^\circ\text{C}$ to $+125^\circ\text{C}$		1.1	1.4	mA

7.10 Typical Characteristics

at $T_A = 25^\circ\text{C}$, $R_L = 10\text{ k}\Omega$ connected to $V_S / 2$, $V_{OUT} = V_S / 2$, and $V_{CM} = V_S / 2$, (unless otherwise noted)



Figure 1. Open-Loop Gain and Phase vs Frequency



Figure 2. Common-Mode Rejection Ratio vs Frequency

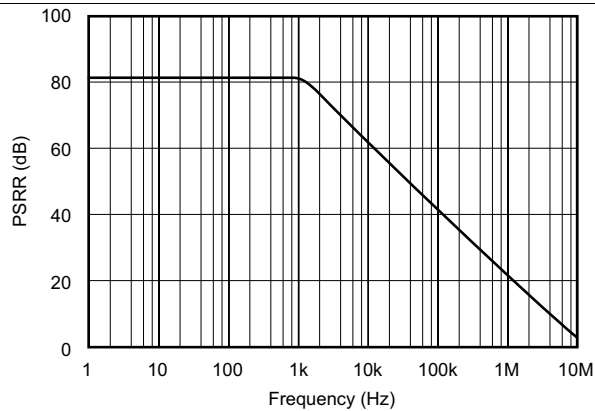

Figure 3. Power-Supply Rejection Ratio vs Frequency

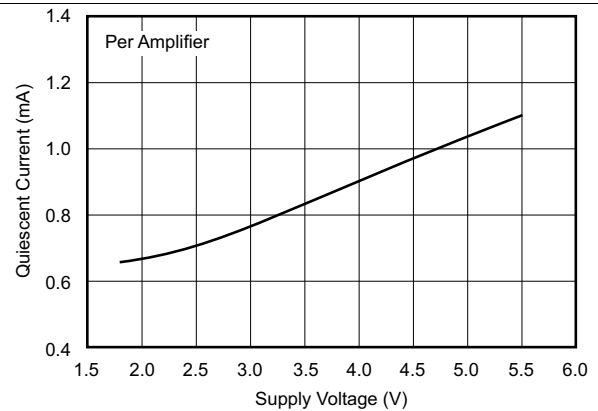

Figure 4. Quiescent Current vs Supply Voltage

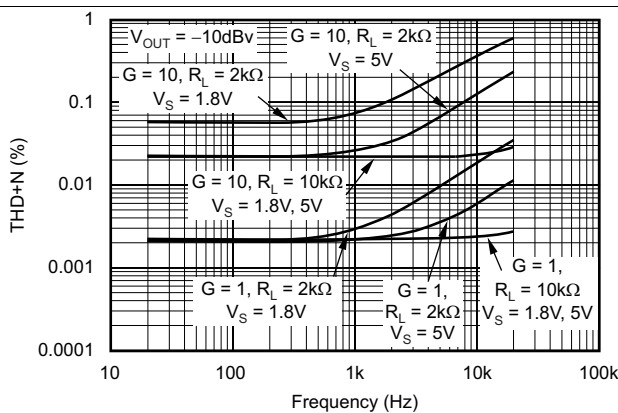

Figure 5. Total Harmonic Distortion + Noise Ratio vs Frequency

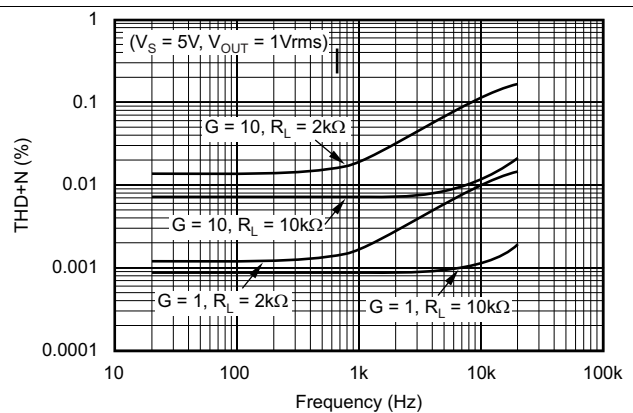

Figure 6. Total Harmonic Distortion + Noise Ratio vs Frequency

Typical Characteristics (continued)

at $T_A = 25^\circ\text{C}$, $R_L = 10\text{ k}\Omega$ connected to $V_S / 2$, $V_{OUT} = V_S / 2$, and $V_{CM} = V_S / 2$, (unless otherwise noted)

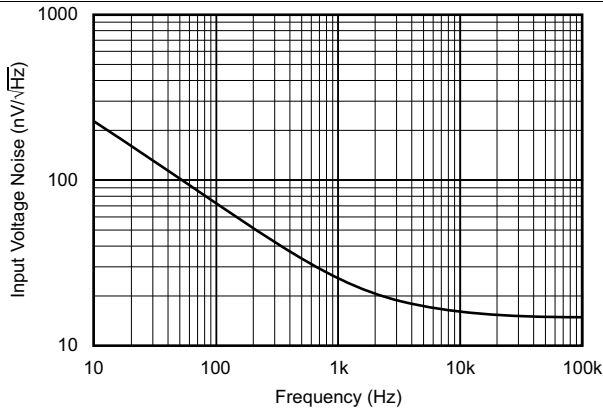

Figure 7. Input Voltage Noise Spectral Density vs Frequency



Figure 8. Short-Circuit Current vs Supply Voltage

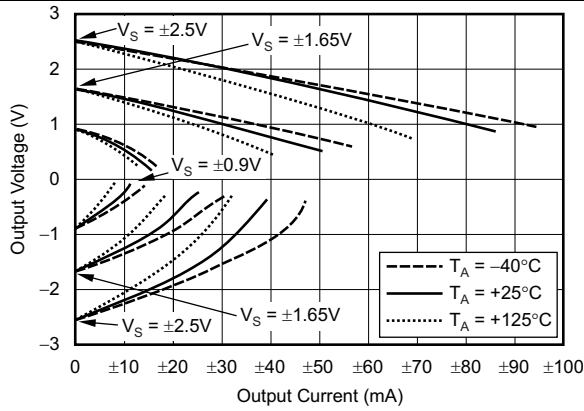

Figure 9. Output Voltage Swing vs Output Current

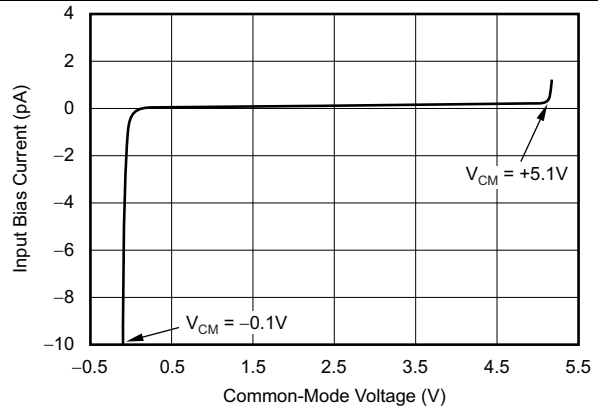

Figure 10. Input Bias Current vs Input Common-Mode Voltage

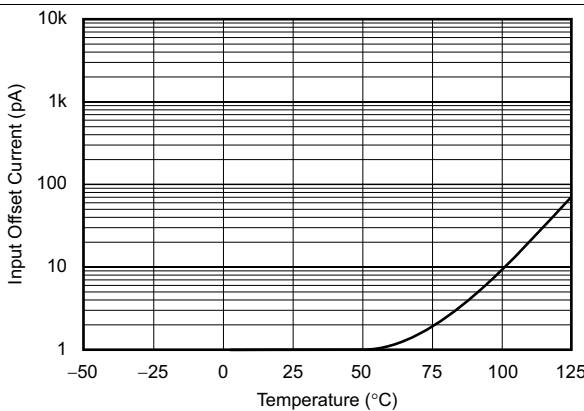

Figure 11. Input Offset Current vs Temperature



Figure 12. Input Bias Current vs Temperature

Typical Characteristics (continued)

at $T_A = 25^\circ\text{C}$, $R_L = 10\text{ k}\Omega$ connected to $V_S / 2$, $V_{OUT} = V_S / 2$, and $V_{CM} = V_S / 2$, (unless otherwise noted)



Figure 13. Small-Signal Overshoot vs Load Capacitance



Figure 14. Settling Time vs Closed-Loop Gain



Figure 15. Offset Drift Distribution



Figure 16. Offset Voltage Production Distribution

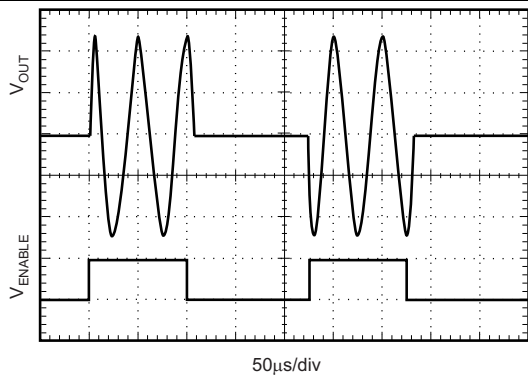

Figure 17. Output Enable Characteristic ($V_S = 5\text{ V}$, $V_{OUT} = 20\text{-kHz Sinusoid}$)

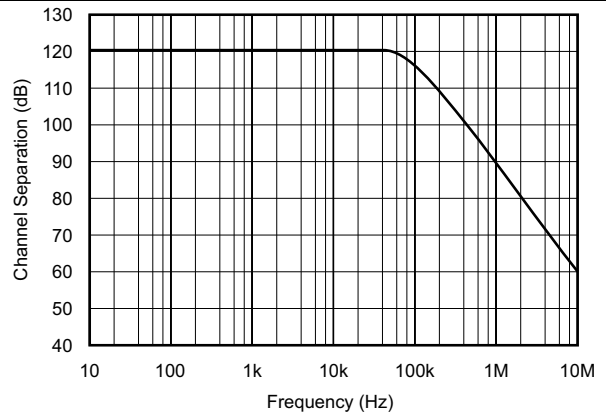

Figure 18. Channel Separation vs Frequency

Typical Characteristics (continued)

at $T_A = 25^\circ\text{C}$, $R_L = 10\text{ k}\Omega$ connected to $V_S / 2$, $V_{OUT} = V_S / 2$, and $V_{CM} = V_S / 2$, (unless otherwise noted)



8 Detailed Description

8.1 Overview

The OPA363 and OPA364 series op amps are rail-to-rail operational amplifiers with excellent CMRR, low noise, low offset, and wide bandwidth on supply voltages as low as ± 0.9 V. The OPA363 features an additional pin for a shutdown and enable function. These families do not exhibit phase reversal and are unity-gain stable. Specified over the industrial temperature range of -40°C to $+125^{\circ}\text{C}$, the OPA363 and OPA364 families offer precision performance for a wide range of applications.

8.2 Functional Block Diagram



Copyright © 2017, Texas Instruments Incorporated

8.3 Feature Description

8.3.1 Rail-to-Rail Input

The OPA363 and OPA364 feature excellent rail-to-rail operation, with supply voltages as low as ± 0.9 V. The input common-mode voltage range of the OPA363 and OPA364 family extends 100 mV beyond supply rails. The unique input topology of the OPA363 and OPA364 eliminates the input offset transition region typical of most rail-to-rail, complementary stage operational amplifiers, allowing the OPA363 and OPA364 to provide superior common-mode performance over the entire common-mode input range, as seen in [Figure 21](#). This feature prevents degradation of the differential linearity error and THD when driving A/D converters. A simplified schematic of the OPA363 and OPA364 is shown in the [Functional Block Diagram](#).



Figure 21. OPA363 and OPA364 Have Linear Offset Over Entire Common-Mode Range

8.3.2 Operating Voltage

The OPA363 and OPA364 series op amp parameters are fully specified from 1.8 V to 5.5 V. Single 0.1- μ F bypass capacitors must be placed across supply pins and as close to the part as possible. Supply voltages higher than 5.5 V (absolute maximum) may cause permanent damage to the amplifier. Many specifications apply from -40°C to $+125^{\circ}\text{C}$. Parameters that vary significantly with operating voltages or temperature are shown in the [Typical Characteristics](#).

8.3.3 Capacitive Load

The OPAx363 and OPAx364 series op amps can drive a wide range of capacitive loads. However, all op amps under certain conditions may become unstable. Op amp configuration, gain, and load value are a few of the factors to consider when determining stability. An op amp in unity-gain configuration is the most susceptible to the effects of capacitive load. The capacitive load reacts with the output resistance of the op amp to create a pole in the small-signal response, which degrades the phase margin.

In unity gain, the OPAx363 and OPAx364 series op amps perform well with a pure capacitive load up to approximately 1000 pF. The equivalent series resistance (ESR) of the loading capacitor may be sufficient to allow the OPA363 and OPA364 to directly drive very large capacitive loads (greater than 1 μ F). Increasing gain enhances the ability of the amplifier to drive more capacitance; see [Figure 13](#).

One method of improving capacitive load drive in the unity-gain configuration is to insert a 10- Ω to 20- Ω resistor in series with the output, as shown in [Figure 22](#). This resistor significantly reduces ringing with large capacitive loads. However, if there is a resistive load in parallel with the capacitive load, the load creates a voltage divider, introduces a DC error at the output, and slightly reduces output swing. This error may be insignificant. For example, with $R_L = 10$ k Ω and $R_S = 20$ Ω , there is an approximate 0.2% error at the output.

Feature Description (continued)

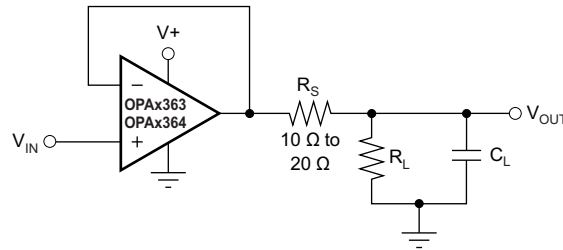

Copyright © 2017, Texas Instruments Incorporated

Figure 22. Improving Capacitive Load Drive

8.3.4 Input and ESD Protection

All OPAx363 and OPAx364 pins are static-protected with internal ESD protection diodes tied to the supplies. These diodes provide overdrive protection if the current is externally limited to 10 mA, as shown in the [Absolute Maximum Ratings](#) and shown in [Figure 23](#).



Copyright © 2017, Texas Instruments Incorporated

Figure 23. Input Current Protection

8.4 Device Functional Modes

8.4.1 Enable Function

The shutdown (enable) function of the OPAx363 is referenced to the negative supply voltage of the operational amplifier. A logic level HIGH enables the op amp. A valid logic HIGH is defined as voltage greater than 75% of the positive supply applied to the enable pin. The valid logic HIGH signal can be as much as 5.5 V above the negative supply, independent of the positive supply voltage. A valid logic LOW is defined as less than 0.8 V above the negative supply pin. If dual or split power supplies are used, take care to ensure that logic input signals are properly referred to the negative supply voltage. This pin must be connected to a valid high or low voltage or driven, not left open-circuit.

The logic input is a high-impedance CMOS input. Dual op amps are provided separate logic inputs. For battery-operated applications, this feature reduces the average current and extend battery life. The enable time is 20 μ s; disable time is 1 μ s. When disabled, the output assumes a high-impedance state. This configuration allows the OPAx363 to operate as a *gated* amplifier, or to have the output multiplexed onto a common analog output bus.

9 Application and Implementation

NOTE

Information in the following applications sections is not part of the TI component specification, and TI does not warrant its accuracy or completeness. TI's customers are responsible for determining suitability of components for their purposes. Customers should validate and test their design implementation to confirm system functionality.

9.1 Application Information

9.1.1 Achieving Output Swing to the Op Amp Negative Rail

Some applications require an accurate output voltage swing from 0 V to a positive full-scale voltage. A good single-supply op amp may be able to swing within a few millivolts of single-supply ground, but as the output is driven toward 0 V, the output stage of the amplifier prevents the output from reaching the negative supply rail of the amplifier.

The output of the OPAx363 or OPAx364 can be made to swing to ground, or slightly below, on a single-supply power source. To do so requires use of another resistor and an additional, more negative power supply than the op amp negative supply. A pull-down resistor may be connected between the output and the additional negative supply to pull the output down below the value that the output would otherwise achieve, as shown in [Figure 24](#).



Copyright © 2017, Texas Instruments Incorporated

Figure 24. OPA363 and OPA364 Swing to Ground

This technique does not work with all op amps. The output stage of the OPAx363 and OPA3x64 allows the output voltage to be pulled below that of most op amps, if approximately 500 μ A is maintained through the output stage. To calculate the appropriate value load resistor and negative supply, $R_L = -V / 500 \mu\text{A}$. The OPAx363 and OPAx364 are characterized to perform well under the described conditions, maintaining excellent accuracy down to 0 V and as low as -10 mV. Limiting and nonlinearity occur below -10 mV, with linearity returning as the output is again driven above -10 mV.

9.1.2 Directly Driving the ADS8324 and the MSP430

The OPAx363 and OPAx364 series op amps are optimized for driving medium speed (up to 100-kHz) sampling A/D converters. However, they also offer excellent performance for higher speed converters. The no-crossover input stage of the OPAx363 and OPAx364 directly drive A/D converters without degradation of differential linearity and THD. They provide an effective means of buffering the A/D converter input capacitance and resulting charge injection while providing signal gain. [Figure 25](#) and [Figure 26](#) show the OPAx363 and OPAx364 configured to drive the ADS8324 and the 12-bit A/D converter on the MSP430.

Application Information (continued)

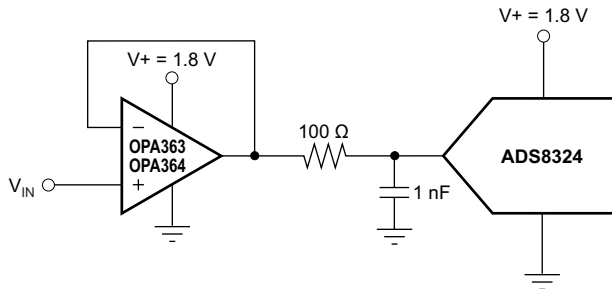

Copyright © 2017, Texas Instruments Incorporated

Figure 25. OPAx363 and OPAx364 Directly Drive the ADS8324

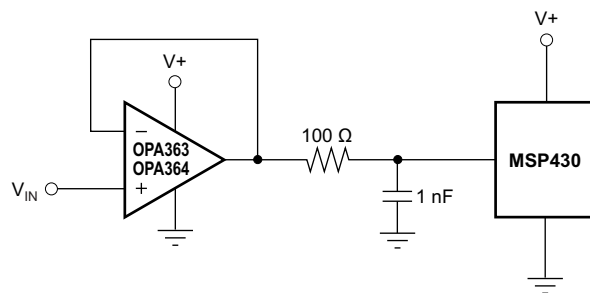

Copyright © 2017, Texas Instruments Incorporated

Figure 26. Driving the 12-Bit A/D Converter on the MSP430

9.1.3 Audio Applications

The OPAx363 and OPAx364 op amp family has linear offset voltage over the entire input common-mode range. Combined with low noise, this feature makes the OPAx363 and OPAx364 suitable for audio applications. Single-supply, 1.8-V operation allows the OPA2363 and OPA2364 to be optimal candidates for dual stereo-headphone drivers and microphone preamplifiers in portable stereo equipment; see Figure 27 and Figure 28.

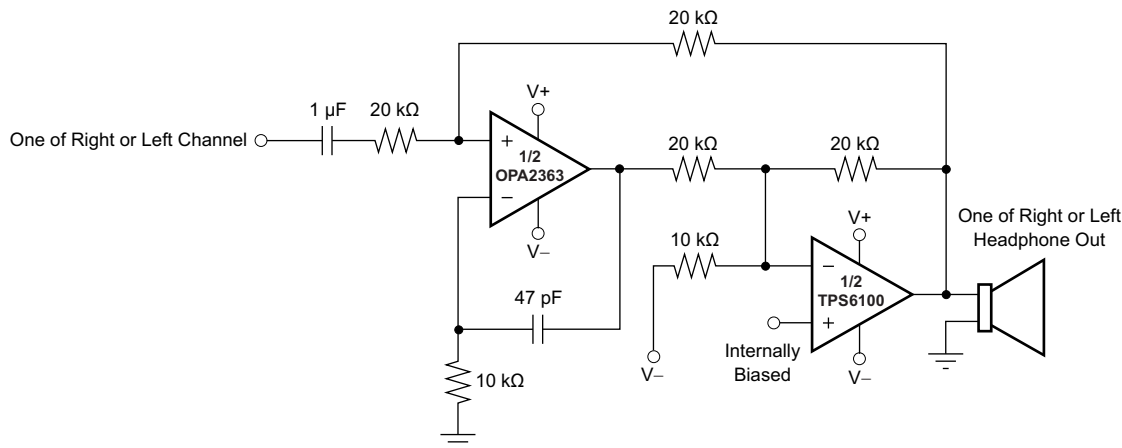

Copyright © 2017, Texas Instruments Incorporated

Figure 27. OPA2363 Configured as Half of a Dual Stereo-Headphone Driver

Application Information (continued)

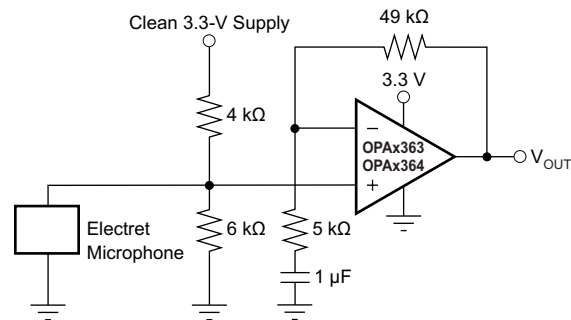

Copyright © 2017, Texas Instruments Incorporated

Figure 28. Microphone Preamplifier

9.1.4 Active Filtering

Low harmonic distortion and noise specifications plus high gain and slew rate make the OPAx363 and OPAx364 optimal candidates for active filtering. [Figure 29](#) shows the OPA2363 configured as a low-distortion, third-order general immittance converter (GIC) filter. [Figure 30](#) shows the implementation of a Sallen-Key, 3-pole, low-pass Bessel filter.

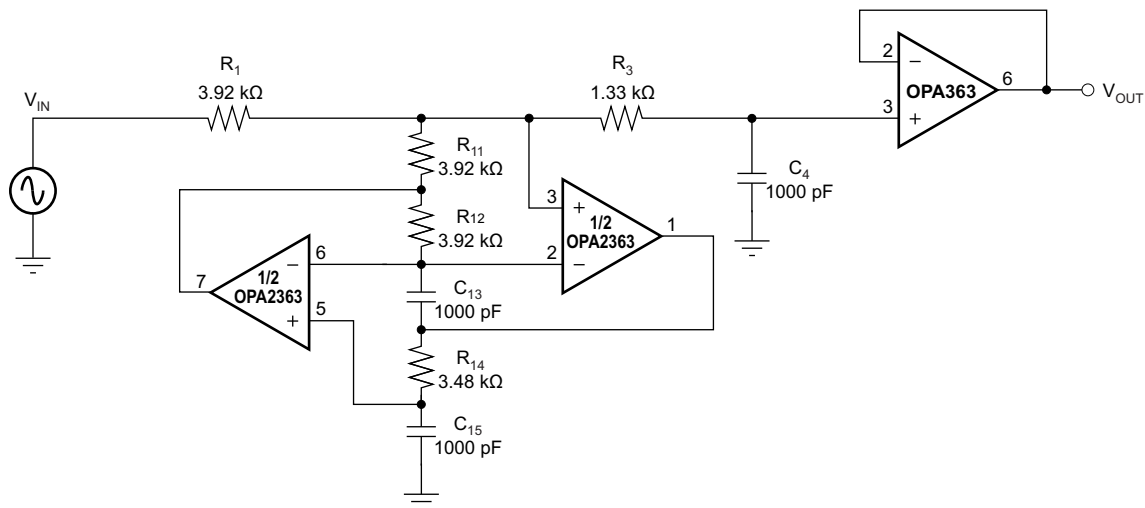

Copyright © 2017, Texas Instruments Incorporated

Figure 29. OPA2363 as a Third-Order, 40-kHz, Low-Pass GIC Filter

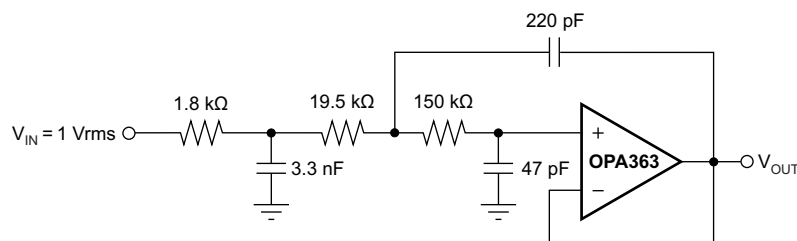

Copyright © 2017, Texas Instruments Incorporated

Figure 30. OPAx363 or OPAx364 Configured as a 3-Pole, 20-kHz, Sallen-Key Filter

9.2 Typical Application

9.2.1 Single-Supply Electret Microphone Preamplifier

Electret microphones are commonly used in portable electronics because of their small size, low cost, and relatively good signal-to-noise ratio (SNR). The small package size and excellent AC performance of the OPA364 make it an excellent choice for preamplifier circuits for electret microphones. The circuit shown in Figure 31 is a single-supply preamplifier circuit for electret microphones.

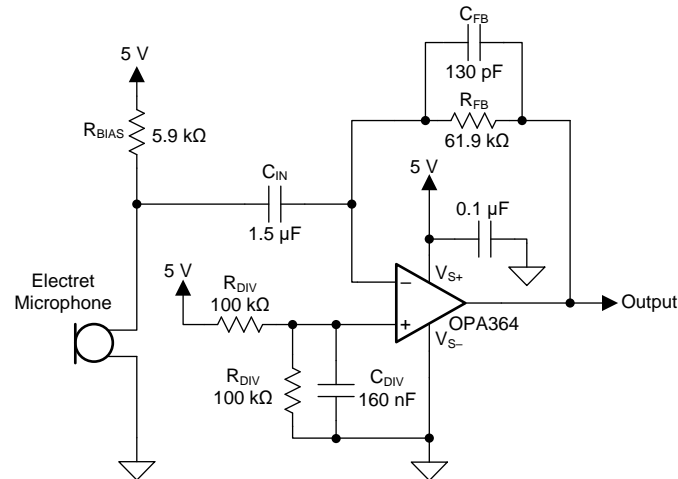

Copyright © 2017, Texas Instruments Incorporated

Figure 31. Preamplifier Circuit for Electret Microphones Using a Single-Supply Voltage

9.2.1.1 Design Requirements

- 5-V single supply
- 1- V_{RMS} output for 100-dB_{SPL} input
- 20-Hz to 20-kHz, –3-dB bandwidth
- Microphone sensitivity: 8 $\mu A/Pa$
- Microphone operating voltage: 2 V to 10 V
- Microphone bias current: 500 μA

9.2.1.2 Detailed Design Procedure

In this circuit, the op amp is configured as a transimpedance amplifier which converts the signal current of the microphone into an output voltage. The gain of the circuit is determined by the feedback resistor R_{FB} , which must be calculated according to the microphone sensitivity. For this design, a microphone output current of 8 μA per Pascal (Pa) of air pressure was chosen. Using this value, the output current for a sound pressure level of 100 dB_{SPL}, or 2 Pa air pressure, is calculated in Equation 1.

$$i_{mic} = \frac{8 \mu A}{1 Pa} \times 2 Pa = 16 \mu A \quad (1)$$

R_{FB} is then calculated from this current to produce 1- V_{RMS} output for a 100-dB_{SPL} input signal in Equation 2.

$$R_{FB} = \frac{V_O}{i_{mic}} = \frac{1 V_{RMS}}{16 \mu A} = 62500 \rightarrow 61.9 k\Omega \quad (2)$$

The feedback capacitor (C_{FB}) is calculated to limit the bandwidth of the amplifier to 20 kHz in Equation 3.

$$C_{FB} = \frac{1}{2 \cdot \pi \cdot R_{FB} \cdot f_H} = \frac{1}{2 \cdot \pi \cdot (61.9 k\Omega) \cdot (20 kHz)} = 128.5 \times 10^{-12} \rightarrow 130 pF \quad (3)$$

Typical Application (continued)

R_{BIAS} is required to divert the microphone signal current through capacitor C_{IN} rather than flowing from the power supply, V_{CC} . Larger values of R_{BIAS} allow for a smaller capacitor to be used for C_{IN} and reduce the overall noise of the circuit. However, the maximum value for R_{BIAS} is limited by the microphone bias current and minimum operating voltage.

The value of R_{BIAS} is calculated in [Equation 4](#).

$$R_{BIAS} = \frac{V_{CC} - V_{MIC}}{I_{BIAS}} = \frac{5\text{ V} - 2\text{ V}}{500\ \mu\text{A}} = 6000 \rightarrow 5.9\ \text{k}\Omega \quad (4)$$

Input capacitor C_{IN} forms a high-pass filter in combination with resistor R_{BIAS} . The filter corner frequency calculation is shown in [Equation 5](#) to place the high-pass corner frequency at 20 Hz.

$$C_{IN} = \frac{1}{2 \cdot \pi \cdot R_{BIAS} \cdot f_L} = \frac{1}{2 \cdot \pi \cdot (5.9\ \text{k}\Omega) \cdot (20\ \text{Hz})} = 1.349 \times 10^{-6} \rightarrow 1.5\ \mu\text{F} \quad (5)$$

The voltage divider network at the op amp noninverting input is used to bias the op amp output to the mid-supply point ($V_{CC} / 2$) to maximize the output voltage range of the circuit. This result is easily achieved by selecting the same value for both resistors in the divider. The absolute value of those resistors is limited by the acceptable power-supply current drawn by the voltage divider. Selecting $25\ \mu\text{A}$ as an acceptable limit of supply current gives a value of $100\ \text{k}\Omega$ for the resistors in the divider, as [Equation 6](#) shows.

$$R_{DIV} = \frac{V_{CC}}{2 \cdot I_{DIV}} = \frac{5\ \text{V}}{2 \cdot 25\ \mu\text{A}} = 100\ \text{k}\Omega \quad (6)$$

Finally, to minimize the additional noise contribution from the voltage divider, a capacitor is placed at the op amp noninverting input. This capacitor forms a low-pass filter with the parallel combination of the voltage divider resistors. Selecting a filter corner frequency of 20 Hz minimizes the noise contribution of the voltage divider inside the amplifier passband; see [Equation 7](#).

$$C_{DIV} = \frac{1}{2 \cdot \pi \cdot \left(\frac{R_{DIV}}{2}\right) \cdot f_L} = \frac{1}{2 \cdot \pi \cdot \left(\frac{100\ \text{k}\Omega}{2}\right) \cdot (20\ \text{Hz})} = 1.592 \times 10^{-7} \rightarrow 160\ \text{nF} \quad (7)$$

9.2.1.3 Application Curve

The transfer function of the microphone preamplifier circuit is shown in [Figure 32](#). The nominal gain of the circuit is 95.82 dB, or 61,800 V per amp of input current. The -3-dB bandwidth limits of the circuit are 17.99 Hz and 19.23 kHz.

Typical Application (continued)

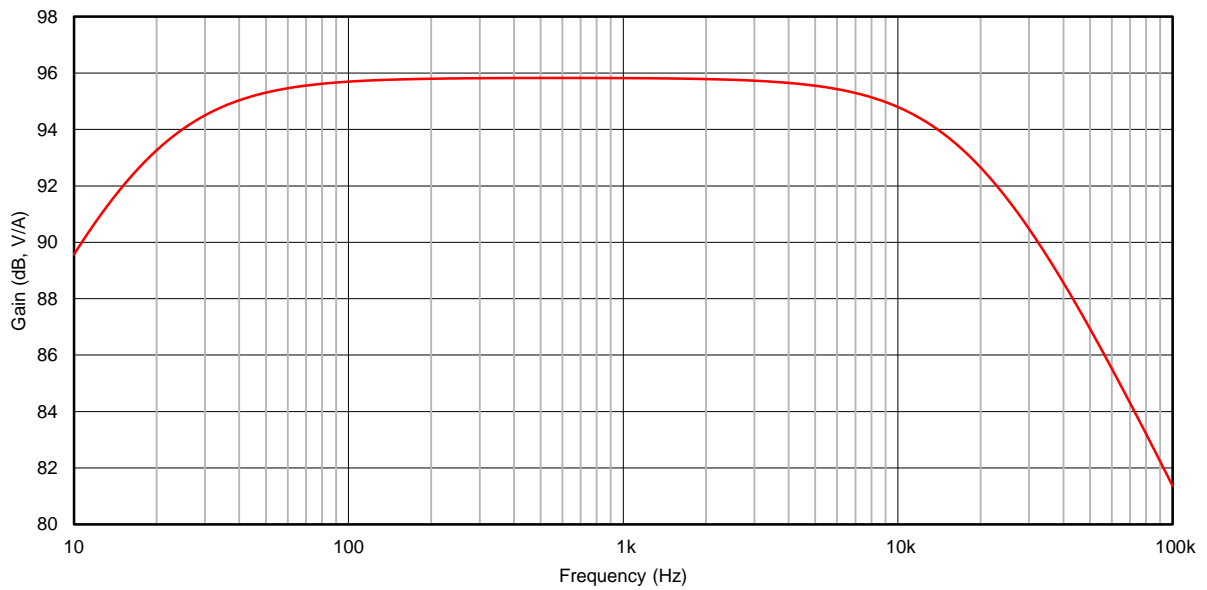

Figure 32. Microphone Preamp Transfer Function

10 Power Supply Recommendations

The OPAx363 and OPAx364 are specified for operation from 2.7 V to 5.5 V (± 1.35 V to ± 2.75 V). Parameters that can exhibit significant variance with regard to operating voltage are presented in the [Electrical Characteristics](#).

11 Layout

11.1 Layout Guidelines

For best operational performance of the device, use good printed-circuit board (PCB) layout practices, including:

- Noise can propagate into analog circuitry through the power pins of the circuit as a whole and of op amp itself. Bypass capacitors reduce the coupled noise by providing low-impedance power sources local to the analog circuitry.
 - Connect low-ESR, 0.1- μ F ceramic bypass capacitors between each supply pin and ground, placed as close to the device as possible. A single bypass capacitor from V+ to ground is applicable for single-supply applications.
- Separate grounding for analog and digital portions of circuitry is one of the simplest and most effective methods of noise suppression. One or more layers on multilayer PCBs are usually devoted to ground planes. A ground plane helps distribute heat and reduces EMI noise pickup. Make sure to physically separate digital and analog grounds, paying attention to the flow of the ground current.
- To reduce parasitic coupling, run the input traces as far away from the supply or output traces as possible. If these traces cannot be kept separate, crossing the sensitive trace perpendicular is much better as opposed to in parallel with the noisy trace.
- Place the external components as close to the device as possible. As shown in [Figure 33](#), keeping R_F and R_G close to the inverting input minimizes parasitic capacitance.
- Keep the length of input traces as short as possible. Always remember that the input traces are the most sensitive part of the circuit.
- Consider a driven, low-impedance guard ring around the critical traces. A guard ring can significantly reduce leakage currents from nearby traces that are at different potentials.
- Cleaning the PCB following board assembly is recommended for best performance.
- Any precision integrated circuit can experience performance shifts resulting from moisture ingress into the plastic package. Following any aqueous PCB cleaning process, baking the PCB assembly is recommended to remove moisture introduced into the device packaging during the cleaning process. A low temperature, post-cleaning bake at 85°C for 30 minutes is sufficient for most circumstances.

11.2 Layout Example



Figure 33. Operational Amplifier Board Layout for Noninverting Configuration

Layout Example (continued)



Figure 34. Layout Example Schematic

12 Device and Documentation Support

12.1 Device Support

12.1.1 Development Support

12.1.1.1 TINA-TI™ (Free Software Download)

TINA™ is a simple, powerful, and easy-to-use circuit simulation program based on a SPICE engine. TINA-TI™ is a free, fully-functional version of the TINA software, preloaded with a library of macro models in addition to a range of both passive and active models. TINA-TI provides all the conventional dc, transient, and frequency domain analysis of SPICE, as well as additional design capabilities.

Available as a [free download](#) from the Analog eLab Design Center, TINA-TI offers extensive post-processing capability that allows users to format results in a variety of ways. Virtual instruments offer the ability to select input waveforms and probe circuit nodes, voltages, and waveforms, creating a dynamic quick-start tool.

NOTE

These files require that either the TINA software (from DesignSoft™) or TINA-TI software be installed. Download the free TINA-TI software from the [TINA-TI folder](#).

12.1.1.2 DIP Adapter EVM

The [DIP Adapter EVM](#) tool provides an easy, low-cost way to prototype small surface mount devices. The evaluation tool these TI packages: D or U (8-pin SOIC), PW (8-pin TSSOP), DGK (8-pin MSOP), DBV (6-pin SOT-23, 5-pin SOT-23, and 3-pin SOT-23), DCK (6-pin SC-70 and 5-pin SC-70), and DRL (6-pin SOT-563). The DIP Adapter EVM may also be used with terminal strips or may be wired directly to existing circuits.

12.1.1.3 Universal Op Amp EVM

The [Universal Op Amp EVM](#) is a series of general-purpose, blank circuit boards that simplify prototyping circuits for a variety of device package types. The evaluation module board design allows many different circuits to be constructed easily and quickly. Five models are offered, with each model intended for a specific package type. PDIP, SOIC, MSOP, TSSOP and SOT-23 packages are all supported.

NOTE

These boards are unpopulated, so users must provide their own devices. TI recommends requesting several op amp device samples when ordering the Universal Op Amp EVM.

12.1.1.4 TI Precision Designs

TI Precision Designs are analog solutions created by TI's precision analog applications experts and offer the theory of operation, component selection, simulation, complete PCB schematic and layout, bill of materials, and measured performance of many useful circuits. TI Precision Designs are available online at <http://www.ti.com/ww/en/analog/precision-designs/>.

12.1.1.5 WEBENCH® Filter Designer

[WEBENCH® Filter Designer](#) is a simple, powerful, and easy-to-use active filter design program. The WEBENCH Filter Designer allows the user to create optimized filter designs using a selection of TI operational amplifiers and passive components from TI's vendor partners.

Available as a web-based tool from the WEBENCH® Design Center, [WEBENCH® Filter Designer](#) allows the user to design, optimize, and simulate complete multistage active filter solutions within minutes.

12.2 Documentation Support

12.2.1 Related Documentation

The following documents are relevant to using the OPAx363 and OPAx364, and are recommended for reference. All are available for download at www.ti.com (unless otherwise noted):

- [AB-045 Op Amp Performance Analysis](#)
- [AB-067 Single-Supply Operation of Operational Amplifiers](#)
- [AB-105 Tuning in Amplifiers](#)
- [QFN/SON PCB Attachment](#)
- [Quad Flatpack No-Lead Logic Packages](#)

12.3 Related Links

The table below lists quick access links. Categories include technical documents, support and community resources, tools and software, and quick access to sample or buy.

Table 1. Related Links

PARTS	PRODUCT FOLDER	ORDER NOW	TECHNICAL DOCUMENTS	TOOLS & SOFTWARE	SUPPORT & COMMUNITY
OPA363	Click here	Click here	Click here	Click here	Click here
OPA2363	Click here	Click here	Click here	Click here	Click here
OPA364	Click here	Click here	Click here	Click here	Click here
OPA2364	Click here	Click here	Click here	Click here	Click here
OPA4364	Click here	Click here	Click here	Click here	Click here

12.4 Receiving Notification of Documentation Updates

To receive notification of documentation updates, navigate to the device product folder on ti.com. In the upper right corner, click on *Alert me* to register and receive a weekly digest of any product information that has changed. For change details, review the revision history included in any revised document.

12.5 Community Resource

The following links connect to TI community resources. Linked contents are provided "AS IS" by the respective contributors. They do not constitute TI specifications and do not necessarily reflect TI's views; see TI's [Terms of Use](#).

TI E2E™ Online Community *TI's Engineer-to-Engineer (E2E) Community*. Created to foster collaboration among engineers. At e2e.ti.com, you can ask questions, share knowledge, explore ideas and help solve problems with fellow engineers.

Design Support *TI's Design Support* Quickly find helpful E2E forums along with design support tools and contact information for technical support.

12.6 Trademarks

TINA-TI, E2E are trademarks of Texas Instruments.
 WEBENCH is a registered trademark of Texas Instruments.
 TINA, DesignSoft are trademarks of DesignSoft, Inc.
 All other trademarks are the property of their respective owners.

12.7 Electrostatic Discharge Caution



These devices have limited built-in ESD protection. The leads should be shorted together or the device placed in conductive foam during storage or handling to prevent electrostatic damage to the MOS gates.

12.8 Glossary

[SLYZ022](#) — *TI Glossary*.

This glossary lists and explains terms, acronyms, and definitions.

13 Mechanical, Packaging, and Orderable Information

The following pages include mechanical, packaging, and orderable information. This information is the most current data available for the designated devices. This data is subject to change without notice and revision of this document. For browser-based versions of this data sheet, refer to the left-hand navigation.

PACKAGING INFORMATION

Orderable Device	Status (1)	Package Type	Package Drawing	Pins	Package Qty	Eco Plan (2)	Lead/Ball Finish (6)	MSL Peak Temp (3)	Op Temp (°C)	Device Marking (4/5)	Samples
OPA2363AIDGSR	ACTIVE	VSSOP	DGS	10	2500	Green (RoHS & no Sb/Br)	CU NIPDAUAG	Level-2-260C-1 YEAR	-40 to 125	BHK	Samples
OPA2363AIDGST	ACTIVE	VSSOP	DGS	10	250	Green (RoHS & no Sb/Br)	CU NIPDAUAG	Level-2-260C-1 YEAR	-40 to 125	BHK	Samples
OPA2363AIDGSTG4	ACTIVE	VSSOP	DGS	10	250	Green (RoHS & no Sb/Br)	CU NIPDAUAG	Level-2-260C-1 YEAR	-40 to 125	BHK	Samples
OPA2363AIRSVR	ACTIVE	UQFN	RSV	16	3000	Green (RoHS & no Sb/Br)	CU NIPDAUAG	Level-2-260C-1 YEAR	-40 to 125	SIN	Samples
OPA2363IDGSR	ACTIVE	VSSOP	DGS	10	2500	Green (RoHS & no Sb/Br)	CU NIPDAUAG	Level-2-260C-1 YEAR	-40 to 125	BHK	Samples
OPA2363IDGST	ACTIVE	VSSOP	DGS	10	250	Green (RoHS & no Sb/Br)	CU NIPDAUAG	Level-2-260C-1 YEAR	-40 to 125	BHK	Samples
OPA2364AID	ACTIVE	SOIC	D	8	75	Green (RoHS & no Sb/Br)	CU NIPDAU	Level-2-260C-1 YEAR	-40 to 125	OPA 2364 A	Samples
OPA2364AIDG4	ACTIVE	SOIC	D	8	75	Green (RoHS & no Sb/Br)	CU NIPDAU	Level-2-260C-1 YEAR	-40 to 125	OPA 2364 A	Samples
OPA2364AIDGKR	ACTIVE	VSSOP	DGK	8	2500	Green (RoHS & no Sb/Br)	CU NIPDAUAG	Level-2-260C-1 YEAR	-40 to 125	BHL	Samples
OPA2364AIDGKRG4	ACTIVE	VSSOP	DGK	8	2500	Green (RoHS & no Sb/Br)	CU NIPDAUAG	Level-2-260C-1 YEAR	-40 to 125	BHL	Samples
OPA2364AIDGKT	ACTIVE	VSSOP	DGK	8	250	Green (RoHS & no Sb/Br)	CU NIPDAUAG	Level-2-260C-1 YEAR	-40 to 125	BHL	Samples
OPA2364AIDGKTG4	ACTIVE	VSSOP	DGK	8	250	Green (RoHS & no Sb/Br)	CU NIPDAUAG	Level-2-260C-1 YEAR	-40 to 125	BHL	Samples
OPA2364AIDR	ACTIVE	SOIC	D	8	2500	Green (RoHS & no Sb/Br)	CU NIPDAU	Level-2-260C-1 YEAR	-40 to 125	OPA 2364 A	Samples
OPA2364AIDRG4	ACTIVE	SOIC	D	8	2500	Green (RoHS & no Sb/Br)	CU NIPDAU	Level-2-260C-1 YEAR	-40 to 125	OPA 2364 A	Samples
OPA2364ID	ACTIVE	SOIC	D	8	75	Green (RoHS & no Sb/Br)	CU NIPDAU	Level-2-260C-1 YEAR	-40 to 125	OPA 2364	Samples

Orderable Device	Status (1)	Package Type	Package Drawing	Pins	Package Qty	Eco Plan (2)	Lead/Ball Finish (6)	MSL Peak Temp (3)	Op Temp (°C)	Device Marking (4/5)	Samples
OPA2364IDGKR	ACTIVE	VSSOP	DGK	8	2500	Green (RoHS & no Sb/Br)	CU NIPDAUAG	Level-2-260C-1 YEAR	-40 to 125	BHL	Samples
OPA2364IDGKT	ACTIVE	VSSOP	DGK	8	250	Green (RoHS & no Sb/Br)	CU NIPDAUAG	Level-2-260C-1 YEAR	-40 to 125	BHL	Samples
OPA2364IDGKTG4	ACTIVE	VSSOP	DGK	8	250	Green (RoHS & no Sb/Br)	CU NIPDAUAG	Level-2-260C-1 YEAR	-40 to 125	BHL	Samples
OPA2364IDR	ACTIVE	SOIC	D	8	2500	Green (RoHS & no Sb/Br)	CU NIPDAU	Level-2-260C-1 YEAR	-40 to 125	OPA 2364	Samples
OPA2364IDRG4	ACTIVE	SOIC	D	8	2500	Green (RoHS & no Sb/Br)	CU NIPDAU	Level-2-260C-1 YEAR	-40 to 125	OPA 2364	Samples
OPA363AID	ACTIVE	SOIC	D	8	75	Green (RoHS & no Sb/Br)	CU NIPDAU	Level-2-260C-1 YEAR	-40 to 125	OPA 363 A	Samples
OPA363AIDBVR	ACTIVE	SOT-23	DBV	6	3000	Green (RoHS & no Sb/Br)	CU NIPDAU	Level-2-260C-1 YEAR	-40 to 125	A40	Samples
OPA363AIDBVT	ACTIVE	SOT-23	DBV	6	250	Green (RoHS & no Sb/Br)	CU NIPDAU	Level-2-260C-1 YEAR	-40 to 125	A40	Samples
OPA363AIDBVTG4	ACTIVE	SOT-23	DBV	6	250	Green (RoHS & no Sb/Br)	CU NIPDAU	Level-2-260C-1 YEAR	-40 to 125	A40	Samples
OPA363ID	ACTIVE	SOIC	D	8	75	Green (RoHS & no Sb/Br)	CU NIPDAU	Level-2-260C-1 YEAR	-40 to 125	OPA 363	Samples
OPA363IDBVR	ACTIVE	SOT-23	DBV	6	3000	Green (RoHS & no Sb/Br)	CU NIPDAU	Level-2-260C-1 YEAR	-40 to 125	A40	Samples
OPA363IDBVT	ACTIVE	SOT-23	DBV	6	250	Green (RoHS & no Sb/Br)	CU NIPDAU	Level-2-260C-1 YEAR	-40 to 125	A40	Samples
OPA363IDBVTG4	ACTIVE	SOT-23	DBV	6	250	Green (RoHS & no Sb/Br)	CU NIPDAU	Level-2-260C-1 YEAR	-40 to 125	A40	Samples
OPA364AID	ACTIVE	SOIC	D	8	75	Green (RoHS & no Sb/Br)	CU NIPDAU	Level-2-260C-1 YEAR	-40 to 125	OPA 364 A	Samples
OPA364AIDBVR	ACTIVE	SOT-23	DBV	5	3000	Green (RoHS & no Sb/Br)	CU NIPDAU	Level-2-260C-1 YEAR	-40 to 125	A41	Samples
OPA364AIDBVT	ACTIVE	SOT-23	DBV	5	250	Green (RoHS & no Sb/Br)	CU NIPDAU	Level-2-260C-1 YEAR	-40 to 125	A41	Samples
OPA364AIDBVTG4	ACTIVE	SOT-23	DBV	5	250	Green (RoHS & no Sb/Br)	CU NIPDAU	Level-2-260C-1 YEAR	-40 to 125	A41	Samples

Orderable Device	Status (1)	Package Type	Package Drawing	Pins	Package Qty	Eco Plan (2)	Lead/Ball Finish (6)	MSL Peak Temp (3)	Op Temp (°C)	Device Marking (4/5)	Samples
OPA364AIDR	ACTIVE	SOIC	D	8	2500	Green (RoHS & no Sb/Br)	CU NIPDAU	Level-2-260C-1 YEAR	-40 to 125	OPA 364 A	Samples
OPA364ID	ACTIVE	SOIC	D	8	75	Green (RoHS & no Sb/Br)	CU NIPDAU	Level-2-260C-1 YEAR	-40 to 125	OPA 364	Samples
OPA364IDBVR	ACTIVE	SOT-23	DBV	5	3000	Green (RoHS & no Sb/Br)	CU NIPDAU	Level-2-260C-1 YEAR	-40 to 125	A41	Samples
OPA364IDBVRG4	ACTIVE	SOT-23	DBV	5	3000	Green (RoHS & no Sb/Br)	CU NIPDAU	Level-2-260C-1 YEAR	-40 to 125	A41	Samples
OPA364IDBVT	ACTIVE	SOT-23	DBV	5	250	Green (RoHS & no Sb/Br)	CU NIPDAU	Level-2-260C-1 YEAR	-40 to 125	A41	Samples
OPA364IDBVTG4	ACTIVE	SOT-23	DBV	5	250	Green (RoHS & no Sb/Br)	CU NIPDAU	Level-2-260C-1 YEAR	-40 to 125	A41	Samples
OPA364IDG4	ACTIVE	SOIC	D	8	75	Green (RoHS & no Sb/Br)	CU NIPDAU	Level-2-260C-1 YEAR	-40 to 125	OPA 364	Samples
OPA364IDR	ACTIVE	SOIC	D	8	2500	Green (RoHS & no Sb/Br)	CU NIPDAU	Level-2-260C-1 YEAR	-40 to 125	OPA 364	Samples
OPA4364AID	ACTIVE	SOIC	D	14	50	Green (RoHS & no Sb/Br)	CU NIPDAU	Level-2-260C-1 YEAR	-40 to 125	OPA4364A	Samples
OPA4364AIDR	ACTIVE	SOIC	D	14	2500	Green (RoHS & no Sb/Br)	CU NIPDAU	Level-2-260C-1 YEAR	-40 to 125	OPA4364A	Samples
OPA4364AIDRG4	ACTIVE	SOIC	D	14	2500	Green (RoHS & no Sb/Br)	CU NIPDAU	Level-2-260C-1 YEAR	-40 to 125	OPA4364A	Samples
OPA4364AIPWR	ACTIVE	TSSOP	PW	14	2500	Green (RoHS & no Sb/Br)	CU NIPDAU	Level-2-260C-1 YEAR	-40 to 125	OPA 4364A	Samples
OPA4364AIPWT	ACTIVE	TSSOP	PW	14	250	Green (RoHS & no Sb/Br)	CU NIPDAU	Level-2-260C-1 YEAR	-40 to 125	OPA 4364A	Samples
OPA4364AIPWTG4	ACTIVE	TSSOP	PW	14	250	Green (RoHS & no Sb/Br)	CU NIPDAU	Level-2-260C-1 YEAR	-40 to 125	OPA 4364A	Samples

(1) The marketing status values are defined as follows:

ACTIVE: Product device recommended for new designs.

LIFEBUY: TI has announced that the device will be discontinued, and a lifetime-buy period is in effect.

NRND: Not recommended for new designs. Device is in production to support existing customers, but TI does not recommend using this part in a new design.

PREVIEW: Device has been announced but is not in production. Samples may or may not be available.

OBSELETE: TI has discontinued the production of the device.

(2) **RoHS:** TI defines "RoHS" to mean semiconductor products that are compliant with the current EU RoHS requirements for all 10 RoHS substances, including the requirement that RoHS substance do not exceed 0.1% by weight in homogeneous materials. Where designed to be soldered at high temperatures, "RoHS" products are suitable for use in specified lead-free processes. TI may reference these types of products as "Pb-Free".

RoHS Exempt: TI defines "RoHS Exempt" to mean products that contain lead but are compliant with EU RoHS pursuant to a specific EU RoHS exemption.

Green: TI defines "Green" to mean the content of Chlorine (Cl) and Bromine (Br) based flame retardants meet JS709B low halogen requirements of ≤ 1000 ppm threshold. Antimony trioxide based flame retardants must also meet the ≤ 1000 ppm threshold requirement.

(3) MSL, Peak Temp. - The Moisture Sensitivity Level rating according to the JEDEC industry standard classifications, and peak solder temperature.

(4) There may be additional marking, which relates to the logo, the lot trace code information, or the environmental category on the device.

(5) Multiple Device Markings will be inside parentheses. Only one Device Marking contained in parentheses and separated by a "~" will appear on a device. If a line is indented then it is a continuation of the previous line and the two combined represent the entire Device Marking for that device.

(6) Lead/Ball Finish - Orderable Devices may have multiple material finish options. Finish options are separated by a vertical ruled line. Lead/Ball Finish values may wrap to two lines if the finish value exceeds the maximum column width.

Important Information and Disclaimer: The information provided on this page represents TI's knowledge and belief as of the date that it is provided. TI bases its knowledge and belief on information provided by third parties, and makes no representation or warranty as to the accuracy of such information. Efforts are underway to better integrate information from third parties. TI has taken and continues to take reasonable steps to provide representative and accurate information but may not have conducted destructive testing or chemical analysis on incoming materials and chemicals. TI and TI suppliers consider certain information to be proprietary, and thus CAS numbers and other limited information may not be available for release.

In no event shall TI's liability arising out of such information exceed the total purchase price of the TI part(s) at issue in this document sold by TI to Customer on an annual basis.

OTHER QUALIFIED VERSIONS OF OPA4364 :

- Automotive: [OPA4364-Q1](#)

NOTE: Qualified Version Definitions:

- Automotive - Q100 devices qualified for high-reliability automotive applications targeting zero defects

TAPE AND REEL INFORMATION



QUADRANT ASSIGNMENTS FOR PIN 1 ORIENTATION IN TAPE



*All dimensions are nominal

Device	Package Type	Package Drawing	Pins	SPQ	Reel Diameter (mm)	Reel Width W1 (mm)	A0 (mm)	B0 (mm)	K0 (mm)	P1 (mm)	W (mm)	Pin1 Quadrant
OPA2363AIDGSR	VSSOP	DGS	10	2500	330.0	12.4	5.3	3.4	1.4	8.0	12.0	Q1
OPA2363AIDGST	VSSOP	DGS	10	250	180.0	12.4	5.3	3.4	1.4	8.0	12.0	Q1
OPA2363AIRSVR	UQFN	RSV	16	3000	177.8	12.4	2.0	2.8	0.7	4.0	12.0	Q1
OPA2363IDGSR	VSSOP	DGS	10	2500	330.0	12.4	5.3	3.4	1.4	8.0	12.0	Q1
OPA2363IDGST	VSSOP	DGS	10	250	180.0	12.4	5.3	3.4	1.4	8.0	12.0	Q1
OPA2364AIDGKR	VSSOP	DGK	8	2500	330.0	12.4	5.3	3.4	1.4	8.0	12.0	Q1
OPA2364AIDGKT	VSSOP	DGK	8	250	180.0	12.4	5.3	3.4	1.4	8.0	12.0	Q1
OPA2364AIDR	SOIC	D	8	2500	330.0	12.4	6.4	5.2	2.1	8.0	12.0	Q1
OPA2364IDGKR	VSSOP	DGK	8	2500	330.0	12.4	5.3	3.4	1.4	8.0	12.0	Q1
OPA2364IDGKT	VSSOP	DGK	8	250	180.0	12.4	5.3	3.4	1.4	8.0	12.0	Q1
OPA2364IDR	SOIC	D	8	2500	330.0	12.4	6.4	5.2	2.1	8.0	12.0	Q1
OPA363AIDBVR	SOT-23	DBV	6	3000	178.0	9.0	3.23	3.17	1.37	4.0	8.0	Q3
OPA363AIDBVT	SOT-23	DBV	6	250	178.0	9.0	3.23	3.17	1.37	4.0	8.0	Q3
OPA363IDBVR	SOT-23	DBV	6	3000	178.0	9.0	3.23	3.17	1.37	4.0	8.0	Q3
OPA363IDBVT	SOT-23	DBV	6	250	178.0	9.0	3.23	3.17	1.37	4.0	8.0	Q3
OPA364AIDR	SOIC	D	8	2500	330.0	12.4	6.4	5.2	2.1	8.0	12.0	Q1
OPA364IDR	SOIC	D	8	2500	330.0	12.4	6.4	5.2	2.1	8.0	12.0	Q1
OPA4364AIDR	SOIC	D	14	2500	330.0	16.4	6.5	9.0	2.1	8.0	16.0	Q1

Device	Package Type	Package Drawing	Pins	SPQ	Reel Diameter (mm)	Reel Width W1 (mm)	A0 (mm)	B0 (mm)	K0 (mm)	P1 (mm)	W (mm)	Pin1 Quadrant
OPA4364AIPWR	TSSOP	PW	14	2500	330.0	12.4	6.9	5.6	1.6	8.0	12.0	Q1
OPA4364AIPWT	TSSOP	PW	14	250	180.0	12.4	6.9	5.6	1.6	8.0	12.0	Q1

TAPE AND REEL BOX DIMENSIONS

*All dimensions are nominal

Device	Package Type	Package Drawing	Pins	SPQ	Length (mm)	Width (mm)	Height (mm)
OPA2363AIDGSR	VSSOP	DGS	10	2500	367.0	367.0	35.0
OPA2363AIDGST	VSSOP	DGS	10	250	210.0	185.0	35.0
OPA2363AIRSVR	UQFN	RSV	16	3000	223.0	270.0	35.0
OPA2363IDGSR	VSSOP	DGS	10	2500	367.0	367.0	35.0
OPA2363IDGST	VSSOP	DGS	10	250	210.0	185.0	35.0
OPA2364AIDGKR	VSSOP	DGK	8	2500	367.0	367.0	35.0
OPA2364AIDGKT	VSSOP	DGK	8	250	210.0	185.0	35.0
OPA2364AIDR	SOIC	D	8	2500	367.0	367.0	35.0
OPA2364IDGKR	VSSOP	DGK	8	2500	367.0	367.0	35.0
OPA2364IDGKT	VSSOP	DGK	8	250	210.0	185.0	35.0
OPA2364IDR	SOIC	D	8	2500	367.0	367.0	35.0
OPA363AIDBVR	SOT-23	DBV	6	3000	565.0	140.0	75.0
OPA363AIDBVT	SOT-23	DBV	6	250	565.0	140.0	75.0
OPA363IDBVR	SOT-23	DBV	6	3000	565.0	140.0	75.0
OPA363IDBVT	SOT-23	DBV	6	250	565.0	140.0	75.0

Device	Package Type	Package Drawing	Pins	SPQ	Length (mm)	Width (mm)	Height (mm)
OPA364AIDR	SOIC	D	8	2500	367.0	367.0	35.0
OPA364IDR	SOIC	D	8	2500	367.0	367.0	35.0
OPA4364AIDR	SOIC	D	14	2500	367.0	367.0	38.0
OPA4364AIPWR	TSSOP	PW	14	2500	367.0	367.0	35.0
OPA4364AIPWT	TSSOP	PW	14	250	210.0	185.0	35.0

EXAMPLE BOARD LAYOUT

DBV0006A

SOT-23 - 1.45 mm max height

SMALL OUTLINE TRANSISTOR



LAND PATTERN EXAMPLE
EXPOSED METAL SHOWN
SCALE:15X

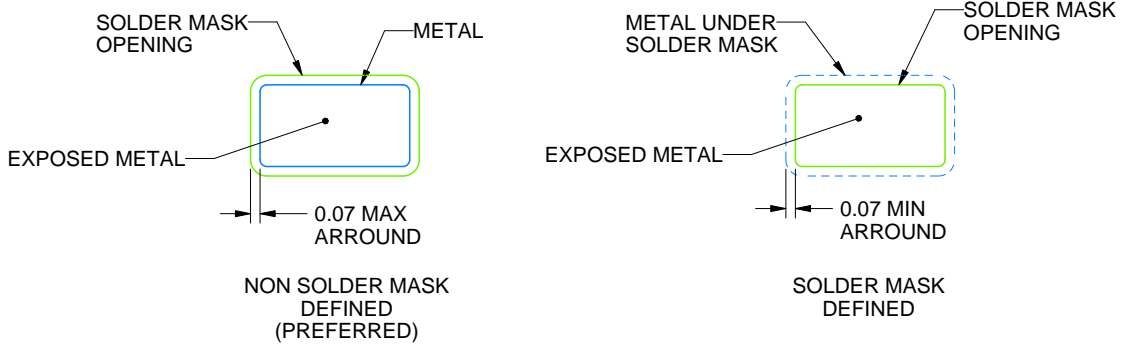

SOLDER MASK DETAILS

4214840/B 03/2018

NOTES: (continued)

6. Publication IPC-7351 may have alternate designs.

7. Solder mask tolerances between and around signal pads can vary based on board fabrication site.

EXAMPLE STENCIL DESIGN

DBV0006A

SOT-23 - 1.45 mm max height

SMALL OUTLINE TRANSISTOR



SOLDER PASTE EXAMPLE
BASED ON 0.125 mm THICK STENCIL
SCALE:15X

4214840/B 03/2018

NOTES: (continued)

8. Laser cutting apertures with trapezoidal walls and rounded corners may offer better paste release. IPC-7525 may have alternate design recommendations.
9. Board assembly site may have different recommendations for stencil design.

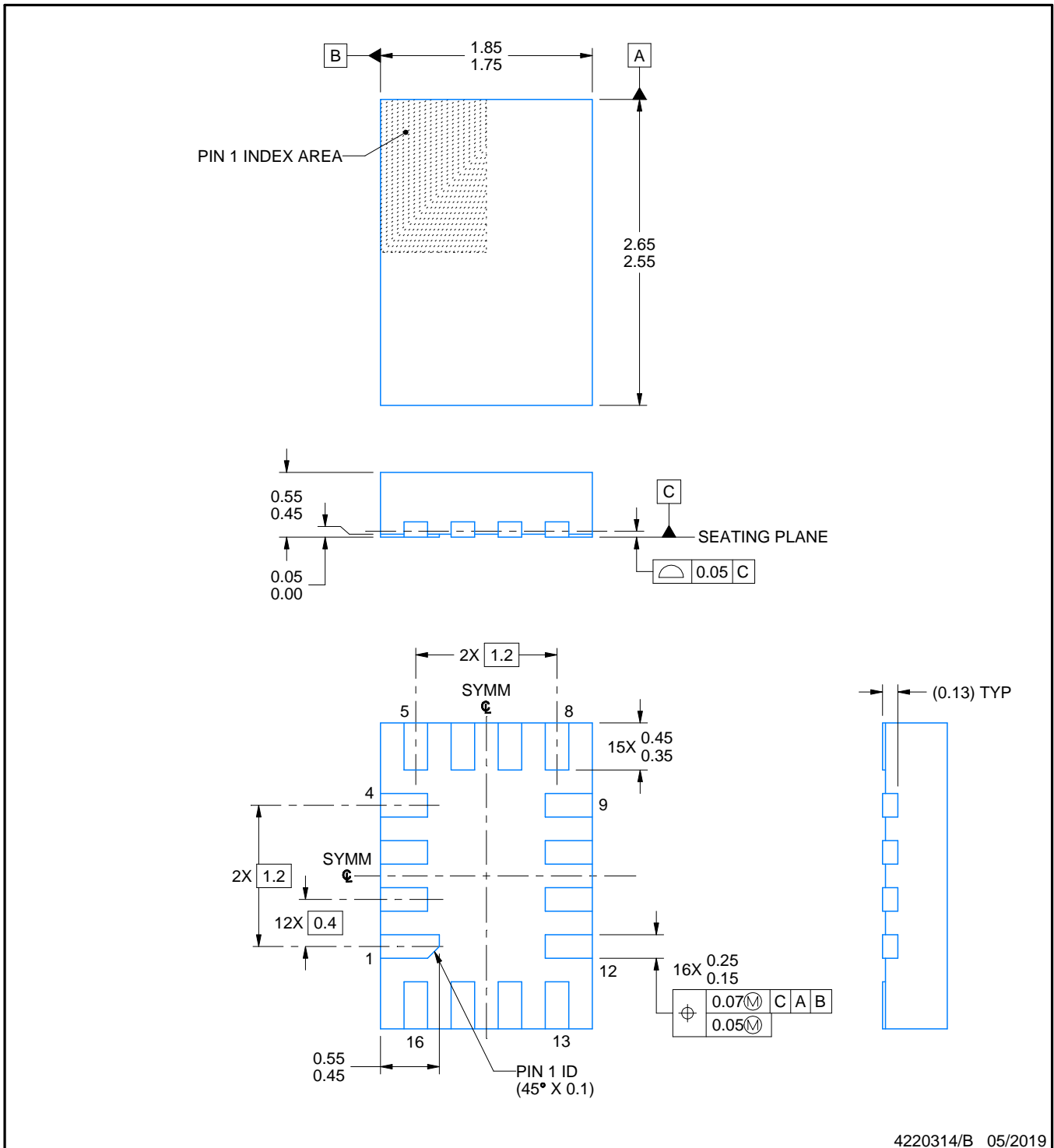
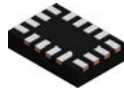

4220314/B 05/2019

NOTES:

1. All linear dimensions are in millimeters. Any dimensions in parenthesis are for reference only. Dimensioning and tolerancing per ASME Y14.5M.
2. This drawing is subject to change without notice.

EXAMPLE BOARD LAYOUT

RSV0016A

UQFN - 0.55 mm max height

ULTRA THIN QUAD FLATPACK - NO LEAD



LAND PATTERN EXAMPLE
EXPOSED METAL SHOWN
SCALE: 25X



4220314/B 05/2019

NOTES: (continued)

- This package is designed to be soldered to a thermal pad on the board. For more information, see Texas Instruments literature number SLUA271 (www.ti.com/lit/slua271).

EXAMPLE STENCIL DESIGN

RSV0016A

UQFN - 0.55 mm max height

ULTRA THIN QUAD FLATPACK - NO LEAD



SOLDER PASTE EXAMPLE
BASED ON 0.125 MM THICK STENCIL
SCALE: 25X

4220314/B 05/2019

NOTES: (continued)

4. Laser cutting apertures with trapezoidal walls and rounded corners may offer better paste release. IPC-7525 may have alternate design recommendations.

DGS0010A

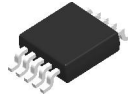

PACKAGE OUTLINE

VSSOP - 1.1 mm max height

SMALL OUTLINE PACKAGE



4221984/A 05/2015

NOTES:

1. All linear dimensions are in millimeters. Any dimensions in parenthesis are for reference only. Dimensioning and tolerancing per ASME Y14.5M.
2. This drawing is subject to change without notice.
3. This dimension does not include mold flash, protrusions, or gate burrs. Mold flash, protrusions, or gate burrs shall not exceed 0.15 mm per side.
4. This dimension does not include interlead flash. Interlead flash shall not exceed 0.25 mm per side.
5. Reference JEDEC registration MO-187, variation BA.

EXAMPLE BOARD LAYOUT

DGS0010A

VSSOP - 1.1 mm max height

SMALL OUTLINE PACKAGE



LAND PATTERN EXAMPLE
SCALE:10X

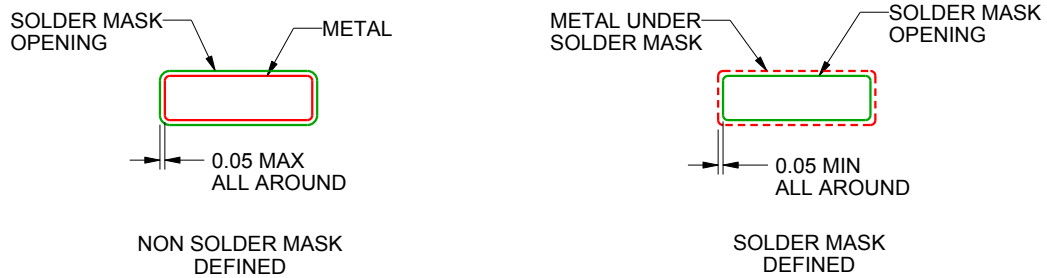

SOLDER MASK DETAILS
NOT TO SCALE

4221984/A 05/2015

NOTES: (continued)

- 6. Publication IPC-7351 may have alternate designs.
- 7. Solder mask tolerances between and around signal pads can vary based on board fabrication site.

EXAMPLE STENCIL DESIGN

DGS0010A

VSSOP - 1.1 mm max height

SMALL OUTLINE PACKAGE



SOLDER PASTE EXAMPLE
BASED ON 0.125 mm THICK STENCIL
SCALE:10X

4221984/A 05/2015

NOTES: (continued)

8. Laser cutting apertures with trapezoidal walls and rounded corners may offer better paste release. IPC-7525 may have alternate design recommendations.
9. Board assembly site may have different recommendations for stencil design.

D (R-PDSO-G14)

PLASTIC SMALL OUTLINE

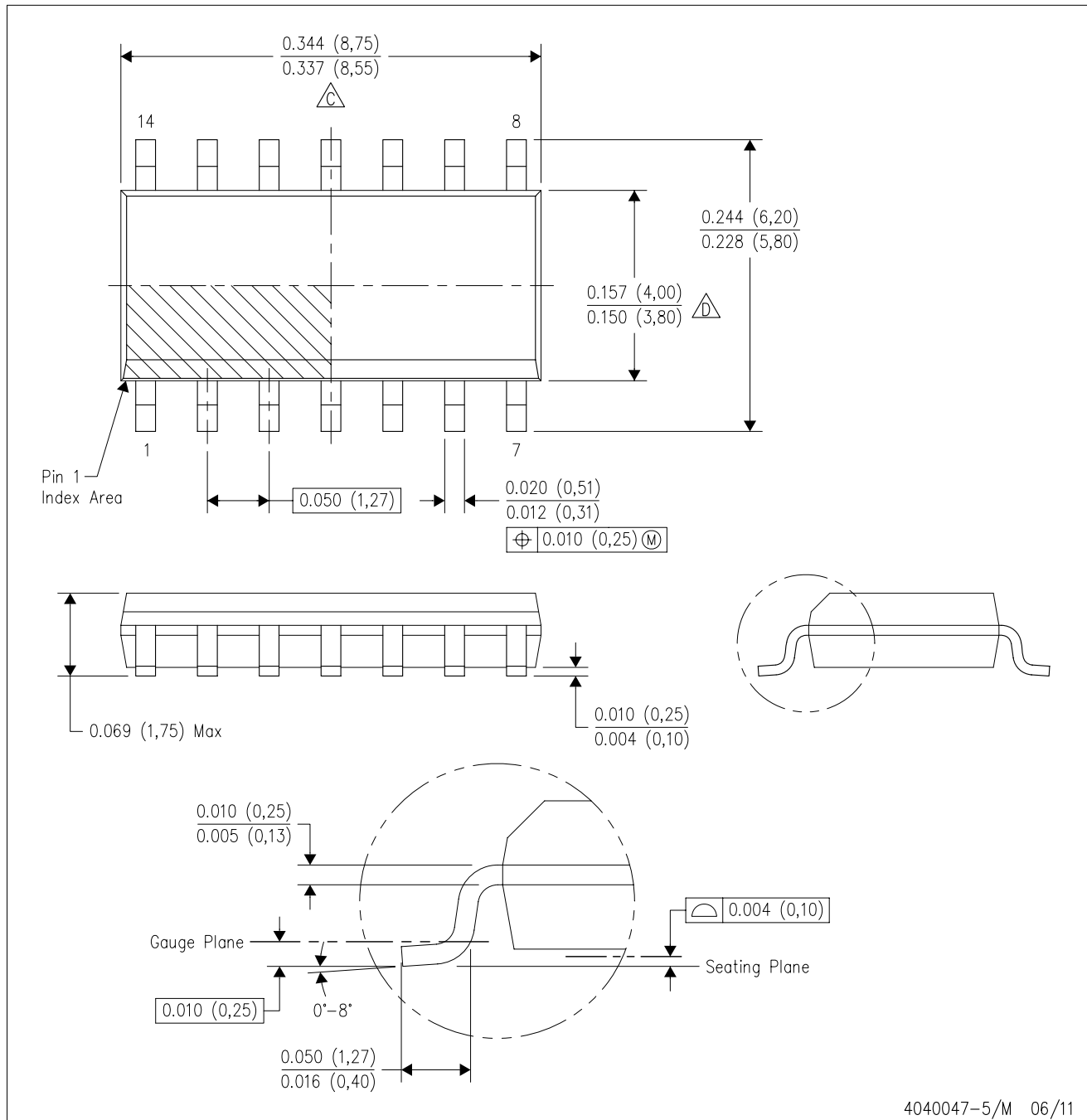

- NOTES:
- A. All linear dimensions are in inches (millimeters).
 - B. This drawing is subject to change without notice.
 - $\triangle C$ Body length does not include mold flash, protrusions, or gate burrs. Mold flash, protrusions, or gate burrs shall not exceed 0.006 (0,15) each side.
 - $\triangle D$ Body width does not include interlead flash. Interlead flash shall not exceed 0.017 (0,43) each side.
 - E. Reference JEDEC MS-012 variation AB.

D (R-PDSO-G14)

PLASTIC SMALL OUTLINE

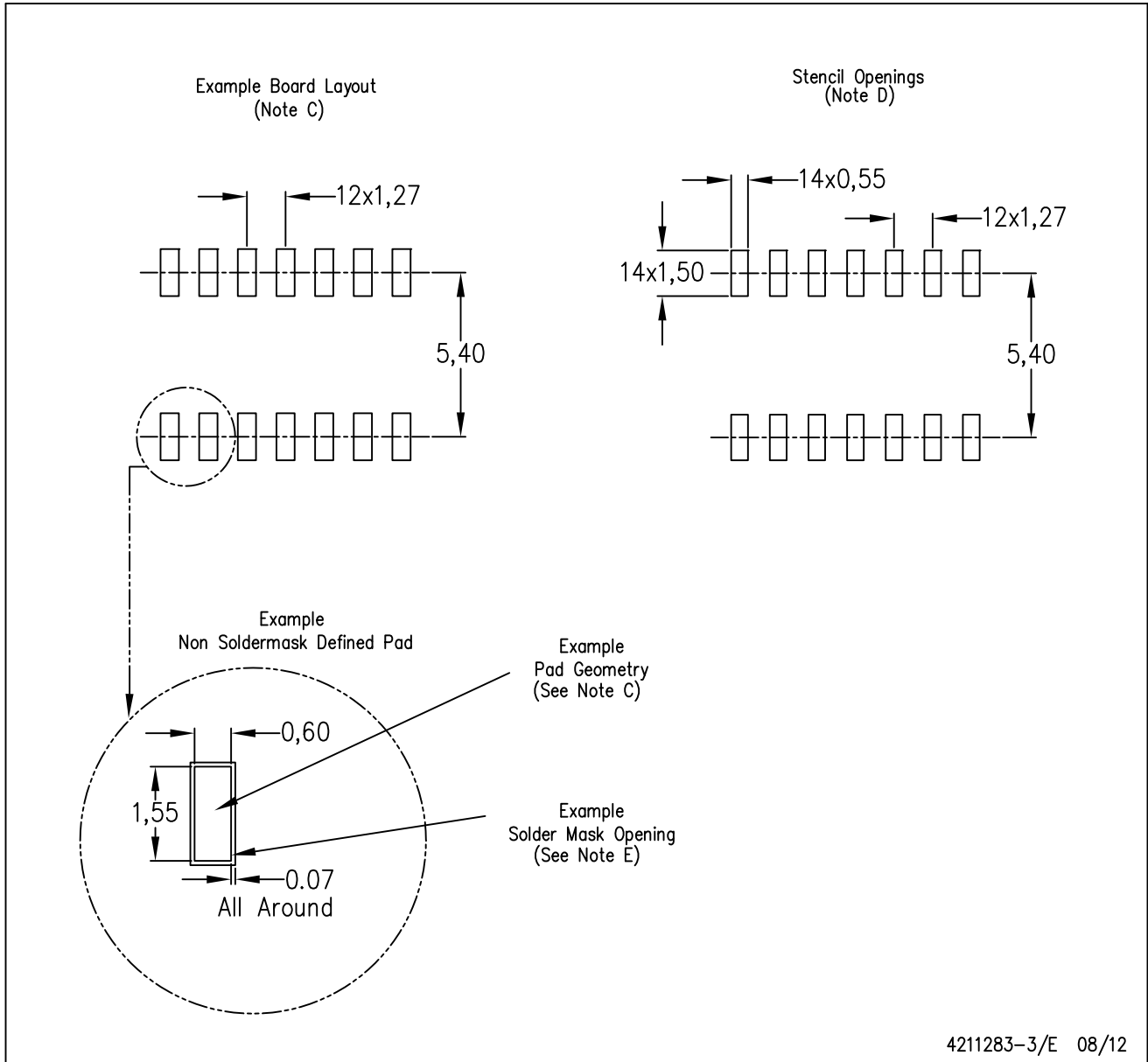

- NOTES:
- A. All linear dimensions are in millimeters.
 - B. This drawing is subject to change without notice.
 - C. Publication IPC-7351 is recommended for alternate designs.
 - D. Laser cutting apertures with trapezoidal walls and also rounding corners will offer better paste release. Customers should contact their board assembly site for stencil design recommendations. Refer to IPC-7525 for other stencil recommendations.
 - E. Customers should contact their board fabrication site for solder mask tolerances between and around signal pads.

PW (R-PDSO-G14)

PLASTIC SMALL OUTLINE



- NOTES:
- All linear dimensions are in millimeters.
 - This drawing is subject to change without notice.
 - Publication IPC-7351 is recommended for alternate designs.
 - Laser cutting apertures with trapezoidal walls and also rounding corners will offer better paste release. Customers should contact their board assembly site for stencil design recommendations. Refer to IPC-7525 for other stencil recommendations.
 - Customers should contact their board fabrication site for solder mask tolerances between and around signal pads.



D0008A

PACKAGE OUTLINE

SOIC - 1.75 mm max height

SMALL OUTLINE INTEGRATED CIRCUIT



4214825/C 02/2019

NOTES:

- Linear dimensions are in inches [millimeters]. Dimensions in parenthesis are for reference only. Controlling dimensions are in inches. Dimensioning and tolerancing per ASME Y14.5M.
- This drawing is subject to change without notice.
- This dimension does not include mold flash, protrusions, or gate burrs. Mold flash, protrusions, or gate burrs shall not exceed $.006$ [0.15] per side.
- This dimension does not include interlead flash.
- Reference JEDEC registration MS-012, variation AA.

EXAMPLE BOARD LAYOUT

D0008A

SOIC - 1.75 mm max height

SMALL OUTLINE INTEGRATED CIRCUIT



LAND PATTERN EXAMPLE
 EXPOSED METAL SHOWN
 SCALE:8X



SOLDER MASK DETAILS

4214825/C 02/2019

NOTES: (continued)

- 6. Publication IPC-7351 may have alternate designs.
- 7. Solder mask tolerances between and around signal pads can vary based on board fabrication site.

EXAMPLE STENCIL DESIGN

D0008A

SOIC - 1.75 mm max height

SMALL OUTLINE INTEGRATED CIRCUIT



SOLDER PASTE EXAMPLE
BASED ON .005 INCH [0.125 MM] THICK STENCIL
SCALE:8X

4214825/C 02/2019

NOTES: (continued)

8. Laser cutting apertures with trapezoidal walls and rounded corners may offer better paste release. IPC-7525 may have alternate design recommendations.
9. Board assembly site may have different recommendations for stencil design.

DBV0005A



PACKAGE OUTLINE

SOT-23 - 1.45 mm max height

SMALL OUTLINE TRANSISTOR



4214839/D 11/2018

NOTES:

1. All linear dimensions are in millimeters. Any dimensions in parenthesis are for reference only. Dimensioning and tolerancing per ASME Y14.5M.
2. This drawing is subject to change without notice.
3. Reference JEDEC MO-178.
4. Body dimensions do not include mold flash, protrusions, or gate burrs. Mold flash, protrusions, or gate burrs shall not exceed 0.15 mm per side.

EXAMPLE BOARD LAYOUT

DBV0005A

SOT-23 - 1.45 mm max height

SMALL OUTLINE TRANSISTOR



LAND PATTERN EXAMPLE
EXPOSED METAL SHOWN
SCALE:15X

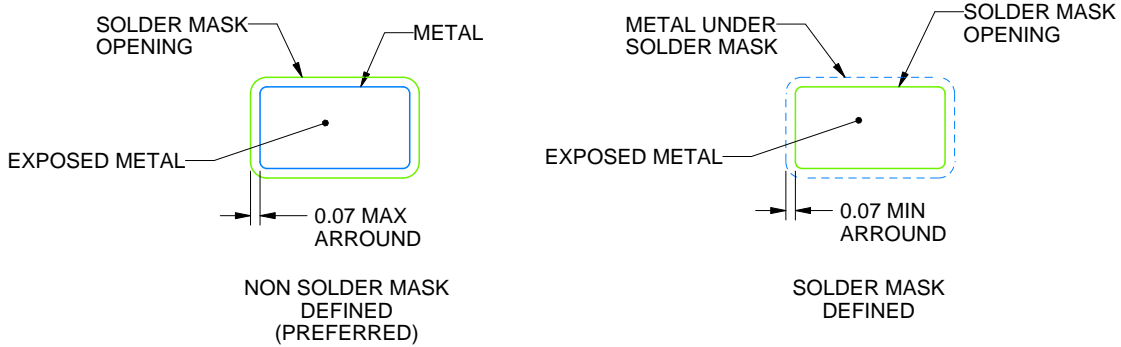

SOLDER MASK DETAILS

4214839/D 11/2018

NOTES: (continued)

5. Publication IPC-7351 may have alternate designs.
6. Solder mask tolerances between and around signal pads can vary based on board fabrication site.

EXAMPLE STENCIL DESIGN

DBV0005A

SOT-23 - 1.45 mm max height

SMALL OUTLINE TRANSISTOR



SOLDER PASTE EXAMPLE
BASED ON 0.125 mm THICK STENCIL
SCALE:15X

4214839/D 11/2018

NOTES: (continued)

7. Laser cutting apertures with trapezoidal walls and rounded corners may offer better paste release. IPC-7525 may have alternate design recommendations.
8. Board assembly site may have different recommendations for stencil design.

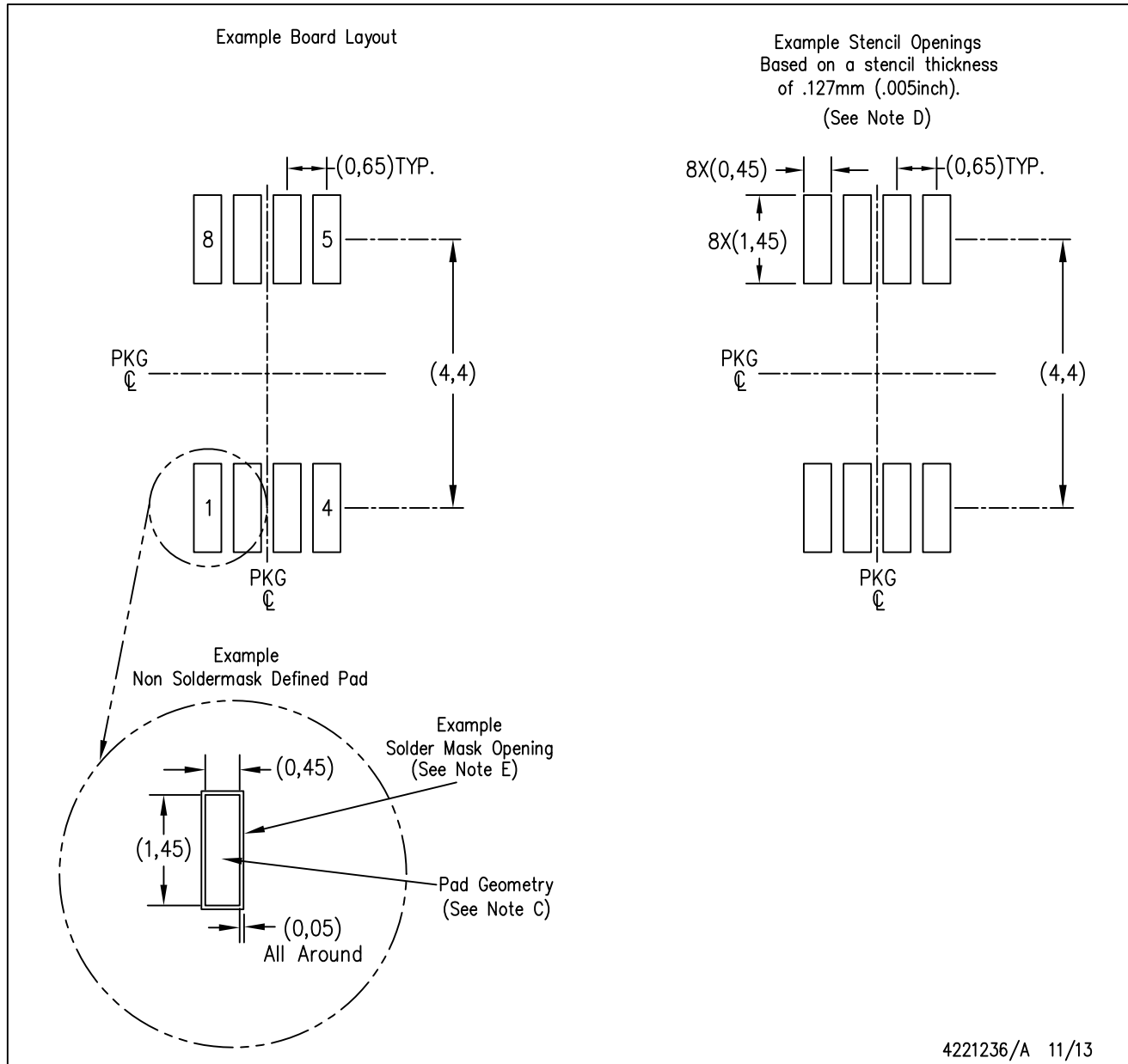

- NOTES:
- A. All linear dimensions are in millimeters.
 - B. This drawing is subject to change without notice.
 - C. Publication IPC-7351 is recommended for alternate designs.
 - D. Laser cutting apertures with trapezoidal walls and also rounding corners will offer better paste release. Customers should contact their board assembly site for stencil design recommendations. Refer to IPC-7525 for other stencil recommendations.
 - E. Customers should contact their board fabrication site for solder mask tolerances between and around signal pads.

IMPORTANT NOTICE AND DISCLAIMER

TI PROVIDES TECHNICAL AND RELIABILITY DATA (INCLUDING DATASHEETS), DESIGN RESOURCES (INCLUDING REFERENCE DESIGNS), APPLICATION OR OTHER DESIGN ADVICE, WEB TOOLS, SAFETY INFORMATION, AND OTHER RESOURCES "AS IS" AND WITH ALL FAULTS, AND DISCLAIMS ALL WARRANTIES, EXPRESS AND IMPLIED, INCLUDING WITHOUT LIMITATION ANY IMPLIED WARRANTIES OF MERCHANTABILITY, FITNESS FOR A PARTICULAR PURPOSE OR NON-INFRINGEMENT OF THIRD PARTY INTELLECTUAL PROPERTY RIGHTS.

These resources are intended for skilled developers designing with TI products. You are solely responsible for (1) selecting the appropriate TI products for your application, (2) designing, validating and testing your application, and (3) ensuring your application meets applicable standards, and any other safety, security, or other requirements. These resources are subject to change without notice. TI grants you permission to use these resources only for development of an application that uses the TI products described in the resource. Other reproduction and display of these resources is prohibited. No license is granted to any other TI intellectual property right or to any third party intellectual property right. TI disclaims responsibility for, and you will fully indemnify TI and its representatives against, any claims, damages, costs, losses, and liabilities arising out of your use of these resources.

TI's products are provided subject to TI's Terms of Sale (www.ti.com/legal/termsofsale.html) or other applicable terms available either on ti.com or provided in conjunction with such TI products. TI's provision of these resources does not expand or otherwise alter TI's applicable warranties or warranty disclaimers for TI products.

Mailing Address: Texas Instruments, Post Office Box 655303, Dallas, Texas 75265
Copyright © 2019, Texas Instruments Incorporated

Looking for pricing, stock, or lifecycle information?

Click below to explore more details on WIN SOURCE:

 [View OPA363IDBVR](#) on WIN SOURCE

 [Texas Instruments](#) Information

Optimize Your Supply Chain with WIN SOURCE Solutions

-  Global Sourcing Solution
-  Obsolete Management
-  Cost Control Management
-  Shortage Management
-  Alternative Solution
-  Excess Inventory Management