



THE DATASHEET OF
2N6426





ELECTRONICS, INC.
 44 FARRAND STREET
 BLOOMFIELD, NJ 07003
 (973) 748-5089
<http://www.nteinc.com>

2N6426

Silicon NPN Transistor Darlington General Purpose Amplifier TO-92 Type Package

Absolute Maximum Ratings:

Collector-Emitter Voltage, V_{CEO}	40V
Collector-Base Voltage, V_{CBO}	40V
Emitter-Base Voltage, V_{EBO}	12V
Continuous Collector Current, I_C	500mA
Total Device Dissipation ($T_A = +25^\circ\text{C}$), P_D	625W
Derate Above 25°C	5.0mW/ $^\circ\text{C}$
Total Device Dissipation ($T_C = +25^\circ\text{C}$), P_D	1.5W
Derate Above 25°C	12mW/ $^\circ\text{C}$
Operating Junction Temperature Range, T_J	-55° to $+150^\circ\text{C}$
Storage Temperature Range, T_{stg}	-55° to $+150^\circ\text{C}$
Thermal Resistance, Junction-to-Ambient, R_{thJA}	200°C/W
Thermal Resistance, Junction-to-Case, R_{thJC}	83.3°C/W

Electrical Characteristics: ($T_A = +25^\circ\text{C}$ unless otherwise specified)

Parameter	Symbol	Test Conditions	Min	Typ	Max	Unit
OFF Characteristics						
Collector-Emitter Breakdown Voltage	$V_{(BR)CEO}$	$I_C = 10\text{mA}$, $V_{BE} = 0$, Note 1	40	-	-	V
Collector-Base Breakdown Voltage	$V_{(BR)CBO}$	$I_C = 100\mu\text{A}$, $I_E = 0$	40	-	-	V
Emitter-Base Breakdown Voltage	$V_{(BR)EBO}$	$I_E = 10\mu\text{A}$, $I_C = 0$	12	-	-	V
Collector Cutoff Current	I_{CES}	$V_{CE} = 25\text{V}$, $I_B = 0$	-	-	1.0	μA
	I_{CBO}	$V_{CB} = 30\text{V}$, $I_E = 0$	-	-	50	nA
Emitter Cutoff Current	I_{EBO}	$V_{CB} = 30\text{V}$, $I_E = 0$	-	-	50	nA

Note 1. Pulse test: Pulse Width $\leq 300\mu\text{s}$, Duty Cycle $\leq 2\%$.

Electrical Characteristics (Cont'd): ($T_C = +25^\circ\text{C}$ unless otherwise specified)

Parameter	Symbol	Test Conditions	Min	Typ	Max	Unit
ON Characteristics						
DC Current Gain	h_{FE}	$I_C = 10\text{mA}, V_{CE} = 5\text{V}, \text{Note 1}$	20,000	-	200,000	-
		$I_C = 100\text{mA}, V_{CE} = 5\text{V}, \text{Note 1}$	30,000	-	300,000	-
		$I_C = 500\text{mA}, V_{CE} = 5\text{V}, \text{Note 1}$	20,000	-	200,000	-
Collector-Emitter Saturation Voltage	$V_{CE(sat)}$	$I_C = 50\text{mA}, I_B = 0.5\text{mA}$	-	0.71	1.2	V
		$I_C = 500\text{mA}, I_B = 0.5\text{mA}$	-	0.9	1.5	V
Base-Emitter Saturation Voltage	$V_{BE(sat)}$	$I_C = 500\text{mA}, I_B = 0.5\text{mA}$	-	1.52	2.0	V
Base-Emitter On Voltage	$V_{BE(on)}$	$I_C = 50\text{mA}, V_{CE} = 5\text{V}$	-	1.24	1.75	V
Small-Signal Characteristics						
Output Capacitance	C_{obo}	$V_{CB} = 10\text{V}, I_E = 0, f = 1.0\text{ MHz}$	-	5.4	7.0	μF
Input Capacitance	C_{ibo}	$V_{EB} 1.0\text{V}, I_C = 0, f = 1.0\text{ MHz}$	-	10	15	μF
Input Impedance	h_{ie}	$I_C = 10\text{mA}, V_{CE} = 5\text{V}, f = 1\text{ kHz}$	100	-	2000	$\text{k}\Omega$
Small-Signal Current Gain	h_{fe}	$I_C = 10\text{mA}, V_{CE} = 5\text{V}, f = 1\text{ kHz}$	20,000	-	-	-
Current Gain - High Frequency	$ h_{fe} $	$I_C = 10\text{mA}, V_{CE} = 5\text{V}, f = 100\text{ kHz}$	1.5	2.4	-	-
Output Admittance	h_{oe}	$I_C = 10\text{mA}, V_{CE} = 5\text{V}, f = 1\text{ kHz}$	-	-	1000	μhos
Noise Figure	NF	$I_C = 10\text{mA}, V_{CE} = 5\text{V}, f = 1\text{ kHz}, R_S = 100\text{ k}\Omega$	-	3.0	10	dB

Note 1. Pulse test: Pulse Width $\leq 300\mu\text{s}$, Duty Cycle $\leq 2\%$.

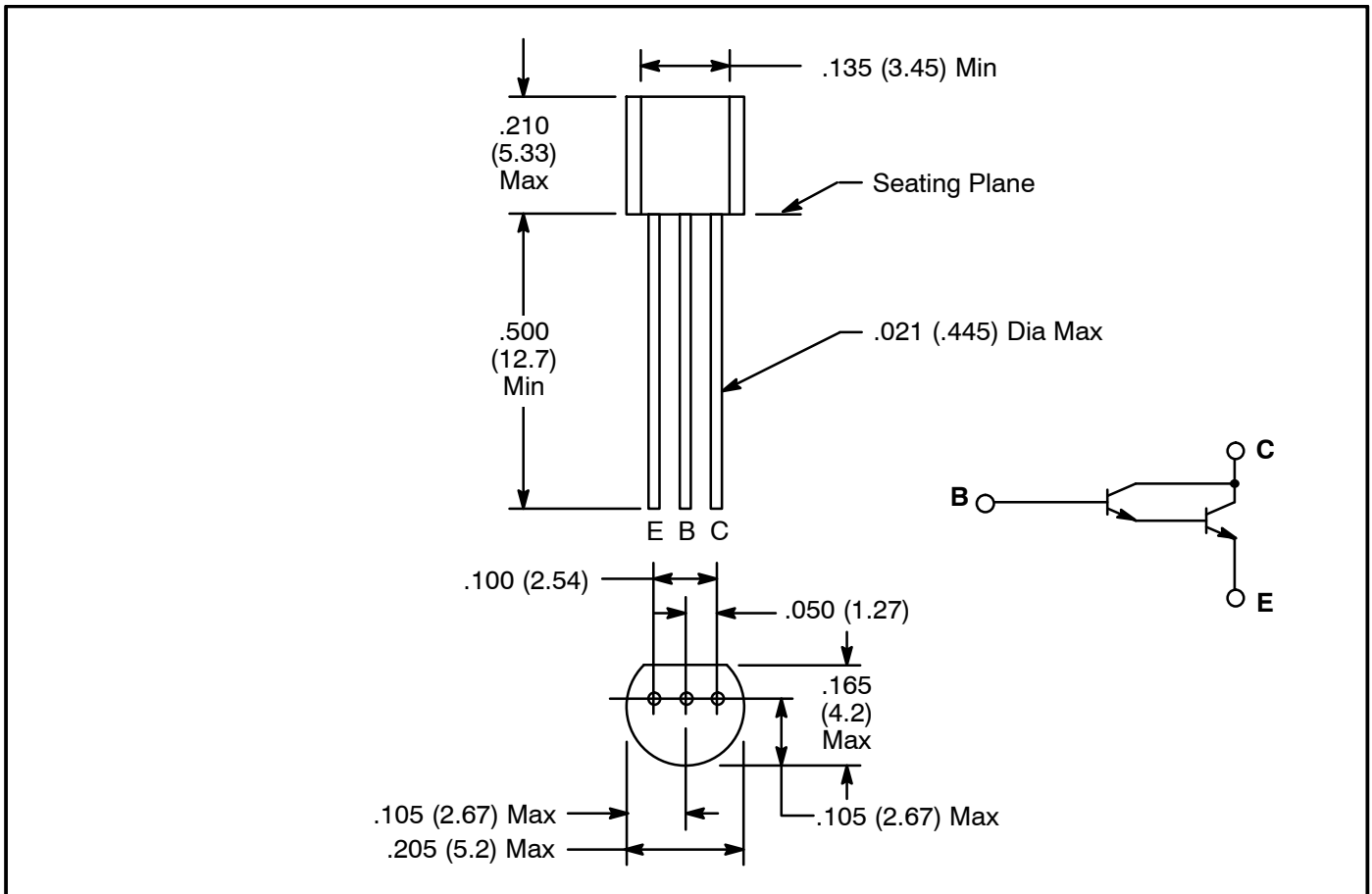

Looking for pricing, stock, or lifecycle information?

Click below to explore more details on WIN SOURCE:

 [View 2N6426 on WIN SOURCE](#)

 [NTE Information](#)

Optimize Your Supply Chain with WIN SOURCE Solutions

-  Global Sourcing Solution
-  Obsolete Management
-  Cost Control Management
-  Shortage Management
-  Alternative Solution
-  Excess Inventory Management