

Power Management

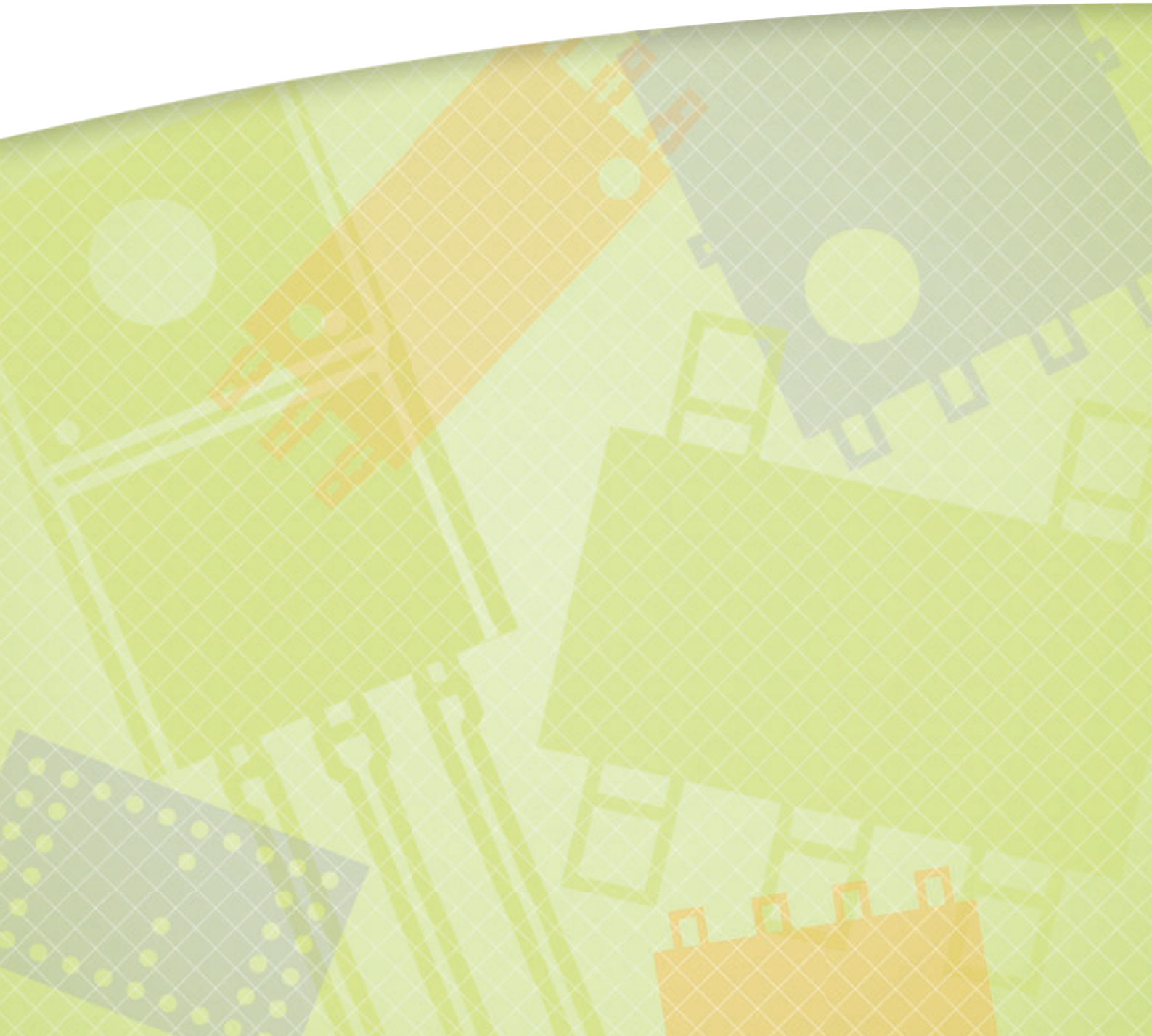

Toshiba offers various semiconductor devices for power supply applications to meet a wide range of customer needs varying from low power to high power. These devices help to save energy and improve power efficiency.



Contents

Switching Power Supplies	4	Photocouplers	21
AC-DC Flyback Power Supplies.....	4	Transistor-Output Photocouplers.....	21
AC-DC Forward Power Supplies.....	5	Diodes	22
AC-DC Half-Bridge Power Supplies.....	6	Schottky Barrier Diodes (SBDs) for Power Factor Correction (PFC)	
AC-DC Full-Bridge Power Supplies.....	7	Applications.....	22
Non-isolated DC-DC Converters.....	8	Schottky Barrier Diodes (SBDs) and	
Isolated DC-DC Converters.....	9	High-Efficiency Diodes (HEDs).....	23
Linear Power Supplies	10	Bipolar Power Transistors	24
CMOS Low-Dropout (LDO) Regulators.....	10	Switching Power Transistors.....	24
Load Switch ICs.....	12	Power Transistors for MOS Gate Drivers	
Power Multiplexer ICs.....	13	(for High-Speed Gate Drive of MOS Devices).....	24
Power Supplies by Application	14	Bipolar Power Transistors for self-Excited DC-DC Converter	
Wireless Power Transfer.....	14	Applications.....	24
LCD TVs.....	15	DC-DC Converter ICs	25
Server Power Supplies.....	16	PFC Control ICs.....	25
Solar Inverters (Power Conditioning Subsystems (PCS)).....	17	Multiple-Output DC-DC Converter ICs.....	26
Power MOSFETs	18	Rechargeable Lithium-Ion Battery Charger.....	26
Power MOSFETs for PFC Control and Switching Applications.....	18	Web Simulator	27
Synchronous Rectification MOSFETs.....	19		
Low-Voltage MOSFETs for			
DC-DC Converter Applications ($V_{bss} = 30$ to 250 V).....	20		

* Toshiba's schottky barrier diodes are silicon-based devices

Types and Applications of Switching Power Supplies

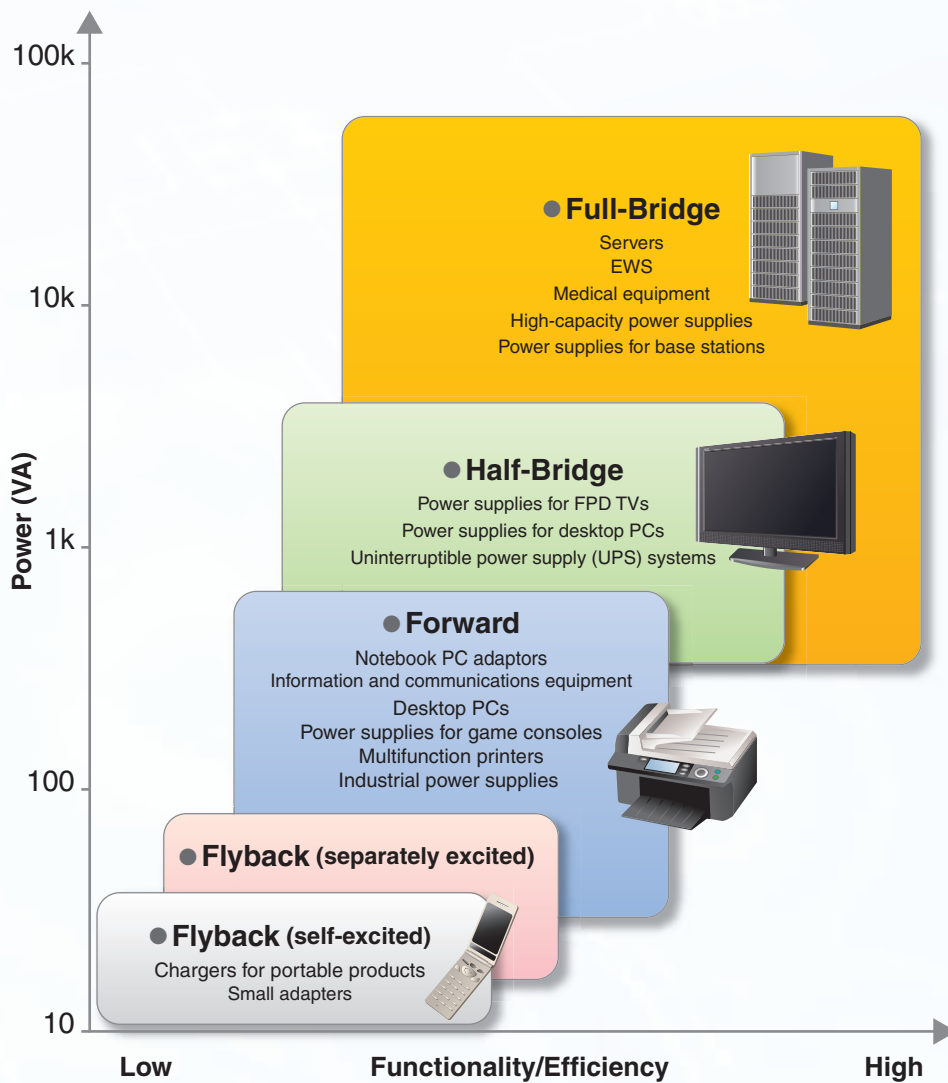

Types of DC-DC converters embedded in various power supplies

1. Non-Isolated
2. Isolated

Switching Power Supplies

AC-DC Flyback Power Supplies

Features

- AC-DC flyback power supplies have a very simple circuit configuration that consists of a minimal part count. They are suitable for low-power power supplies.

Application Examples

- Notebook PC adaptors
- Power supplies
- PC peripherals
- LCD adaptors
- Chargers for portable products
- Standby power supplies and small adaptors

Circuit Example

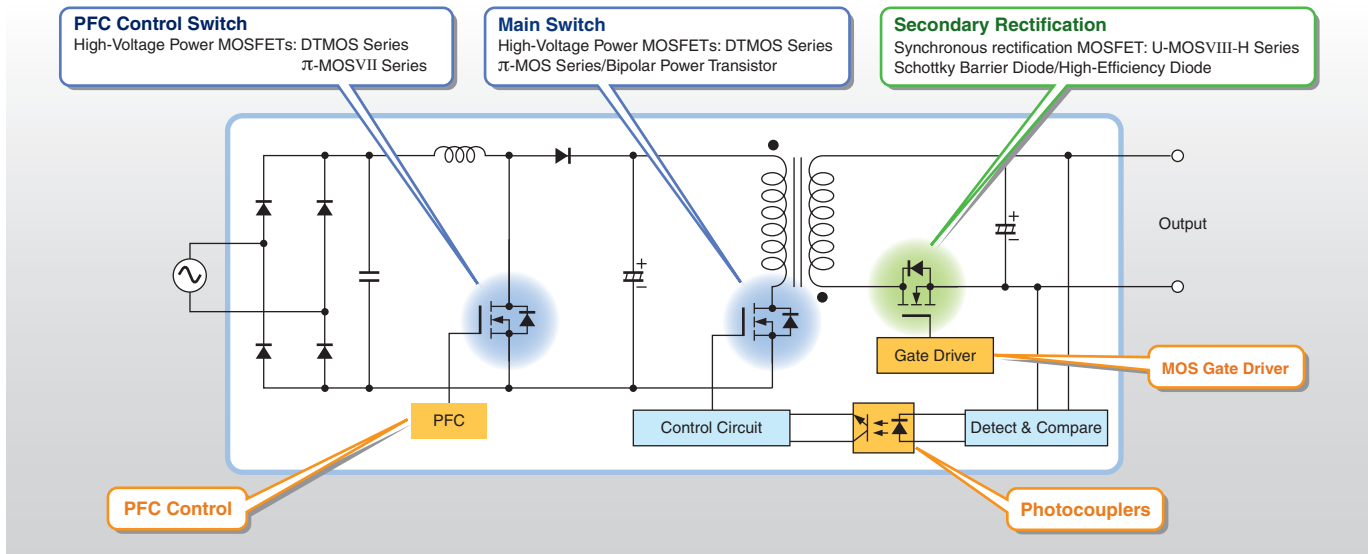

Recommended Parts

Output Power (W)			Up to 10	Up to 20	Up to 50	Up to 100	
PFC Control	PFC Controller ICs		TB6819AFG				
PFC Control Switch	High-Voltage Power MOSFETs	$V_{DSS} = 500\text{ V}$	TK5P50D, TK4A50D	TK5A50D, TK7P50D	TK8A50D, TK10A50D	TK12A50D, TK13A50D	
		$V_{DSS} = 600\text{ V}$	TK5A60W, TK5P60W	TK7A60W, TK7P60W	TK8A60W, TK8P60W TK10A60W, TK10P60W	TK12A60W, TK12P60W TK16A60W	
Main Switch	High-Voltage Power MOSFETs	$V_{DSS} = 600\text{ V}$	TK2P60D, TK2Q60D TK5P60W, TK5Q60W	TK4A60D, TK4P60D TK5P60W, TK5Q60W	TK7A60W, TK7P60W TK8A60W, TK8P60W	TK10A60W, TK10P60W TK12A60W, TK12P60W	
		$V_{DSS} = 650\text{ V}$	TK3A65D TK5A65W, TK5P65W	TK8A65D TK7A65W, TK7P65W	TK11A65D TK11A65W, TK11P65W	TK13A65D TK14A65W, TK17A65W	
		$V_{DSS} = 800\text{ to }900\text{ V}$	TK3P80E TK2P90E	TK6A80E, TK7A90E TK6P80W**, TK6Q80W**	TK10A80E, TK9A90E TK12A80W**, TK12E80W**	TK17A80W TK17E80W**	
	Bipolar Power Transistor	100-Vac input	2SC5548A, TTC008				
	200-Vac input	2SC6142, TTC012					
Secondary Rectification	Schottky Barrier Diode/ High-Efficiency Diode	Output: Up to 3 V ($V_{RRM} = 30\text{ V}$)	CUS10I30A, CRS10I30A CRS10I30C	CRS20I30A, CRS20I30B CMS20I30A	CRS30I30A, CMS30I30A		
		Output: Up to 5 V ($V_{RRM} = 40\text{ V}$)	CUS10I40A, CRS10I40A CRS10I40B	CRS20I40A, CRS20I40B CMS20I40A	CMS30I40A		
		Output: Up to 12 V ($V_{RRM} = 60\text{ V}$)	CUS04, CRS12 CRS13	CMS14			
		Output: Up to 24 V ($V_{RRM} = 200\text{ V}$)	CRH01, CMH04 CMH07	CMH01			
	Synchronous Rectification MOSFET (Low-Voltage Power MOSFETs)	$V_{DSS} = 60\text{ V}$	TPN11006NL TPH11006NL				
	$V_{DSS} = 100\text{ V}$			TK22A10N1, TK34A10N1 TK22E10N1, TK34E10N1	TK40A10N1, TK65A10N1 TK40E10N1, TK65E10N1 TK65G10N1		
	$V_{DSS} = 120\text{ V}$			TK32A12N1, TK42A12N1 TK32E12N1, TK42E12N1	TK56A12N1, TK72A12N1 TK56E12N1, TK72E12N1		
MOS Gate Driver	Bipolar Power Transistor		TPCP8901, TPCP8902				
Output Error Feedback	Photocouplers	Analog feedback	TLP183, TLP293, TLP383, TLP385				
		Digital feedback	TLP2309, TLP2355, TLP2358				

** : Under development

AC-DC Forward Power Supplies

Features

- AC-DC forward power supplies with a relatively simple circuit configuration are widely used for 100-W to 500-W power supply applications. Forward power supplies have less ripple since the capacitor is continuously charged. Compared to flyback power supplies, they exhibit a higher transformer efficiency and thus can provide up to 500 W.

Application Examples

- Notebook PC adaptors
- Desktop PCs
- Power supplies for game consoles
- Information and communications equipment
- Multifunction printers
- Industrial power supplies

Circuit Example

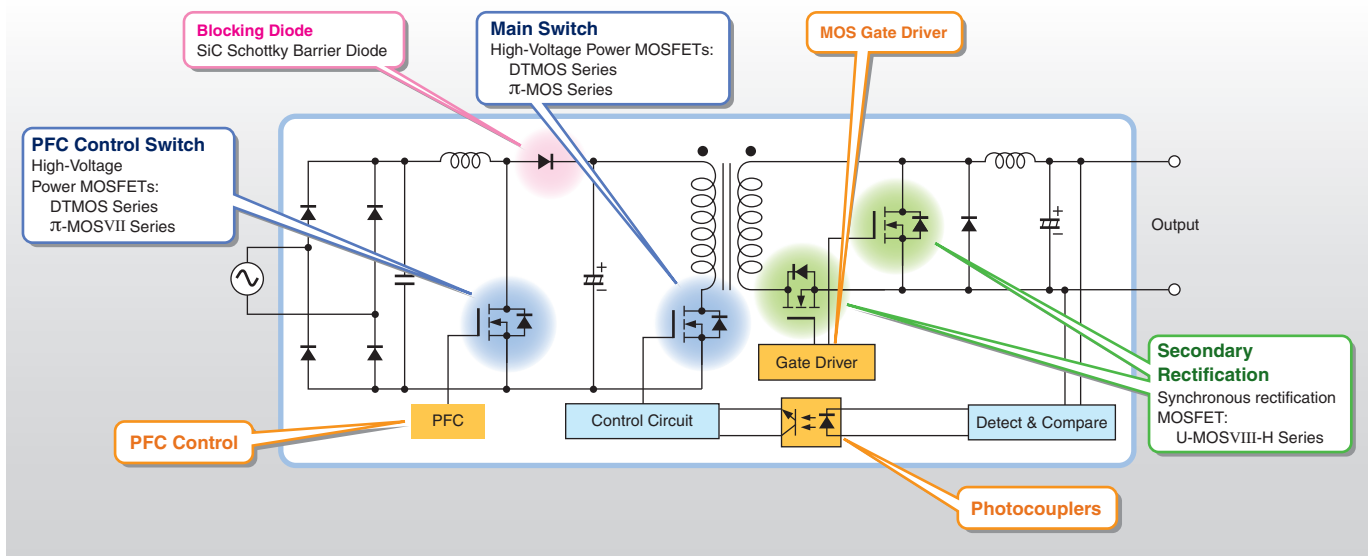

Recommended Parts

Output Power (W)			Up to 100	Up to 150	Up to 200
PFC Control	PFC Controller ICs		TB6819AFG		
PFC Control Switch	High-Voltage Power MOSFETs	$V_{DSS} = 500\text{ V}$	TK5P50D, TK4A50D	TK7P50D, TK5A50D	TK8A50D, TK10A50D
		$V_{DSS} = 600\text{ V}$	TK16A60W, TK16E60W TK20A60W, TK20E60W	TK20A60W, TK25A60X TK20E60W, TK25E60X	TK31A60W, TK31E60X TK31N60X, TK39A60W
Blocking Diode	SiC Schottky Barrier Diode	$V_{RRM} = 650\text{ V}$	TRS6A65C, TRS6E65C	TRS8A65C, TRS8E65C	TRS10A65C, TRS12A65C TRS10E65C, TRS12E65C
Main Switch	High-Voltage Power MOSFETs	$V_{DSS} = 600\text{ V}$	TK10A60W, TK12A60W TK12V60W	TK16A60W, TK20A60W TK16V60W, TK20V60W	TK25A60X, TK31A60W TK25V60X, TK31V60W
		$V_{DSS} = 650\text{ V}$	TK11A65W, TK14A65W TK14V65W**	TK17A65W, TK17V65W**	TK28A65W, TK28V65W**
Secondary Rectification	Synchronous Rectification MOSFET (Low-Voltage Power MOSFETs)	$V_{DSS} = 60\text{ V}$	TK30A06N1, TK30E06N1 TPH11006NL, TPN11006NL TPH14006NH, TPN14006NH	TK40A06N1, TK40E06N1 TPH7R506NH, TPN7R506NH	TK58A06N1, TK58E06N1 TPH4R606NH
		$V_{DSS} = 80\text{ V}$	TK35A08N1, TK35E08N1 TPH12008NH, TPN13008NH	TK46A08N, TK46E08N TPH8R008NH	TK72A08N1, TK72E08N1 TPH4R008NH
		$V_{DSS} = 100\text{ V}$	TK34A10N1, TK34E10N1 TPH1400ANH, TPN1600ANH	TK40A10N1, TK40E10N1 TPH8R80ANH	TK65A10N1, TK65E10N1 TK65G10N1, TPH4R50ANH
		$V_{DSS} = 120\text{ V}$	TK32A12N1, TK32E12N1	TK42A12N1, TK42E12N1	TK56A12N1, TK56E12N1
MOS Gate Driver	Bipolar Power Transistor		TPCP8901, TPCP8902		
Output Error Feedback	Photocouplers	Analog feedback	TLP183, TLP293, TLP383, TLP385		
		Digital feedback	TLP2309, TLP2355, TLP2358		

** : Under development

Switching Power Supplies

AC-DC Half-Bridge Power Supplies

Features

- Resonant half-bridge power supplies are suitable for relatively high-power power supply applications in the range of 150 W to 1 kW. The two transistors connected in series with the input supply voltage reduce the input voltage applied to the primary side of the transformer by half. This makes it possible to use Low-Voltage transistors.

Application Examples

- Power supplies for FPD TVs
- Uninterruptible power supplies (UPS)
- Desktop PCs
- Servers

Circuit Example

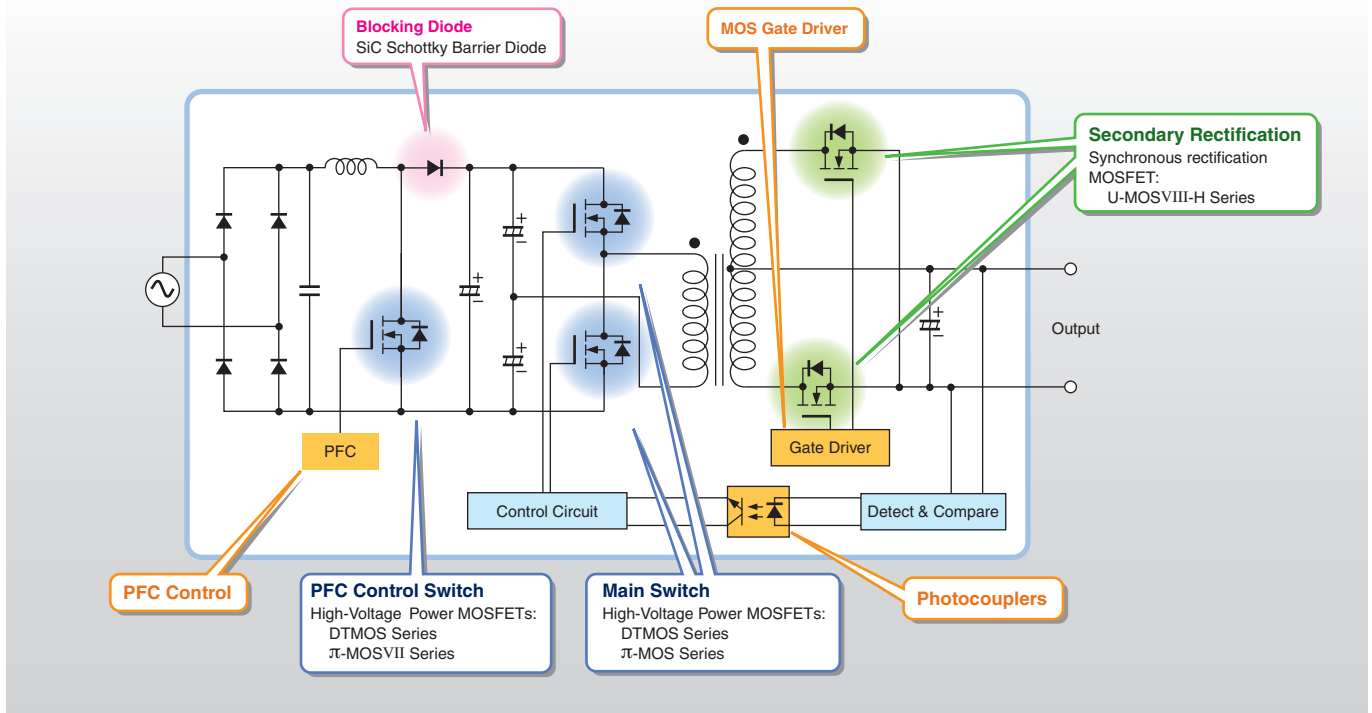

Recommended Parts

Output Power (W)			Up to 100	Up to 200	Up to 400	Up to 800
PFC Control	PFC Controller ICs		TB6819AFG		TB6818FG	
PFC Control Switch	High-Voltage Power MOSFETs	$V_{DSS} = 500\text{ V}$	TK13A50D TK15A50D	TK18A50D, TK15J50D TK20J50D	TK20J50D	
		$V_{DSS} = 600\text{ V}$	TK16A60W, TK16E60W TK20A60W, TK20E60W	TK31A60W, TK31E60X TK31N60X, TK39A60W	TK39N60X, TK62N60X	TK62N60X, TK100L60W
Blocking Diode	SIC Schottky Barrier Diode	$V_{RRM} = 650\text{ V}$	TRS6A65C, TRS6E65C	TRS10A65C, TRS12A65C TRS12E65C, TRS12N65D	TRS12N65D, TRS16N65D TRS20N65D	TRS20N65D, TRS24N65D
Main Switch	High-Voltage Power MOSFETs	$V_{DSS} = 600\text{ V}$	TK8A60W5, TK10A60W5	TK16A60W5, TK20A60W5	TK20N60W5, TK25A60X5 TK31V60W5	TK31N60W5, TK39N60W5 TK62N60W5
		$V_{DSS} = 650\text{ V}$	TK14A65W5, TK14E65W5	TK14A65W5, TK17A65W5	TK28N65W5, TK35N65W5	TK35N65W5, TK49N65W5
Secondary Rectification	Synchronous Rectification MOSFET (Low-Voltage Power MOSFETs)	$V_{DSS} = 40\text{ V}$			TPH1R204PL7	TPHR8504PL
		$V_{DSS} = 45\text{ V}$				TPH1R005PL
		$V_{DSS} = 60\text{ V}$	TK30A06N1, TK30E06N1 TPH11006NL, TPN11006NL TPH14006NH, TPN14006NH	TK40A06N1, TK40E06N1 TPH7R506NH, TPN7R506NH	TK58A06N1, TK58E06N1 TPH4R606NH	TK100A06N1, TK100E06N1 TPH2R306NH
		$V_{DSS} = 80\text{ V}$	TK35A08N1, TK35E08N1 TPH12008NH, TPN13008NH	TK46A08N, TK46E08N TPH8R008NH	TK72A08N1, TK72E08N1 TPH4R008NH	TK100A08N1, TK100E08N1 TPH4R008NH (2parallel) TPW4R008NH
		$V_{DSS} = 100\text{ V}$	TK34A10N1, TK34E10N1 TPH1400ANH, TPN1600ANH	TK40A10N1, TK40E10N1 TPH8R80ANH	TK65A10N1, TK65E10N1 TK65G10N1, TPH4R50ANH	TK100A10N1, TK100E10N1 TPH4R50ANH (2parallel) TPW4R50ANH
		$V_{DSS} = 120\text{ V}$	TK32A12N1, TK32E12N1	TK42A12N1, TK42E12N1	TK56A12N1, TK56E12N1	TK72A12N1, TK72E12N1
MOS Gate Driver	Bipolar Power Transistor		TPCP8901, TPCP8902			
Output Error Feedback	Photocouplers	Analog feedback	TLP183, TLP293, TLP383, TLP385			
		Digital feedback	TLP2309, TLP2355, TLP2358			

AC-DC Full-Bridge Power Supplies

Features

Full-bridge circuits are more complex than half-bridge circuits. However, since full-bridge power supplies provide higher efficiency, they are mainly used for large-capacity applications (with over 1-kW capacity).

- Because full-bridge power supplies evenly energize transformers bidirectionally, they do not cause magnetization in transformers. Thus, full-bridge power supplies do not need a demagnetization circuit.
- While the frequency and current ranges of a half-bridge power supply are limited by the capacitor used, full-bridge power supplies are free from this limit. Therefore, full-bridge power supplies can be used for relatively low-frequency, high-current applications.
- Because diodes in a full-bridge power supply form a current return circuit, it generates less noise than a half-bridge power supply.

Application Examples

- Power supplies for base stations
- EWS
- High-capacity power supplies
- Servers
- Medical equipment

Circuit Example

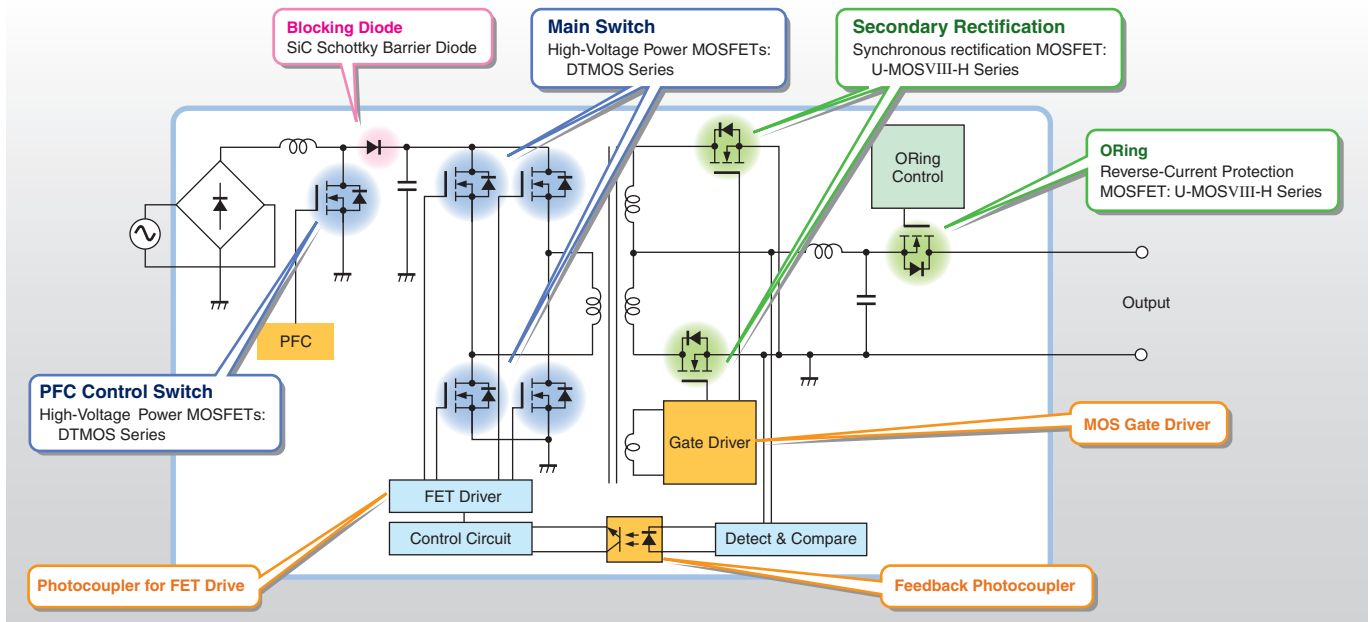

Recommended Parts

		Output Power (kW)	Up to 1	Up to 2	Up to 3
PFC Control	PFC Controller ICs			TB6818FG	
PFC Control Switch	High-Voltage Power MOSFETs	$V_{DSS} = 600\text{ V}$	TK31N60X, TK39N60X TK62N60X	TK39N60X, TK62N60X TK100L60W	TK62N60X TK100L60W
Blocking Diode	SiC Schottky Barrier Diode	$V_{RRM} = 650\text{ V}$	TRS16N65D, TRS20N65D TRS24N65D	TRS20N65D TRS24N65D	TRS24N65D
Main Switch	High-Voltage Power MOSFETs	$V_{DSS} = 600\text{ V}$	TK31N60W5, TK39N60W5	TK39N60W5 TK62N60W5	TK62N60W5
		$V_{DSS} = 650\text{ V}$	TK28N65W5, TK35N65W5	TK35N65W5 TK49N65W5	TK49N65W5
Secondary Rectification	Synchronous Rectification MOSFET (Low-Voltage Power MOSFETs)	$V_{DSS} = 40\text{ V}$	TPHR8504PL	TPWR8004PL	TPWR8004PL (2parallel)
		$V_{DSS} = 45\text{ V}$	TPH1R005PL	TPH1R005PL (2parallel)	TPH1R005PL (3parallel)
		$V_{DSS} = 60\text{ V}$	TK100A06N1 TK100E06N1 TPH2R306NH	TK100A06N1 (2parallel) TK100E06N1 (2parallel) TPH2R306NH (2parallel)	TK100A06N1 (4parallel) TK100E06N1 (4parallel) TPH2R306NH (4parallel)
		$V_{DSS} = 75\text{ V}$	TPH2R608NH	TPH2R608NHL (2parallel)	TPH2R608NH (4parallel)
		$V_{DSS} = 80\text{ V}$	TK100A08N1 TK100E08N1 TPH4R008NH (2parallel)	TK100A08N1 (2parallel) TK100E08N1 (2parallel) TPH4R008NH (4parallel)	TK100A08N1 (4parallel) TK100E08N1 (4parallel) TPW4R008NH (4parallel)
		$V_{DSS} = 100\text{ V}$	TK100A10N1 TK100E10N1 TPH4R50ANH (2parallel)	TK100A10N1 (2parallel) TK100E10N1 (2parallel) TPH4R50ANH (4parallel)	TK100A10N1 (4parallel) TK100E10N1 (4parallel) TPW4R50ANH (4parallel)
		$V_{DSS} = 120\text{ V}$	TK72A12N1 TK72E12N1	TK72A12N1 (2parallel) TK72E12N1 (2parallel)	TK72A12N1 (4parallel) TK72E12N1 (4parallel)
MOS Gate Driver	Bipolar Power Transistor		TPCP8901, TPCP8902		
MOSFET Gate Driver	Photocouplers	1.0 to 2.5 A Output		TLP5751, TLP5752	
Output Error Feedback	Photocouplers	Analog feedback		TLP183, TLP293, TLP383, TLP385	
		Digital feedback		TLP2309, TLP2355, TLP2358	
ORing	Reverse-Current Protection MOSFET	$V_{DSS} = 30\text{ V}$	TPHR9003NL (2parallel) TPWR8503NL (2parallel)	TPHR9003NL (4parallel) TPWR8503NL (3parallel)	TPHR9003NL (6parallel) TPWR8503NL (4parallel)
		$V_{DSS} = 60\text{ V}$	TPH2R306NH (2parallel)	TPH2R306NH (4parallel)	TPH2R306NH (6parallel)

Switching Power Supplies

▶ Non-isolated DC-DC Converters

● Features

A DC-DC converter is an electronic circuit which converts a direct current from one voltage level to another. While non-isolated DC-DC converters are primarily used for applications requiring less than 30 W, up to 100 W can be handled by adding a single MOSFET. Many DC-DC converters are deployed in mobile devices and many other equipments that are becoming smaller, lighter and more feature-rich.

● Application Examples

- POL modules
- On-board DC-DC converters
- CPU and memory power supplies

● Circuit Example

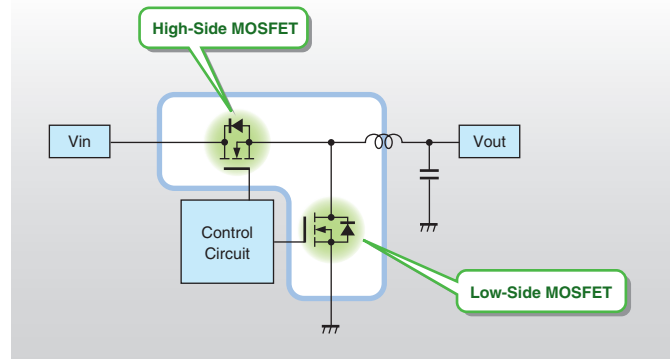

● Recommended Parts

Input-to-Output Voltage Ratio*	Output Current (A)	Up to 10	Up to 15	Up to 20	Up to 25	Up to 30	Up to 40
Up to 0.08	High Side	TPCC8066-H	TPCC8066-H TPN11003NL	TPN11003NL TPCC8065-H	TPCC8065-H TPN8R903NL	TPN8R903NL TPN6R003NL	TPN6R003NL TPH6R003NL
	Low Side	TPN8R903NL	TPN6R003NL	TPN4R303NL TPCA8059-H TPH6R003NL	TPN4R303NL TPCA8057-H	TPN2R703NL TPH3R203NL TPCA8055-H	TPH1R403NL
Up to 0.15	High Side	TPCC8066-H TPN11003NL	TPN11003NL TPCC8065-H	TPCC8065-H TPCA8065-H TPN8R903NL	TPN8R903NL TPN6R003NL	TPN6R003NL	TPN6R003NL TPH6R003NL TPN4R303NL TPH4R003NL
	Low Side	TPCC8065-H TPN8R903NL	TPN6R003NL	TPN4R303NL TPCA8059-H TPN6R003NL	TPN4R303NL TPCA8057-H	TPN2R703NL TPH3R203NL TPCA8055-H	TPH1R403NL
Up to 0.5	High Side	TPCC8065-H TPN8R903NL	TPN8R903NL TPN6R003NL	TPN4R303NL TPCA8059-H TPN6R003NL	TPN4R303NL TPCA8057-H		
	Low Side	TPCC8065-H TPN8R903NL	TPN6R003NL	TPN4R303NL TPCA8059-H TPN6R003NL	TPN4R303NL TPCA8057-H		

* Input-to-Output Voltage Ratio: output_voltage / input_voltage

● MOSFET Selection

The optimal pair of a high-side and a low-side MOSFET depends on the required output current.

The figure at right shows examples of efficiency curves when the input is at 19 V and the output is at 3.3 V (input-to-output voltage ratio = 0.17). Notice that, at up to 4 A, using the TPH8R903NL for both low and high sides delivers higher efficiency than using the TPH8R903NL/TPH6R003NL pair, and that at higher than 4 A, using the TPH8R903NL/TPH6R003NL pair as the high-side and low-side MOSFETs provides higher efficiency. The above table gives examples of recommended MOSFET pairs according to the output current requirement.

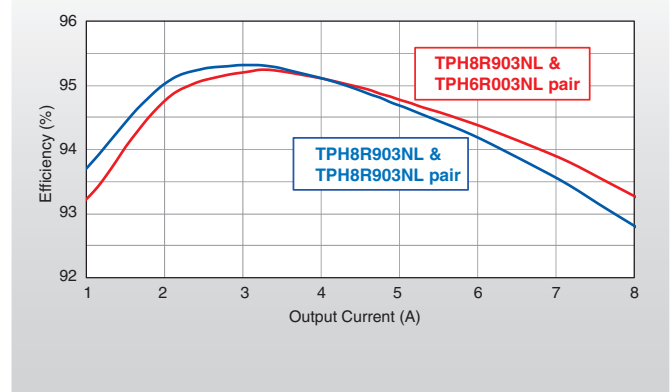

Isolated DC-DC Converters

Features

Isolated DC-DC converters are widely used for applications in which there is a large difference between input and output voltages. Isolated half-bridge and full-bridge converters can handle up to 1 kW or so. Isolated DC-DC converters are used in power supplies for cell sites where direct-current distribution is utilized. They are used for both step-down and step-up voltage conversion.

Application Examples

- DC-DC converters for communication applications
- Regulated power supplies

Half-Bridge

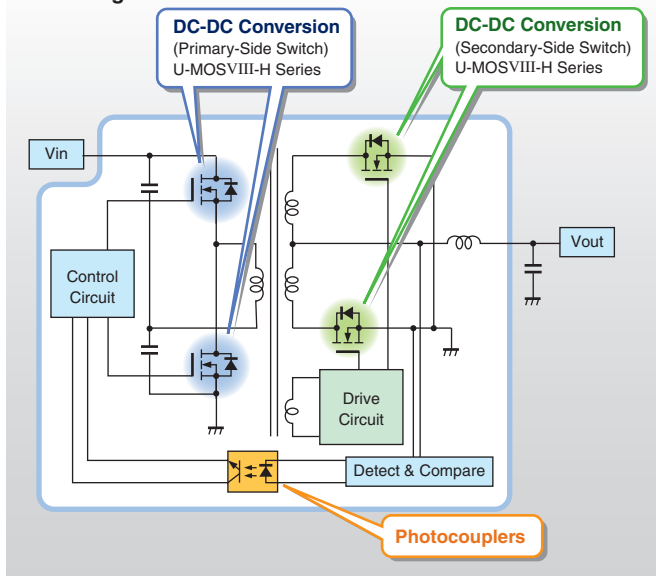

Forward: Up to 200 W

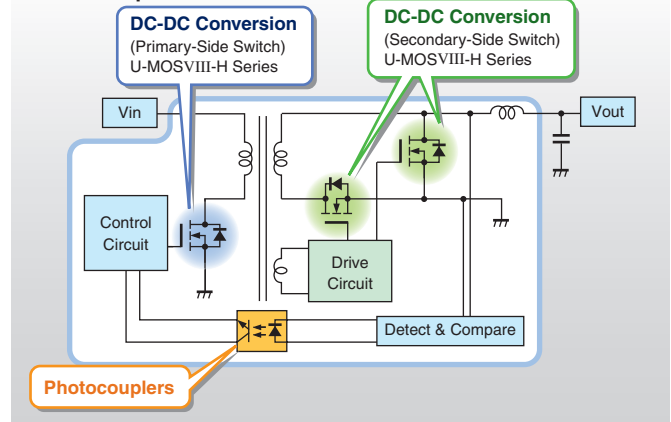

Full-Bridge: Up to 1 kW

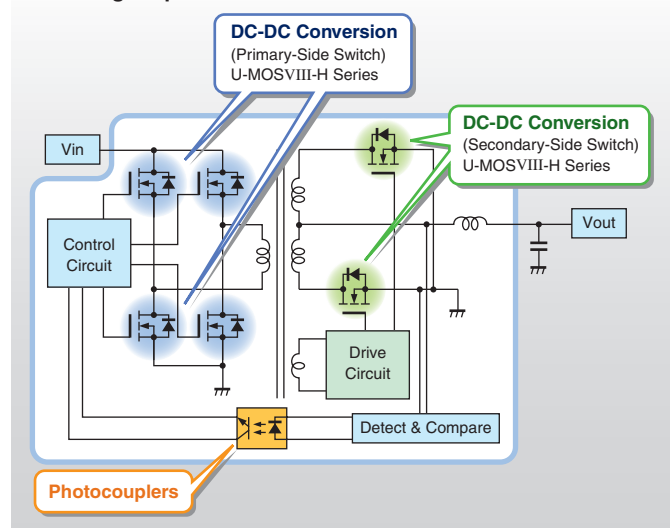

Recommended Parts

Output Power (W)		Up to 50 Forward	Up to 150 Half-Bridge	Up to 300 Full-Bridge	Up to 500 Full-Bridge	Up to 1000 Full-Bridge	
DC-DC Conversion (Primary-Side Switch)	Low-Voltage Power MOSFETs	V _{DSS} = 60 V			TPH4R606NH	TPH2R306NH	TPH2R306NH (2parallel)
		V _{DSS} = 80 V			TPH8R008NH	TPH4R008NH	TPH4R008NH (2parallel)
		V _{DSS} = 100 V			TPH8R80ANH	TPH4R50ANH	TPH4R50ANH (2parallel)
		V _{DSS} = 150 V		TPN5900CNH TPH3300CNH			
		V _{DSS} = 200 V	TPN1110ENH TPH1110ENH	TPH6400ENH			
DC-DC Conversion (Secondary-Side Switch)	Low-Voltage Power MOSFETs	V _{DSS} = 250 V	TPH1110FNH				
		V _{DSS} = 30 V (V _{out} = 3.3 V)	TPN6R003NL TPN4R303NL	TPH1R403NL TPHR9003NL	TPHR9003NL (2parallel)	TPHR9003NL (4parallel)	TPHR9003NL (8parallel)
		V _{DSS} = 40 V (V _{out} = 5 V)			TPHR8504PL	TPHR8504PL (2parallel) TPWR8004PL	TPHR8504PL (4parallel) TPWR8004PL (3parallel)
		V _{DSS} = 45 V			TPH1R005PL	TPH1R005PL (2parallel)	TPH1R005PL (4parallel)
		V _{DSS} = 60 V (V _{out} = 12 V)	TPN22006NH	TPN14006NH TPN7R506NH	TPH5R906NH TPH4R606NH	TPH2R306NH	TPH2R306NH (2parallel)
		V _{DSS} = 75 V				TPH2R608NH	TPH2R608NH (2parallel)
		V _{DSS} = 80 V (V _{out} = 12 V)	TPN30008NH	TPN13008NH TPH8R008NH	TPH4R008NH	TPH4R008NH (2parallel) TPW4R008NH (2parallel)	TPH4R008NH (4parallel) TPW4R008NH (3parallel)
		V _{DSS} = 100 V (V _{out} = 12 V)	TPN3300ANH	TPN1600ANH TPH8R80ANH	TPH4R50ANH	TPH4R50ANH (2parallel) TPW4R50ANH (2parallel)	TPH4R50ANH (4parallel) TPW4R50ANH (3parallel)
		V _{DSS} = 150 V (V _{out} = 24 V)	TPN5900CNH TPH5900CNH	TPH3300CNH	TPH1500CNH	TPH1500CNH (2parallel)	TPH1500CNH (4parallel)
		V _{DSS} = 200 V (V _{out} = 36 V)	TPN1110ENH TPH1110ENH	TPH6400ENH	TPH2900ENH	TPH2900ENH (2parallel)	TPH2900ENH (4parallel)
		V _{DSS} = 250 V (V _{out} = 48 V)	TPN2010FNH TPH2010FNH	TPH1110ENH	TPH5200FNH	TPH5200FNH (2parallel)	TPH5200FNH (4parallel)
Output Error Feedback	Photocouplers	Analog feedback	TLP183, TLP293, TLP383, TLP385				
		Digital feedback	TLP2309, TLP2355, TLP2358				

Detailed information about our MOSFETs is available on our website: <http://toshiba.semicon-storage.com/>

Linear Power Supplies

Toshiba offers a wide selection of linear power supplies designed for various purposes, including CMOS low-dropout (LDO) regulators that remove ripples and provide a constant DC voltage, load switch ICs that conduct and shut off power supplies as necessary to reduce system power consumption, and power multiplexer ICs that simplify control of multiple charging channels.

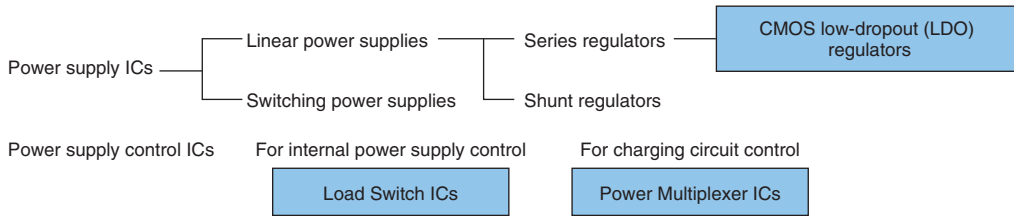

CMOS Low-Dropout (LDO) Regulators

Features

Linear power supplies are available in a wide range of packages from general-purpose SMV (SOT-25) to an ultra-small package with the industry's smallest form factor measuring 0.8×0.8 mm. Those in the DFN5B, DFN4, SDFN4 and WCSP4 packages, which are most widely used for small portable applications, are offered with various current/voltage ratings and additional features.

Additionally, the new LDO regulator series provides a significant reduction in voltage dropout thanks to reduced process geometries.

Application Examples

- Small portable devices
(Smartphones, Portable audio, Notebook PCs, Digital still camera, Digital video camera)

Circuit Example

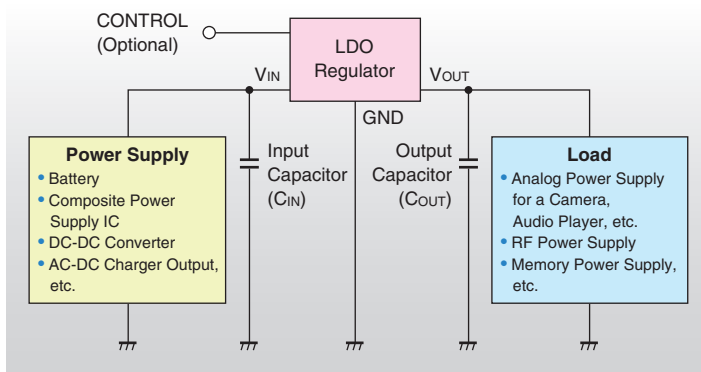

Reduced Voltage Dropout Because of the Use of a New Process (Example: TCR2EN12 1.2-V output LDO regulator)

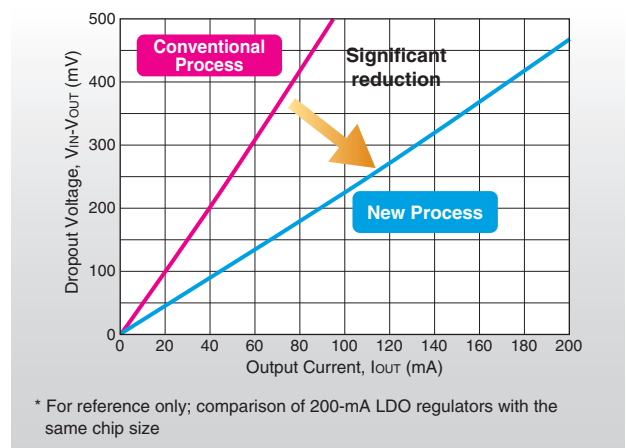

Recommended Parts

Series	Output Current (mA)	Output Voltage (V)	Features	Overcurrent Protection	Thermal Shutdown	Automatic Output Discharge	Package
TCR2DG	200	1.2 to 3.6	Low noise High ripple rejection ratio	✓	✓	✓	WCSP4
TCR2EN	200	1.0 to 3.6	Standard type	✓		✓	SDNF4
TCR2EE		1.0 to 5.0		✓		✓	ESV
TCR2EF		1.0 to 5.0		✓		✓	SMV
TCR2LN	200	0.8 to 3.6	Low power consumption	✓		✓	SDNF4
TCR2LE				✓		✓	ESV
TCR2LF				✓		✓	SMV
TCR3DM	300	1.0 to 4.5	Low dropout voltage Low inrush current	✓	✓	✓	DFN4
TCR3DF				✓	✓	✓	SMV
TCR5AM	500	0.55 to 3.6	Low-voltage output Low dropout voltage	✓	✓	✓	DFN5B

Packages

SMV SOT-25 (2.8 x 2.9)	ESV SOT-553 (1.6 x 1.6)	DFN5B (1.2 x 1.2)	DFN4 (1.0 x 1.0)	SDFN4 (0.8 x 0.8)	WCSP4 (0.79 x 0.79)

* The unit of measure for values enclosed between parentheses is mm.

TCR5AM Series

The TCR5AM Series of 500-mA LDO regulators provide low dropout voltage in the low-input-voltage region and thus help improve power efficiency.

Features

- Low output voltage: 0.55 V to 3.6 V
- Low dropout voltage: 90 mV (typ.)
@ $V_{OUT} = 1.0\text{ V}$, $V_{BAT} = 3.3\text{ V}$,
 $I_{OUT} = 300\text{ mA}$
- Low current consumption: 35 μA (typ.)

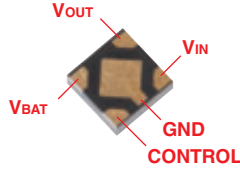

With voltage applied to the external bias power supply terminal (V_{BAT}), the TCR5AM Series provides low dropout voltage. V_{BAT} consumes a low current of 35 μA (typ.).

- Protection circuits
Overcurrent protection (OCP), thermal shutdown (TSD), undervoltage lockout (UVLO)

Recommended Circuit

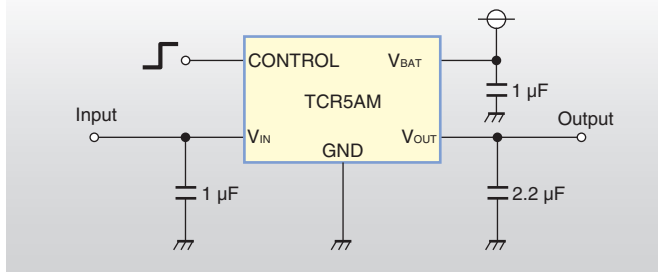

Dropout Voltage

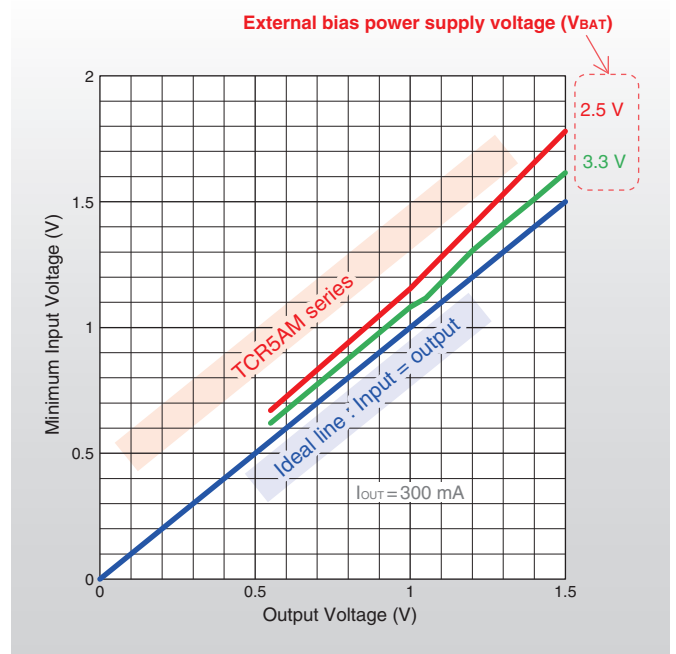

TCR2L Series

The low current consumption of the TCR2L Series makes it ideal for reducing the power consumption of applications that remain in standby mode for long periods of time such as near-field communication (NFC) devices.

Features

- Low bias current: 2 μA max
(over the entire operating temperature range)
- Output Current I_{OUT} (DC) = 200 mA

Current Consumption

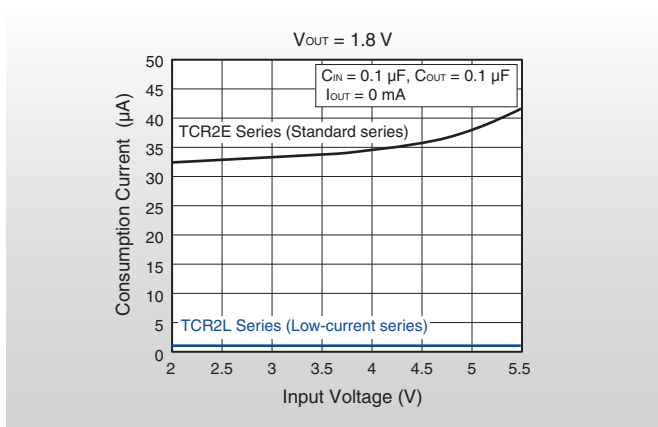

Key Characteristics

- Output Voltage: 0.8 V to 3.6 V (in steps of 50 mV)
- Dropout Voltage: 200 mV (typ.) @ $V_{OUT} = 3.3\text{ V}$,
 $I_{OUT} = 150\text{ mA}$

Recommended Circuit

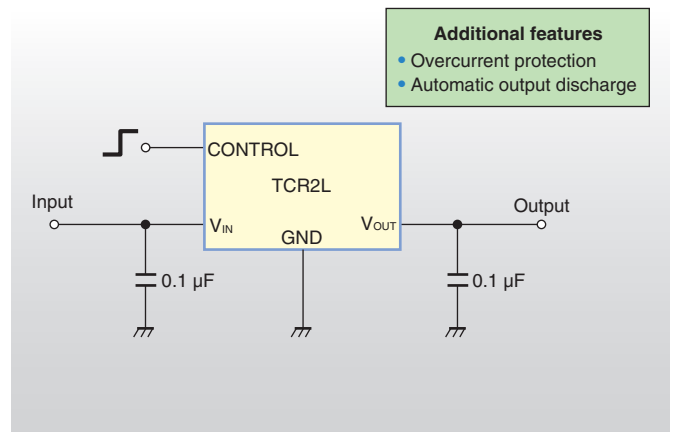

Load Switch ICs

Features

Load switch ICs control the supply of electric power to the downstream system loads. Their intended use is to shut off power supplies as their loads enter standby mode. Load switch ICs are power supply ICs fabricated using a CMOS process and contain an output transistor and an output driver. They provide a solution footprint much smaller than load switches composed of discrete components. Moreover, load switch ICs feature low-voltage operation, low on-resistance and low current consumption, and provide additional functions.

Application Examples

- Small portable devices (Smartphones, Portable audio, Notebook PCs, Digital still camera, Digital video camera)

Application Example: Power distribution control circuit

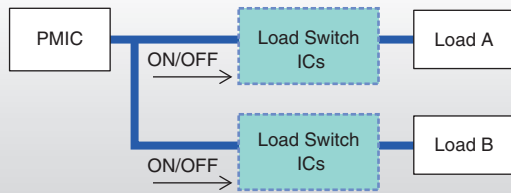

* Load switch ICs make it possible to selectively conduct and shut off power supplies to individual loads and provide automatic output discharge at shutdown. Thus, load switch ICs allow optimal power sequence control.

Example On-Resistance Curve

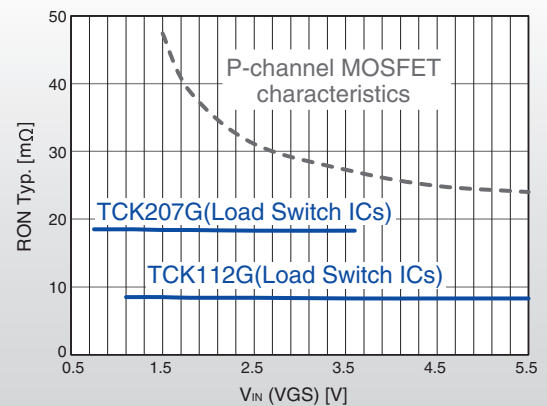

* A small-geometry process and an advanced circuit technology combine to deliver low on-resistance, contributing to a reduction of a system's power loss.

Application Example: Power source selection circuit

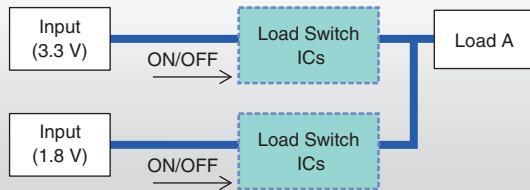

* The reverse-current protection feature of load switch ICs makes it possible to selectively use multiple power supplies for a given load.

Recommended Parts

Package (mm)	Part Number	Output Current (A)	Operating Voltage (V)	Inrush Current Limiting	Thermal Shutdown	Overcurrent Protection	Reverse-Current Protection	Automatic Output Discharge	Control Pin
WCSP6B (0812)	TCK101G	1	1.1 to 5.5	✓	✓			✓	Active High
	TCK102G	1		✓	✓				Active High
	TCK104G	0.5		✓	✓	✓		✓	Active High
	TCK105G	0.8		✓	✓	✓		✓	Active High
WCSP4 (0808)	TCK106G	1	1.1 to 5.5	✓					Active High
	TCK107G	1		✓				✓	Active High
	TCK108G	1		✓				✓	Active Low
WCSP6C (1015)	TCK111G	3	1.1 to 5.5	✓	✓		✓		Active High
	TCK112G	3		✓	✓		✓	✓	Active High
WCSP4C (0909)	TCK206G	2	0.75 to 3.6	✓			✓		Active High
	TCK207G	2		✓			✓	✓	Active High
	TCK208G	2		✓			✓	✓	Active Low

▶ Power Multiplexer ICs

● Features

Designed for mobile applications, power multiplexer ICs make it possible to select one of two power sources. As there is an increasing variety of charging specifications, power multiplexer ICs help simplify the control of multiple charging channels. Power multiplexer ICs can select a power source automatically or allow a mobile device to select one via an external signal. Thus, power multiplexer ICs help simplify the power supply design.

● Application Examples

- Small portable devices (Electronic devices that have two power supply inputs such as AC-adaptor and USB inputs)

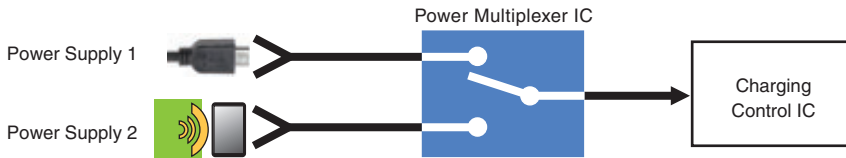

Auto Power Select Mode

● TCK321G/322G Timing Diagram

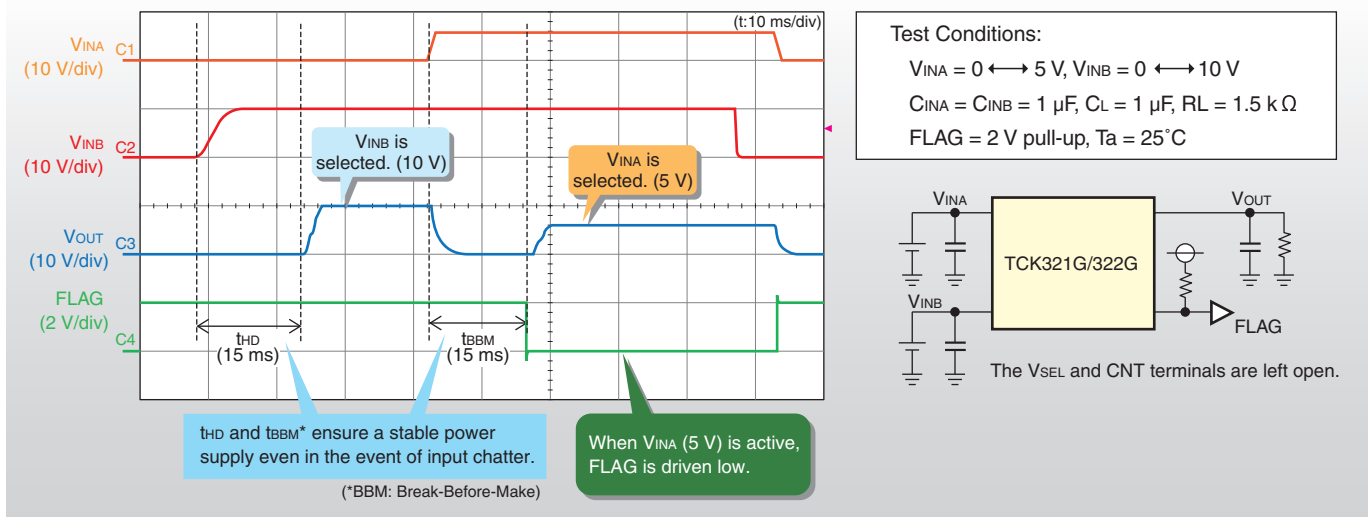

● Recommended Parts

Package (mm)	Switch Configuration	Part Number	Output Current (A)	Operating Voltage (V)	Overvoltage Detection, Typ. (V)	Undervoltage Protection, Typ. (V)	Thermal Shutdown	Reverse-Current Protection	Auto Power Select	Others
WCSP16C (1919)	Dual inputs - Single output	TCK321G	2.0	2.3 to 36	12	2.9	✓	✓	✓	FLAG: V_{INA} Monitor
		TCK322G	2.0		15	2.9	✓	✓	✓	FLAG: V_{INA} Monitor
		TCK323G	2.0		15	2.9	✓	✓	✓	FLAG: V_{INB} Monitor
WCSP9C (1515)	Single input - Single output	TCK301G	3.0	2.3 to 28	6.6	2.9	✓	✓	Daisy-chained	Control Active High
		TCK302G	3.0		10.5	2.9	✓	✓		Control Active High
		TCK303G	3.0		15.5	2.9	✓	✓		Control Active High
		TCK304G	3.0		6.6	2.9	✓	✓		Control Active Low
		TCK305G	3.0		15	2.9	✓	✓		Control Active Low

Power Supplies by Application

Wireless Power Transfer

Wireless Power Transfer Technology Recommended by Toshiba



Qi (pronounced *chee*) is an international standard for inductive charging technology developed by the Wireless Power Consortium (WPC). Toshiba is a member of the WPC and is developing transmitter and receiver ICs to help promote wide market adoption of Qi for rechargeable mobile devices.

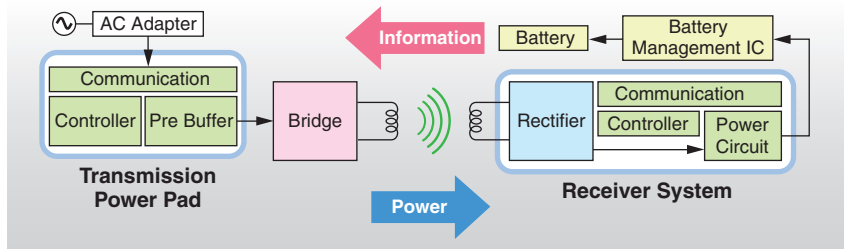

Transmitter for Qi wireless power transfer applications

TB6865AFG

The TB6865AFG is a transmitter IC for wireless power transfer. It integrates dedicated analog circuitry and an ARM® Cortex®-M3 processor in the same package, simplifying the development of a Qi-compliant power transmission pad ("Base Station"). Toshiba also offers a receiver IC for Qi wireless power transfer applications. These transmitter and receiver ICs combine to make it possible to transfer power from the power transmitter to the power receiver.

Features

- Compliant with the A11, A12 and A14 power transmitter designs defined in the WPC low-power standard, Version 1.1
- Analog power supply: 4.5 V to 15.0 V
- Simultaneous charging of up to two mobile devices
- Support for foreign object detection via Analog Ping
- 100-pin LQFP
- Qi-certified by means of an evaluation board

Application Examples

- WPC-compliant wireless power transmission pad for charging mobile devices
- Mobile device accessories rated at 5 W or lower

TB6865AFG Evaluation Module

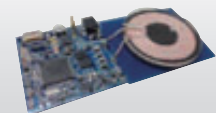

TB6865AFG EVM (A11)

Qi-Certified Wireless Power Receiver

TC7764WBG

The TC7764WBG is a receiver IC for Qi wireless power transfer applications. Fabricated using a CMOS/DMOS hybrid process, the TC7764WBG delivers high efficiency and low heat generation.

The TC7764WBG generates system control protocols stipulated in the Qi standard in hardware, eliminating the need for an external MCU. This makes it possible to create a receiver module with a single chip.

Features

- On-chip Qi protocol control logic
- Efficiency: 95% max.
- Low heat dissipation
- Compliant with Version 1.1 of the WPC low-power standard, which contains an enhancement for foreign object detection (FOD)
- 28-pin WCSP

Application Examples

- WPC-compliant smartphone accessories
- Mobile devices with a power consumption of 5 W or less



Recommended Parts

Functional Block	Product Category	Part Number	Features	WPC Standard Version	Output Voltage (V)	Output Current (W)	FOD	Package
Power Receiver	Wireless Power Transfer ICs	TB6860WBG	Receiver IC with a battery charging circuit; external MCU required; DC-DC converter output	v1.0	5	5		WCSP39
		TB6862WBG	Receiver IC; external MCU required; DC-DC converter output	v1.0	5	5		WCSP39
		TC7761WBG	Receiver IC with a controller; LDO output	v1.1	5	3.5	✓	WCSP28
		TC7763WBG	Receiver IC with a controller; LDO output	v1.1	5	5	✓	WCSP28
		TC7764WBG**	Receiver IC with a controller; LDO output; FOD offset adjustment via an external resistor	v1.1	5 to 5.3 *1	5.3	✓	WCSP28
		TC7765WBG**	Receiver IC with a controller; load switch output; FOD offset adjustment via an external resistor	v1.1	7 to 12 *2	10	✓	WCSP28
Power Transmitter	Wireless Power Transfer ICs	TB6865AFG	Transmitter control IC; simultaneous charging of up to two devices; support for A11, A12 and A14	v1.1		5 x 2	✓	LQFP100
Functional Block	Product Category	Part Number	Polarity	V _{DS} (V)	V _{GSS} (V)	I _D (A)	R _{DS(on)} Max (mΩ) @ V _{GS} = 14.5 V ¹	Package
Bridge	MOSFETs	SSM6K504NU	N-ch	30	±20	9	26	UDFN6B
		SSM6N55NU	N-ch x 2	30	±20	4	64	UDFN6
		SSM6P49NU	P-ch x 2	-20	±12	-4	56	UDFN6

*1 Selectable from four choices. A fixed output voltage is selectable through one-time programming (OTP).

*2 Selectable from four choices. A fixed output voltage is selectable from 7, 8, 9 and 12 V through one-time programming (OTP).

** Under development

Qi is a registered trademark of the Wireless Power Consortium.

*ARM and Cortex are registered trademarks of ARM Limited (or its subsidiaries) in the EU and/or countries elsewhere.

LCD TVs

Features

- The power supply module of LCD TVs consists of an AC-DC power supply, DC-DC converters, LDO regulators for peripheral ICs, and load switch ICs for power sequence control. LDO regulators provide a high-accuracy regulated voltage, and load switch ICs allow intricate power sequencing and offer thermal shutdown, overcurrent protection and other protection features.

Circuit Example

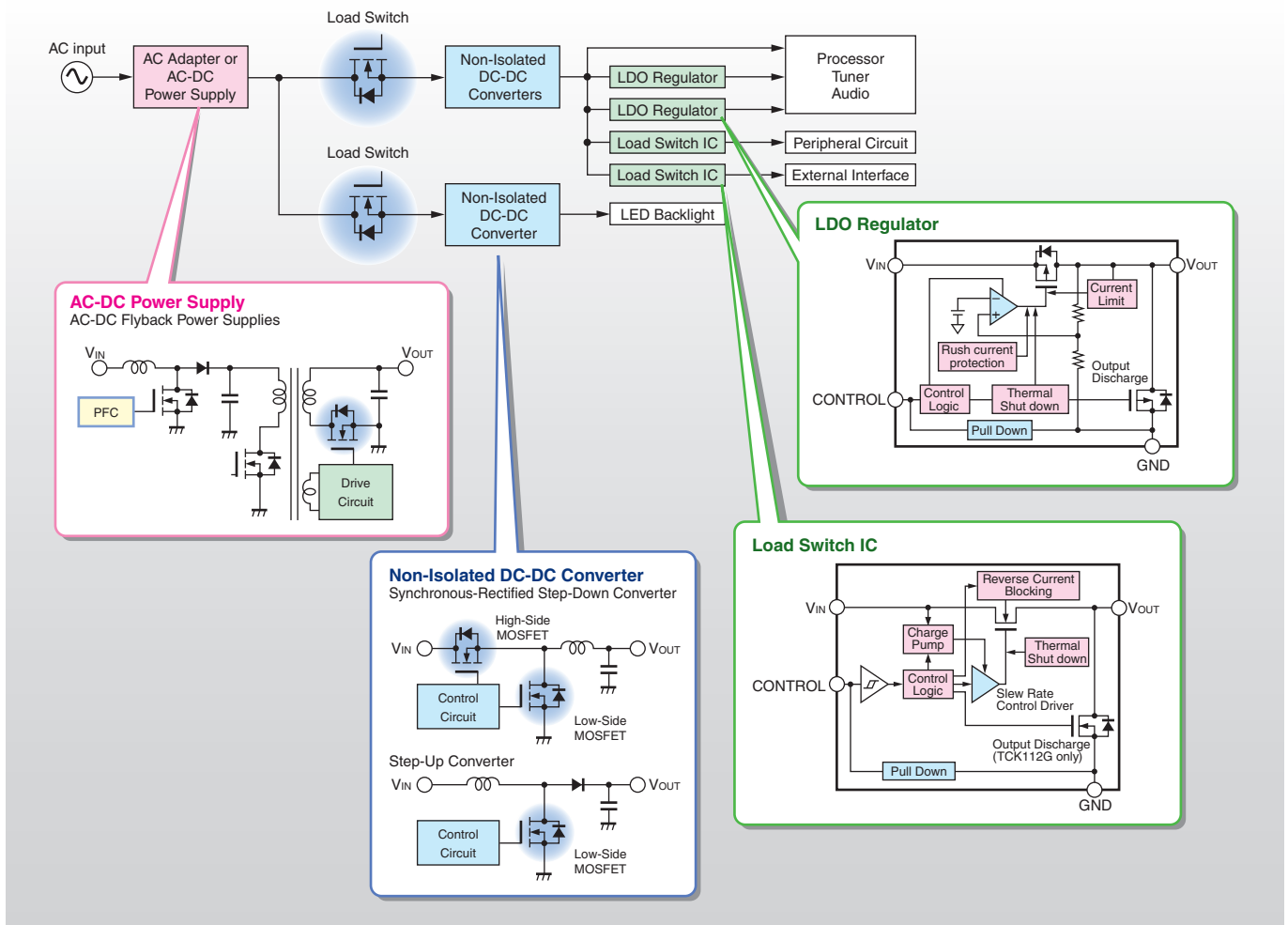

Recommended Parts

Functional Block	Product Category	Part Number
AC Adapter or AC-DC Power Supply	PFC Controller ICs	See the section "AC-DC Flyback Power Supplies" on page 4.
	High-Voltage Power MOSFETs	
	Synchronous Rectification MOSFET (Low-Voltage Power MOSFETs)	
Non-Isolated DC-DC Converter	High-Side MOSFET	See the section "Non-isolated DC-DC Converters" on page 8.
	Low-Side MOSFET	

Functional Block	Product Category	Part Number	Operating Voltage(V)	Output Current(A)	Features	Package
LDO Regulator	LDO Regulators	TCR5AM Series	0.55 to 3.6	0.5	Low-voltage power supply Low dropout voltage	DFN5B
		TCR3DF Series	1.0 to 4.5	0.3	Low noise Low dropout voltage	SMV
		TCR2EF Series, TCR2EE Series	1.0 to 5.0	0.2	Low noise	SMV, ESV
Load Switch IC	Load Switch ICs	TCK107G	1.1 to 5.5	1	Small form factor, low current consumption	WCSP4
		TCK105G	1.1 to 5.5	0.8	Overcurrent protection	WCSP6B
		TCK112G	1.1 to 5.5	3	Low on-resistance	WCSP6C
		TCK206G	0.75 to 3.6	2	Low-voltage drive	WCSP4C

Power Supplies by Application

Server Power Supplies

Features

- Since servers require a high-efficiency power supply, full-bridge AC-DC power supplies are most commonly used for server applications. Devices with fast switching and reverse recovery times help reduce switching and recovery losses and improve efficiency.

Circuit Example

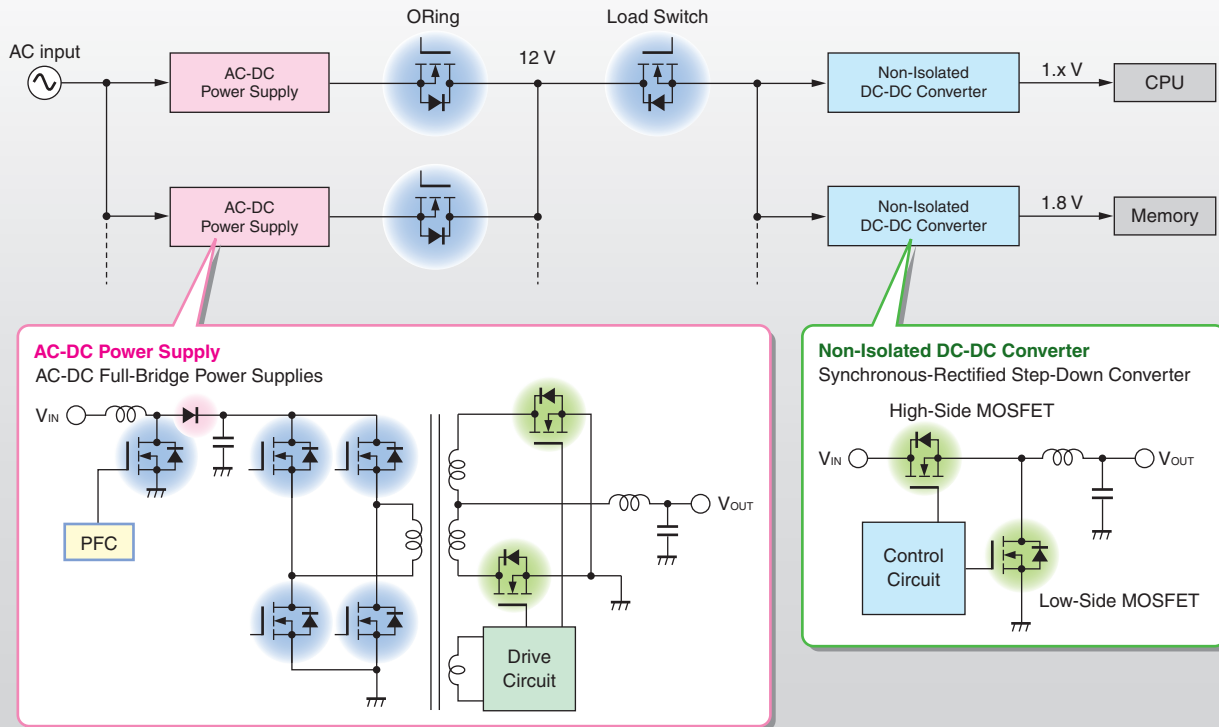

Recommended Parts

Functional Block	Product Category	Part Number
AC-DC Power Supply	PFC Controller ICs	See the section "AC-DC Resonant Half-Bridge Power Supplies" on page 7.
	High-Voltage Power MOSFETs	
	SiC Schottky Barrier Diode	
	Synchronous Rectification MOSFET (Low-Voltage Power MOSFETs)	
ORing	Reverse-Current Protection MOSFET	See the section "Non-isolated DC-DC Converters" on page 8.
Non-Isolated DC-DC Converter	High-Side MOSFET	
	Low-Side MOSFET	

► Solar Inverters (Power Conditioning Subsystems (PCS))

● Features

- A solar inverter, also known as a power conditioning subsystems (PCS), is a device used to convert DC power generated by solar panels to AC power for use by home appliances. Since the voltage from solar panels varies with sunshine conditions, it is boosted to a constant level first. It is then converted to AC power by using an inverter and then applied to the grid.

● Circuit Example

Capacity: 1 kW to 5 kW

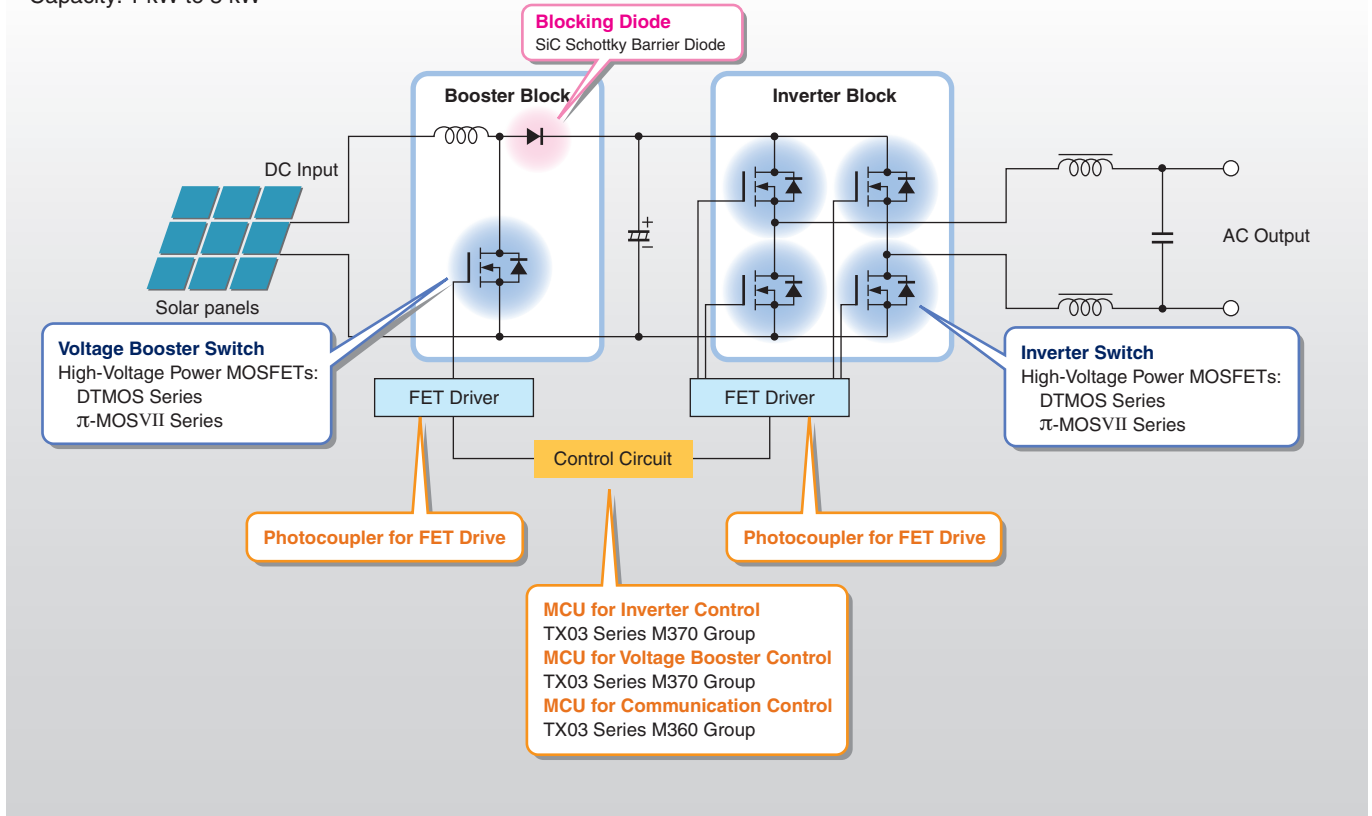

● Recommended Parts

Output Power (kW)			Up to 1.5	Up to 3	Up to 4.5	Up to 6
Inverter Switch	High-Voltage Power MOSFETs	Up to 500 Vdc input	TK39N60W5, TK62N60W5 TK35N65W5, TK49N65W5	TK62N60W5, TK100L60W TK49N65W5	TK100L60W	
	IGBTs	100-Vac Input / 200-Vac Input	GT30J341 GT50J342	GT30J341 GT50J342		
Control Circuit	MCU for Inverter Control		TMPM370FYDFG, TMPM370FYFG, TMPM372FWUG TMPM372FWFG**, TMPM373FWDUG, TMPM374FWUG TMPM375FSDMG, TMPM376FDDFG**, TMPM376FDFG			
	MCU for Voltage Booster Control					
	MCU for Communication Control		TMPM369FDFG, TMPM369FDXBG TMPM368FDFG, TMPM368FDXBG			
Voltage Booster Switch	High-Voltage Power MOSFETs	Up to 500-Vdc Output	TK39N60X TK62N60X	TK62N60X TK100L60W	TK100L60W	
	IGBTs	Up to 300-Vdc Output	GT50JR22	GT50JR22		
Blocking Diode	SiC Schottky Barrier Diode	Up to 300-Vdc Output / Up to 700-Vdc Output	TRS12N65D, TRS16N65D TRS20N65D, TRS24N65D	TRS20N65D, TRS24N65D		
MOSFET Gate Drive	Photocopplers	0.6 to 6.0-A Peak Output	TLP5214, TLP5751 TLP155E	TLP5214, TLP5751 TLP155E	TLP5214, TLP5754 TLP152	TLP358H, TLP5214 TLP5754

** Under development

▶ Power MOSFETs for PFC Control and Switching Applications

● **Gen-4 Super-Junction 600-V DTMOSIV MOSFET Series**
 Toshiba has developed the Gen-4 super-junction 600-V DTMOSIV MOSFET series. Fabricated using the state-of-the-art single epitaxial process, DTMOSIV provides a 30% reduction in RonA, a figure of merit (FOM) for MOSFETs, compared to its predecessor, DTMOSIII. A reduction in RonA makes it possible to house lower-Ron chips in the same packages. This helps to improve the efficiency and reduce the size of power supplies.

● **30% reduction in RonA, a MOSFET figure of merit, compared to the predecessor (DTMOSIII)**

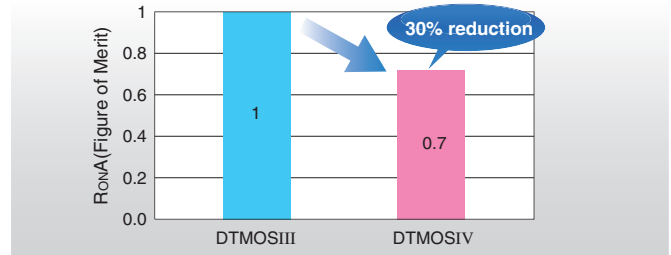

● DTMOSIV Lineup

<ul style="list-style-type: none"> ● V_{DSS} = 600 V DTMOSIV Series Improved performance because of reduced RonA Helps to improve the efficiency of various power supplies 	Standard DTMOSIV Series
	High-speed switching DTMOSIV-H Series Low switching loss because of fast switching performance Approx. 30% reduction in Qgd compared with the standard series
<ul style="list-style-type: none"> ● V_{DSS} = 650 V DTMOSIV Series Higher breakdown voltage thanks to an improvement of the 600-V version Easy to allow sufficient voltage tolerance margins for power supply designs 	DTMOSIV(HSD) Series with a high-speed diode MOSFET with faster parasitic diode Body diode with the reverse recovery time approx. 1/3 that of the standard series
	Standard DTMOSIV Series
	DTMOSIV(HSD) Series with a high-speed diode MOSFET with faster parasitic diode Body diode with the reverse recovery time approx. 1/3 that of the standard series

● DTMOSIV Part Naming Conventions

Part number example

T K 1 6 A 6 0 W 5
 ① ② ③ ④ ⑤ ⑥

- ① N-channel transistor
- ② Rated current (rounded off to integer)
- ③ Package
- ④ Rated voltage (V_{DSS} × 10%)
- ⑤ Process generation
W: DTMOSIV
X: High-speed switching DTMOSIV-H
- ⑥ Feature
5: Built-in high-speed diode

● Product Lineup

Series	Part Number	Absolute Maximum Ratings		R _{DS(ON)} Max (Ω) V _{GS} = 10 V	Package		
		V _{DSS} (V)	I _D (A)				
Standard DTMOSIV	TK5A60W	600	5.4	0.9	TO-220SIS		
	TK5P60W				DPAK		
	TK5Q60W				IPAK		
	TK7A60W				TO-220SIS		
	TK7P60W				DPAK		
	TK7Q60W		IPAK				
	TK10A60W		9.8	0.38	TO-220SIS		
	TK12A60W		11.5	0.3	TO-220SIS		
	TK12E60W				TO-220		
	TK12P60W				DPAK		
	TK12Q60W	IPAK					
	TK16A60W	15.8	0.19	TO-220SIS			
	TK16E60W			TO-220			
	TK16V60W			DFN8x8			
	TK20A60W	20	0.155	TO-220SIS			
	TK20E60W			TO-220			
	TK20N60W			TO-247			
	TK31A60W			30.8	0.088	TO-220SIS	
	TK31E60W	TO-220					
	TK31V60W	DFN8x8					
TK39A60W	38.8	0.065	TO-220SIS				
TK39N60W			TO-247				
TK62N60W	61.8	0.04	TO-247				
TK100L60W	100	0.018	TO-3P (L)				
Standard DTMOSIV	TK11A65W	650	11.1	0.39	TO-220SIS		
	TK14A65W				13.7	0.25	TO-220SIS
	TK14E65W						TO-220
	TK17A65W				17.3	0.2	TO-220SIS
	TK28N65W				27.6	0.11	TO-247
	TK35A65W		35	0.08	TO-220SIS		
	TK35N65W				TO-247		
	TK49N65W				49	0.055	TO-247

Series	Part Number	Absolute Maximum Ratings		R _{DS(ON)} Max (Ω) V _{GS} = 10 V	Package		
		V _{DSS} (V)	I _D (A)				
High-speed switching DTMOSIV-H	TK25A60X	600	25	0.125	TO-220SIS		
	TK25N60X				TO-247		
	TK31N60X				30.8	0.088	TO-247
	TK39N60X				38.8	0.065	TO-247
	TK62N60X				61.8	0.04	TO-247
	TK7A60W5				7	0.65	TO-220SIS
TK7P60W5	DPAK						
DTMOSIV (HSD)	TK8A60W5	8	0.54	0.56	TO-220SIS		
	TK8P60W5				DPAK		
	TK10A60W5				9.8	0.45	TO-220SIS
	TK16A60W5	15.8	0.23	TO-220SIS			
	TK16E60W5			TO-220			
	TK16N60W5			TO-247			
	TK20A60W5			20	0.175	TO-220SIS	
	TK20N60W5	20	0.099	0.074	TO-247		
	TK31N60W5				30.8		
	TK39N60W5				38.8		
	TK62N60W5				61.8		
	DTMOSIV (HSD)	TK14A65W5	650	13.7	0.3	TO-220SIS	
		TK14E65W5				TO-220	
		TK14N65W5				TO-247	
TK17A65W5		17.3				0.23	TO-220SIS
TK28N65W5		27.6	0.13	0.095	TO-247		
TK35A65W5					35		
TK35N65W5		49	0.057	0.057	TO-220SIS		
TK49N65W5					TO-247		

Detailed information about our MOSFETs is available on our website: <http://toshiba.semicon-storage.com/>

Synchronous Rectification MOSFETs

U-MOSVIII-H Series ($V_{DSS} = 60$ to 120 V)

Features

- 58% reduction in R_{onA} compared with U-MOSIV
- Improved efficiency at light loads because of reduced C_{iss}
- Higher power supply efficiency than other manufacturers' products
- Voltage spike and ringing suppression via a parasitic snubber

Application Circuit Example

120-W flyback AC-DC converter

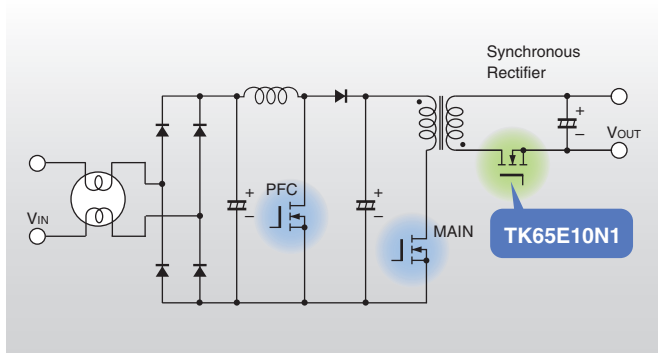

Roadmap for the U-MOS Series

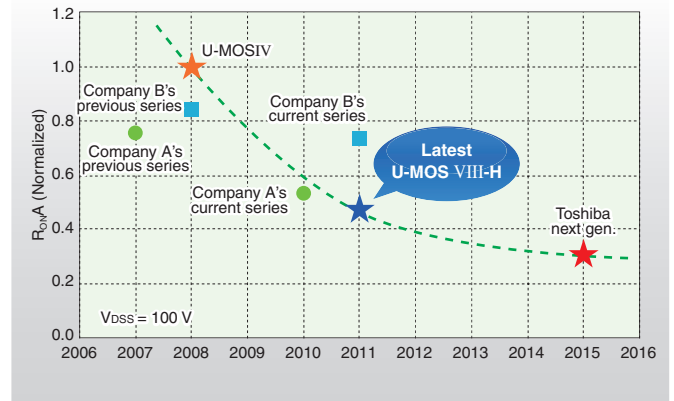

Product Lineup

Part Number	Package	Absolute Maximum Ratings				$R_{DS(on)}$ (m Ω) @ $V_{GS} = 10$ V		Qg (nC) Typ. $V_{DD} = V_{DSS} \times 0.8, I_D = I_{D(OC)}$	Q_{sw} (nC) Typ.
		V_{DSS} (V)	V_{GS} (V)	I_D (A)	P_D (W)	Typ.	Max		
TK100E06N1	TO-220*	60	± 20	263	255	1.9	2.3	140	56
TK58E06N1	TO-220*	60	± 20	105	110	4.4	5.4	46	17
TK40E06N1	TO-220*	60	± 20	60	67	8.4	10.4	23	10
TK30E06N1	TO-220*	60	± 20	43	53	12.2	15	16	6.8
TK100E08N1	TO-220*	80	± 20	214	255	2.6	3.2	130	53
TK72E08N1	TO-220*	80	± 20	157	192	3.6	4.3	81	33
TK46E08N1	TO-220*	80	± 20	80	103	6.9	8.4	37	16
TK35E08N1	TO-220*	80	± 20	55	72	10	12.2	25	10
TK100E10N1	TO-220*	100	± 20	207	255	2.8	3.4	140	55
TK65E10N1	TO-220*	100	± 20	148	192	4.0	4.8	81	32
TK40E10N1	TO-220*	100	± 20	90	126	6.8	8.2	49	21
TK34E10N1	TO-220*	100	± 20	75	103	7.9	9.5	38	15
TK22E10N1	TO-220*	100	± 20	52	72	11.5	13.8	28	12
TK72E12N1	TO-220*	120	± 20	179	255	3.6	4.4	130	52
TK56E12N1	TO-220*	120	± 20	112	168	5.8	7	69	29
TK42E12N1	TO-220*	120	± 20	88	140	7.8	9.4	52	23
TK32E12N1	TO-220*	120	± 20	60	98	11	13.8	34	15
TK65G10N1	D2PAK	100	± 20	136	156	3.8	4.5	81	32

* MOSFETs housed in the fully molded TO-220SIS package are also available.

Detailed information about our MOSFETs is available on our website: <http://toshiba.semicon-storage.com/>

Power MOSFETs

Low-Voltage MOSFETs for DC-DC Converter Applications ($V_{DSS} = 30$ to 250 V)

By employing microfabrication technology and reducing the gate charge, the power MOSFET series achieves extremely high speed and low $R_{DS(ON)}$.

Features

- Low $R_{DS(ON)}$
- High-speed switching
- Total gate charge (Qg) reduction
- High avalanche capability

Product Lineup

Configuration	Absolute Maximum Ratings			Part Number	Package	$R_{DS(ON)}$ Max (mΩ)		Qg (nC) Typ.
	V_{DSS} (V)	V_{GS} (V)	I_D (A)			$V_{GS} = 10$ V	$V_{GS} = 4.5$ V	
N-ch	30	±20	31	TPN11003NL	TSON Advance	11	16	3.3
			37	TPN8R903NL		8.9	12.7	4.4
			56	TPN6R003NL		6	8.3	8.2
			63	TPN4R303NL		4.3	6.3	6.8
			90	TPN2R703NL		2.7	4.1	9.5
			32	TPH11003NL		SOP Advance	11	16
			38	TPH8R903NL	8.9		12.7	4.4
			57	TPH6R003NL	6		8.3	8.2
			68	TPH4R003NL	4		6.2	6.8
			84	TPH3R203NL	3.2		4.7	9.5
			150	TPH1R403NL	1.4		2.1	20
			40	±20	220	TPHR9003NL	TSON Advance	0.9
	150	TPH1R204PL			0.85	1.4		103
	150	TPHR8504PL			1.24	2.1		74
	21	TPN22006NH			22	-		12
	33	TPN14006NH			14	-		15
	37	TPN11006NL			11.4	17		23
	60	±20	53	TPN7R506NH	SOP Advance	7.5	-	22
			34	TPH14006NH		14	-	16
			40	TPH11006NL		11.4	17	23
			55	TPH7R506NH		7.5	-	31
			71	TPH5R906NH		5.9	-	38
			85	TPH4R606NH		4.6	-	49
	80	±20	130	TPH2R306NH	TSON Advance	2.3	-	72
			22	TPN30008NH		30	-	11
			40	TPN13008NH		13.3	-	18
			44	TPH12008NH		12.3	-	22
			63	TPH8R008NH		8	-	35
			100	TPH4R008NH		4	-	59
	100	±20	21	TPN3300ANH	SOP Advance	33	-	11
			36	TPN1600ANH		16	-	19
			42	TPH1400ANH		13.6	-	22
			59	TPH8R80ANH		8.8	-	33
			93	TPH4R50ANH		4.5	-	58
			18	TPN5900CNH		59	-	7
	150	±20	18	TPH5900CNH	SOP Advance	59	-	7
			29	TPH3300CNH		33	-	10.6
			50	TPH1500CNH		15.4	-	22
			13	TPN1110ENH		114	-	7
	200	±20	13	TPH1110ENH	TSON Advance	114	-	7
			21	TPH6400ENH		64	-	11.2
			36	TPH2900ENH		29	-	22
9.9			TPN2010FNH	198		-	7	
250	±20	10	TPH2010FNH	SOP Advance	198	-	7	
		15	TPH1110FNH		112	-	11	
		27	TPH5200FNH		52	-	22	

* All the above MOSFETs are U-MOSVIII-H devices. Other devices of the U-MOSVIII-H Series and the U-MOSVI-H Series are also available.

Packaging trend for power devices

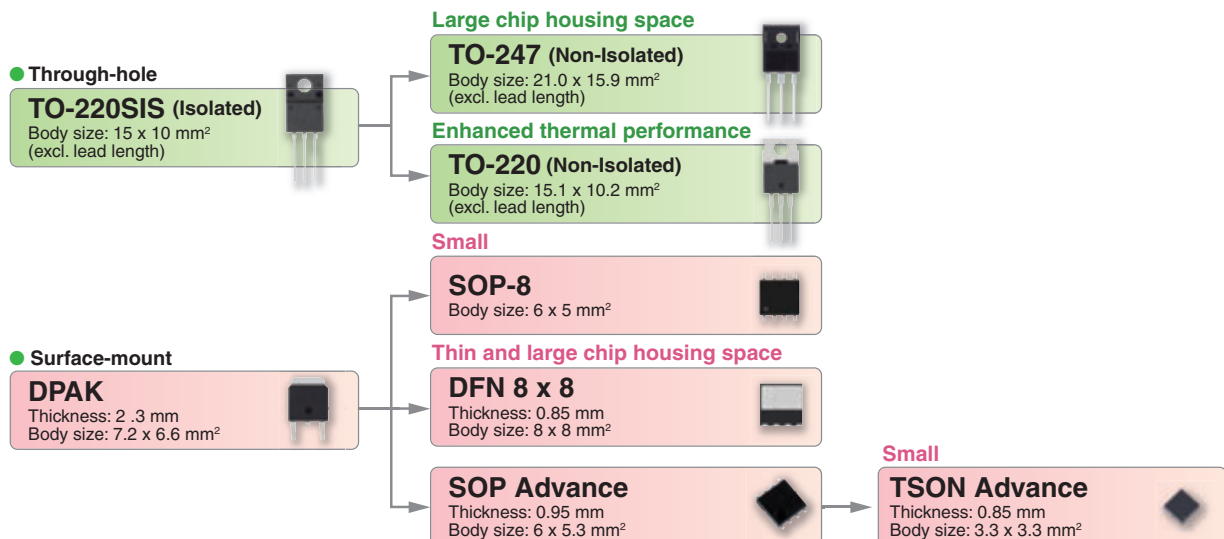

Detailed information about our MOSFETs is available on our website: <http://toshiba.semicon-storage.com/>

▶ Transistor-Output Photocouplers

TLP183/TLP293/TLP383

The TLP183 in the 4-pin SO6 package, the TLP293 in the SO4 package and the TLP383 in the 4-pin SO6L package are transistor-output photocouplers with low LED trigger current. These photocouplers guarantee the same current transfer ratio at the conventional LED trigger current (I_F) of 5 mA and at a paltry 0.5 mA, thanks to Toshiba's unique high-output LED. The maximum ambient temperature of 125°C makes them ideal for thermally demanding applications, including small power supplies and industrial equipment.

● Other Features

- Thin 4-pin SO6, SO4 and 4-pin SO6L packages with a thickness of 2.3 mm
- Manufactured at a fab in Thailand

● Product Lineup

(Photocouplers with transistor output providing isolated feedback from the secondary side to the primary side)

Package	Part Number	Absolute Maximum Ratings (Ta = 25°C)		Electrical Characteristics		Safety Standards		
		V _{CEO} (V)	Isolation voltage BVs (Vrms)	Current Transfer Ratio Ic/I _F (%)	Operating Ambient Temp. Topr (°C)	UL/c-UL	VDE EN60747-5-5	CQC GB4943, GB8898
SO6 (4pin)	TLP183	80	3750	50 to 600	-55 to 125	✓	✓	✓
SO4	TLP293	80	3750	50 to 600	-55 to 125	✓	✓	✓
SO6L (4pin)	TLP383	80	5000	50 to 600	-55 to 125	✓	✓	✓
	TLP385	80	5000	50 to 600	-55 to 110	✓	✓	✓

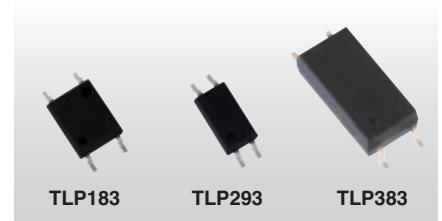

● Pin Configuration

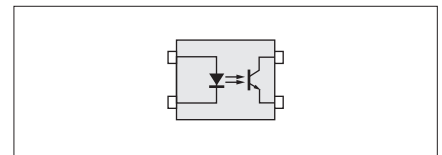

Packaging trend for photocouplers

To address the needs for power supply units requiring small, thin form factor, Toshiba is developing small, thin photocoupler packages.

● Packages with clearance and creepage distances of 8 mm (for IC-output photocouplers)

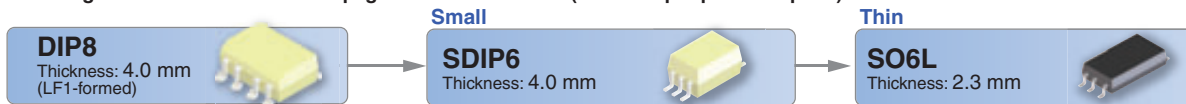

● Small packages (for transistor- and IC-output photocouplers)

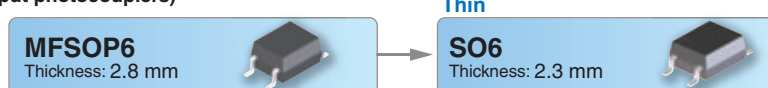

▶ Schottky Barrier Diodes (SBDs) for Power Factor Correction (PFC) Applications

● 650-V SiC Schottky Barrier Diodes

Silicon carbide (SiC), a wide-gap semiconductor, is expected to be a material for the next-generation high-voltage, low-loss power devices because its dielectric breakdown strength is more than eight times that of silicon (Si). Toshiba now offers the SiC Schottky barrier diodes listed below.

The following features of SiC Schottky barrier diodes make them ideal for power supply and inverter applications requiring high efficiency, such as those for servers, storage systems and photovoltaic power generators.

● Features



- Majority carrier device with a Schottky barrier structure
- High-speed switching
- Temperature-independent reverse recovery time (trr)
- Low V_F temperature coefficient
- Excellent trade-off between leakage current (I_R) and forward voltage (V_F) at high temperatures

● Physical property comparisons between Si and SiC

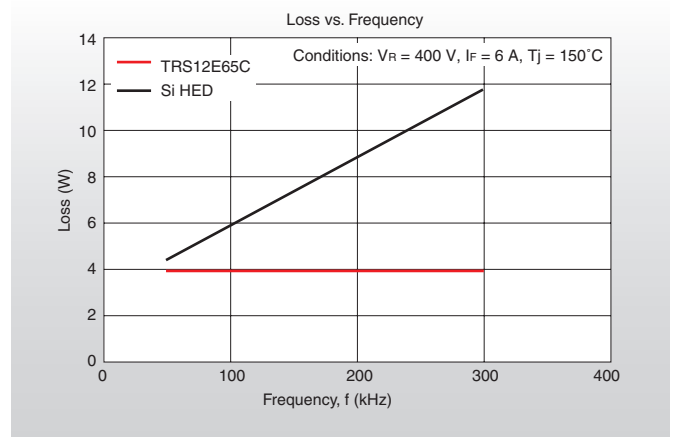
Item	Symbol	Si	SiC(4H)
Band gap	E	1.12eV	3.26eV
Electron mobility	μ	1400 cm ² /Vs	1000 cm ² /Vs
Relative dielectric constant	ϵ	11.8	9.7
Critical breakdown field	Ecr	0.3 MV/cm	2.5 MV/cm
Features		Easily available Easy to process Inexpensive	Suitable for reducing on-resistance Easy to guarantee high-temperature operations because of low leakage at high temperatures Easy to create designs with high withstand voltage
Transistor performance limit (at 600 V)	RonA	70 m Ω -cm ²	0.14 m Ω -cm ²





● Product Lineup

Package	Part Number	Absolute Maximum Ratings		Electrical Characteristics	
		Repetitive Peak Reverse Voltage V_{RRM} (V)	Forward DC Current $I_{F(DC)}$ (A)	Peak Forward Voltage V_{FM} (V) Typ./Max	Repetitive Peak Reverse Current I_{RRM} (μ A) Typ./Max
 TO-220-2L	TRS6E65C	650	6	1.5/1.7	0.3/90
	TRS8E65C	650	8	1.5/1.7	0.4/90
	TRS10E65C	650	10	1.5/1.7	0.42/90
	TRS12E65C	650	12	1.54/1.7	0.43/90
 TO-220F-2L	TRS6A65C	650	6	1.5/1.7	0.3/90
	TRS8A65C	650	8	1.5/1.7	0.4/90
	TRS10A65C	650	10	1.5/1.7	0.42/90
	TRS12A65C	650	12	1.54/1.7	0.43/90
 TO-247	TRS12N65D	650	12	1.5/1.7	0.3/90
	TRS16N65D	650	16	1.5/1.7	0.4/90
	TRS20N65D	650	20	1.5/1.7	0.42/90
	TRS24N65D	650	24	1.54/1.7	0.43/90

▶ Schottky Barrier Diodes (SBDs) and High-Efficiency Diodes (HEDs)



● Product Lineup

Schottky Barrier Diodes (SBDs)

Package	Part Number	Absolute Maximum Ratings					Electrical Characteristics (Max)					Conditions	
		V _{RRM} (V)	I _{F(AV)} (A)	I _{FSM} (A)	T _J (°C)	T _{stg} (°C)	I _{RRM} (mA)	V _{FM} (V)	@ I _{FM} (A)	C _i (pF)(Typ.)			
 US-FLAT™	CUS05	20	1.0	20	125	-40 to 150	1.0	0.37	0.7	40	V _R = 10 V, f = 1 MHz		
	CUS06			20	150	-40 to 150	0.03	0.45	0.7	40			
	CUS01	30		20	125	-40 to 150	1.5	0.37	0.7	40			
	CUS02			20	150	-40 to 150	0.1	0.45	0.7	40			
	CUS10I30A			20	150	-55 to 150	0.06	0.39	0.7	50			
	CUS15I30A			1.5	20	150	-55 to 150	0.06	0.46	1.5		50	
	CUS03	40	0.7	20	150	-40 to 150	0.1	0.52	0.7	45			
	CUS10I40A		1.0	20	150	-55 to 150	0.06	0.49	0.7	35			
	CUS04	60	0.7	20	150	-40 to 150	0.1	0.58	0.7	38			
	 S-FLAT™	CRS06	20	1.0	20	125	-40 to 150	1	0.36	1.0		60	V _R = 10 V, f = 1 MHz
CRS01		20			125	-40 to 150	1.5	0.37	0.7	40			
CRS03		30	20		150	-40 to 150	0.1	0.45	0.7	40			
CRS05			20		150	-40 to 150	▽	0.45	1.0	60			
CRS11			20		125	-40 to 150	1.5	0.36	1.0	60			
CRS10I30A			20		150	-55 to 150	0.06	0.39	0.7	50			
CRS10I30B			20		150	-55 to 150	0.06	0.42	1.0	50			
CRS10I30C			30		150	-55 to 150	0.10	0.36	1.0	82			
CRS08		30	1.5		30	125	-40 to 150	1	0.36	1.5	90		
CRS09			30		150	-40 to 150	0.05	0.46	1.5	90			
CRS15I30A			20		150	-55 to 150	0.06	0.46	1.5	50			
CRS15I30B			30		150	-55 to 150	0.10	0.40	1.5	82			
CRS14		30	2.0		30	150	-40 to 150	0.05	0.49	2.0	90		
CRS20I30A			20		150	-55 to 150	0.06	0.49	2.0	50			
CRS20I30B		30	150	-55 to 150	0.10	0.45	2.0	82					
CRS15 ◇		30	3.0	30	150	-40 to 150	0.05	0.52	3.0	90			
CRS30I30A			30	150	-55 to 150	0.10	0.49	3.0	82				
CRS04		40	1.0	20	150	-40 to 150	0.1	0.49	0.7	47			
CRS10I40A				20	150	-55 to 150	0.06	0.49	0.7	35			
CRS10I40B			25	150	-55 to 150	0.10	0.45	1.0	62				
CRS15I40A			1.5	20	150	-55 to 150	0.06	0.55	1.5	35			
CRS20I40A			20	150	-55 to 150	0.06	0.60	2.0	35				
CRS20I40B			25	150	-55 to 150	0.10	0.52	2.0	62				
CRS12		60	1.0	20	150	-40 to 150	0.1	0.58	1.0	40			
CRS13				20	150	-40 to 150	0.05	0.55	1.0	40			
 M-FLAT™		CMS08	30	1.0	25	125	-40 to 150	1.5	0.37	1.0	70	V _R = 10 V, f = 1 MHz	
		CMS09			25	150	-40 to 150	0.5	0.45	1.0	70		
		CMS10I30A			30	150	-55 to 150	0.10	0.36	1.0	82		
	CMS06	2.0		40	125	-40 to 150	3.0	0.37	2.0	130			
	CMS07			40	150	-40 to 150	0.5	0.45	2.0	130			
	CMS17			30	150	-40 to 150	0.1	0.48	2.0	90			
	CMS20I30A	3.0	30	150	-55 to 150	0.10	0.45	2.0	82				
	CMS01		40	125	-40 to 150	5.0	0.37	3.0	190				
	CMS03		40	150	-40 to 150	0.5	0.45	3.0	190				
	CMS30I30A	5.0	30	150	-55 to 150	0.10	0.49	3.0	82				
	CMS04		70	125	-40 to 150	8.0	0.37	5.0	330				
	CMS05	70	150	-40 to 150	0.8	0.45	5.0	330					
	CMS10	40	1.0	25	150	-40 to 150	0.5	0.55	1.0	50			
	CMS10I40A			25	150	-55 to 150	0.10	0.45	1.0	62			
	CMS15I40A		1.5	25	150	-55 to 150	0.10	0.49	1.5	62			
	CMS11		2.0	30	150	-40 to 150	0.5	0.55	2.0	95			
	CMS20I40A		25	150	-55 to 150	0.10	0.52	2.0	62				
	CMS16		30	150	-40 to 150	0.2	0.55	3.0	95				
	CMS30I40A	60	2.0	25	150	-55 to 150	0.10	0.55	3.0	62			
	CMS14			40	150	-40 to 150	0.2	0.58	2.0	77			
	CMS15			3.0	60	150	-40 to 150	0.3	0.58	3.0	102		

▽: I_{RRM} = 5 μA Max (V_R = 5 V) ◇: I_{F(DC)} = 3 A

High-Efficiency Diodes (HEDs)

Package	Part Number	Absolute Maximum Ratings					Electrical Characteristics (Max)					Conditions
		V _{RRM} (V)	I _{F(AV)} (A)	I _{FSM} (A)	T _J (°C)	T _{stg} (°C)	I _{RRM} (μA)	V _{FM} (V)	@ I _{FM} (A)	t _{rr} (ns)		
 S-FLAT™	CRH02	200	0.5	10	150	-40 to 150	10	0.95	0.5	35	I _F = 1 A, di/dt = -30 A/μs	
	CRH01		1.0	15	150	-40 to 150	10	0.98	1.0	35		
 M-FLAT™	CMH04		1.0	20	150	-40 to 150	10	0.98	1.0	35		
	CMH07		2.0	40	150	-40 to 150	10	0.98	2.0	35		
	CMH01		3.0	30	150	-40 to 150	0.2	0.55	3.0	95		
				25	150	-55 to 150	0.10	0.52	2.0	62		

Bipolar Power Transistors

Switching Power Transistors

Product Lineup

Package	Part Number	Absolute Maximum Ratings (Ta = 25°C)				hFE				VCE (sat) Max			Switching Characteristics (μs)		
		V _{CEO} (V)	V _{CE0} (V)	I _C (A)	P _C (W)	Min	Max	V _{CE} (V)	I _C (A)	(V)	I _C (A)	I _B (A)	t _r	t _{stg}	t _f
PW-Mini	TTC005	600	285	1	1.1 *1	100	200	5	0.1	1	0.6	75 m	0.2	2	0.13
	TTC013	600	350	0.5	1.0 *1	100	200	5	0.05	0.3	0.16	20 m	0.12	3.2	0.17
New PW-Mold	2SC5548A	600	400	2	15 *2	40	100	5	0.2	1	0.8	0.1	0.5 (Max)	3.0 (Max)	0.3 (Max)
	TTC014	900	800	1	40 *2	100	200	5	0.1	1	0.5	50 m	0.2	4	0.4
New PW-Mold2	TTC008	600	285	1.5	1.1	100	200	5	0.3	1	0.5	62.5 m	0.05	3.3	0.1
	2SC6142	800	375	1.5	1.1	100	200	5	0.1	0.9	0.8	0.1	0.2	3.5	0.15
	TTC012	800	375	2	1.1	100	200	5	0.3	0.5	0.5	62.5 m	0.1	4.4	0.15
TO-3P (N)	2SC5354	900	800	5	100 *2	15	60	5	0.5	1	2	0.4	0.7 (Max)	4.0 (Max)	0.5 (Max)

*1: Mounted on FR4 board (Cu area: 645 mm²; glass epoxy; t = 1.6 mm) *2: Tc = 25°C

Power Transistors for MOS Gate Drivers (for High-Speed Gate Drive of MOS Devices)

MOS gate drivers incorporate a pair of low-V_{CE(sat)} PNP and NPN transistors in one package.

They are ideal for high-speed gate drive applications for high-power IGBTs and MOSFETs as well as for small-motor driver applications.

Application Example

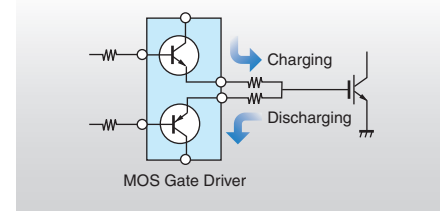

Product Lineup (2-in-1 Series)

Package	Part Number	Polarity	Absolute Maximum Ratings (Ta = 25°C)				hFE				VCE (sat) Max		
			V _{CEO} (V)	I _C (A)	I _{CP} (A)	P _C *1 (mW)	Min	Max	V _{CE} (V)	I _C (A)	(V)	I _C (A)	I _B (mA)
SMV	HN4B101J	PNP	-30	-1.0	-5	550	200	500	-2	-0.12	-0.2	-0.4	-13
		NPN	30	1.2	5	550	200	500	2	0.12	0.17	0.4	13
	HN4B102J	PNP	-30	-1.8	-8	750	200	500	-2	-0.2	-0.2	-0.6	-20
		NPN	30	2	8	750	200	500	2	0.2	0.14	0.6	20
VS-6	TPC6901A	PNP	-50	-0.7	-5	400	200	500	-2	-0.1	-0.23	-0.3	-10
		NPN	50	1	5	400	400	1000	2	0.1	0.17	0.3	6
	TPC6902	PNP	-30	-1.7	-8	700	200	500	-2	-0.2	-0.2	-0.6	-20
		NPN	30	2	8	700	200	500	2	0.2	0.14	0.6	20
PS-8	TPCP8901	PNP	-50	-0.8	-5	830	200	500	-2	-0.1	-0.2	-0.3	-10
		NPN	50	1	5	830	400	1000	2	0.1	0.17	0.3	6
	TPCP8902	PNP	-30	-2	-8	890	200	500	-2	-0.2	-0.2	-0.6	-20
		NPN	30	2	8	890	200	500	2	0.2	0.14	0.6	20

*1: The rating applies when the transistor is mounted on an FR-4 board (Cu area = 645 mm², glass-epoxy, t = 1.6 mm) and is in single-device operation. Copper thickness: 35 mm for the TPC6901A and 70 mm for the other transistors.

Bipolar Power Transistors for self-Excited DC-DC Converter Applications

The bipolar power transistors listed below are recommended for use as a primary-side switch in high-voltage power supplies.

Their input voltage can be as high as 24 V (V_{CEO} = 80 V or higher). The DC current gain, hFE, is guaranteed in the low-current region.

Example: 2SC6061

hFE: 100 or greater (@ V_{CE} = 2 V / I_C = 1 mA)

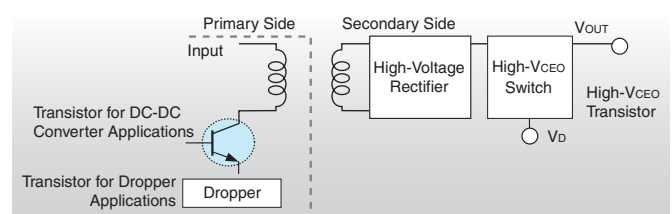

Product Lineup

Package	Part Number	Absolute Maximum Ratings (Ta = 25°C)				hFE				VCE (sat) Max		
		V _{CEX} (V)	V _{CE0} (V)	I _C (A)	P _C (W)	Min	Max	V _{CE} (V)	I _C (A)	(V)	I _C (A)	I _B (mA)
TSM	2SC6061	150	120	1	0.625 *1	120	300	2	0.1	0.14	0.3	10
PS-8	TPCP8510	150	120	1	1.1 *1	120	300	2	0.1	0.14	0.3	10
	TPCP8507	150	120	1	1.25 *1	120	300	2	0.1	0.14	0.3	10
New PW-Mold	2SC6076	160	80	3	10 *2	180	450	2	0.5	0.5	1	100
PW-Mini	2SC6124	160	80	2	1 *1	100	200	2	0.5	0.5	1	100
TO-126N	TTC015B	160	80	2	10 *2	100	200	2	0.5	0.5	1	100

*1: Mounted on FR4 board (Cu area: 645 mm²; glass epoxy; t = 1.6 mm) *2: Tc = 25°C

DC-DC Converter ICs

PFC Control ICs

Toshiba has been developing power factor correction (PFC) controllers for reducing power factor degradation (or an increase in reactive power) and noise on AC mains due to harmonics current.

TB6818FG

Features

- Operating voltage range: 8.4 V (min) to 26 V (max)
- Startup voltage: 10.0 V (typ.)
- Pulse output mute function (starting)
- Avoiding PFC transformer noise
- Maximum drive current: 1.0 A (typ.)
- Consumption current: 250 μ A (typ.)(Standby mode)
- AC instantaneously-stop detection
- Built-in protection circuits
 - DC input overvoltage protection (OVP-1)
 - PFC output overvoltage protection (OVP-2)
 - Undervoltage lockout (UVLO)
 - Feedback-loop open detection (FOD)
 - Thermal shutdown (TSD)

Block Diagram

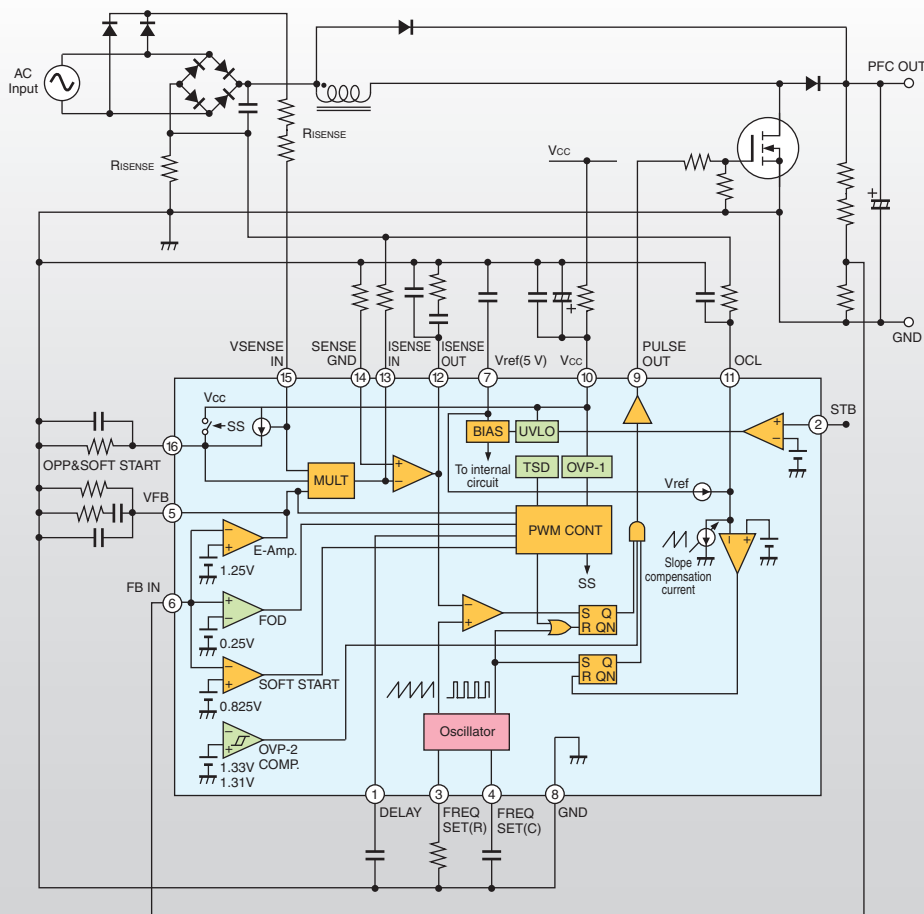

Product Lineup

Part Number	Conduction	Supply Voltage (V)	Package	Features
TB6818FG	CCM	8.4 to 26	SSOP16	Reduced humming noise emitted by the PFC transformer
TB6819AFG	CRM	9.5 to 25	SOP8	Brownout protection (BOP)

DC-DC Converter ICs

Multiple-Output DC-DC Converter ICs

Features

Multiple-output DC-DC converter ICs are power management ICs (PMICs) that integrate several DC-DC converters on a single chip for space-saving applications. One PMIC can supply power to multiple peripheral devices and meet the needs for various applications. Multiple-output DC-DC converters are available with various output channel options to meet diverse requirements.

Application Examples

- Smartphones
- Digital still cameras

Product Lineup

Part Number	Application	Power Configuration	Operating Input Voltage (V)	Switching Frequency (kHz)	Package
TC7731FTG	DDR2/3	Step-down converter: 1 ch (4 A), LDO: 1 ch (1.5 A)	2.7 to 5.5	500/1,000	QFN40
TC7732FTG	Smartphones	Step-down converter: 1 ch (1 A), LDO: 4 ch (0.3 A x 2, 0.15 A x 2)	2.7 to 5.5	4,000	QFN16
TC7734FTG **	Tablets	Step-down converter: 4 ch, LDO: 3 ch, LED drive: 2 ch, battery charger function (1.5 A)	3.4 to 5.5	1,000	QFN64
TC7735FTG	LCD panels	Step-up and step-down converters: 1 ch, Step-down converter: 1 ch, charge pump: 2 ch, Op-Amp: 1 ch	4.5 to 16	1,000	QFN32

** : Under development

Rechargeable Lithium-Ion Battery Charger

TC7710AWBG

Features

Many mobile devices have an embedded high-capacity lithium-ion battery pack in order to deliver extended playtime for wide-ranging applications such as music, video and games. Manufacturers of mobile devices have been striving to keep its charge time equal to or less than the predecessor. The TC7710AWBG provides the ideal solution for rechargeable lithium-ion battery chargers with a USB port. It is compliant with the Battery Charging Specification 1.2. Due to the adoption of a DC-DC converter, it offers high efficiency and a high charge current of 2 A.

Application Examples

- Devices with a rechargeable lithium-ion battery (e.g., smartphones, digital still cameras)

Five Benefits

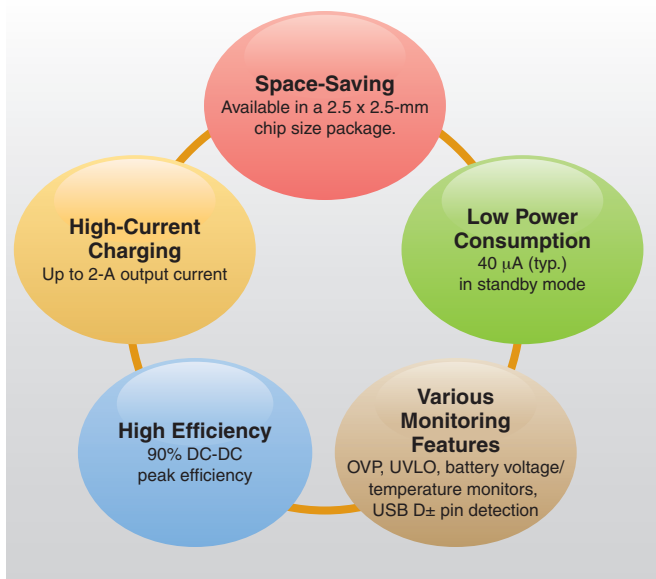

Application Circuit Example

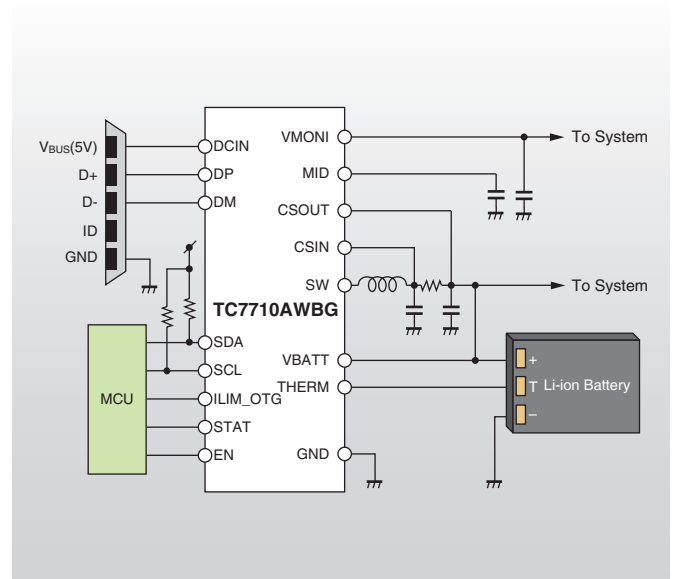

Product Lineup

Part Number	Operating Input Voltage (V)	Input Current (A)	Output Voltage (V)	Output Current (A)	Switching Frequency (kHz)	Package
TC7710AWBG	4.3 to 6.5	2 (max)	3.46 to 4.72	2 (max)	3000	WCSP25

Toshiba Semiconductor Web Simulator

MOSFETs
Load Switch ICs
Low-Drop Out Regulator ICs

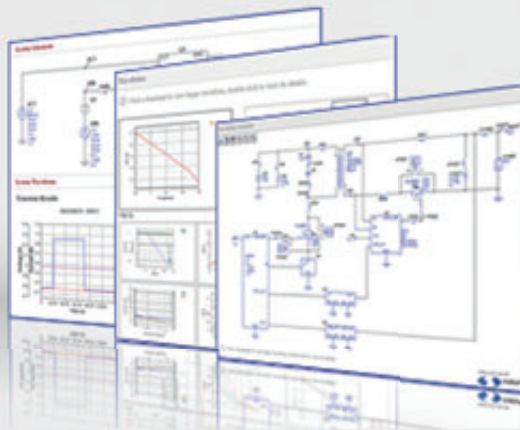

Toshiba offers an online tool that allows you to perform circuit simulation on MOSFETs, load switch ICs and LDO regulators.

- The Toshiba Semiconductor Web Simulator allows you to simulate the MOSFET performance under various voltage and temperature conditions.
- You can analyze the switching waveforms of MOSFETs in AC/DC and DC/DC converter applications.
- You can also simulate PFC, full-bridge, flyback and synchronous buck converters.
- In addition, you can simulate the behaviors of load switch ICs and LDO regulators.

* User registration is required to use the Web Simulator.

MOSFETs



Interactive Datasheet <Device characteristics simulation>

Allows you to check the performance characteristics curves shown in datasheets under arbitrary conditions.

Simulatable characteristics

I_D - V_{DS} , I_D - V_{GS} , $R_{DS(ON)}$ - V_{GS} , $R_{DS(ON)}$ - I_D , $R_{DS(ON)}$ - T_a , I_{DR} - V_{DS} , C - V_{DS} , Q_g and other curves

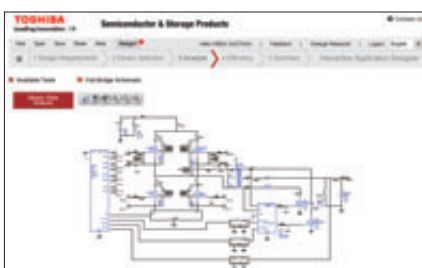

Interactive Application Designer <Circuit simulation>

Allows you analyze the switching waveforms and power efficiencies of AC-DC and DC-DC converters.

Supported power supply topologies

- Power factor correction (PFC) circuits
- Full-bridge converters
- Flyback converters
- Buck converters

Load Switch ICs/LDO Regulators

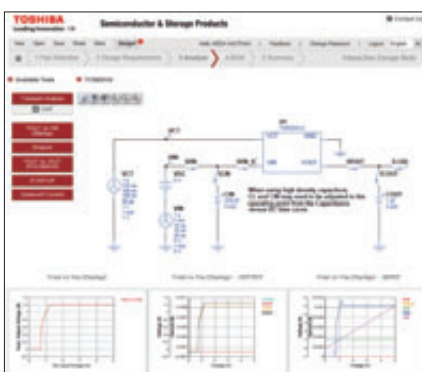

Interactive Design Note <Circuit simulation>

You can perform circuit simulation on load switch ICs and LDO regulators.

Supported simulation

- Transient analysis
- Startup analysis
- $R_{DS(ON)}$ - V_{IN} and $R_{DS(ON)}$ - I_{OUT} characteristics
- Inrush current

Toshiba America**Electronic Components, Inc.**

- Irvine, Headquarters
Tel: (949)462-7700 Fax: (949)462-2200
- Buffalo Grove (Chicago)
Tel: (847)484-2400 Fax: (847)541-7287
- Duluth/Atlanta
Tel: (770)931-3363 Fax: (770)931-7602
- El Paso
Tel: (915)533-4242
- Marlborough
Tel: (508)481-0034 Fax: (508)481-8828
- Parsippany
Tel: (973)541-4715 Fax: (973)541-4716
- San Jose
Tel: (408)526-2400 Fax: (408)526-2410
- Wixom (Detroit)
Tel: (248)347-2607 Fax: (248)347-2602

TOSHIBA América do Sul Ltda.

Tel: (011)4083-7978

Toshiba India Private Ltd.

- New Delhi Office
Tel: (0124)499-6600 Fax: (0124)499-6611
- Bangalore Office
Tel: (080)251-90800 Fax: (080)490-91945

Toshiba Electronics Europe GmbH

- Düsseldorf Head Office
Tel: (0211)5296-0 Fax: (0211)5296-400
- France Branch
Tel: (1)47282181
- Italy Branch
Tel: (039)68701 Fax: (039)6870205
- Munich Office
Tel: (089)20302030 Fax: (089)203020310
- Spain Branch
Tel: (91)660-6798 Fax: (91)660-6799
- Sweden Branch
Tel: (08)704-0900 Fax: (08)80-8459
- U.K. Branch
Tel: (1932)841600

Toshiba Vietnam Consumer Products Co.,Ltd.

Tel: (043)776-5950 Fax: (043)776-5956

Toshiba Electronics Asia (Singapore) Pte. Ltd.

Tel: (6278)5252 Fax: (6271)5155

Toshiba Electronics Service (Thailand) Co., Ltd.

Tel: (02)835-3491 Fax: (02)835-3490

Toshiba Electronics Trading (Malaysia)Sdn. Bhd.

- Kuala Lumpur Head Office
Tel: (03)5631-6311 Fax: (03)5631-6307
- Penang Office
Tel: (04)226-8523 Fax: (04)226-8515

Toshiba Electronics (China) Co., Ltd.

- Shanghai Head Office
Tel: (021)6139-3888 Fax: (021)6190-8288
- Beijing Branch
Tel: (010)6590-8796 Fax: (010)6590-8791
- Chengdu Branch
Tel: (028)8675-1773 Fax: (028)8675-1065
- Hangzhou Office
Tel: (0571)8717-5004 Fax: (0571)8717-5013
- Nanjing Office
Tel: (025)8689-0070 Fax: (025)8689-0125
- Qingdao Branch
Tel: (532)8579-3328 Fax: (532)8579-3329
- Shenzhen Branch
Tel: (0755)3686-0880 Fax: (0755)3686-0816
- Dalian Branch
Tel: (0411)8368-6882 Fax: (0411)8369-0822
- Xiamen Branch
Tel: (0592)226-1398 Fax: (0592)226-1399
- Dongguan Branch
Tel: (0769)8155-6858 Fax: (0769)8155-6368
- Toshiba Electronics Asia, Ltd.
Tel: 2375-6111 Fax: 2375-0969
- Toshiba Electronics Korea Corporation
Tel: (02)3484-4334 Fax: (02)3484-4302
- Toshiba Electronic Components Taiwan Corporation
Tel: (02)2508-9988 Fax: (02)2508-9999

RESTRICTIONS ON PRODUCT USE

- ▶ Toshiba Corporation, and its subsidiaries and affiliates (collectively "TOSHIBA"), reserve the right to make changes to the information in this document, and related hardware, software and systems (collectively "Product") without notice.
- ▶ This document and any information herein may not be reproduced without prior written permission from TOSHIBA. Even with TOSHIBA's written permission, reproduction is permissible only if reproduction is without alteration/omission.
- ▶ Though TOSHIBA works continually to improve Product's quality and reliability, Product can malfunction or fail. Customers are responsible for complying with safety standards and for providing adequate designs and safeguards for their hardware, software and systems which minimize risk and avoid situations in which a malfunction or failure of Product could cause loss of human life, bodily injury or damage to property, including data loss or corruption. Before customers use the Product, create designs including the Product, or incorporate the Product into their own applications, customers must also refer to and comply with (a) the latest versions of all relevant TOSHIBA information, including without limitation, this document, the specifications, the data sheets and application notes for Product and the precautions and conditions set forth in the "TOSHIBA Semiconductor Reliability Handbook" and (b) the instructions for the application with which the Product will be used with or for. Customers are solely responsible for all aspects of their own product design or applications, including but not limited to (a) determining the appropriateness of the use of this Product in such design or applications; (b) evaluating and determining the applicability of any information contained in this document, or in charts, diagrams, programs, algorithms, sample application circuits, or any other referenced documents; and (c) validating all operating parameters for such designs and applications. **TOSHIBA ASSUMES NO LIABILITY FOR CUSTOMERS' PRODUCT DESIGN OR APPLICATIONS.**
- ▶ **PRODUCT IS NEITHER INTENDED NOR WARRANTED FOR USE IN EQUIPMENTS OR SYSTEMS THAT REQUIRE EXTRAORDINARILY HIGH LEVELS OF QUALITY AND/OR RELIABILITY, AND/OR A MALFUNCTION OR FAILURE OF WHICH MAY CAUSE LOSS OF HUMAN LIFE, BODILY INJURY, SERIOUS PROPERTY DAMAGE AND/OR SERIOUS PUBLIC IMPACT ("UNINTENDED USE").** Except for specific applications as expressly stated in this document, Unintended Use includes, without limitation, equipment used in nuclear facilities, equipment used in the aerospace industry, medical equipment, equipment used for automobiles, trains, ships and other transportation, traffic signaling equipment, equipment used to control combustions or explosions, safety devices, elevators and escalators, devices related to electric power, and equipment used in finance-related fields. **IF YOU USE PRODUCT FOR UNINTENDED USE, TOSHIBA ASSUMES NO LIABILITY FOR PRODUCT.** For details, please contact your TOSHIBA sales representative.
- ▶ Do not disassemble, analyze, reverse-engineer, alter, modify, translate or copy Product, whether in whole or in part.
- ▶ Product shall not be used for or incorporated into any products or systems whose manufacture, use, or sale is prohibited under any applicable laws or regulations.
- ▶ The information contained herein is presented only as guidance for Product use. No responsibility is assumed by TOSHIBA for any infringement of patents or any other intellectual property rights of third parties that may result from the use of Product. No license to any intellectual property right is granted by this document, whether express or implied, by estoppel or otherwise.
- ▶ **ABSENT A WRITTEN SIGNED AGREEMENT, EXCEPT AS PROVIDED IN THE RELEVANT TERMS AND CONDITIONS OF SALE FOR PRODUCT, AND TO THE MAXIMUM EXTENT ALLOWABLE BY LAW, TOSHIBA (1) ASSUMES NO LIABILITY WHATSOEVER, INCLUDING WITHOUT LIMITATION, INDIRECT, CONSEQUENTIAL, SPECIAL, OR INCIDENTAL DAMAGES OR LOSS, INCLUDING WITHOUT LIMITATION, LOSS OF PROFITS, LOSS OF OPPORTUNITIES, BUSINESS INTERRUPTION AND LOSS OF DATA, AND (2) DISCLAIMS ANY AND ALL EXPRESS OR IMPLIED WARRANTIES AND CONDITIONS RELATED TO SALE, USE OF PRODUCT, OR INFORMATION, INCLUDING WARRANTIES OR CONDITIONS OF MERCHANTABILITY, FITNESS FOR A PARTICULAR PURPOSE, ACCURACY OF INFORMATION, OR NON-INFRINGEMENT.**
- ▶ Product may include products using GaAs (Gallium Arsenide). GaAs is harmful to humans if consumed or absorbed, whether in the form of dust or vapor. Handle with care and do not break, cut, crush, grind, dissolve chemically or otherwise expose GaAs in Product.
- ▶ Do not use or otherwise make available Product or related software or technology for any military purposes, including without limitation, for the design, development, use, stockpiling or manufacturing of nuclear, chemical, or biological weapons or missile technology products (mass destruction weapons). Product and related software and technology may be controlled under the applicable export laws and regulations including, without limitation, the Japanese Foreign Exchange and Foreign Trade Law and the U.S. Export Administration Regulations. Export and re-export of Product or related software or technology are strictly prohibited except in compliance with all applicable export laws and regulations.
- ▶ Please contact your TOSHIBA sales representative for details as to environmental matters such as the RoHS compatibility of Product. Please use Product in compliance with all applicable laws and regulations that regulate the inclusion or use of controlled substances, including without limitation, the EU RoHS Directive. **TOSHIBA ASSUMES NO LIABILITY FOR DAMAGES OR LOSSES OCCURRING AS A RESULT OF NONCOMPLIANCE WITH APPLICABLE LAWS AND REGULATIONS.**



TOSHIBA**TOSHIBA CORPORATION**

Semiconductor & Storage Products Company

Website: <http://toshiba.semicon-storage.com/>

Looking for pricing, stock, or lifecycle information?

Click below to explore more details on WIN SOURCE:

-  [View TCR2EF18,LM\(CT on WIN SOURCE](#)
-  [Toshiba Semiconductor and Storage Information](#)

Optimize Your Supply Chain with WIN SOURCE Solutions

-  Global Sourcing Solution
-  Obsolete Management
-  Cost Control Management
-  Shortage Management
-  Alternative Solution
-  Excess Inventory Management