

PACKAGE DIMENSIONS inch (mm)

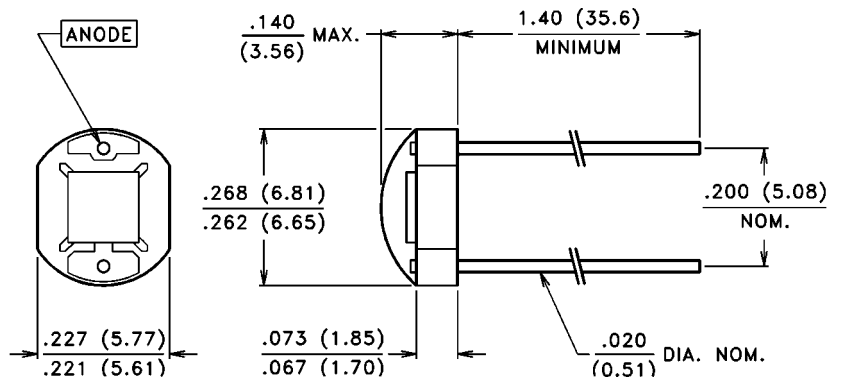

CASE 11 CERAMIC
CHIP ACTIVE AREA: .012 in² (7.45 mm²)

PRODUCT DESCRIPTION

Planar silicon photodiode mounted on a two lead ceramic substrate and coated with a thick layer of clear epoxy. These diodes exhibit low dark current under reverse bias and fast speed of response.

ABSOLUTE MAXIMUM RATINGS

Storage Temperature: -20°C to 75°C
Operating Temperature: -20°C to 75°C

ELECTRO-OPTICAL CHARACTERISTICS @ 25°C (See also VTP curves, pages 45-46)

SYMBOL	CHARACTERISTIC	TEST CONDITIONS	VTP8350H			UNITS
			Min.	Typ.	Max.	
I _{SC}	Short Circuit Current	H = 100 fc, 2850 K	65	80		μA
TC I _{SC}	I _{SC} Temperature Coefficient	2850 K		.20		%/°C
V _{OC}	Open Circuit Voltage	H = 100 fc, 2850 K		350		mV
TC V _{OC}	V _{OC} Temperature Coefficient	2850 K		-2.0		mV/°C
I _D	Dark Current	H = 0, V _R = 10 V			30	nA
R _{SH}	Shunt Resistance	H = 0, V = 10 mV		100		GΩ
C _J	Junction Capacitance	H = 0, V = 3 V			50	pF
Re	Responsivity	940 nm		.06		A/(W/cm ²)
S _R	Sensitivity	@ Peak		.55		A/W
λ _{range}	Spectral Application Range		400		1150	nm
λ _p	Spectral Response - Peak			925		nm
V _{BR}	Breakdown Voltage		33	140		V
θ _{1/2}	Angular Resp. - 50% Resp. Pt.			±60		Degrees
NEP	Noise Equivalent Power			1.8 x 10 ⁻¹³ (Typ.)		W/√Hz
D*	Specific Detectivity			1.5 x 10 ¹² (Typ.)		cm√Hz/W

Looking for pricing, stock, or lifecycle information?

Click below to explore more details on WIN SOURCE:

- ⊖ [View VTP8350H on WIN SOURCE](#)
- ⊖ [Excelitas Technologies Information](#)

Optimize Your Supply Chain with WIN SOURCE Solutions

- ✓ Global Sourcing Solution
- ✓ Obsolete Management
- ✓ Cost Control Management
- ✓ Shortage Management
- ✓ Alternative Solution
- ✓ Excess Inventory Management