



THE DATASHEET OF ACPM-5004



ACPM-5004-TR1

Multimode PA - UMTS 1700MHz PA (1710-1785MHz)

3x3mm Power Amplifier Module with Coupler



Data Sheet

Description

The ACPM-5004-TR1 is a fully matched 10-pin surface mount module developed to support multimode applications including UMTS Band4/9 and CDMA AWS band. The ACPM-5004-TR1 meets stringent linearity requirements up to 28.4dBm output power for UMTS Rel.99 and 28.0dBm for CDMA. The 3mmx3mm form factor package is self contained, incorporating 50ohm input and output matching networks. The PA also contains internal DC blocking capacitors for RF input and output ports.

The ACPM-5004-TR1 features 5th generation of CoolPAM (CoolPAM5) circuit technology which supports 3 power modes – active bypass, mid power and high power modes. The CoolPAM is stage bypass technology enhancing PAE (power added efficiency) at low and medium power range. The active bypass feature is added to CoolPAM5 to enhance the PAE further at low output range and it enables the PA to have exceptionally low quiescent current. It dramatically saves the average power consumption and accordingly extends the talk time of mobiles and prolongs a battery life.

A directional coupler is integrated into the module and both coupling and isolation ports are available externally, supporting daisy chain. The integrated coupler has excellent coupler directivity, which minimizes the coupled output power variation or delivered power variation caused by the load mismatch from the antenna. The coupler directivity, or the output power variation into the mismatched load, is critical to the TRP and SAR performance of the mobile phones in real field operations as well as compliance tests for the system specifications.

The ACPM-5004 has integrated on-chip Vref and on-module bias switch as the one of the key features of the CoolPAM-5, so an external constant voltage source is not required, eliminating the external LDO regulators and switches from circuit boards of mobile devices. It also makes the PA fully digital-controllable by the Ven pin that simply turns the PA on and off from the digital control logic input from baseband chipsets. All of the digital control input pins

Features

- Thin Package (0.9mm typ)
- Excellent Linearity
- 3-mode power control with Vbp and Vmode
 - Bypass / Mid Power Mode / High Power Mode
- High Efficiency at max output power
- 10-pin surface mounting package
- Internal 50ohm matching networks for both RF input and output
- Integrated coupler
 - Coupler and Isolation ports for daisy chain
- Lead-free, RoHS compliant, Green

Applications

- UMTS (WCDMA, HSDPA, HSUPA, HSPA+)
- LTE
- CDMA

Ordering Information

| Part Number | Number of Devices | Container |
|---------------|-------------------|-------------------------|
| ACPM-5004-TR1 | 1000 | 178mm (7") Tape/Reel |
| ACPM-5004-BLK | 100 | Bulk |

Description (Cont.)

such as the Ven, Vmode and Vbp are fully CMOS compatible and can operate down to the 1.35V logic. The current consumption by digital control pins is negligible.

The power amplifier is manufactured on an advanced InGaP HBT (hetero-junction Bipolar Transistor) MMIC (microwave monolithic integrated circuit) technology offering state-of-the-art reliability, temperature stability and ruggedness.

Absolute Maximum Ratings

No damage assuming only one parameter is set at limit at a time with all other parameters set at or below nominal value.

Operation of any single parameter outside these conditions with the remaining parameters set at or below nominal values may result in permanent damage.

| Description | Min. | Typ. | Max. | Unit |
|--------------------------------|------|------|------|------|
| RF Input Power (Pin) | | 0 | 10 | dBm |
| DC Supply Voltage (Vcc1, Vcc2) | 0 | 3.4 | 5.0 | V |
| Enable Voltage (Ven) | 0 | 2.6 | 3.3 | V |
| Mode Control Voltage (Vmode) | 0 | 2.6 | 3.3 | V |
| Bypass Control (Vbp) | 0 | 2.6 | 3.3 | V |
| Storage Temperature (Tstg) | -55 | 25 | +125 | °C |

Recommended Operating Condition

| Description | Min. | Typ. | Max. | Unit | |
|--------------------------------|------|------|------|------|----|
| DC Supply Voltage (Vcc1, Vcc2) | 3.2 | 3.4 | 4.2 | V | |
| Enable Voltage (Ven) | Low | 0 | 0.5 | V | |
| | High | 1.35 | 3.1 | V | |
| Mode Control Voltage (Vmode) | Low | 0 | 0.5 | V | |
| | High | 1.35 | 3.1 | V | |
| Bypass Control Voltage (Vbp) | Low | 0 | 0.5 | V | |
| | High | 1.35 | 3.1 | V | |
| Operating Frequency (fo) | 1710 | | 1785 | MHz | |
| Ambient Temperature (Ta) | UMTS | -20 | 25 | 85 | °C |
| | CDMA | -30 | 25 | 85 | °C |

Operating Logic Table

| Power Mode | Ven | Vmode | Vbp | Pout (Rel99) | Pout (HSDPA, HSUPA MPR=0dB) |
|-----------------|------|-------|------|--------------|-----------------------------|
| High Power Mode | High | Low | X | ~ 28.6 dBm | ~ 27.6 dBm |
| Mid Power Mode | High | High | Low | ~ 17 dBm | ~ 16 dBm |
| Bypass Mode | High | High | High | ~ 7 dBm | ~ 6 dBm |
| Shut Down Mode | Low | Low | Low | - | - |

Electrical Characteristics for WCDMA Mode

– Conditions: Vcc = 3.4V, Ven = 2.6V, Ta = 25°C, Zin/Zout = 50ohm

– Signal Configuration: 3GPP (DPCCH + 1DPDCH) Up-Link unless specified otherwise.

| Characteristics | Condition | Min. | Typ. | Max. | Unit |
|---|--|-------------------------------|--------|-------|--------|
| Operating Frequency Range | | 1710 | – | 1785 | MHz |
| Maximum Output Power (High Power Mode) | Rel99 | 28.6 | | | dBm |
| | HSDPA, HSUPA MPR=0dB | 27.6 | | | dBm |
| | CDMA2000 RC1 | 28 | | | dBm |
| Gain | High Power Mode, Pout=28.6dBm | 24.5 | 26.5 | | dB |
| | Mid Power Mode, Pout=17dBm | 14 | 18 | | dB |
| | Bypass Mode, Pout=7dBm | 8 | 12 | | dB |
| Power Added Efficiency | High Power Mode, Pout=28.6dBm | 36.7 | 40.1 | | % |
| | Mid Power Mode, Pout=17dBm | 15.3 | 20.1 | | % |
| | Bypass Mode, Pout=7dBm | 6.9 | 12.6 | | % |
| Total Supply Current | High Power Mode, Pout=28.6dBm | | 530 | 580 | mA |
| | Mid Power Mode, Pout=17dBm | | 72 | 95 | mA |
| | Mid Power Mode, Pout=13.5dBm | | 50 | | mA |
| | Bypass Mode, Pout=7dBm | | 11 | 20 | mA |
| | Bypass Mode, Pout=3.5dBm | | 8.5 | | mA |
| Quiescent Current | High Power Mode | 85 | 117 | 150 | mA |
| | Mid Power Mode | 10 | 20 | 30 | mA |
| | Bypass Mode | 1 | 3.1 | 5 | mA |
| Enable Current | High Power Mode | | 5 | | μA |
| | Mid Power Mode | | 5 | | μA |
| | Bypass Mode | | 5 | | μA |
| Mode Control Current | Mid Power Mode | | 5 | | μA |
| | Bypass Mode | | 5 | | μA |
| Bypass Control Current | Bypass | | 5 | | μA |
| Total Current in Power-down mode | Ven=0V, Vmode=0V, Vbp=0V | | | 5 | μA |
| UMTS Adjacent Channel Leakage Ratio (ACLR) | 5 MHz offset 10 MHz offset | | | | |
| | | | -41 | -36 | dBc |
| | | | -54 | -46 | dBc |
| LTE ACLR | LTE to LTE, E-UTRA _{ACLR} Pout ≤ (maximum power – MPR) | | | -33 | dBc |
| | UTRA _{ACLR1} Pout ≤ (maximum power – MPR) | | | -36 | dBc |
| | UTRA _{ACLR2} Pout ≤ (maximum power – MPR) | | | -39 | dBc |
| Adjacent Channel Power Ratio (ACPR) | ±1.25 MHz offset ±1.98 MHz offset | | | | |
| | | | -52 | -44 | dBc |
| | | | -61 | -53 | dBc |
| Harmonic Suppression | Second Third | High Power Mode, Pout=28.6dBm | | | |
| | | | -40 | -35 | dBc |
| | | | -62 | -42 | dBc |
| Input VSWR | | | | 2.5:1 | |
| Stability (Spurious Output) | VSWR 5:1, All phase | | | -60 | dBc |
| Rx band Noise Power (B4, 2110-2170MHz, Vcc=4.2V) | High Power Mode, Pout=28.6dBm | | -142 | | dBm/Hz |
| Rx band Noise Power (B9, 1840-1879.9MHz, Vcc=4.2V) | High Power Mode, Pout=28.6dBm | | -135.5 | | dBm/Hz |
| Rx band Noise Power (B3, 1805-1879.9MHz, Vcc=4.2V) | High Power Mode, Pout=28.6dBm | | -135.5 | | dBm/Hz |
| Rx band gain (B4, 2110-2174MHz) | Where G is gain in Tx band | | G-6 | | dB |
| Rx band gain (B9, 1840-1879.9MHz Hz) | Where G is gain in Tx band | | G-1 | | dB |
| GPS Band Noise Power (1574-1577MHz, Vcc=4.2V) | High Power Mode, Pout=28.6dBm | | -135.5 | | dBm/Hz |

Continued on next page...

Electrical Characteristics for WCDMA Mode (continued)

| | | | |
|--|---|-------|--------|
| GPS Band Gain | Where G is gain in Tx band | G-2 | dB |
| GLONASS band gain | Where G is gain in Tx band | G-1 | dB |
| ISM band Noise Power (2400-2483.5MHz, Vcc=4.2V) | High Power Mode, Pout=28.6dBm | -150 | dBm/Hz |
| ISM Band Gain | Where G is gain in Tx band | G-20 | dB |
| Media band gain (716-728MHz) | Where G is gain in Tx band | G-23 | dB |
| PCS Rx band gain (1930-1990MHz) | Where G is gain in Tx band | G-2.5 | dB |
| Phase Discontinuity | low power mode to mid power mode, at Pout=7dBm | 44 | deg |
| | mid power mode to high power mode, at Pout=17dBm | -10 | deg |
| Ruggedness | Pout<28.6dBm, Pin<10dBm, All phase High Power Mode | 10:1 | VSWR |
| Coupling factor | RF Out to CPL port | 20 | dB |
| Daisy Chain Insertion Loss | ISO port to CPL port, Ven=Low | 0.25 | dB |

HSDPA Signal configuration used:

3GPP TS 34.121-1

Annex C (normative e): Measurement channels

C.10.1 UL reference measurement channel for HSDPA tests

Table C.10.1.4: β values for transmitter characteristics tests with HS-DPCCH

Sub-test 2 (CM=1.0, MPR=0.0)

HSUPA signal configuration used:

3GPP TS 34.121-1

Annex C (normative): Measurement channels

C.11.1 UL reference measurement channel for E-DCH tests

Table C.11.1.3: β values for transmitter characteristics tests with HS-DPCCH and E-DCH Sub-test 1 (CM=1.0, MPR=0.0)

At 3.2V operation, 0.5dB backoff is allowed for maximum power output.

Footprint

All dimensions are in millimeter

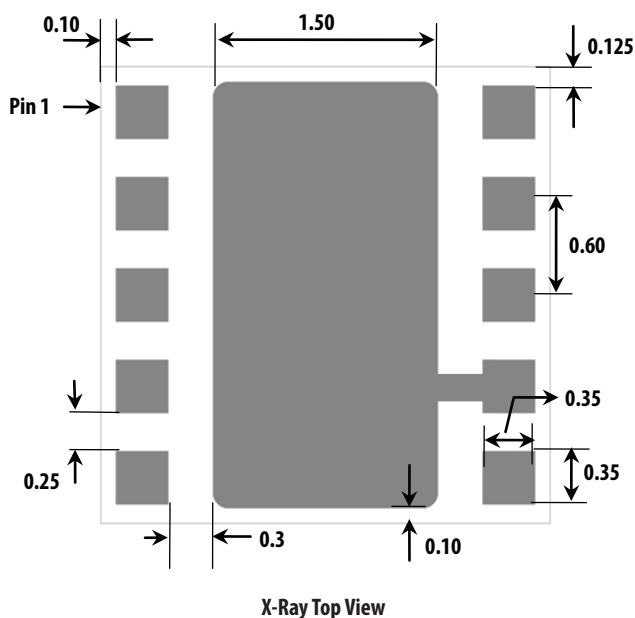

PIN Description

| Pin # | Name | Description |
|-------|-------|---------------------------|
| 1 | Vcc1 | DC Supply Voltage |
| 2 | RFin | RF Input |
| 3 | Vbp | Bypass Control |
| 4 | Vmode | Mode Control |
| 5 | Ven | PA Enable |
| 6 | CPL | Coupling port of Coupler |
| 7 | GND | Ground |
| 8 | ISO | Isolation port of Coupler |
| 9 | RFOut | RF Out |
| 10 | Vcc2 | DC Supply Voltage |

Package Dimensions

All dimensions are in millimeter

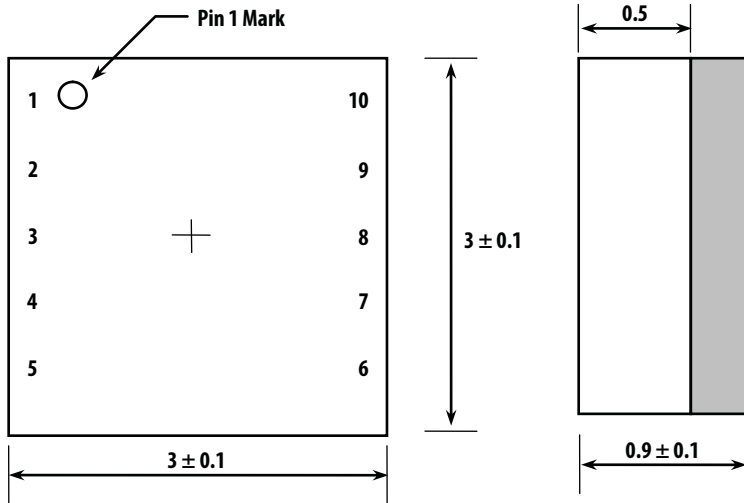

Marking Specification

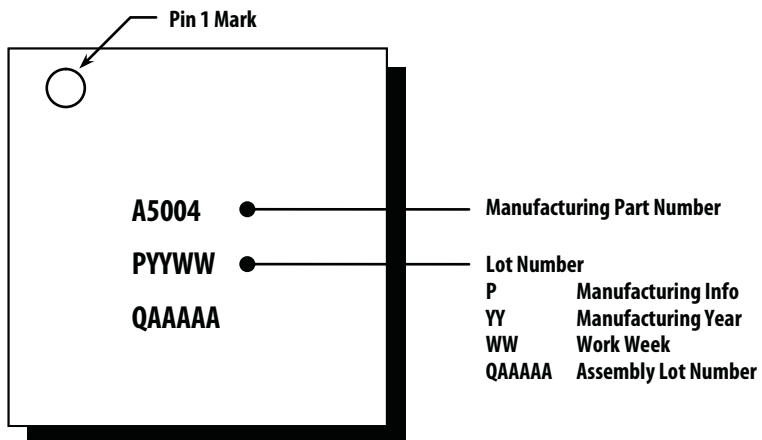

Metallization

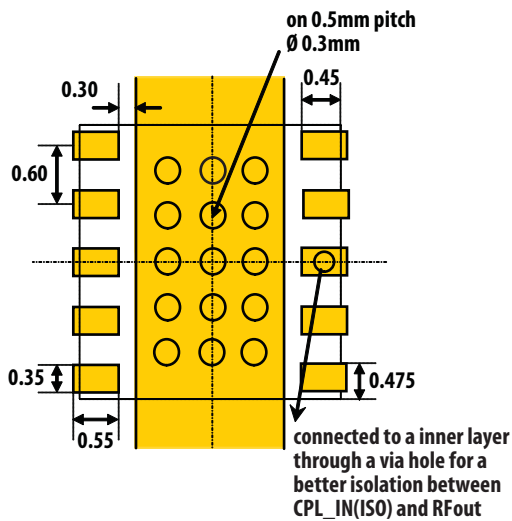

PCB Design Guidelines

The recommended PCB land pattern is shown in figures on the left side. The substrate is coated with solder mask between the I/O and conductive paddle to protect the gold pads from short circuit that is caused by solder bleeding/bridging.

Stencil Design Guidelines

A properly designed solder screen or stencil is required to ensure optimum amount of solder paste is deposited onto the PCB pads.

The recommended stencil layout is shown here. Reducing the stencil opening can potentially generate more voids. On the other hand, stencil openings larger than 100% will lead to excessive solder paste smear or bridging across the I/O pads or conductive paddle to adjacent I/O pads. Considering the fact that solder paste thickness will directly affect the quality of the solder joint, a good choice is to use laser cut stencil composed of 0.100mm(4mils) or 0.127mm(5mils) thick stainless steel which is capable of producing the required fine stencil outline.

Solder Mask Opening

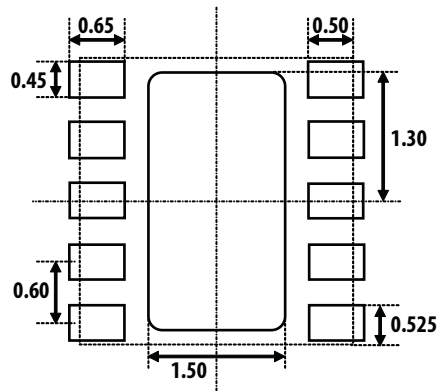

Solder Paste Stencil Aperture

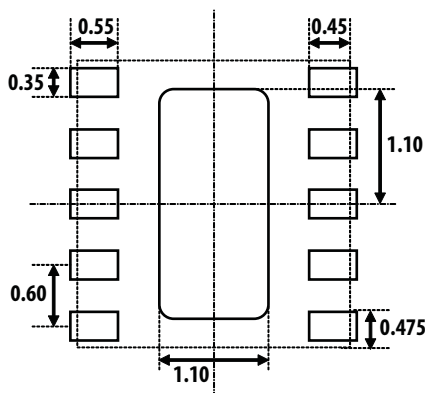

Evaluation Board Schematic

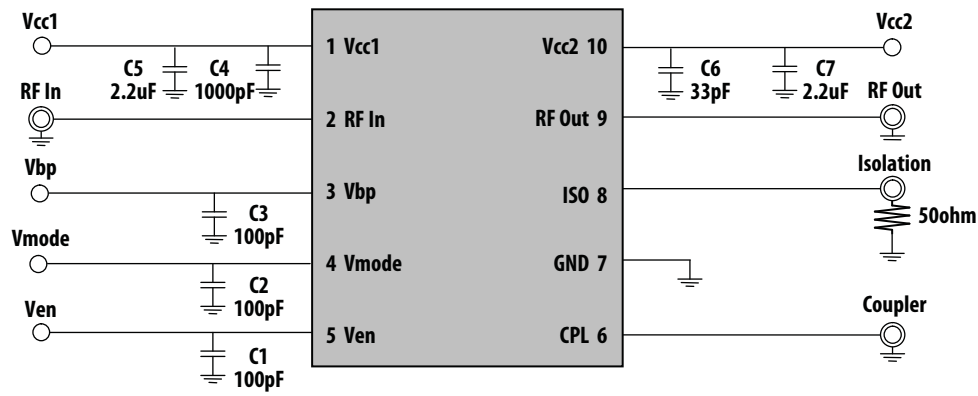

Evaluation Board Description

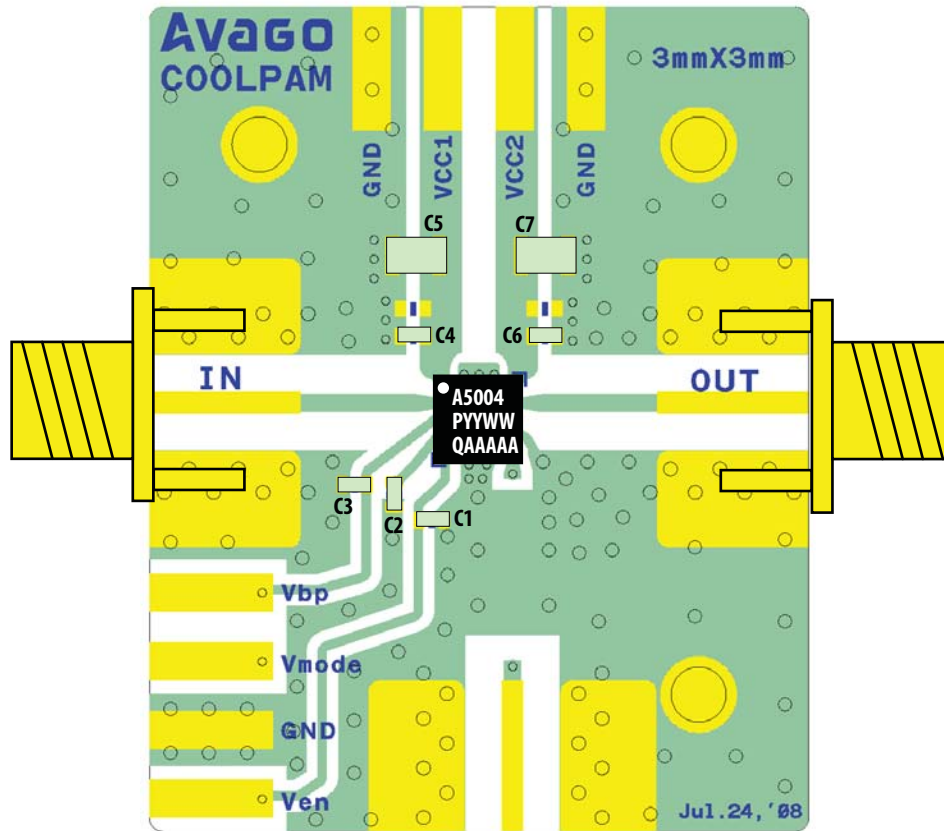

Tape and Reel Information

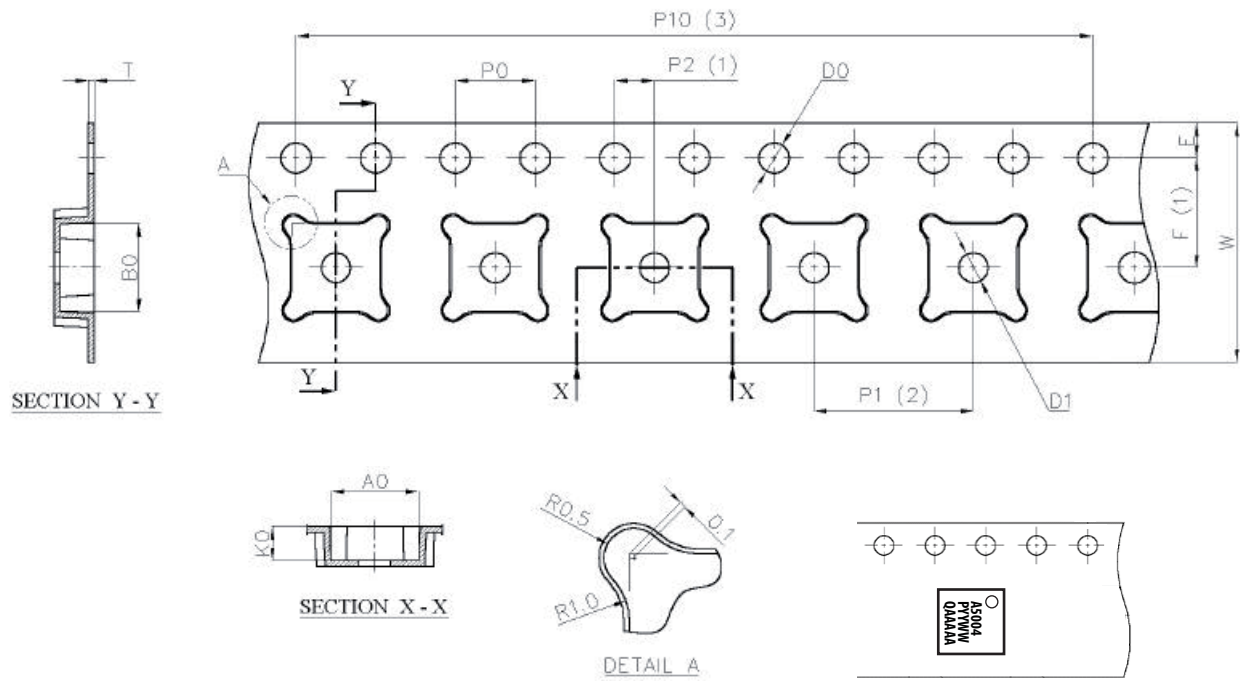

Dimension List

| Annote | Millimeter |
|--------|-----------------|
| A0 | 3.40 ± 0.10 |
| B0 | 3.40 ± 0.10 |
| K0 | 1.35 ± 0.10 |
| D0 | 1.55 ± 0.05 |
| D1 | 1.60 ± 0.10 |
| P0 | 4.00 ± 0.10 |
| P1 | 8.00 ± 0.10 |

| Annote | Millimeter |
|--------|------------------|
| P2 | 2.00 ± 0.05 |
| P10 | 40.00 ± 0.20 |
| E | 1.75 ± 0.10 |
| F | 5.50 ± 0.05 |
| W | 12.00 ± 0.30 |
| T | 0.30 ± 0.05 |

Tape and Reel Format – 3 mm x 3 mm

Reel Drawing

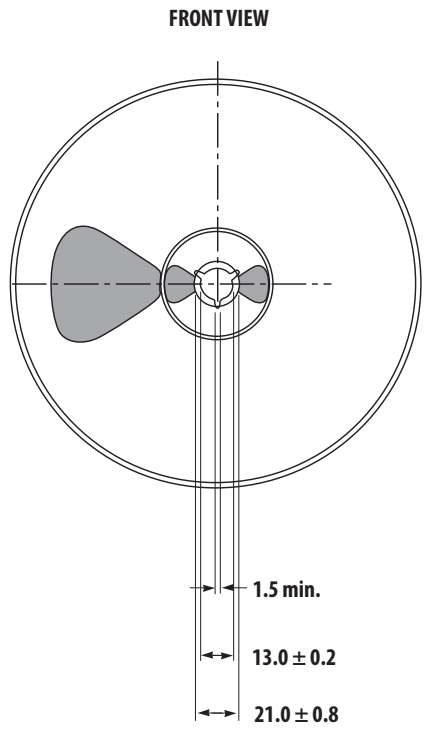
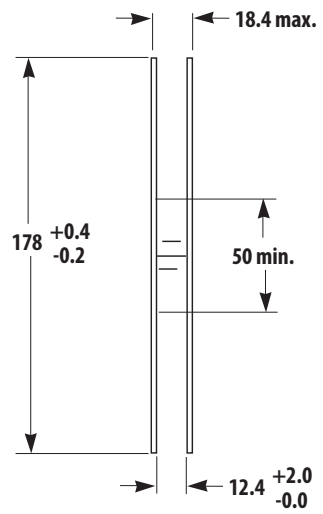
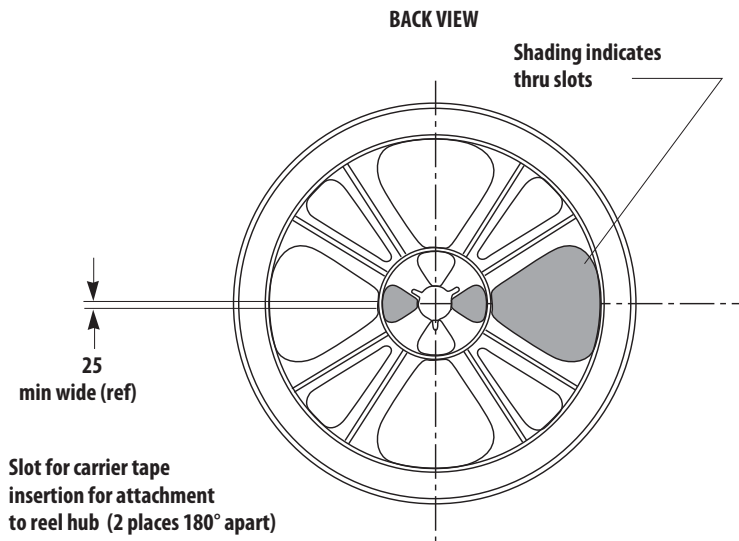

- NOTES:
1. Reel shall be labeled with the following information (as a minimum).
 - a. manufacturers name or symbol
 - b. Avago Technologies part number
 - c. purchase order number
 - d. date code
 - e. quantity of units
 2. A certificate of compliance (c of c) shall be issued and accompany each shipment of product.
 3. Reel must not be made with or contain ozone depleting materials.
 4. All dimensions in millimeters (mm)

Plastic Reel Format (all dimensions are in millimeters)

Handling and Storage

ESD (Electrostatic Discharge)

Electrostatic discharge occurs **naturally in the environment**. With the increase in voltage potential, the outlet of neutralization or discharge will be sought. If the acquired discharge route is **through a semiconductor device**, destructive damage will result.

ESD countermeasure methods should be developed and used to control potential ESD damage during handling in a factory environment at each manufacturing site.

MSL (Moisture Sensitivity Level)

Plastic encapsulated surface mount package is sensitive to damage induced by absorbed moisture and temperature.

Avago Technologies follows JEDEC Standard J-STD 020B. Each component and package type is classified for moisture sensitivity by soaking a known dry package at

various temperatures and relative humidity, and times. After soak, the components are subjected to three consecutive simulated reflows.

The out of bag exposure time maximum limits are determined by the classification test describe below which corresponds to a MSL classification level 6 to 1 according to the JEDEC standard IPC/JEDEC J-STD-020B and J-STD-033.

ACPM-5004-TR1 is MSL3. Thus, according to the J-STD-033 p.11 the maximum Manufacturers Exposure Time (MET) for this part is 168 hours. After this time period, the part would need to be removed from the reel, de-taped and then re-baked. MSL classification reflow temperature for the ACPM-5004-TR1 is targeted at 260°C +0/-5°C. Figure and table on next page show typical SMT profile for maximum temperature of 260 +0/-5°C.

Moisture Classification Level and Floor Life

| MSL Level | Floor Life (out of bag) at factory ambient =< 30°C/60% RH or as stated |
|-----------|--|
| 1 | Unlimited at =< 30°C/85% RH |
| 2 | 1 year |
| 2a | 4 weeks |
| 3 | 168 hours |
| 4 | 72 hours |
| 5 | 48 hours |
| 5a | 24 hours |
| 6 | Mandatory bake before use. After bake, must be reflowed within the time limit specified on the label |

Note :

1. The MSL Level is marked on the MSL Label on each shipping bag.

Reflow Profile Recommendations

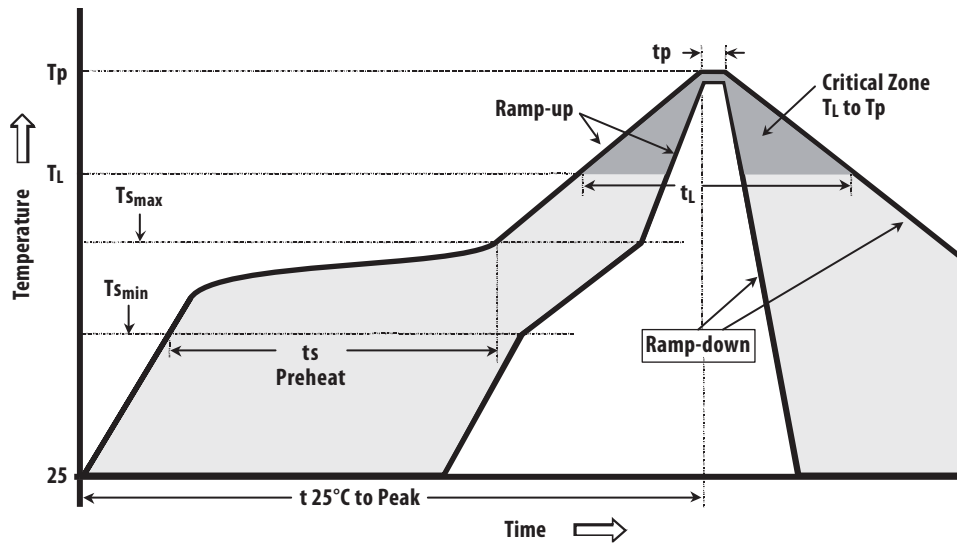

Typical SMT Reflow Profile for Maximum Temperature = $260 \pm 0/-5^\circ\text{C}$

Typical SMT Reflow Profile for Maximum Temperature = $260 \pm 0/-5^\circ\text{C}$

| Profile Feature | Sn-Pb Solder | Pb-Free Solder |
|--|------------------------------|------------------------------|
| Average ramp-up rate (TL to TP) | 3°C/sec max | 3°C/sec max |
| Preheat | | |
| – Temperature Min (T_{smin}) | 100°C | 150°C |
| – Temperature Max (T_{smax}) | 150°C | 200°C |
| – Time (min to max) (t_s) | 60-120 sec | 60-120 sec |
| T_{smax} to TL | | |
| – Ramp-up Rate | | 3°C/sec max |
| Time maintained above: | | |
| – Temperature (TL) | 183°C | 217°C |
| – Time (TL) | 60-150 sec | 60-150 sec |
| Peak temperature (T_p) | $240 \pm 0/-5^\circ\text{C}$ | $260 \pm 0/-5^\circ\text{C}$ |
| Time within 5°C of actual Peak Temperature (t_p) | 10-30 sec | 20-40 sec |
| Ramp-down Rate | 6°C/sec max | 6°C/sec max |
| Time 25°C to Peak Temperature | 6 min max. | 8 min max. |

Storage Condition

Packages described in this document must be stored in sealed moisture barrier, antistatic bags. Shelf life in a sealed moisture barrier bag is 12 months at <40°C and 90% relative humidity (RH) J-STD-033 p.7.

Out-of-Bag Time Duration

After unpacking the device must be soldered to the PCB within 168 hours as listed in the J-STD-020B p.11 with factory conditions <30°C and 60% RH.

Baking

It is not necessary to re-bake the part if both conditions (storage conditions and out-of-bag conditions) have been satisfied. Baking must be done if at least one of the conditions above have not been satisfied. The baking conditions are 125°C for 12 hours J-STD-033 p.8.

CAUTION

Tape and reel materials typically cannot be baked at the temperature described above. If out-of-bag exposure time is exceeded, parts must be baked for a longer time at low temperatures, or the parts must be de-reeled, de-taped, re-baked and then put back on tape and reel. (See moisture sensitive warning label on each shipping bag for information of baking).

Board Rework

Component Removal, Rework and Remount

If a component is to be removed from the board, it is recommended that localized heating be used and the maximum body temperatures of any surface mount component on the board not exceed 200°C. This method will minimize moisture related component damage. If any component temperature exceeds 200°C, the board must be baked dry per 4-2 prior to rework and/or component removal. Component temperatures shall be measured at the top center of the package body. Any SMD packages that have not exceeded their floor life can be exposed to a maximum body temperature as high as their specified maximum reflow temperature.

Removal for Failure Analysis

Not following the above requirements may cause moisture/reflow **damage that could hinder or completely prevent** the determination of the original failure mechanism.

Baking of Populated Boards

Some SMD packages and board materials are not able to withstand long duration bakes at 125°C. Examples of this are some FR-4 materials, which cannot withstand a 24 hr bake at 125°C. Batteries and electrolytic capacitors are also temperature sensitive. With component and board temperature restrictions in mind, choose a bake temperature from Table 4-1 in J-STD 033; then determine the appropriate bake duration based on the component to be removed. For additional considerations see IPC-7711 and IPC-7721.

Derating due to Factory Environmental Conditions

Factory floor life exposures for SMD packages removed from the dry bags will be a function of the ambient environmental conditions. A safe, yet conservative, handling approach is to expose the SMD packages only up to the maximum time limits for each moisture sensitivity level as shown in next table. This approach, however, does not work if the factory humidity or temperature is greater than the testing conditions of 30°C/60% RH. A solution for addressing this problem is to derate the exposure times based on the knowledge of moisture diffusion in the component package materials ref. JESD22-A120). Recommended equivalent total floor life exposures can be estimated for a range of humidities and temperatures based on the nominal plastic thickness for each device.

Table on next page lists equivalent derated floor lives for humidities ranging from 20-90% RH for three temperature, 20°C, 25°C, and 30°C.

Table on next page is applicable to SMDs molded with novolac, biphenyl or multifunctional epoxy mold compounds. The following assumptions were used in calculating this table:

1. Activation Energy for diffusion = 0.35eV (smallest known value).
2. For ≤60% RH, use Diffusivity = $0.121 \exp(-0.35\text{eV}/kT)$ mm²/s (this used smallest known Diffusivity @ 30°C).
3. For >60% RH, use Diffusivity = $1.320 \exp(-0.35\text{eV}/kT)$ mm²/s (this used largest known Diffusivity @ 30°C).

Recommended Equivalent Total Floor Life (days) @ 20°C, 25°C & 30°C, 35°C

For ICs with Novolac, Biphenyl and Multifunctional Epoxies (Reflow at same temperature at which the component was classified) Maximum Percent Relative Humidity

| Maximum Percent Relative Humidity | | | | | | | | | | | | |
|---|----------------------------|----|-----|-----|-----|-----|-----|-----|-----|-----|------|------|
| Package Type and Body Thickness | Moisture Sensitivity Level | 5% | 10% | 20% | 30% | 40% | 50% | 60% | 70% | 80% | 90% | |
| Body Thickness ≥3.1 mm Including PQFPs >84 pin, PLCCs (square) All MQFPs or All BGAs ≥1 mm | Level 2a | ∞ | ∞ | 94 | 44 | 32 | 26 | 16 | 7 | 5 | 4 | 35°C |
| | | ∞ | ∞ | 124 | 60 | 41 | 33 | 28 | 10 | 7 | 6 | 30°C |
| | | ∞ | ∞ | 167 | 78 | 53 | 42 | 36 | 14 | 10 | 8 | 25°C |
| | | ∞ | ∞ | 231 | 103 | 69 | 57 | 47 | 19 | 13 | 10 | 20°C |
| | Level 3 | ∞ | ∞ | 8 | 7 | 6 | 6 | 6 | 4 | 3 | 3 | 35°C |
| | | ∞ | ∞ | 10 | 9 | 8 | 7 | 7 | 5 | 4 | 4 | 30°C |
| | | ∞ | ∞ | 13 | 11 | 10 | 9 | 9 | 7 | 6 | 5 | 25°C |
| | | ∞ | ∞ | 17 | 14 | 13 | 12 | 12 | 10 | 8 | 7 | 20°C |
| | Level 4 | ∞ | 3 | 3 | 3 | 2 | 2 | 2 | 2 | 1 | 1 | 35°C |
| | | ∞ | 5 | 4 | 4 | 4 | 3 | 3 | 3 | 2 | 2 | 30°C |
| | | ∞ | 6 | 5 | 5 | 5 | 5 | 4 | 3 | 3 | 3 | 25°C |
| | | ∞ | 8 | 7 | 7 | 7 | 7 | 6 | 5 | 4 | 4 | 20°C |
| | Level 5 | ∞ | 2 | 2 | 2 | 2 | 1 | 1 | 1 | 1 | 1 | 35°C |
| | | ∞ | 4 | 3 | 3 | 2 | 2 | 2 | 2 | 1 | 1 | 30°C |
| | | ∞ | 5 | 5 | 4 | 4 | 3 | 3 | 2 | 2 | 2 | 25°C |
| | | ∞ | 7 | 7 | 6 | 5 | 5 | 4 | 3 | 3 | 3 | 20°C |
| Level 5a | ∞ | 1 | 1 | 1 | 1 | 1 | 1 | 1 | 1 | 1 | 35°C | |
| | ∞ | 2 | 1 | 1 | 1 | 1 | 1 | 1 | 1 | 1 | 30°C | |
| | ∞ | 3 | 2 | 2 | 2 | 2 | 2 | 1 | 1 | 1 | 25°C | |
| | ∞ | 5 | 4 | 3 | 3 | 3 | 2 | 2 | 2 | 2 | 20°C | |
| Body 2.1 mm ≤ Thickness <3.1 mm including PLCCs (rectangular) 18-32 pin SOICs (wide body) SOICs ≥20 pins, PQFPs ≤80 pins | Level 2a | ∞ | ∞ | ∞ | ∞ | 58 | 30 | 22 | 3 | 2 | 1 | 35°C |
| | | ∞ | ∞ | ∞ | ∞ | 86 | 39 | 28 | 4 | 3 | 2 | 30°C |
| | | ∞ | ∞ | ∞ | ∞ | 148 | 51 | 37 | 6 | 4 | 3 | 25°C |
| | | ∞ | ∞ | ∞ | ∞ | ∞ | 69 | 49 | 8 | 5 | 4 | 20°C |
| | Level 3 | ∞ | ∞ | 12 | 9 | 7 | 6 | 5 | 2 | 2 | 1 | 35°C |
| | | ∞ | ∞ | 19 | 12 | 9 | 8 | 7 | 3 | 2 | 2 | 30°C |
| | | ∞ | ∞ | 25 | 15 | 12 | 10 | 9 | 5 | 3 | 3 | 25°C |
| | | ∞ | ∞ | 32 | 19 | 15 | 13 | 12 | 7 | 5 | 4 | 20°C |
| | Level 4 | ∞ | 5 | 4 | 3 | 3 | 2 | 2 | 1 | 1 | 1 | 35°C |
| | | ∞ | 7 | 5 | 4 | 4 | 3 | 3 | 2 | 2 | 1 | 30°C |
| | | ∞ | 9 | 7 | 5 | 5 | 4 | 4 | 3 | 2 | 2 | 25°C |
| | | ∞ | 11 | 9 | 7 | 6 | 6 | 5 | 4 | 3 | 3 | 20°C |
| | Level 5 | ∞ | 3 | 2 | 2 | 2 | 2 | 1 | 1 | 1 | 1 | 35°C |
| | | ∞ | 4 | 3 | 3 | 2 | 2 | 2 | 1 | 1 | 1 | 30°C |
| | | ∞ | 5 | 4 | 3 | 3 | 3 | 3 | 2 | 1 | 1 | 25°C |
| | | ∞ | 6 | 5 | 5 | 4 | 4 | 4 | 3 | 3 | 2 | 20°C |
| Level 5a | ∞ | 1 | 1 | 1 | 1 | 1 | 1 | 1 | 0.5 | 0.5 | 35°C | |
| | ∞ | 2 | 1 | 1 | 1 | 1 | 1 | 1 | 0.5 | 0.5 | 30°C | |
| | ∞ | 2 | 2 | 2 | 2 | 2 | 2 | 1 | 1 | 1 | 25°C | |
| | ∞ | 3 | 2 | 2 | 2 | 2 | 2 | 2 | 2 | 1 | 20°C | |
| Body Thickness <2.1 mm including SOICs <18 pin All TQFPs, TSOPs or All BGAs <1 mm body thickness | Level 2a | ∞ | ∞ | ∞ | ∞ | ∞ | ∞ | 17 | 1 | 0.5 | 0.5 | 35°C |
| | | ∞ | ∞ | ∞ | ∞ | ∞ | ∞ | 28 | 1 | 1 | 1 | 30°C |
| | | ∞ | ∞ | ∞ | ∞ | ∞ | ∞ | ∞ | 2 | 1 | 1 | 25°C |
| | | ∞ | ∞ | ∞ | ∞ | ∞ | ∞ | ∞ | 2 | 2 | 1 | 20°C |
| | Level 3 | ∞ | ∞ | ∞ | ∞ | ∞ | 8 | 5 | 1 | 0.5 | 0.5 | 35°C |
| | | ∞ | ∞ | ∞ | ∞ | ∞ | 11 | 7 | 1 | 1 | 1 | 30°C |
| | | ∞ | ∞ | ∞ | ∞ | ∞ | 14 | 10 | 2 | 1 | 1 | 25°C |
| | | ∞ | ∞ | ∞ | ∞ | ∞ | 20 | 13 | 2 | 2 | 1 | 20°C |
| | Level 4 | ∞ | ∞ | ∞ | 7 | 4 | 3 | 2 | 1 | 0.5 | 0.5 | 35°C |
| | | ∞ | ∞ | ∞ | 9 | 5 | 4 | 3 | 1 | 1 | 1 | 30°C |
| | | ∞ | ∞ | ∞ | 12 | 7 | 5 | 4 | 2 | 1 | 1 | 25°C |
| | | ∞ | ∞ | ∞ | 17 | 9 | 7 | 6 | 2 | 2 | 1 | 20°C |
| | Level 5 | ∞ | ∞ | 7 | 3 | 2 | 2 | 1 | 1 | 0.5 | 0.5 | 35°C |
| | | ∞ | ∞ | 13 | 5 | 3 | 2 | 2 | 1 | 1 | 1 | 30°C |
| | | ∞ | ∞ | 18 | 6 | 4 | 3 | 3 | 2 | 1 | 1 | 25°C |
| | | ∞ | ∞ | 26 | 8 | 6 | 5 | 4 | 2 | 2 | 1 | 20°C |
| Level 5a | ∞ | 7 | 2 | 1 | 1 | 1 | 1 | 1 | 0.5 | 0.5 | 35°C | |
| | ∞ | 10 | 3 | 2 | 1 | 1 | 1 | 1 | 1 | 0.5 | 30°C | |
| | ∞ | 13 | 5 | 3 | 2 | 2 | 2 | 1 | 1 | 1 | 25°C | |
| | ∞ | 18 | 6 | 4 | 3 | 2 | 2 | 2 | 2 | 1 | 20°C | |

For product information and a complete list of distributors, please go to our web site: www.avagotech.com

Avago, Avago Technologies, and the A logo are trademarks of Avago Technologies in the United States and other countries.
Data subject to change. Copyright © 2005-2011 Avago Technologies. All rights reserved.
AV02-2478EN - March 29, 2011



Looking for pricing, stock, or lifecycle information?

Click below to explore more details on WIN SOURCE:

 [View ACPM-5004](#) on WIN SOURCE

 [Broadcom Limited](#) Information

Optimize Your Supply Chain with WIN SOURCE Solutions

-  Global Sourcing Solution
-  Obsolete Management
-  Cost Control Management
-  Shortage Management
-  Alternative Solution
-  Excess Inventory Management