

General Description

The MIC4684 is a high-efficiency 200kHz stepdown (buck) switching regulator. Power conversion efficiency of above 85% is easily obtainable for a wide variety of applications. The MIC4684 achieves 2A of continuous current in an 8-lead SO (small outline) package at 60°C ambient temperature.

High efficiency is maintained over a wide output current range by utilizing a boost capacitor to increase the voltage available to saturate the internal power switch. As a result of this high efficiency, no external heat sink is required. The MIC4684, housed in an SO-8, can replace larger TO-220 and TO-263 packages in many applications.

The MIC4684 allows for a high degree of safety. It has a wide input voltage range of 4V to 30V (34V transient), allowing it to be used in applications where input voltage transients may be present. Built-in safety features include over-current protection, frequency-foldback short-circuit protection, and thermal shutdown.

The MIC4684 is available in an 8-lead SO package with a junction temperature range of -40°C to +125°C.

Features

- SO-8 package with 2A continuous output current
- Over 85% efficiency
- Fixed 200kHz PWM operation
- Wide 4V to 30V input voltage range
- Output voltage adjustable to 1.235V
- All surface mount solution
- Internally compensated with fast transient response
- Over-current protection
- Frequency foldback short-circuit protection
- Thermal shutdown

Applications

- Simple high-efficiency step-down regulator
- 5V to 3.3V/1.7A converter (60°C ambient)
- 12V to 1.8V/2A converter (60°C ambient)
- On-card switching regulator
- Dual-output ±5V converter
- Battery charger

Ordering Information

| Part Number | | Voltage | Junction Temp. Range | Package |
|-------------|-----------|---------|----------------------|---------|
| Standard | Pb-Free | | | |
| MIC4684BM | MIC4684YM | Adj | -40°C to +125°C | SOP-8 |

Typical Application

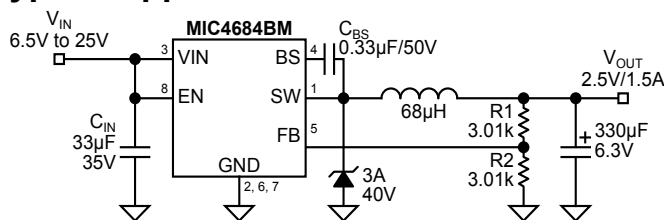

Adjustable Buck Converter

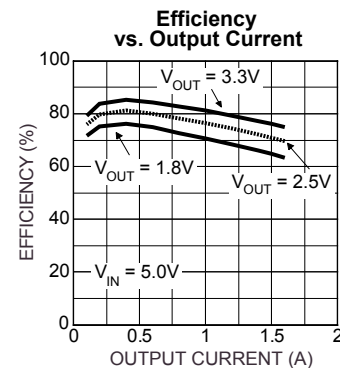

Efficiency vs. Output Current

Pin Configuration

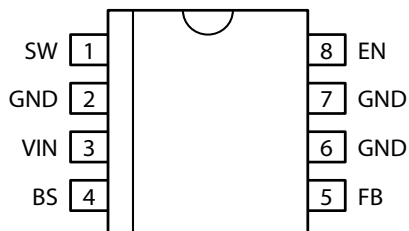

8-Pin SOP (M)

Pin Description

| Pin Number | Pin Name | Pin Function |
|------------|----------|---|
| 1 | SW | Switch (Output): Emitter of NPN output switch. Connect to external storage inductor and Schottky diode. |
| 2, 6, 7 | GND | Ground |
| 3 | IN | Supply (Input): Unregulated +4V to 30V supply voltage (34V transient) |
| 4 | BS | Bootstrap Voltage Node (External Component): Connect to external boost capacitor. |
| 5 | FB | Feedback (Input): Outback voltage feedback to regulator. Connect to output of supply for fixed versions. Connect to 1.23V tap of resistive divider for adjustable versions. |
| 8 | EN | Enable (Input): Logic high = enable; logic low = shutdown |

Detailed Pin Description

Switch (SW, pin 1)

The switch pin is tied to the emitter of the main internal NPN transistor. This pin is biased up to the input voltage minus the V_{SAT} of the main NPN pass element. The emitter is also driven negative when the output inductor's magnetic field collapses at turn-off. During the OFF time the SW pin is clamped by the output schottky diode to a $-0.5V$ typically.

Ground (GND, pins 2,6,7)

There are two main areas of concern when it comes to the ground pin, EMI and ground current. In a buck regulator or any other non-isolated switching regulator the output capacitor(s) and diode(s) ground is referenced back to the switching regulator's or controller's ground pin. Any resistance between these reference points causes an offset voltage/IR drop proportional to load current and poor load regulation. This is why its important to keep the output grounds placed as close as possible to the switching regulator's ground pin. To keep radiated EMI to a minimum its necessary to place the input capacitor ground lead as close as possible to the switching regulators ground pin.

Input Voltage (V_{IN} , pin 3)

The V_{IN} pin is the collector of the main NPN pass element. This pin is also connected to the internal regulator. The output diode or clamping diode should have its cathode as close as possible to this point to avoid voltage spikes adding to the voltage across the collector.

Bootstrap (BS, pin 4)

The bootstrap pin in conjunction with the external bootstrap capacitor provides a bias voltage higher than the input voltage to the MIC4684's main NPN pass element. The bootstrap capacitor sees the dv/dt of the switching action at the SW pin as an AC voltage. The bootstrap capacitor then couples the AC voltage back to the BS pin plus the dc offset of V_{IN} where it is rectified and used to provide additional drive to the main switch, in this case a NPN transistor.

This additional drive reduces the NPN's saturation voltage and increases efficiency, from a V_{SAT} of 1.8V, and 75% efficiency to a V_{SAT} of 0.5V and 88% efficiency respectively.

Feedback (FB, pin 5)

The feedback pin is tied to the inverting side of a GM error amplifier. The noninverting side is tied to a 1.235V bandgap reference. Fixed voltage versions have an internal voltage divider from the feedback pin. Adjustable versions require an external resistor voltage divider from the output to ground, with the center tied to the feedback pin.

Enable (EN, pin 8)

The enable (EN) input is used to turn on the regulator and is TTL compatible. Note: connect the enable pin to the input if unused. A logic-high enables the regulator. A logic-low shuts down the regulator and reduces the stand-by quiescent input current to typically 150 μA . The enable pin has an upper threshold of 2.0V minimum and lower threshold of 0.8V maximum. The hysteresis provided by the upper and lower thresholds acts as an UVLO and prevents unwanted turn on of the regulator due to noise.

Absolute Maximum Ratings (Note 1)

| | |
|--|-------------------|
| Supply Voltage (V_{IN}), Note 3 | +34V |
| Enable Voltage (V_{EN})..... | -0.3V to V_{IN} |
| Steady-State Output Switch Voltage (V_{SW})..... | -1V to V_{IN} |
| Feedback Voltage (V_{FB})..... | +12V |
| Storage Temperature (T_S)..... | -65°C to +150°C |
| ESD Rating..... | Note 3 |

Operating Ratings (Note 2)

| | |
|---|-----------------|
| Supply Voltage (V_{IN}) Note 4 | +4V to +30V |
| Ambient Temperature (T_A)..... | -40°C to +85°C |
| Junction Temperature (T_J)..... | -40°C to +125°C |
| Package Thermal Resistance | |
| θ_{JA} , Note 5 | 75°C/W |
| θ_{JC} , Note 5 | 25°C/W |

Electrical Characteristics

$V_{IN} = V_{EN} = 12V$, $V_{OUT} = 5V$; $I_{OUT} = 500mA$; $T_A = 25^\circ C$, unless otherwise noted. **Bold** values indicate $-40^\circ C \leq T_J \leq +125^\circ C$.

| Parameter | Condition | Min | Typ | Max | Units |
|-----------------------------|---|--------------|-------|--------------|---------|
| Feedback Voltage | ($\pm 2\%$) | 1.210 | 1.235 | 1.260 | V |
| | ($\pm 3\%$) | 1.198 | | 1.272 | V |
| | $8V \leq V_{IN} \leq 30V$, $0.1A \leq I_{LOAD} \leq 1A$, $V_{OUT} = 5V$ | 1.186 | 1.235 | 1.284 | V |
| | | 1.173 | | 1.297 | V |
| Feedback Bias Current | | | 50 | | nA |
| Maximum Duty Cycle | $V_{FB} = 1.0V$ | | 94 | | % |
| Output Leakage Current | $V_{IN} = 30V$, $V_{EN} = 0V$, $V_{SW} = 0V$ | | 5 | 500 | μA |
| | $V_{IN} = 30V$, $V_{EN} = 0V$, $V_{SW} = -1V$ | | 1.4 | 20 | mA |
| Quiescent Current | $V_{FB} = 1.5V$ | | 6 | 12 | mA |
| Bootstrap Drive Current | $V_{FB} = 1.5V$, $V_{SW} = 0V$ | 250 | 380 | | mA |
| Bootstrap Voltage | $I_{BS} = 10mA$, $V_{FB} = 1.5V$, $V_{SW} = 0V$ | 5.5 | 6.2 | | V |
| Frequency Fold Back | $V_{FB} = 0V$ | 30 | 50 | 120 | kHz |
| Oscillator Frequency | | 180 | 200 | 225 | kHz |
| Saturation Voltage | $I_{OUT} = 1A$ | | 0.59 | | V |
| Short Circuit Current Limit | $V_{FB} = 0V$, See <i>Test Circuit</i> | 2.2 | | | A |
| Shutdown Current | $V_{EN} = 0V$ | | 150 | | μA |
| Enable Input Logic Level | regulator on | 2 | | | V |
| | regulator off | | | 0.8 | V |
| Enable Pin Input Current | $V_{EN} = 0V$ (regulator off) | | 16 | 50 | μA |
| | $V_{EN} = 12V$ (regulator on) | -1 | -0.83 | | mA |
| Thermal Shutdown @ T_J | | | 160 | | °C |

Note 1. Exceeding the absolute maximum rating may damage the device.

Note 2. The device is not guaranteed to function outside its operating rating.

Note 3. Devices are ESD sensitive. Handling precautions recommended.

Note 4. 2.5V of headroom is required between V_{IN} and V_{OUT} . The headroom can be reduced by implementing a feed-forward diode as seen on the 5V to 3.3V circuit on page 1.

Note 5. Measured on 1" square of 1 oz. copper FR4 printed circuit board connected to the device ground leads.

Test Circuit

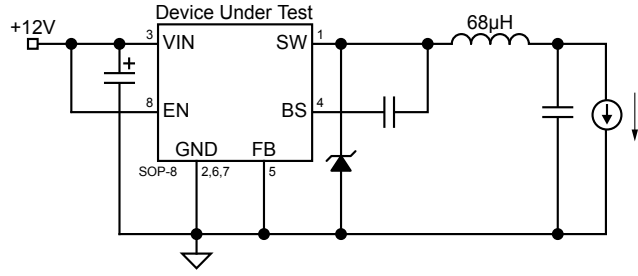

Current Limit Test Circuit

Shutdown Input Behavior

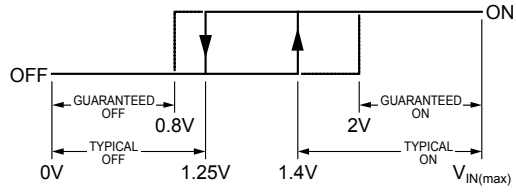

Enable Hysteresis

Typical Characteristics

($T_A = 25^\circ\text{C}$ unless otherwise noted)

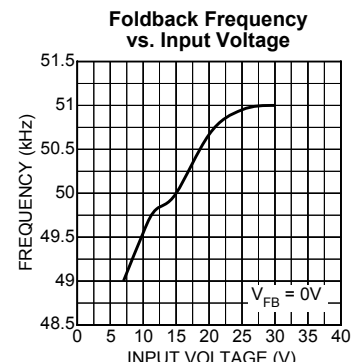
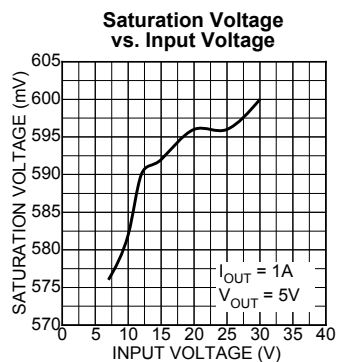
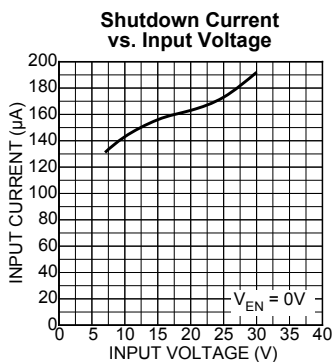
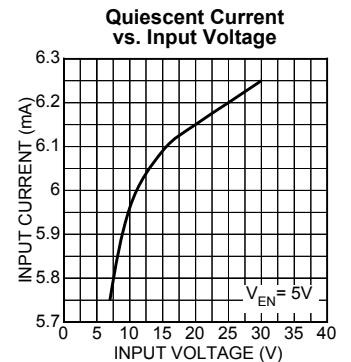
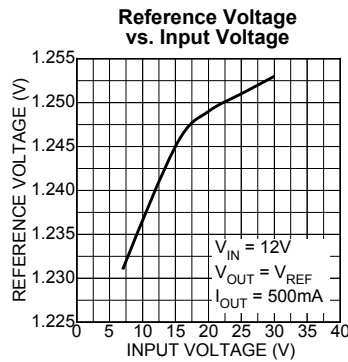
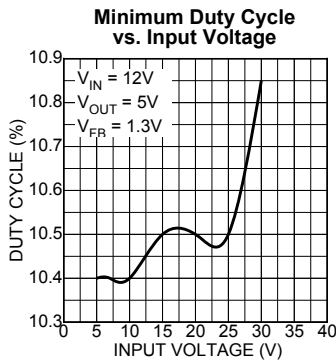
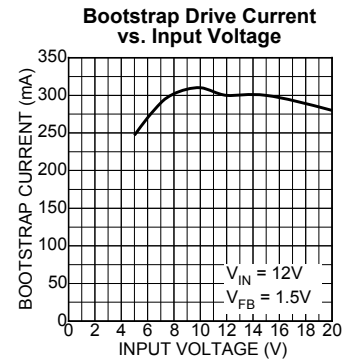
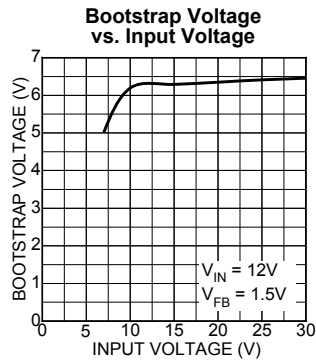
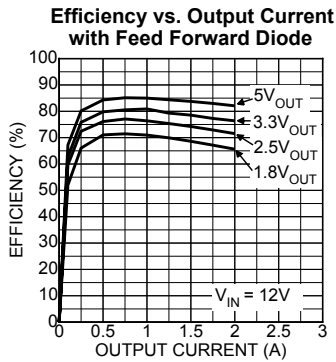
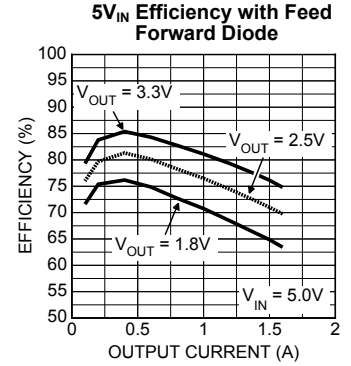
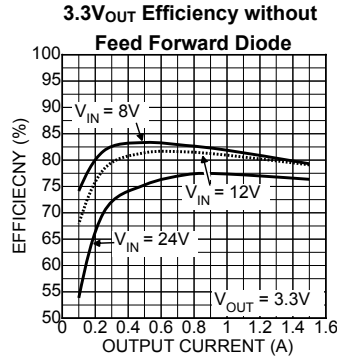
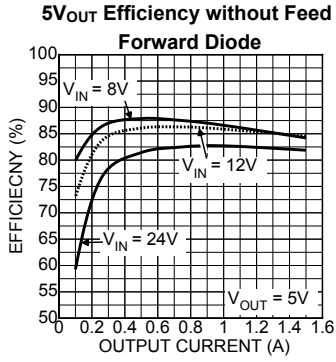

Feedback Voltage vs. Temperature

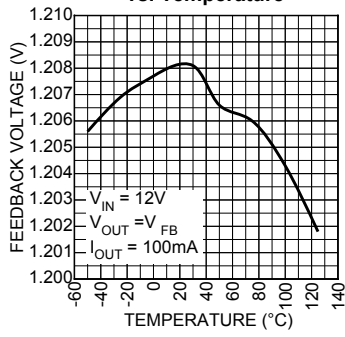

Shutdown Hysteresis vs. Temperature

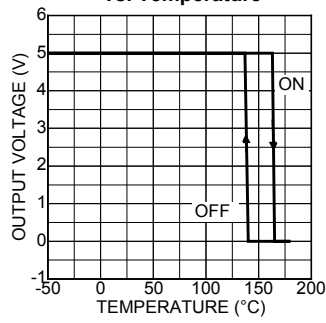

Load Regulation

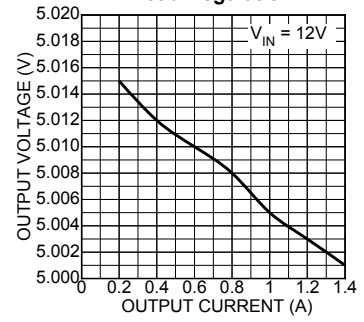

Line Regulation

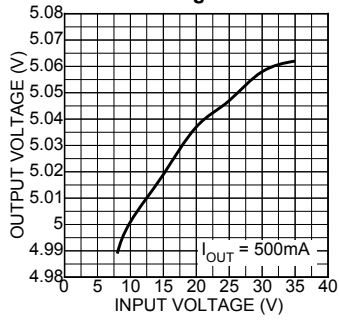

Enable Threshold vs. Temperature

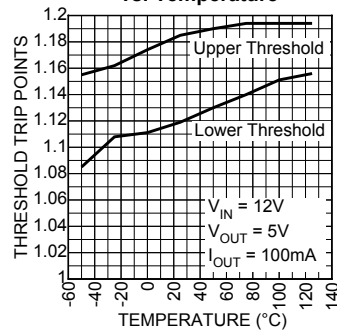

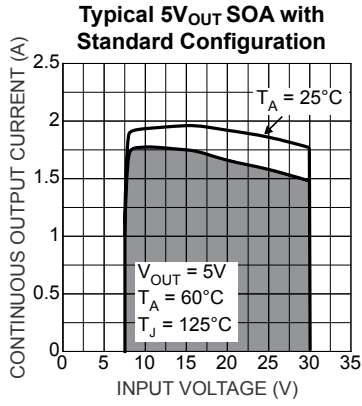

SOA Measured on the MIC4684 Evaluation Board.

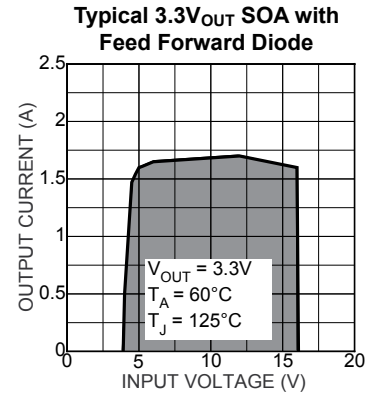

SOA Measured on the MIC4684 Evaluation Board.

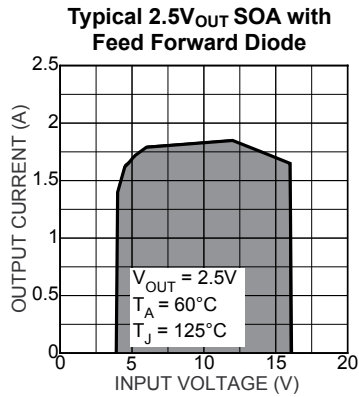

SOA measured on the MIC4684 Evaluation Board.

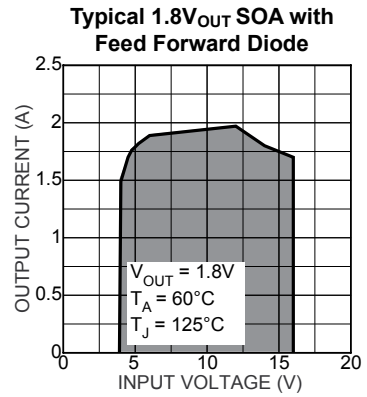

SOA measured on the MIC4684 Evaluation Board.

Functional Characteristics

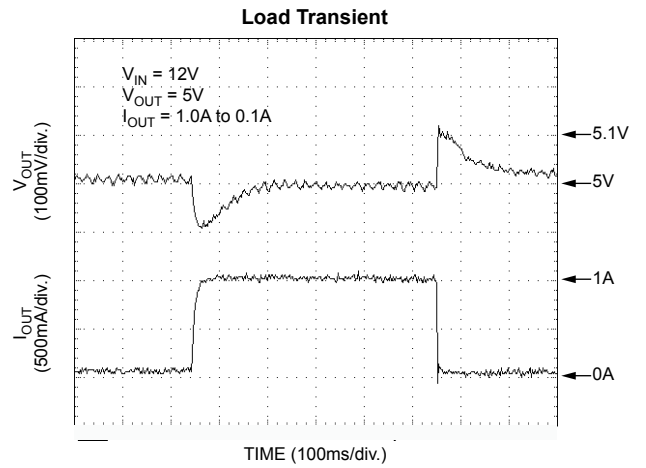
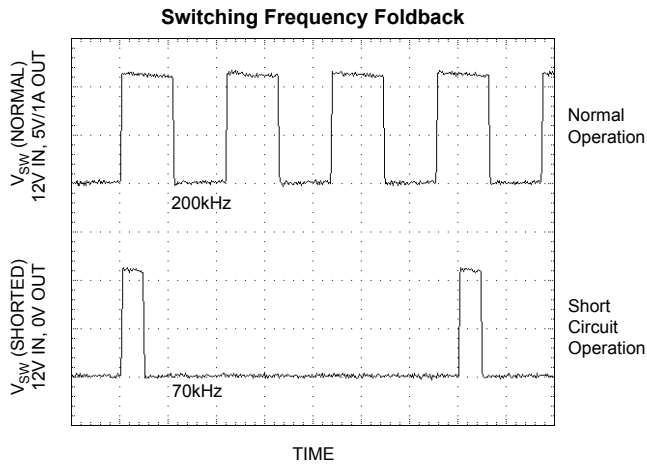

Frequency Foldback

The MIC4684 folds the switching frequency back during a hard short circuit condition to reduce the energy per cycle and protect the device.

Block Diagrams

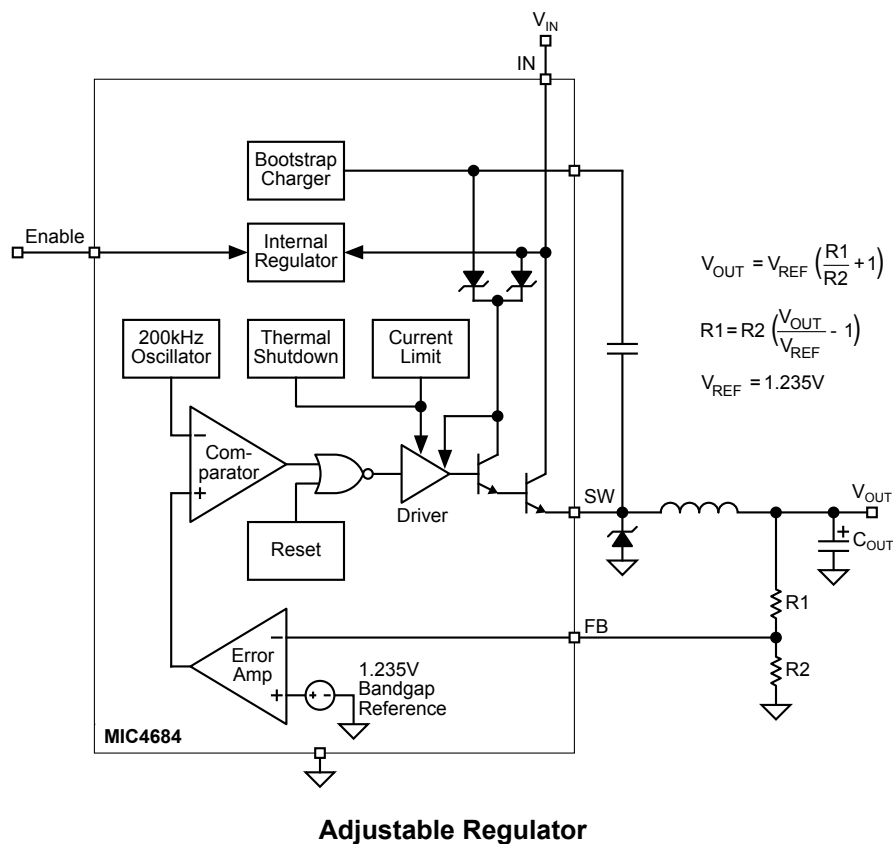

Functional Description

The MIC4684 is a variable duty cycle switch-mode regulator with an internal power switch. Refer to the above block diagram.

Supply Voltage

The MIC4684 operates from a +4V to +30V (34V transient) unregulated input. Highest efficiency operation is from a supply voltage around +12V. See the efficiency curves on page 5.

Enable/Shutdown

The enable (EN) input is TTL compatible. Tie the input high if unused. A logic-high enables the regulator. A logic-low shuts down the internal regulator which reduces the current to typically 150 μ A when $V_{EN} = 0V$.

Feedback

Fixed-voltage versions of the regulator have an internal resistive divider from the feedback (FB) pin. Connect FB directly to the output voltage.

Adjustable versions require an external resistive voltage divider from the output voltage to ground, center tapped to the FB pin. See Table 1 and Table 2 for recommended resistor values.

Duty Cycle Control

A fixed-gain error amplifier compares the feedback signal with a 1.235V bandgap voltage reference. The resulting error amplifier output voltage is compared to a 200kHz sawtooth

waveform to produce a voltage controlled variable duty cycle output.

A higher feedback voltage increases the error amplifier output voltage. A higher error amplifier voltage (comparator inverting input) causes the comparator to detect only the peaks of the sawtooth, reducing the duty cycle of the comparator output. A lower feedback voltage increases the duty cycle. The MIC4684 uses a voltage-mode control architecture.

Output Switching

When the internal switch is ON, an increasing current flows from the supply V_{IN} , through external storage inductor $L1$, to output capacitor C_{OUT} and the load. Energy is stored in the inductor as the current increases with time.

When the internal switch is turned OFF, the collapse of the magnetic field in $L1$ forces current to flow through fast recovery diode $D1$, charging C_{OUT} .

Output Capacitor

External output capacitor C_{OUT} provides stabilization and reduces ripple.

Return Paths

During the ON portion of the cycle, the output capacitor and load currents return to the supply ground. During the OFF portion of the cycle, current is being supplied to the output capacitor and load by storage inductor $L1$, which means that $D1$ is part of the high-current return path.

Applications Information

Adjustable Regulators

Adjustable regulators require a 1.23V feedback signal. Recommended voltage-divider resistor values for common output voltages are included in Table 1.

For other voltages, the resistor values can be determined using the following formulas:

$$V_{OUT} = V_{REF} \left(\frac{R1}{R2} + 1 \right)$$

$$R1 = R2 \left(\frac{V_{OUT}}{V_{REF}} - 1 \right)$$

$$V_{REF} = 1.235V$$

Minimum Pulse Width

The minimum duty cycle of the MIC4684 is approximately 10%. See *Minimum Duty Cycle Graph*. If this input-to-output voltage characteristic is exceeded, the MIC4684 will skip cycles to maintain a regulated V_{OUT} .

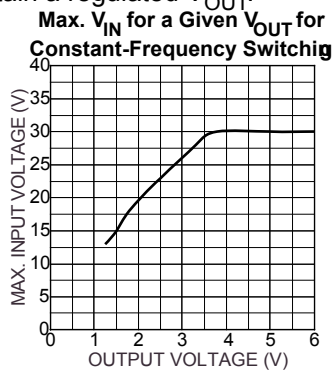

Figure 1. Minimum Pulse Width Characteristic

Thermal Considerations

The MIC4684 SuperSwitcher™ features the power-SOP-8. This package has a standard 8-lead small-outline package profile, but with much higher power dissipation than a standard SOP-8. Micrel’s MIC4684 SuperSwitcher™ family are the first dc-to-dc converters to take full advantage of this package.

The reason that the power SOP-8 has higher power dissipation (lower thermal resistance) is that pins 2, 6, and 7 and the die-attach paddle are a single piece of metal. The die is attached to the paddle with thermally conductive adhesive. This provides a low thermal resistance path from the junction of the die to the ground pins. This design significantly improves package power dissipation by allowing excellent heat transfer through the ground leads to the printed circuit board.

One limitation of the maximum output current on any MIC4684 design is the junction-to-ambient thermal resistance (θ_{JA}) of the design (package and ground plane).

Examining θ_{JA} in more detail:

$$\theta_{JA} = (\theta_{JC} + \theta_{CA})$$

where:

θ_{JC} = junction-to-case thermal resistance

θ_{CA} = case-to-ambient thermal resistance

θ_{JC} is a relatively constant 25°C/W for a power SOP-8.

θ_{CA} is dependent on layout and is primarily governed by the connection of pins 2, 6, and 7 to the ground plane. The purpose of the ground plane is to function as a heat sink.

θ_{JA} is ideally 75°C/W, but will vary depending on the size of the ground plane to which the power SOP-8 is attached.

Determining Ground-Plane Heat-Sink Area

Make sure that MIC4684 pins 2, 6, and 7 are connected to a ground plane with a minimum area of 6cm². This ground plane should be as close to the MIC4684 as possible. The area may be distributed in any shape around the package or on any pcb layer as long as there is good thermal contact to pins 2, 6, and 7. This ground plane area is more than sufficient for most designs.

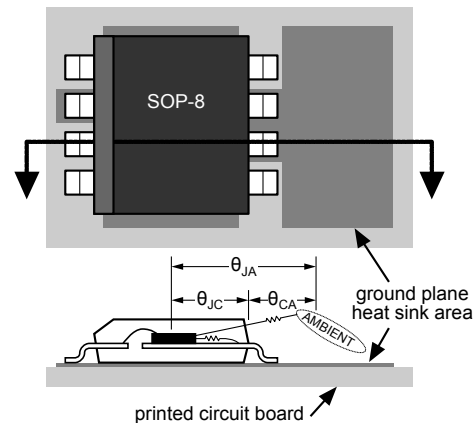

Figure 2. Power SOP-8 Cross Section

When designing with the MIC4684, it is a good practice to connect pins 2, 6, and 7 to the largest ground plane that is practical for the specific design.

Checking the Maximum Junction Temperature:

For this example, with an output power (P_{OUT}) of 5W, (5V output at 1A with $V_{IN} = 12V$) and 60°C maximum ambient temperature, what is the junction temperature?

Referring to the “Typical Characteristics: 5V Output Efficiency” graph, read the efficiency (η) for 1A output current at $V_{IN} = 12V$ or perform you own measurement.

$$\eta = 84\%$$

The efficiency is used to determine how much of the output power (P_{OUT}) is dissipated in the regulator circuit (P_D).

$$P_D = \frac{P_{OUT}}{\eta} - P_{OUT}$$

$$P_D = \frac{5W}{0.84} - 5W$$

$$P_D = 0.95W$$

A worst-case rule of thumb is to assume that 80% of the total output power dissipation is in the MIC4684 ($P_{D(IC)}$) and 20% is in the diode-inductor-capacitor circuit.

$$P_{D(IC)} = 0.8 P_D$$

$$P_{D(IC)} = 0.8 \times 0.95W$$

$$P_{D(IC)} = 0.76W$$

Calculate the worst-case junction temperature:

$$T_J = P_{D(IC)} \theta_{JC} + (T_C - T_A) + T_{A(max)}$$

where:

$$T_J = \text{MIC4684 junction temperature}$$

$$P_{D(IC)} = \text{MIC4684 power dissipation}$$

$$\theta_{JC} = \text{junction-to-case thermal resistance.}$$

The θ_{JC} for the MIC4684's power-SOP-8 is approximately 25°C/W.

T_C = "pin" temperature measurement taken at the entry point of pins 2, 6 or 7

$$T_A = \text{ambient temperature}$$

$T_{A(max)}$ = maximum ambient operating temperature for the specific design.

Calculating the maximum junction temperature given a maximum ambient temperature of 60°C:

$$T_J = 0.76 \times 25^\circ\text{C/W} + (41^\circ\text{C} - 25^\circ\text{C}) + 60^\circ\text{C}$$

$$T_J = 95^\circ\text{C}$$

This value is within the allowable maximum operating junction temperature of 125°C as listed in "Operating Ratings." Typical thermal shutdown is 160°C and is listed in *Electrical Characteristics*. Also see SOA curves on pages 7 through 8.

Layout Considerations

Layout is very important when designing any switching regulator. Rapidly changing currents through the printed circuit board traces and stray inductance can generate voltage transients which can cause problems.

To minimize stray inductance and ground loops, keep trace lengths as short as possible. For example, keep D1 close to pin 1 and pins 2, 6, and 7, keep L1 away from sensitive node FB, and keep C_{IN} close to pin 3 and pins 2, 6, and 7. See *Applications Information: Thermal Considerations* for ground plane layout.

The feedback pin should be kept as far away from the switching elements (usually L1 and D1) as possible.

A circuit with sample layouts are provided. See Figure 7. Gerber files are available upon request.

Feed Forward Diode

The FF diode (feed forward) provides an external bias source directly to the main pass element, this reduces V_{SAT} thus allowing the MIC4684 to be used in very low head-room applications I.E. $5V_{IN}$ to $3.3V_{OUT}$.

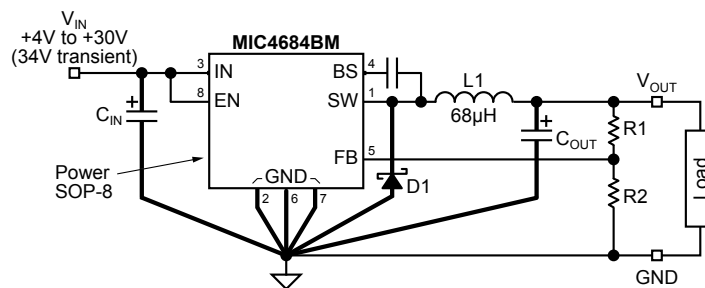

Figure 5. Critical Traces for Layout

Recommended Components for a Given Output Voltage (Feed-Forward Configuration)

$V_{IN} = 4V$ to $16V$ (in feed-forward configuration)

| V_{OUT} | I_{OUT} | R1 | R2 | V_{IN} | C_{IN} | D1 | D2 | L1 | C_{OUT} |
|-----------|-----------|-------|---------------|-------------------------|---|-----------------------------|--------------------------------|--|---|
| 5.0V | 1.6A | 3.01k | 976k Ω | 6.5V–16V | 47 μ F, 20V Vishay-Dale 595D476X0020D2T | 2A, 30V Schottky SS23 | 1A, 20V Schottky MBRX120 | 27 μ H Sumida CDH74-270MC | 120 μ F, 6.3V Vishay-Dale 594D127X06R3C2T |
| 3.3V | 1.7A | 3.01k | 1.78k | 4.85V–16V | 47 μ F, 20V Vishay-Dale 595D476X0020D2T | 2A, 30V Schottky SS23 | 1A, 20V Schottky MBRX120 | 27 μ H Sumida CDH74-270MC | 220 μ F, 6.3V Vishay-Dale 594D227X06R3C2T |
| 2.5V | 1.8A | 3.01k | 2.94k | 4.5V–16V Vishay-Dale | 47 μ F, 20V Schottky 595D476X0020D2T | 2A, 30V Schottky SS23 | 1A, 20V Schottky MBRX120 | 27 μ H Vishay-Dale CDH74-270MC | 330 μ F, 6.3V 594D337X06R3D2T |
| 1.8V | 2A | 3.01k | 6.49k | 4.2V–16V | 47 μ F, 20V Vishay-Dale 595D476X0020D2T | 2A, 30V Schottky SS23 | 1A, 20V Schottky MBRX120 | 27 μ H Sumida CDH74-270MC | 330 μ F, 6.3V Vishay-Dale 594D337X06R3D2T |

Note 1. This bill of materials assumes the use of feedforward schottky diode from V_{IN} to the bootstrap pin.

Table 1. Recommended Components for Common Output Voltages
($V_{IN} = 4V$ to $16V$)

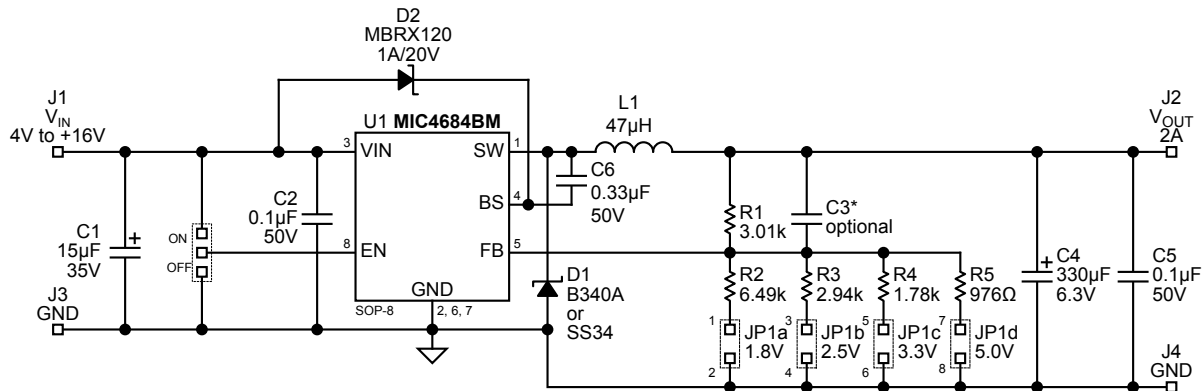

* C3 can be used to provide additional stability and improved transient response.
Note: optimized for 5V_{OUT}

Figure 6. 4V - 16V Input Evaluation Board Schematic Diagram

Printed Circuit Board

Evaluation Board Optimized for Low Input Voltage by using Feed-Forward Diode Configuration ($V_{IN} = 4V$ to $16V$)

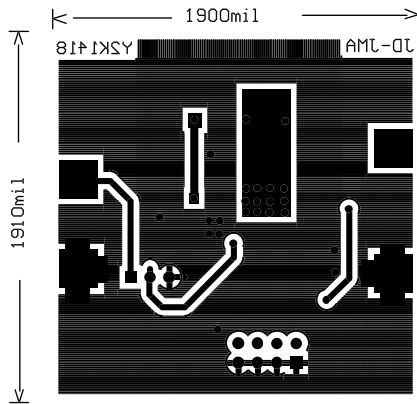

Figure 7a. Bottom Side Copper

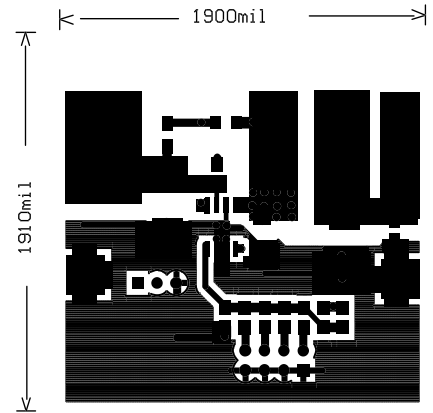

Figure 7b. Top Side Copper

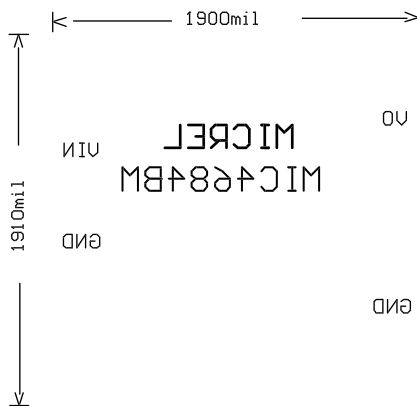

Figure 7c. Bottom Side Silk Screen

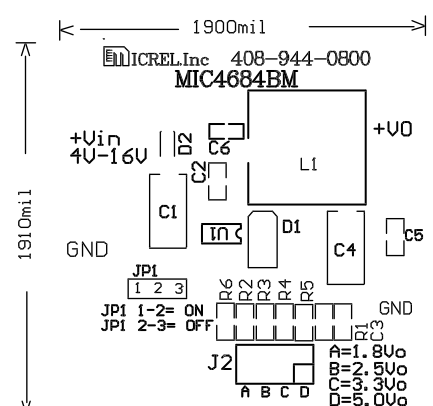

Figure 7d. Top Side Silk Screen

Abbreviated Bill of Material (Critical Components)

| Reference | Part Number | Manufacturer | Description | Qty |
|-----------|------------------|--------------------------------------|-------------------------------------|-----|
| C1 | 594D156X0035D2T | Vishay Sprague ⁽¹⁾ | 15 μ F 35V | 1 |
| C2, C5 | VJ0805Y104KXAAB | Vitramon | 0.1 μ F 50V | 2 |
| C6 | GRM426X7R334K50 | Murata | 0.33 μ F, 50V ceramic capacitor | |
| C3 | Optional | | 1800pF, 50V ceramic | (1) |
| C4 | 594D337X06R3D2T | Vishay Sprague ⁽²⁾ | 330 μ F, 6.3V, tantalum | 1 |
| D1 | B340A | Diode Inc ⁽³⁾ | Schottky 3A, 40V | 1 |
| D2 | MBRX120 | Micro Com. Components ⁽⁵⁾ | Schottky 1A, 20V | 1 |
| L1 | CDRH104R-470MC | Sumida ⁽⁴⁾ | 47 μ H, 2.1A I_{SAT} | 1 |
| U1 | MIC4684BM | Micrel, Inc. ⁽⁶⁾ | 1A 200kHz power-SO-8 buck regulator | 1 |

Notes:

1. Vishay Dale, Inc., tel: 1 402-644-4218, <http://www.vishay.com>
2. Vishay Sprague, Inc., tel: 1 207-490-7256, <http://www.vishay.com>
3. Diodes Inc, tel: (805) 446-4800, <http://www.diodes.com>
4. Sumida, tel: (408) 982-9960, <http://www.sumida.com>
5. Micro Commercial Components, tel: (800) 346-3371
6. Micrel, Inc. tel: (408) 944-0800, <http://www.micrel.com>

Recommended Components for a Given Output Voltage (Standard Configuration)

$V_{IN} = 4V \text{ to } 30V$

| V_{OUT} | I_{OUT} | R1 | R2 | V_{IN} | C_{IN} | D1 | L1 | C_{OUT} |
|-----------|-----------|-------|---------------|----------|---|-----------------------------|--|---|
| 5.0V | 1.7A | 3.01k | 976k Ω | 8V–30V | 33 μ F, 35V Vishay-Dale 595D336X0035R2T | 3A, 40V Schottky SS34 | 68 μ H Sumida CDRH104R-680MC | 120 μ F, 6.3V Vishay-Dale 594D127X06R3C2T |
| 3.3V | 1.5A | 3.01k | 1.78k | 7V–28V | 33 μ F, 35V Vishay-Dale 595D336X0035R2T | 3A, 40V Schottky SS34 | 68 μ H Sumida CDRH104R-680MC | 220 μ F, 6.3V Vishay-Dale 594D227X06R3C2T |
| 2.5V | 1.5A | 3.01k | 2.94k | 6.5V–23V | 33 μ F, 35V Vishay-Dale 595D336X0035R2T | 3A, 40V Schottky SS34 | 68 μ H Sumida CDRH104R-680MC | 330 μ F, 6.3V Vishay-Dale 594D337X06R3D2T |
| 1.8V | 1.5A | 3.01k | 6.49k | 6V–17V | 47 μ F, 25V Vishay-Dale 595D476X0025D2T | 3A, 40V Schottky SS34 | 68 μ H Sumida CDRH104R-680MC | 330 μ F, 6.3V Vishay-Dale 594D337X06R3D2T |

Table 2. Recommended Components for Common Output Voltages ($V_{IN} = 4V \text{ to } 30V$)

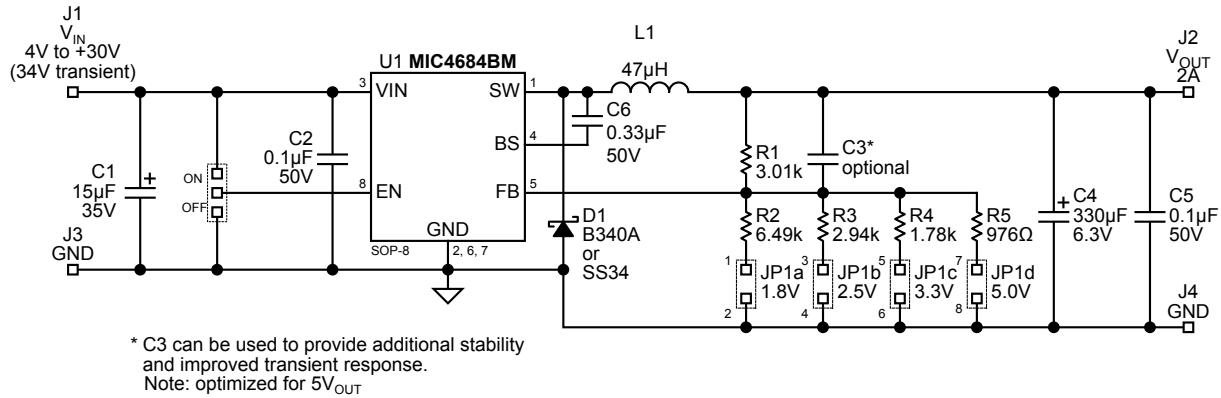

Figure 8. 4V - 30V Input Evaluation Board Schematic Diagram

Printed Circuit Board

General Purpose Evaluation Board ($V_{IN} = 4V$ to $30V$)

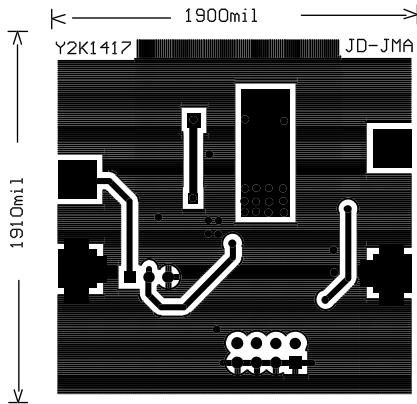

Figure 9a. Bottom Side Copper

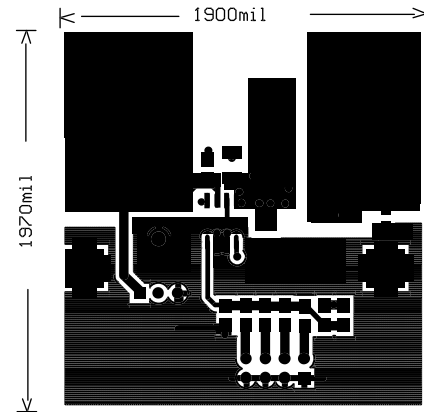

Figure 9b. Top Side Copper

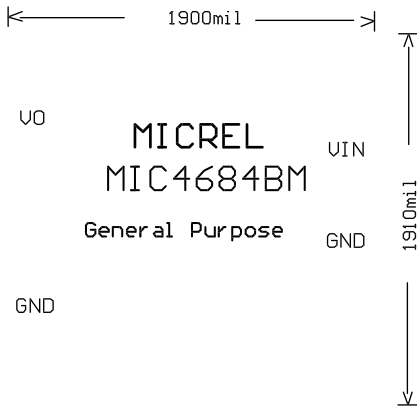

Figure 9c. Bottom Side Silk Screen

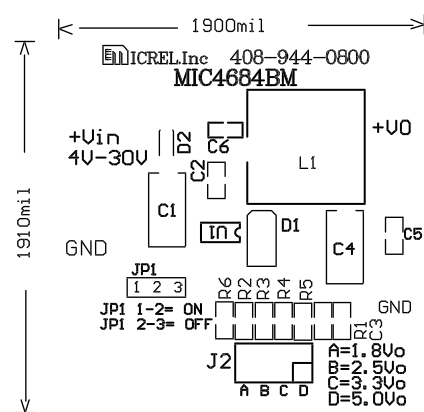

Figure 9d. Top Side Silk Screen

Abbreviated Bill of Material (Critical Components)

| Reference | Part Number | Manufacturer | Description | Qty |
|-----------|------------------|-------------------------------|-------------------------------------|-----|
| C1 | 594D156X0035D2T | Vishay Sprague ⁽¹⁾ | 15 μ F 35V | 1 |
| C2, C5 | VJ0805Y104KXAAB | Vitramon | 0.1 μ F 50V | 2 |
| C6 | GRM426X7R334K50 | Murata | 0.33 μ F, 50V ceramic capacitor | |
| C3 | Optional | | 1800pF, 50V ceramic | (1) |
| C4 | 594D337X06R3D2T | Vishay Sprague ⁽²⁾ | 330 μ F, 6.3V, tantalum | 1 |
| D1 | B340A | Diode Inc ⁽³⁾ | Schottky 3A 40V | 1 |
| L1 | CDRH104R-470MC | Sumida ⁽⁴⁾ | 47 μ H, 2.1A I_{SAT} | 1 |
| U1 | MIC4684BM | Micrel, Inc. ⁽⁵⁾ | 1A 200kHz power-SO-8 buck regulator | 1 |

Notes:

1. Vishay Dale, Inc., tel: 1 402-644-4218, <http://www.vishay.com>
2. Vishay Sprague, Inc., tel: 1 207-490-7256, <http://www.vishay.com>
3. Diodes Inc, tel: (805) 446-4800, <http://www.diodes.com>
4. Sumida, tel: (408) 982-9960, <http://www.sumida.com>
5. Micrel, Inc. tel: (408) 944-0800, <http://www.micrel.com>

Package Information

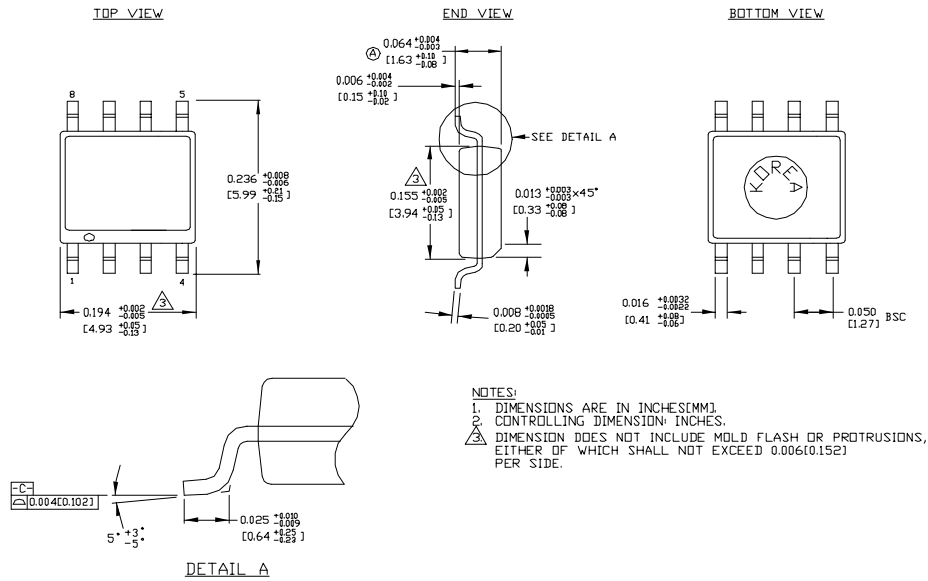

8-Lead SOP (M)

MICREL INC. 2180 FORTUNE DRIVE SAN JOSE, CA 95131 USA
 TEL + 1 (408) 944-0800 FAX + 1 (408) 474-1000 WEB <http://www.micrel.com>

This information furnished by Micrel in this data sheet is believed to be accurate and reliable. However no responsibility is assumed by Micrel for its use. Micrel reserves the right to change circuitry and specifications at any time without notification to the customer.

Micrel Products are not designed or authorized for use as components in life support appliances, devices or systems where malfunction of a product can reasonably be expected to result in personal injury. Life support devices or systems are devices or systems that (a) are intended for surgical implant into the body or (b) support or sustain life, and whose failure to perform can be reasonably expected to result in a significant injury to the user. A Purchaser's use or sale of Micrel Products for use in life support appliances, devices or systems is a Purchaser's own risk and Purchaser agrees to fully indemnify Micrel for any damages resulting from such use or sale.

Looking for pricing, stock, or lifecycle information?

Click below to explore more details on WIN SOURCE:

- ⊖ [View MIC4684BM on WIN SOURCE](#)
- ⊖ [Microchip Technology](#) Information

Optimize Your Supply Chain with WIN SOURCE Solutions

- ✓ Global Sourcing Solution
- ✓ Obsolete Management
- ✓ Cost Control Management
- ✓ Shortage Management
- ✓ Alternative Solution
- ✓ Excess Inventory Management