



**THE DATASHEET OF
HI171JCB-T**



Pb-Free and RoHS Compliant

HI1171

8-Bit, 40 MSPS, High Speed D/A Converter

FN3662
Rev.3.00
October 26, 2005

Features

- Throughput Rate.....40MHz
- Resolution.....8-Bit
- Integral Linearity Error.....0.25 LSB
- Low Glitch Noise
- Single Supply Operation.....+5V
- Low Power Consumption (Max).....80mW
- Evaluation Board Available (HI1171-EV)
- Direct Replacement for the Sony CXD1171

Applications

- Wireless Telecommunications
- Signal Reconstruction
- Direct Digital Synthesis
- Imaging
- Presentation and Broadcast Video
- Graphics Displays
- Signal Generators

Description

The HI1171 is an 8-bit, 40MHz, high speed D/A converter. The converter incorporates an 8-bit input data register with blanking capability, and current outputs. The HI1171 features low glitch outputs. The architecture is a current cell arrangement to provide low linearity errors. The HI1171 is available in an Industrial temperature range and is offered in a 24 lead (200 mil) SOIC plastic package. For dual version, please refer to the HI1177 Data Sheet. For triple version, please refer to the HI1178 Data Sheet.

Ordering Information

PART NUMBER	TEMP. RANGE (°C)	PACKAGE	PKG. NO.
HI1171JCB	-40 to 85	24 Ld SOIC	M24.2-S
HI1171-EV	25	Evaluation Board	

Pinout

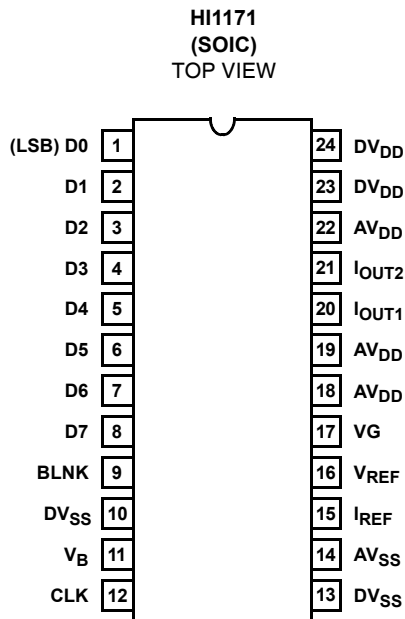

Typical Application Circuit

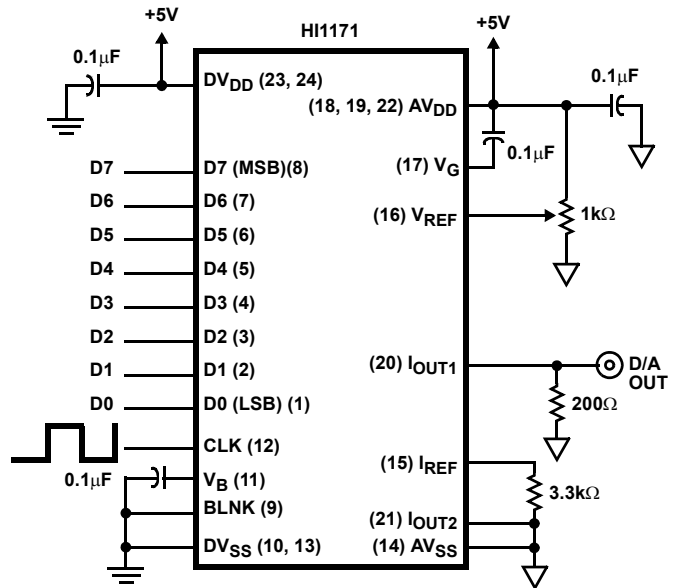

Functional Block Diagram

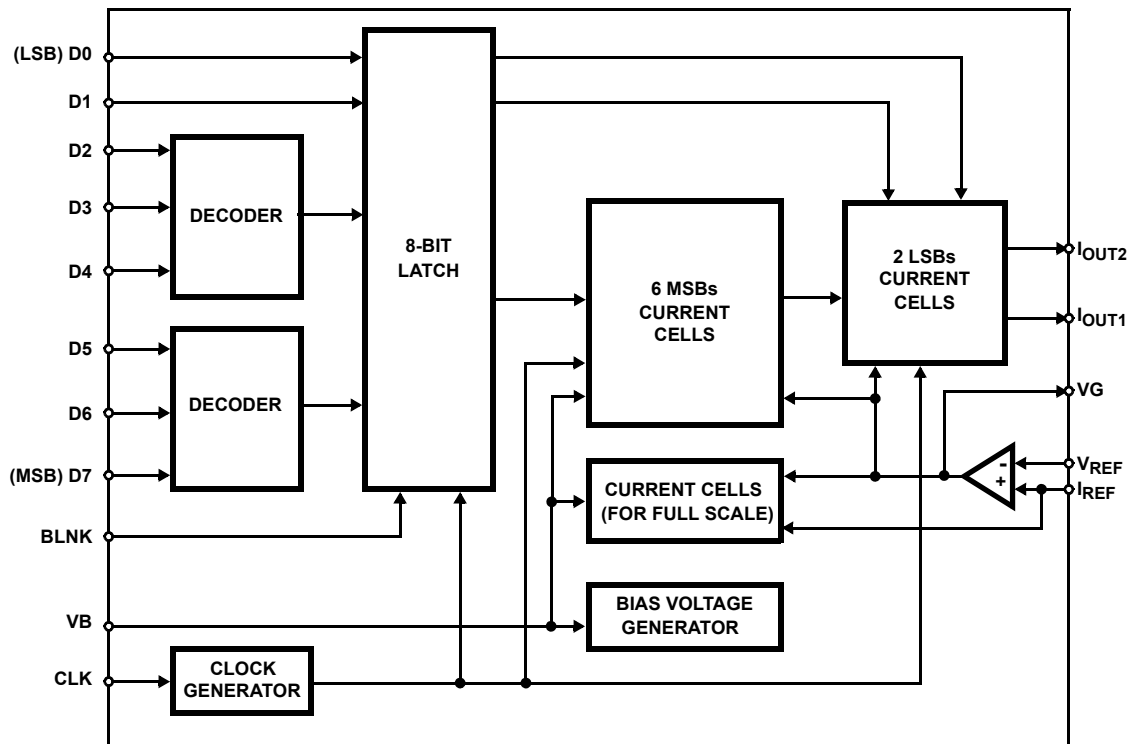

Absolute Maximum Ratings

Digital Supply Voltage DV_{DD} to DV_{SS}	+7.0V
Analog Supply Voltage AV_{DD} to AV_{SS}	+7.0V
Input Voltage	V_{DD} to V_{SS} V
Output Current	0mA to 15mA

Operating Conditions

Temperature Range	-40°C to 85°C
-------------------------	---------------

CAUTION: Stresses above those listed in "Absolute Maximum Ratings" may cause permanent damage to the device. This is a stress only rating and operation of the device at these or any other conditions above those indicated in the operational sections of this specification is not implied.

NOTE:

- θ_{JA} is measured with the component mounted on an evaluation PC board in free air.

Thermal Information

Thermal Resistance (Typical, Note 1)	θ_{JA} (°C/W)
SOIC Package	98
Maximum Junction Temperature, Plastic Package	150°C
Maximum Storage Temperature Range	-65°C to 150°C
Maximum Lead Temperature (Soldering 10s)	300°C (SOIC - Lead Tips Only)

Electrical Specifications $AV_{DD} = +4.75V$ to $+5.25V$, $DV_{DD} = +4.75$ to $+5.25V$, $V_{REF} = +2.0V$, $f_S = 40MHz$,
 CLK Pulse Width = 12.5ns, $T_A = 25^\circ C$ (Note 4)

PARAMETER	TEST CONDITIONS	MIN	TYP	MAX	UNITS
SYSTEM PERFORMANCE					
Resolution, n		-	8	-	Bits
Integral Linearity Error, INL	$f_S = 40MHz$ (End Point)	-0.5	-	1.3	LSB
Differential Linearity Error, DNL	$f_S = 40MHz$	-	-	± 0.25	LSB
Offset Error, V_{OS}	(Note 2)	-	-	1	mV
Full Scale Error, FSE (Adjustable to Zero)	(Note 2)	-	-	± 13	LSB
Full Scale Output Current, I_{FS}		-	10	15	mA
Full Scale Output Voltage, V_{FS}		1.9	2.0	2.1	V
Output Voltage Range, V_{FSR}		0.5	2.0	2.1	V
DYNAMIC CHARACTERISTICS					
Throughput Rate	See Figure 7	40.0	-	-	MHz
Glitch Energy, GE	$R_{OUT} = 75\Omega$	-	30	-	pV-s
Differential Gain, ΔA_V (Note 3)		-	1.2	-	%
Differential Phase, $\Delta\phi$ (Note 3)		-	0.5	-	Degree
REFERENCE INPUT					
Voltage Reference Input Range		0.5	-	2.0	V
Reference Input Resistance	(Note 3)	1.0	-	-	M Ω
DIGITAL INPUTS					
Input Logic High Voltage, V_{IH}	(Note 3)	3.0	-	-	V
Input Logic Low Voltage, V_{IL}	(Note 3)	-	-	1.5	V
Input Logic Current, I_{IL} , I_{IH}	(Note 3)	-	-	± 5.0	μA
Digital Input Capacitance, C_{IN}	(Note 3)	-	5.0	-	pF
TIMING CHARACTERISTICS					
Data Setup Time, t_{SU}	See Figure 1	5	-	-	ns
Data Hold Time, t_{HLD}	See Figure 1	10	-	-	ns

Electrical Specifications $AV_{DD} = +4.75V$ to $+5.25V$, $DV_{DD} = +4.75$ to $+5.25V$, $V_{REF} = +2.0V$, $f_S = 40MHz$,
 CLK Pulse Width = 12.5ns, $T_A = 25^{\circ}C$ (Note 4) **(Continued)**

PARAMETER	TEST CONDITIONS	MIN	TYP	MAX	UNITS
Propagation Delay Time, t_{PD}	See Figure 9	-	10	-	ns
Settling Time, t_{SET} (to $1/2$ LSB)	See Figure 1	-	10	15	ns
CLK Pulse Width, t_{PW1} , t_{PW2}	See Figure 1	12.5	-	-	ns
POWER SUPPLY CHARACTERISTICS					
IAV_{DD}	14.3MHz, at Color Bar Data Input	-	10.9	11.5	mA
IDV_{DD}	14.3MHz, at Color Bar Data Input	-	4.2	4.8	mA
Power Dissipation	200 Ω load at 2V _{P-P} Output	-	-	80	mW

NOTES:

2. Excludes error due to external reference drift.
3. Parameter guaranteed by design or characterization and not production tested.
4. Electrical specifications guaranteed only under the stated operating conditions.

Timing Diagram

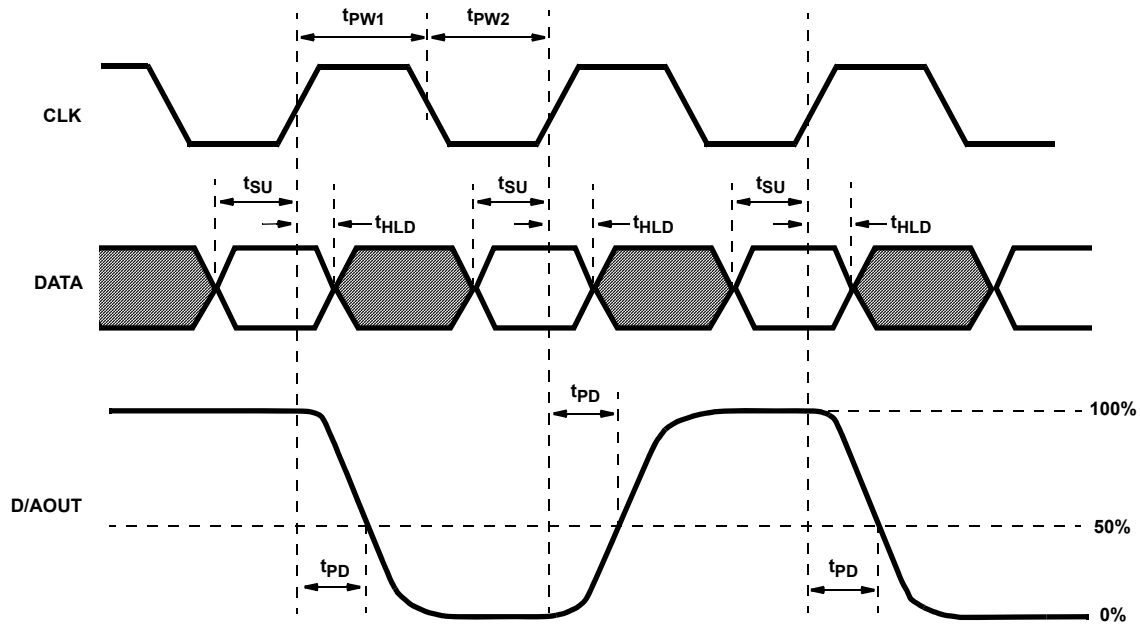

FIGURE 1.

Typical Performance Curves

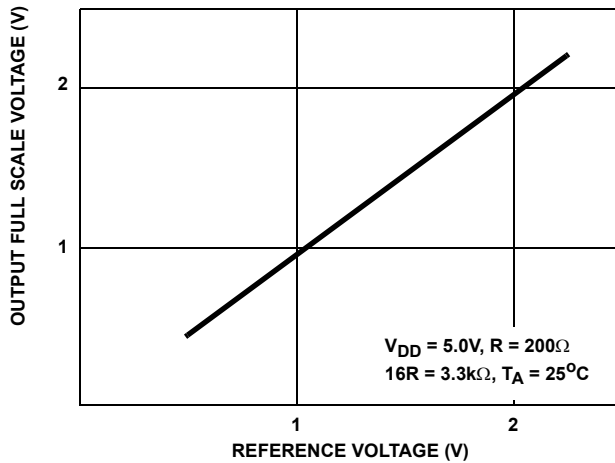

FIGURE 2. OUTPUT FULL SCALE VOLTAGE vs REFERENCE VOLTAGE

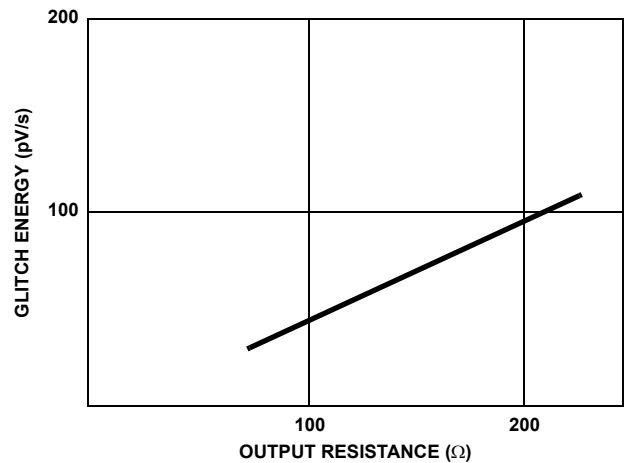

FIGURE 3. OUTPUT RESISTANCE vs GLITCH ENERGY

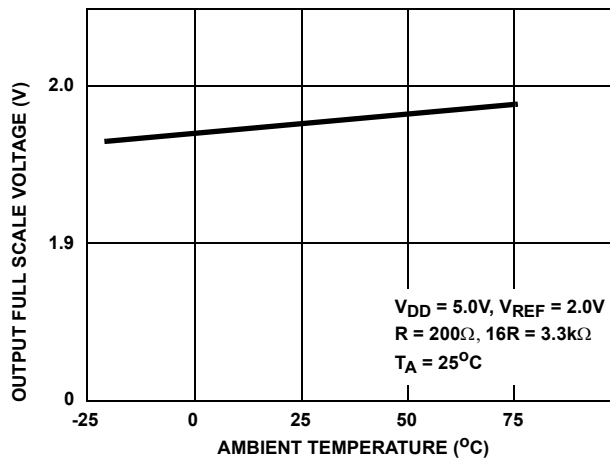

FIGURE 4. OUTPUT FULL SCALE VOLTAGE vs AMBIENT TEMPERATURE

Pin Descriptions

24 PIN SOIC	PIN NAME	PIN DESCRIPTION
1-8	D0(LSB) thru D7(MSB)	Digital Data Bit 0, the Least Significant Bit thru Digital Data Bit 7, the Most Significant Bit.
9	BLNK	Blanking Line, used to clear the internal data register to the zero condition when High, normal operation when Low.
10, 13	DV _{SS}	Digital Ground.
11	VB	Voltage Bias, connect a 0.1μF capacitor to DV _{SS} .
12	CLK	Data Clock Pin 100kHz to 40MHz.
14	AV _{SS}	Analog Ground.
15	I _{REF}	Current Reference, used to set the current range. Connect a resistor to AV _{SS} that is 16 times greater than the resistor on I _{OUT1} . (See Typical Applications Circuit).
16	V _{REF}	Input Reference Voltage used to set the output full scale range.
17	VG	Voltage Ground, connect a 0.1μF capacitor to AV _{DD} .
18, 19, 22	AV _{DD}	Analog Supply 4.75V to 7V.
20	I _{OUT1}	Current Output Pin.

Pin Descriptions (Continued)

24 PIN SOIC	PIN NAME	PIN DESCRIPTION
21	I _{OUT2}	Current Output pin used for a virtual ground connection. Usually connected to AV _{SS} .
23, 24	DV _{DD}	Digital Supply 4.75V to 7V.

Detailed Description

The HI1171 is an 8-bit, current out D/A converter. The DAC can convert at 40MHz and run on a single +5V supply. The architecture is an encoded, switched current cell arrangement.

Voltage Output Mode

The output current of the HI1171 can be converted into a voltage by connecting an external resistor to I_{OUT1}. To calculate the output resistor use the following equation:

$$R_{OUT} = V_{FS} / I_{FS}$$

where V_{FS} can range from +0.5V to +2.0V and I_{FS} can range from 0mA to 15mA.

In setting the output current the I_{REF} pin should have a resistor connected to it that is 16 times greater than the output resistor:

$$R_{REF} = 16 \times R_{OUT}$$

As the values of both R_{OUT} and R_{REF} increase, power consumption is decreased, but glitch energy and output settling time is increased.

Clock Phase Relationship

The internal latch is closed when the clock line is high. The latch can be cleared by the BLNK line. When BLNK is set (HIGH) the contents of the internal data latch will be cleared. When BLNK is low data is updated by the CLK.

Noise Reduction

To reduce power supply noise separate analog and digital power supplies should be used with 0.1µF ceramic capacitors placed as close to the body of the HI1171 as possible. The analog (AV_{SS}) and digital (DV_{SS}) ground returns should be connected together back at the power supply to ensure proper operation from power up.

Test Circuits

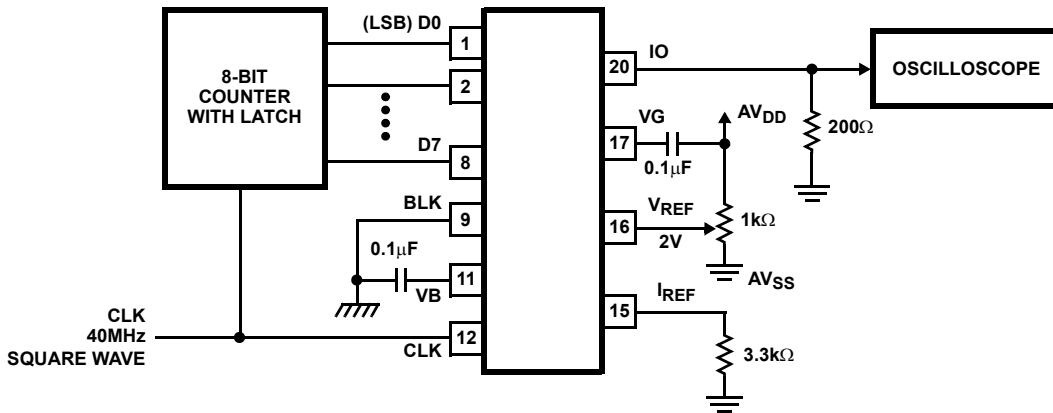

FIGURE 5. MAXIMUM CONVERSION SPEED TEST CIRCUIT

© Copyright Intersil Americas LLC 1997-2005. All Rights Reserved.
 All trademarks and registered trademarks are the property of their respective owners.

For additional products, see www.intersil.com/en/products.html

Intersil products are manufactured, assembled and tested utilizing ISO9001 quality systems as noted in the quality certifications found at www.intersil.com/en/support/qualandreliability.html

Intersil products are sold by description only. Intersil may modify the circuit design and/or specifications of products at any time without notice, provided that such modification does not, in Intersil's sole judgment, affect the form, fit or function of the product. Accordingly, the reader is cautioned to verify that datasheets are current before placing orders. Information furnished by Intersil is believed to be accurate and reliable. However, no responsibility is assumed by Intersil or its subsidiaries for its use; nor for any infringements of patents or other rights of third parties which may result from its use. No license is granted by implication or otherwise under any patent or patent rights of Intersil or its subsidiaries.

For information regarding Intersil Corporation and its products, see www.intersil.com

Test Circuits (Continued)

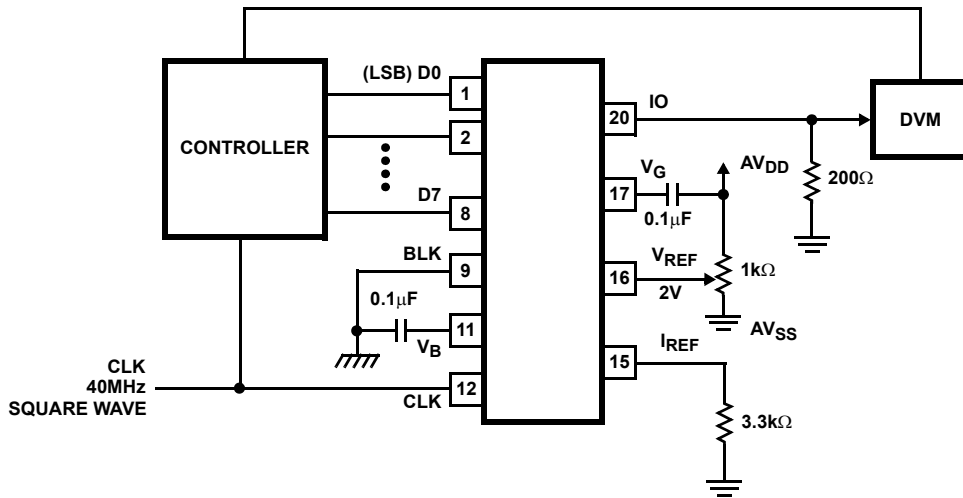

FIGURE 6. DC CHARACTERISTICS TEST CIRCUIT

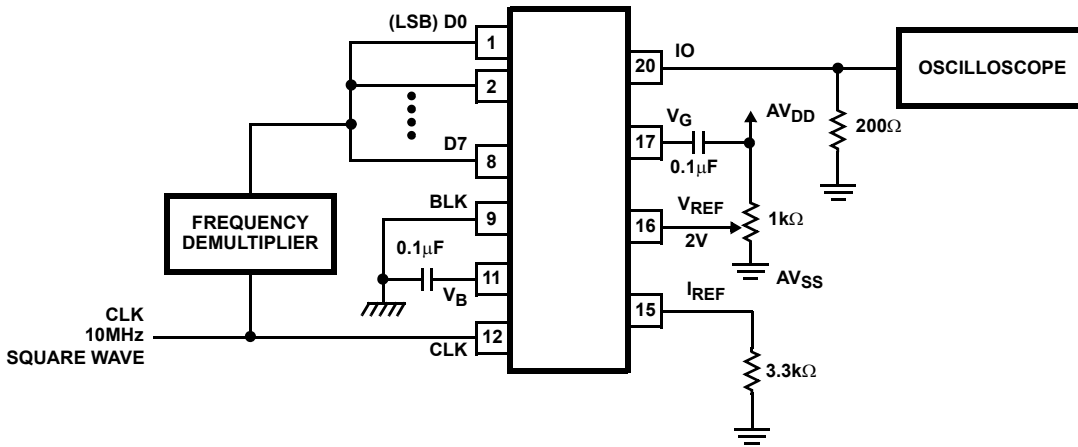

FIGURE 7. PROPAGATION DELAY TIME TEST CIRCUIT

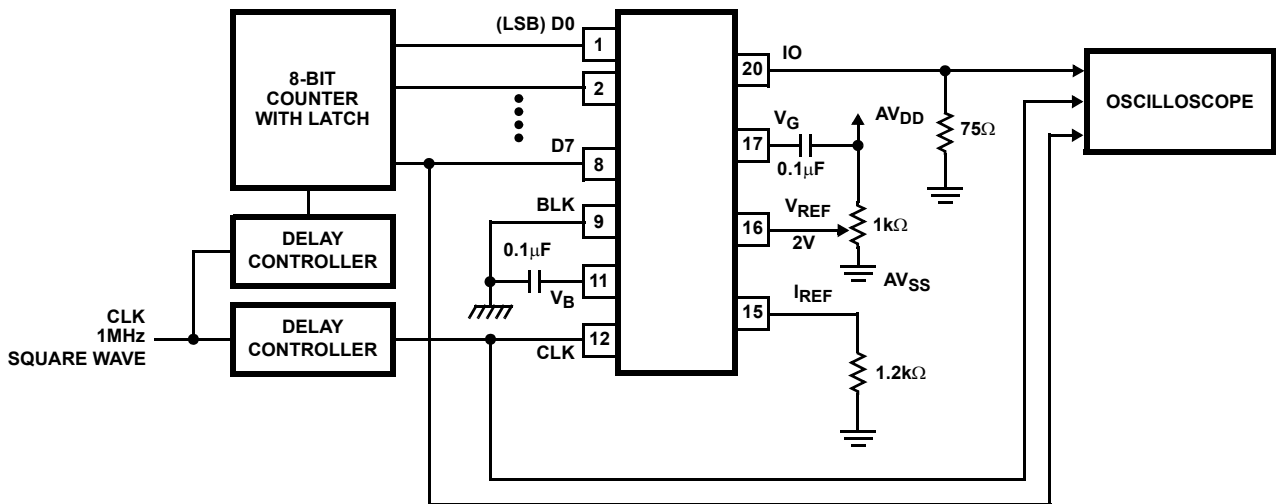

FIGURE 8. SET UP HOLD TIME AND GLITCH ENERGY TEST CIRCUIT

Looking for pricing, stock, or lifecycle information?

Click below to explore more details on WIN SOURCE:

 [View HI1171JCB-T on WIN SOURCE](#)

 [Intersil Information](#)

Optimize Your Supply Chain with WIN SOURCE Solutions

-  Global Sourcing Solution
-  Obsolete Management
-  Cost Control Management
-  Shortage Management
-  Alternative Solution
-  Excess Inventory Management