



THE DATASHEET OF STL35N6F3





STL35N6F3

N-channel 60 V, 0.019 Ω , 10 A STripFET™ III Power MOSFET in PowerFLAT™ 5x6 package

Datasheet — production data

Features

Order code	V _{DSS}	R _{DS(on)} max	I _D
STL35N6F3	60 V	< 0.022 Ω	10 A

- N-channel enhancement mode
- 100% avalanche rated
- Low gate charge
- Very low on-resistance

Applications

- Switching applications

Description

This device is an N-channel enhancement mode Power MOSFET produced using STMicroelectronics' STripFET™ III technology, which is specifically designed to minimize on-resistance and gate charge to provide superior switching performance.

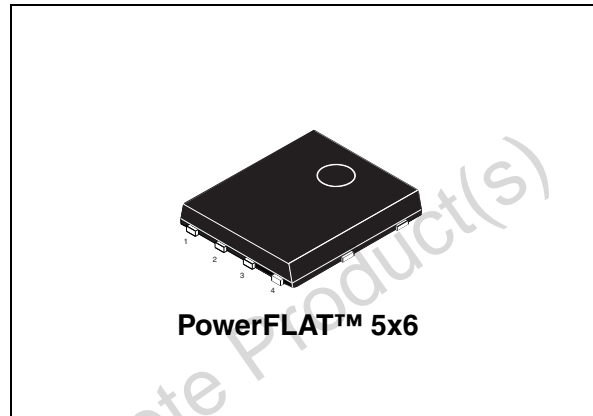

Figure 1. Internal schematic diagram

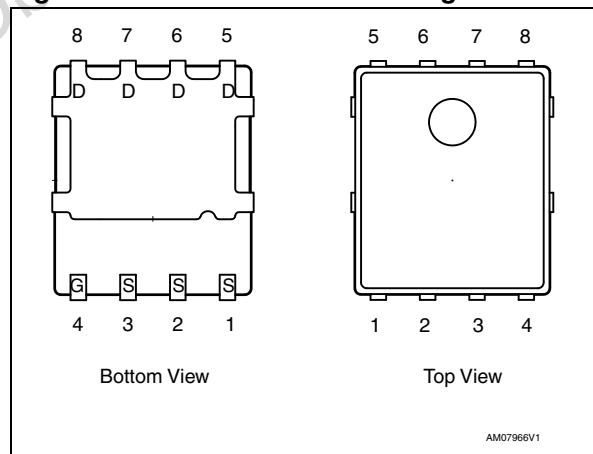

Table 1. Device summary

Order code	Marking	Package	Packaging
STL35N6F3	35N6F3	PowerFLAT™ 5x6	Tape and reel

Contents

1	Electrical ratings	3
2	Electrical characteristics	4
2.1	Electrical characteristics (curves)	6
3	Test circuits	8
4	Package mechanical data	9
5	Packaging mechanical data	14
6	Revision history	16

Obsolete Product(s) - Obsolete Product(s)



1 Electrical ratings

Table 2. Absolute maximum ratings

Symbol	Parameter	Value	Unit
V_{DS}	Drain-source voltage	60	V
V_{GS}	Gate-source voltage	± 20	V
$I_D^{(1)}$	Drain current (continuous) at $T_C = 25\text{ }^\circ\text{C}$	35	A
$I_D^{(1)}$	Drain current (continuous) at $T_C = 100\text{ }^\circ\text{C}$	25	A
$I_D^{(2)}$	Drain current (continuous) at $T_{pcb} = 25\text{ }^\circ\text{C}$	10	A
$I_D^{(2)}$	Drain current (continuous) at $T_{pcb}=100\text{ }^\circ\text{C}$	7	A
$I_{DM}^{(3)}$	Drain current (pulsed)	100	A
$P_{TOT}^{(1)}$	Total dissipation at $T_C = 25\text{ }^\circ\text{C}$	80	W
$P_{TOT}^{(2)}$	Total dissipation at $T_{pcb} = 25\text{ }^\circ\text{C}$	5	W
T_{stg}	Storage temperature	-55 to 175	$^\circ\text{C}$
T_j	Operating junction temperature		

1. The value is rated according to R_{thj-c}
2. The value is rated according to $R_{thj-pcb}$
3. Pulse width limited by safe operating area

Table 3. Thermal data

Symbol	Parameter	Value	Unit
$R_{thj-pcb}^{(1)}$	Thermal resistance junction-pcb max	31.3	$^\circ\text{C}/\text{W}$
$R_{thj-case}$	Thermal resistance junction-case max.	1.9	$^\circ\text{C}/\text{W}$

1. When mounted on FR-4 board of 1 inch², 2 oz Cu, $t < 10\text{ sec}$

Table 4. Avalanche characteristics

Symbol	Parameter	Max value	Unit
I_{AV}	Not-repetitive avalanche current	5	A
E_{AS}	Single pulse avalanche energy (starting $T_j = 25\text{ }^\circ\text{C}$, $I_D = I_{AV}$, $V_{DD} = 50\text{ V}$)	409	mJ

2 Electrical characteristics

($T_J = 25\text{ °C}$ unless otherwise specified)

Table 5. On/off states

Symbol	Parameter	Test conditions	Min.	Typ.	Max.	Unit
$V_{(BR)DSS}$	Drain-source breakdown voltage	$I_D = 250\ \mu\text{A}$, $V_{GS} = 0$	60			V
I_{DSS}	Zero gate voltage drain current ($V_{GS} = 0$)	$V_{DS} = 60\ \text{V}$, $V_{DS} = 60\ \text{V}$, $T_C = 125\text{ °C}$			1 10	μA μA
I_{GSS}	Gate body leakage current ($V_{DS} = 0$)	$V_{GS} = \pm 20\ \text{V}$			± 100	nA
$V_{GS(th)}$	Gate threshold voltage	$V_{DS} = V_{GS}$, $I_D = 250\ \mu\text{A}$	2		4	V
$R_{DS(on)}$	Static drain-source on-resistance	$V_{GS} = 10\ \text{V}$, $I_D = 10\ \text{A}$		0.019	0.022	Ω

Table 6. Dynamic

Symbol	Parameter	Test conditions	Min.	Typ.	Max.	Unit
C_{iss}	Input capacitance	$V_{DS} = 25\ \text{V}$, $f = 1\ \text{MHz}$, $V_{GS} = 0$	-	762	-	pF
C_{oss}	Output capacitance			173		
C_{rss}	Reverse transfer capacitance			16		
Q_g	Total gate charge	$V_{DD} = 30\ \text{V}$, $I_D = 10\ \text{A}$	-	13.6	-	nC
Q_{gs}	Gate-source charge	$V_{GS} = 10\ \text{V}$		5.0		
Q_{gd}	Gate-drain charge	(see Figure 13)		3.7		
R_g	Gate input resistance	$f = 1\ \text{MHz}$ open drain	-	3.2	-	Ω

Table 7. Switching times

Symbol	Parameter	Test conditions	Min.	Typ.	Max.	Unit
$t_{d(on)}$	Turn-on delay time	$V_{DD}=30\text{ V}$, $I_D=5\text{ A}$, $R_G=4.7\ \Omega$, $V_{GS}=10\text{ V}$ (see Figure 12)		9.7		ns
t_r	Rise time		-	2.9	-	ns
$t_{d(off)}$	Turn-off delay time				19	ns
t_f	Fall time				4	ns

Table 8. Source drain diode

Symbol	Parameter	Test conditions	Min.	Typ.	Max	Unit
I_{SD}	Source-drain current		-		10	A
$I_{SDM}^{(1)}$	Source-drain current (pulsed)		-		40	A
$V_{SD}^{(2)}$	Forward on voltage	$I_{SD}=10\text{ A}$, $V_{GS}=0$	-		1.5	V
t_{rr}	Reverse recovery time	$I_{SD}=10\text{ A}$, $di/dt=100\text{ A}/\mu\text{s}$, $V_{DD}=48\text{ V}$, $T_J=150\text{ }^\circ\text{C}$ (see Figure 14)		33		ns
Q_{rr}	Reverse recovery charge		-	51.2		nC
I_{RRM}	Reverse recovery current				3.1	A

1. Pulse width limited by safe operating area
2. Pulsed: pulse duration= 300 μs , duty cycle 1.5%

2.1 Electrical characteristics (curves)

Figure 2. Safe operating area

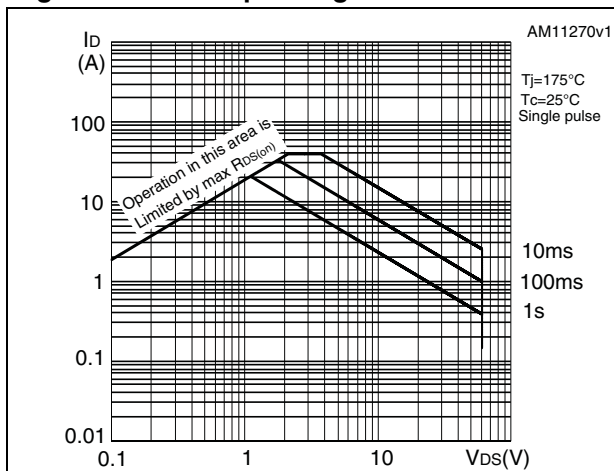

Figure 3. Thermal impedance

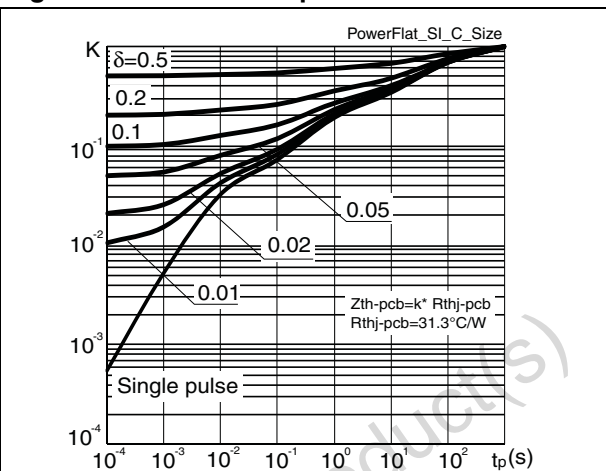

Figure 4. Output characteristics

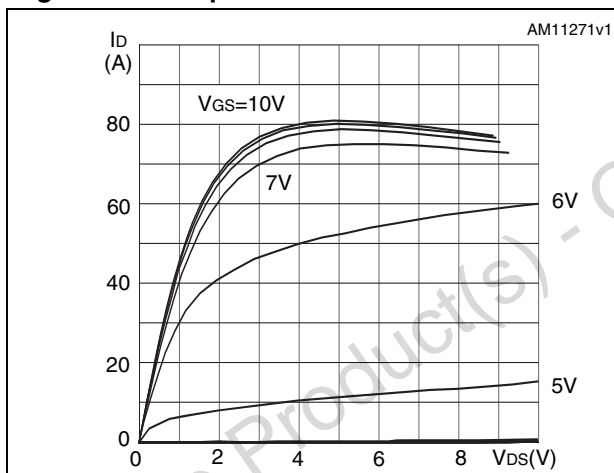

Figure 5. Transfer characteristics

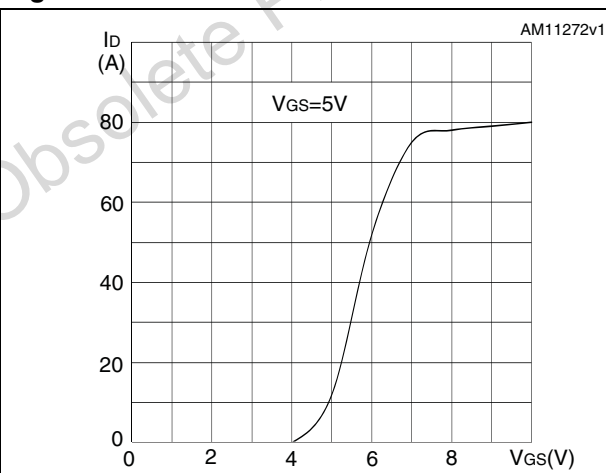

Figure 6. Normalized V_{DS} vs temperature

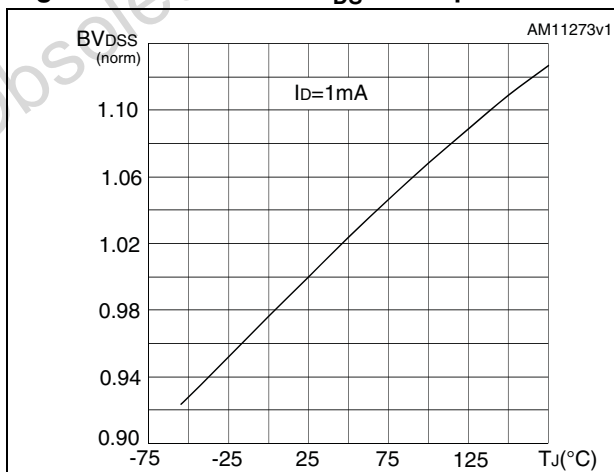

Figure 7. Static drain-source on-resistance

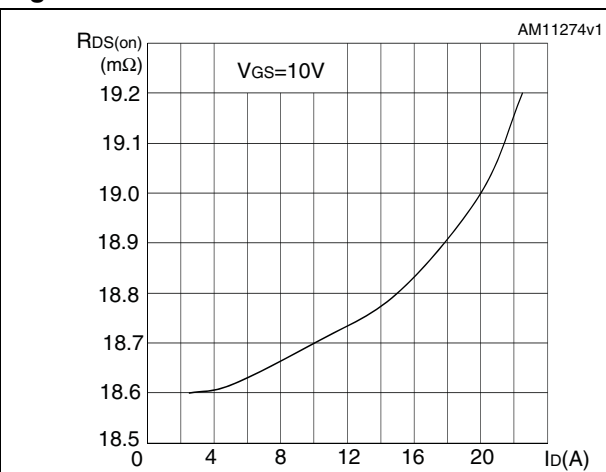

Figure 8. Gate charge vs gate-source voltage Figure 9. Capacitance variations

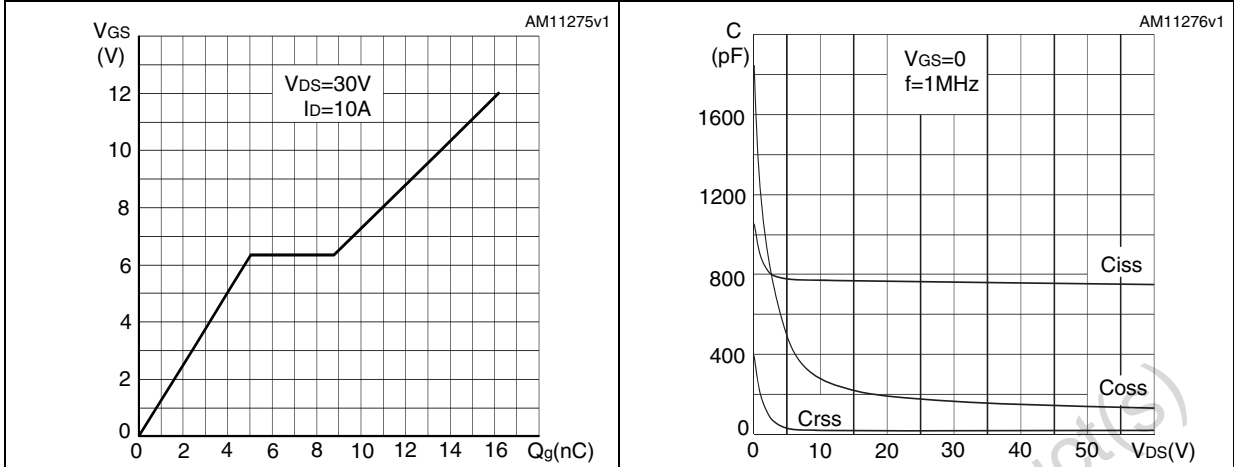
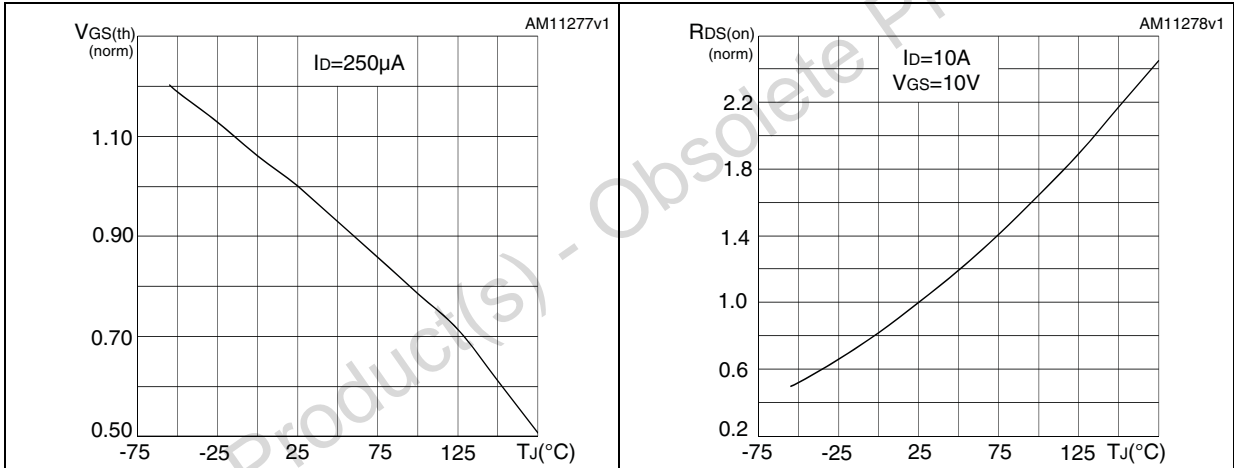
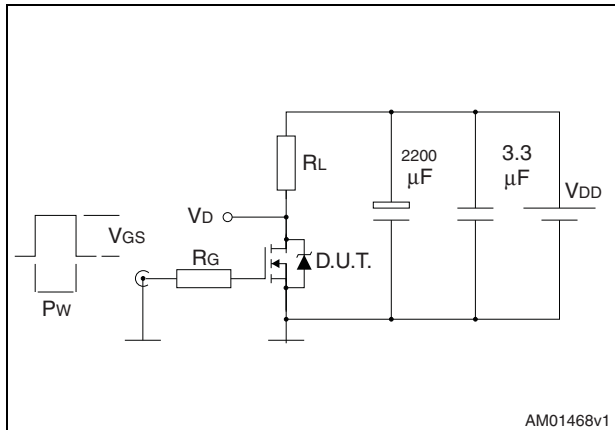

Figure 10. Normalized gate threshold voltage vs temperature Figure 11. Normalized on-resistance vs temperature



3 Test circuits

Figure 12. Switching times test circuit for resistive load



AM01468v1

Figure 13. Gate charge test circuit

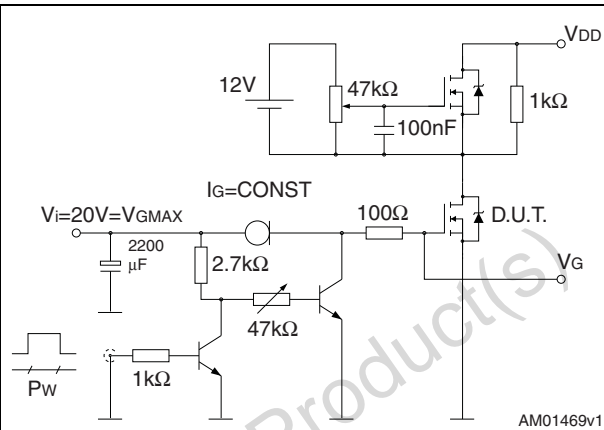

AM01469v1

Figure 14. Test circuit for inductive load switching and diode recovery times

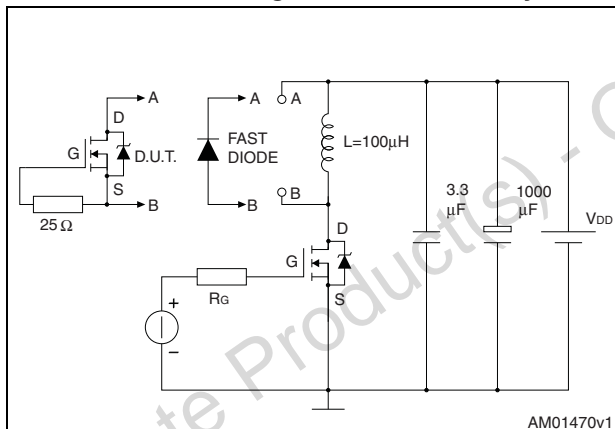

AM01470v1

Figure 15. Unclamped inductive load test circuit

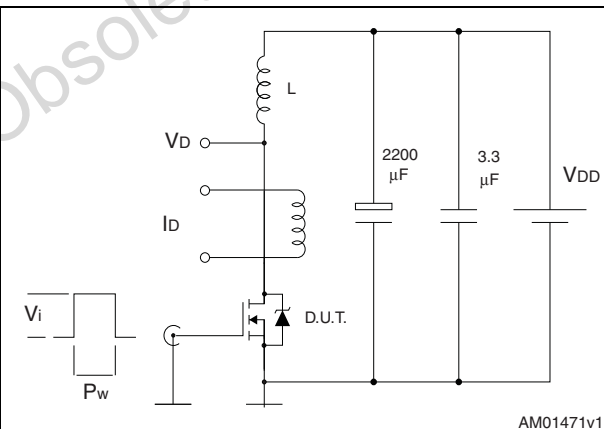

AM01471v1

Figure 16. Unclamped inductive waveform

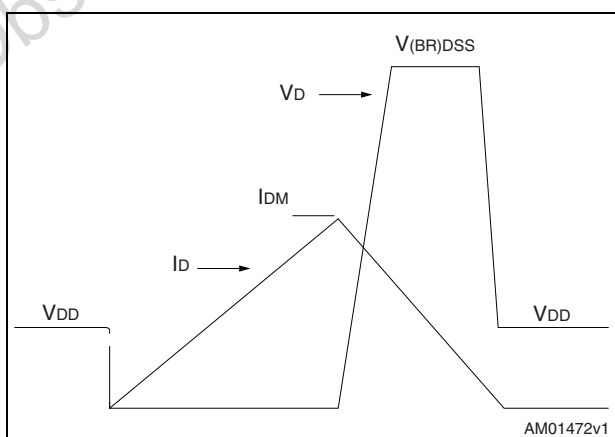

AM01472v1

Figure 17. Switching time waveform

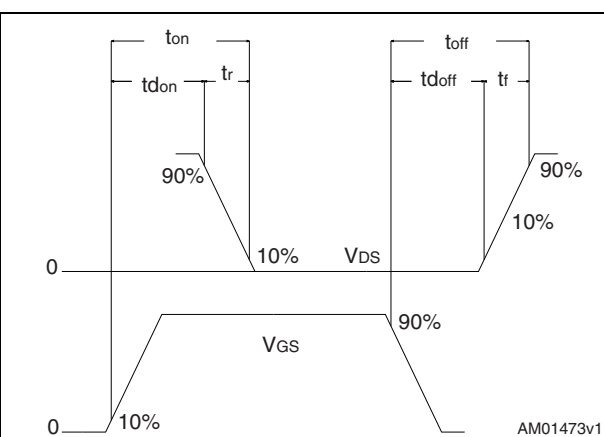

AM01473v1

4 Package mechanical data

In order to meet environmental requirements, ST offers these devices in different grades of ECOPACK® packages, depending on their level of environmental compliance. ECOPACK® specifications, grade definitions and product status are available at: www.st.com. ECOPACK is an ST trademark.

Table 9. PowerFLAT™ 5x6 type C-B mechanical data

Dim.	mm		
	Min.	Typ.	Max.
A	0.80	0.83	0.93
A1	0	0.02	0.05
A3		0.20	
b	0.35	0.40	0.47
D		5.00	
D1		4.75	
D2	4.15	4.20	4.25
E		6.00	
E1		5.75	
E2	3.43	3.48	3.53
E4	2.58	2.63	2.68
e		1.27	
L	0.70	0.80	0.90

Figure 18. PowerFLAT™ 5x6 type C-B drawing

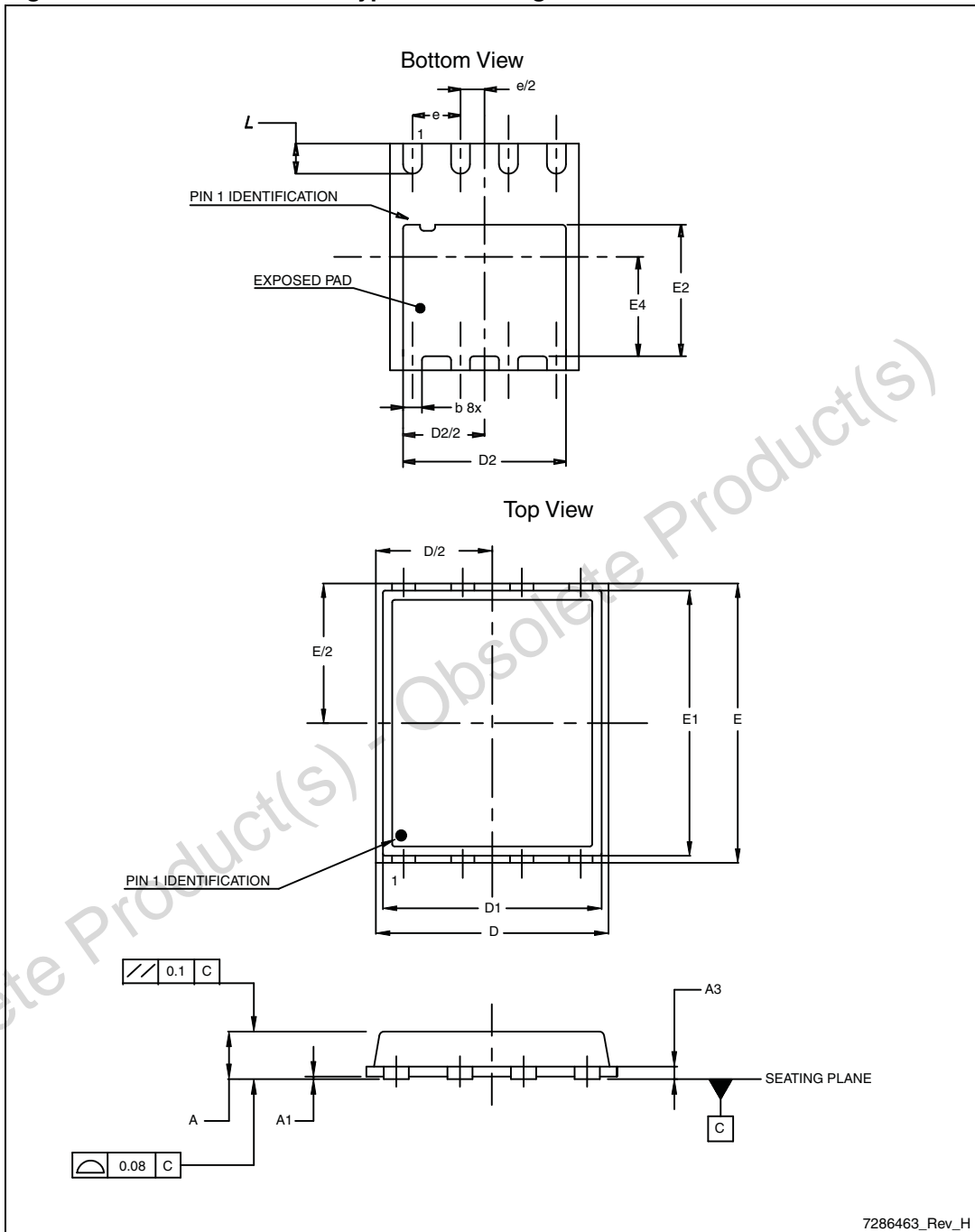

Table 10. PowerFLAT™ 5x6 type S-C mechanical data

Dim.	mm		
	Min.	Typ.	Max.
A	0.80		1.00
A1	0.02		0.05
A2		0.25	
b	0.30		0.50
D		5.20	
E		6.15	
D2	4.11		4.31
E2	3.50		3.70
e		1.27	
e1		0.65	
L	0.715		1.015
K	1.05		1.35

Figure 19. PowerFLAT™ 5x6 type S-C mechanical data

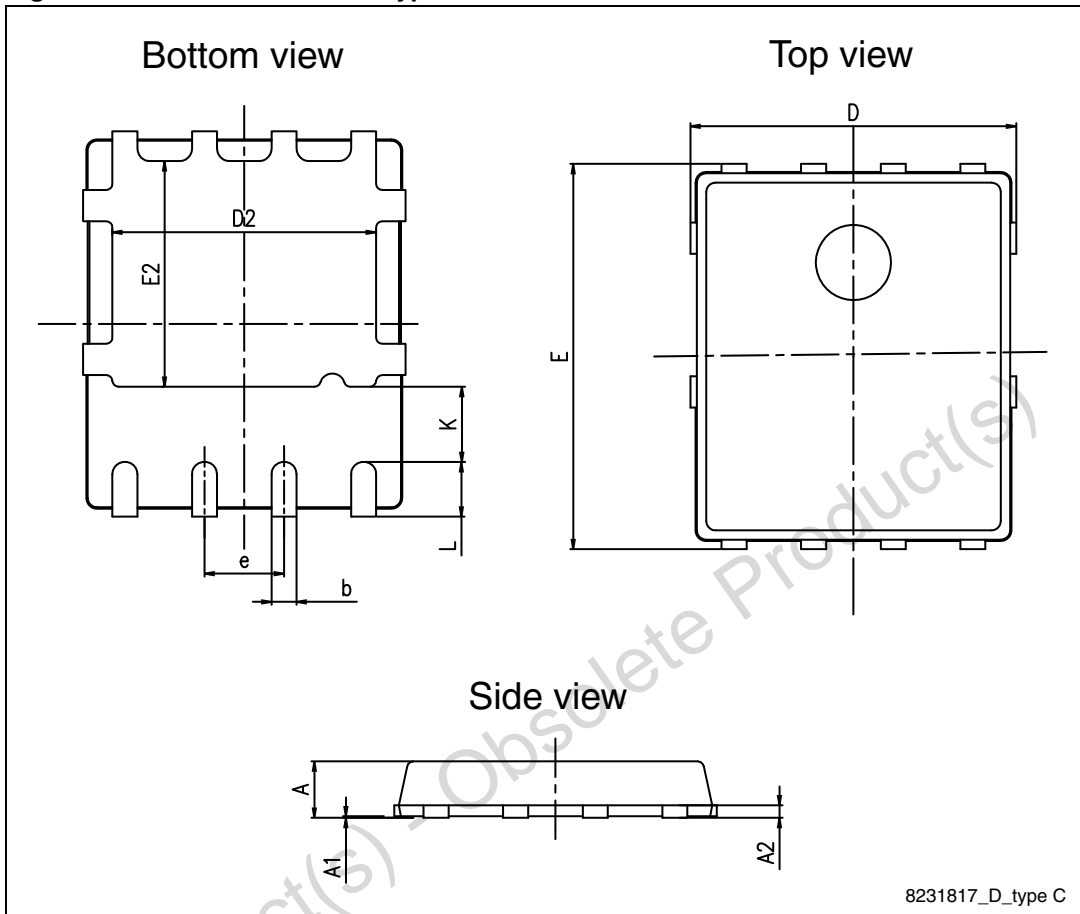
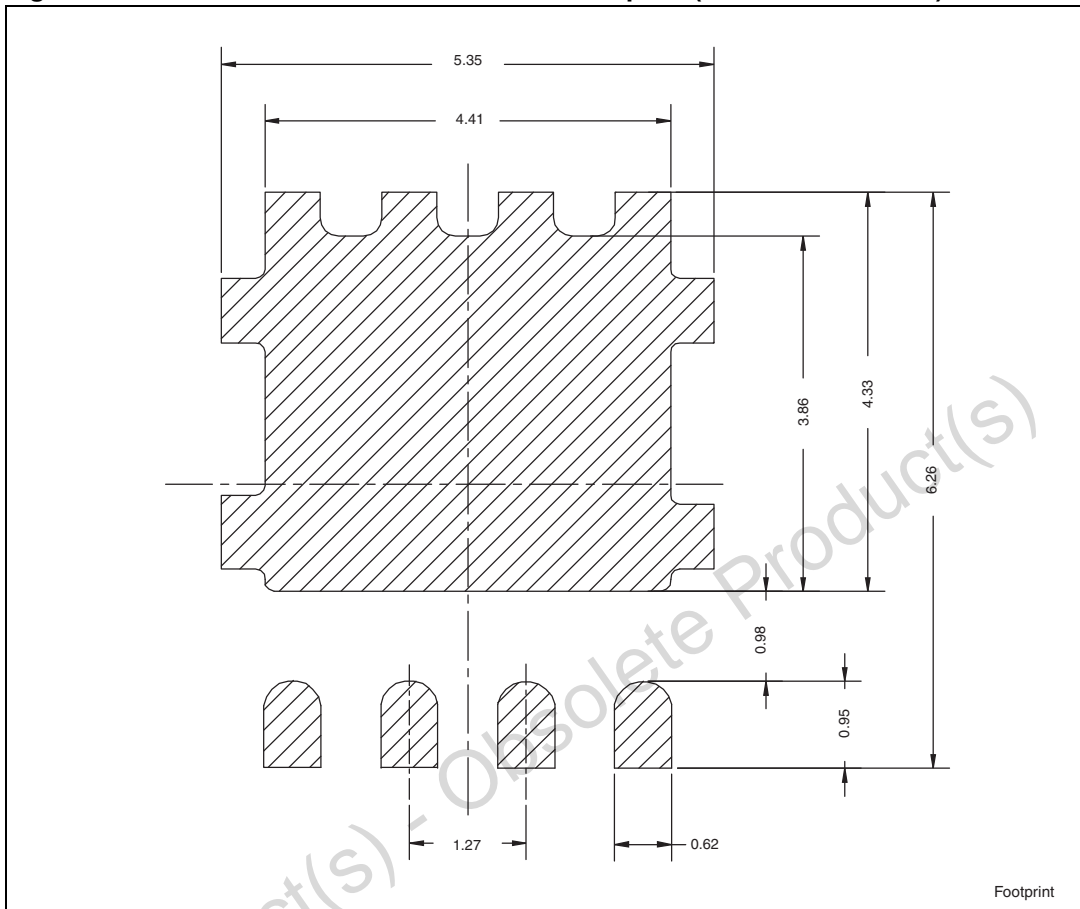

Figure 20. PowerFLAT™ 5x6 recommended footprint (dimensions in mm)



Obsolete Product(s)
Obsolete Product(s)

5 Packaging mechanical data

Figure 21. PowerFLAT™ 5x6 tape

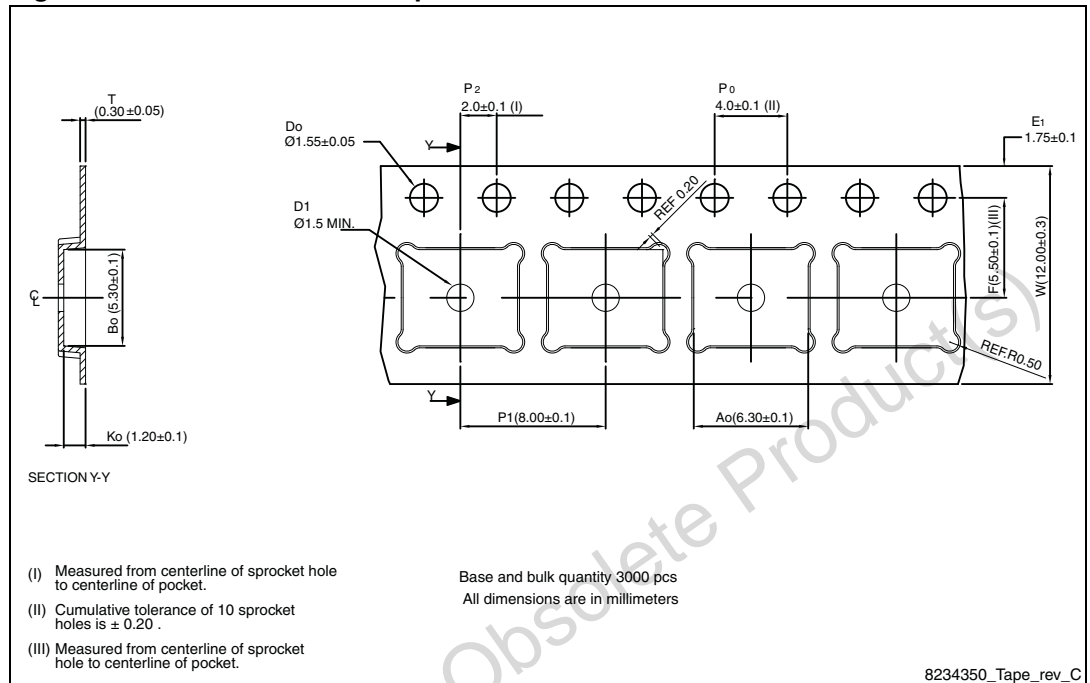

Figure 22. PowerFLAT™ 5x6 package orientation in carrier tape.

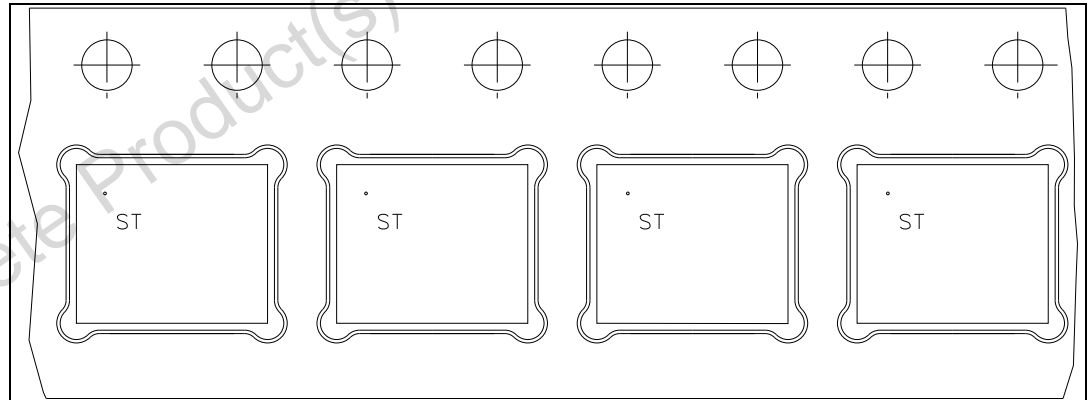
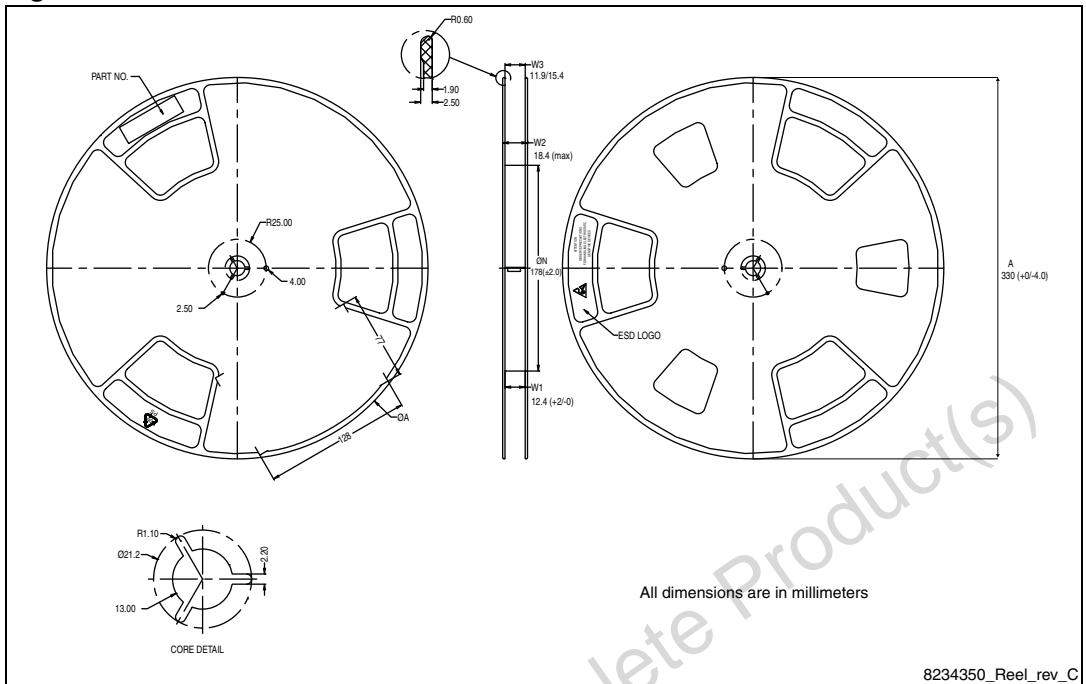

Figure 23. PowerFLAT™ 5x6 reel



6 Revision history

Table 11. Document revision history

Date	Revision	Changes
29-Oct-2009	1	First release.
15-Nov-2011	2	<i>Section 4: Package mechanical data</i> has been updated. Minor text changes. Document status promoted from preliminary data to datasheet.
27-Mar-2012	3	<i>Section 2.1: Electrical characteristics (curves)</i> has been inserted.
11-May-2012	4	<i>Figure 2: Safe operating area</i> and <i>Figure 3: Thermal impedance</i> have been changed.

Please Read Carefully:

Information in this document is provided solely in connection with ST products. STMicroelectronics NV and its subsidiaries ("ST") reserve the right to make changes, corrections, modifications or improvements, to this document, and the products and services described herein at any time, without notice.

All ST products are sold pursuant to ST's terms and conditions of sale.

Purchasers are solely responsible for the choice, selection and use of the ST products and services described herein, and ST assumes no liability whatsoever relating to the choice, selection or use of the ST products and services described herein.

No license, express or implied, by estoppel or otherwise, to any intellectual property rights is granted under this document. If any part of this document refers to any third party products or services it shall not be deemed a license grant by ST for the use of such third party products or services, or any intellectual property contained therein or considered as a warranty covering the use in any manner whatsoever of such third party products or services or any intellectual property contained therein.

UNLESS OTHERWISE SET FORTH IN ST'S TERMS AND CONDITIONS OF SALE ST DISCLAIMS ANY EXPRESS OR IMPLIED WARRANTY WITH RESPECT TO THE USE AND/OR SALE OF ST PRODUCTS INCLUDING WITHOUT LIMITATION IMPLIED WARRANTIES OF MERCHANTABILITY, FITNESS FOR A PARTICULAR PURPOSE (AND THEIR EQUIVALENTS UNDER THE LAWS OF ANY JURISDICTION), OR INFRINGEMENT OF ANY PATENT, COPYRIGHT OR OTHER INTELLECTUAL PROPERTY RIGHT.

UNLESS EXPRESSLY APPROVED IN WRITING BY TWO AUTHORIZED ST REPRESENTATIVES, ST PRODUCTS ARE NOT RECOMMENDED, AUTHORIZED OR WARRANTED FOR USE IN MILITARY, AIR CRAFT, SPACE, LIFE SAVING, OR LIFE SUSTAINING APPLICATIONS, NOR IN PRODUCTS OR SYSTEMS WHERE FAILURE OR MALFUNCTION MAY RESULT IN PERSONAL INJURY, DEATH, OR SEVERE PROPERTY OR ENVIRONMENTAL DAMAGE. ST PRODUCTS WHICH ARE NOT SPECIFIED AS "AUTOMOTIVE GRADE" MAY ONLY BE USED IN AUTOMOTIVE APPLICATIONS AT USER'S OWN RISK.

Resale of ST products with provisions different from the statements and/or technical features set forth in this document shall immediately void any warranty granted by ST for the ST product or service described herein and shall not create or extend in any manner whatsoever, any liability of ST.

ST and the ST logo are trademarks or registered trademarks of ST in various countries.

Information in this document supersedes and replaces all information previously supplied.

The ST logo is a registered trademark of STMicroelectronics. All other names are the property of their respective owners.

© 2012 STMicroelectronics - All rights reserved

STMicroelectronics group of companies

Australia - Belgium - Brazil - Canada - China - Czech Republic - Finland - France - Germany - Hong Kong - India - Israel - Italy - Japan - Malaysia - Malta - Morocco - Philippines - Singapore - Spain - Sweden - Switzerland - United Kingdom - United States of America

www.st.com



Looking for pricing, stock, or lifecycle information?

Click below to explore more details on WIN SOURCE:

- ⊖ [View STL35N6F3 on WIN SOURCE](#)
- ⊖ [STMicroelectronics Information](#)

Optimize Your Supply Chain with WIN SOURCE Solutions

- ✓ Global Sourcing Solution
- ✓ Obsolete Management
- ✓ Cost Control Management
- ✓ Shortage Management
- ✓ Alternative Solution
- ✓ Excess Inventory Management