

DATA SHEET

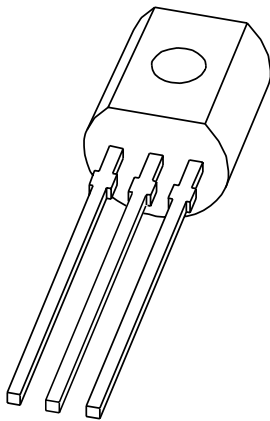

MPS3906 PNP switching transistor

Product specification
Supersedes data of 1999 Apr 12

2004 Oct 27

PNP switching transistor

MPS3906

FEATURES

- Low current (max. 100 mA)
- Low voltage (max. 40 V).

APPLICATIONS

- General purpose switching and amplification.

DESCRIPTION

PNP transistor in a plastic TO-92; SOT54 package.
NPN complement: MPS3904.

PINNING

PIN	DESCRIPTION
1	collector
2	base
3	emitter

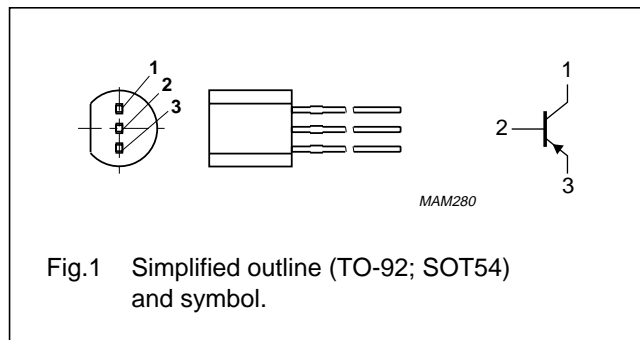

ORDERING INFORMATION

TYPE NUMBER	PACKAGE		
	NAME	DESCRIPTION	VERSION
MPS3906	SC-43A	plastic single-ended leaded (through hole) package; 3 leads	SOT54

LIMITING VALUES

In accordance with the Absolute Maximum Rating System (IEC 60134).

SYMBOL	PARAMETER	CONDITIONS	MIN.	MAX.	UNIT
V_{CBO}	collector-base voltage	open emitter	-	-40	V
V_{CEO}	collector-emitter voltage	open base	-	-40	V
V_{EBO}	emitter-base voltage	open collector	-	-5	V
I_C	collector current (DC)		-	-100	mA
I_{CM}	peak collector current		-	-200	mA
I_{BM}	peak base current		-	-200	mA
P_{tot}	total power dissipation	$T_{amb} \leq 25\text{ }^\circ\text{C}$	-	500	mW
T_{stg}	storage temperature		-65	+150	$^\circ\text{C}$
T_j	junction temperature		-	150	$^\circ\text{C}$
T_{amb}	ambient temperature		-65	+150	$^\circ\text{C}$

PNP switching transistor

MPS3906

THERMAL CHARACTERISTICS

SYMBOL	PARAMETER	CONDITIONS	VALUE	UNIT
$R_{th(j-a)}$	thermal resistance from junction to ambient	note 1	250	K/W

Note

1. Transistor mounted on an FR4 printed-circuit board.

CHARACTERISTICS

$T_{amb} = 25\text{ }^{\circ}\text{C}$ unless otherwise specified.

SYMBOL	PARAMETER	CONDITIONS	MIN.	MAX.	UNIT
I_{CBO}	collector-base cut-off current	$V_{CB} = -30\text{ V}$; $I_E = 0\text{ A}$	–	–50	nA
I_{EBO}	emitter-base cut-off current	$V_{EB} = -5\text{ V}$; $I_E = 0\text{ A}$	–	–50	nA
h_{FE}	DC current gain	$V_{CE} = -1\text{ V}$; note 1 $I_C = -0.1\text{ mA}$ $I_C = -1\text{ mA}$ $I_C = -10\text{ mA}$ $I_C = -50\text{ mA}$ $I_C = -100\text{ mA}$	60 80 100 60 30	– – 300 – –	
V_{CEsat}	collector-emitter saturation voltage	$I_C = -10\text{ mA}$; $I_B = -1\text{ mA}$; note 1	–	–250	mV
		$I_C = -50\text{ mA}$; $I_B = -5\text{ mA}$; note 1	–	–400	mV
V_{BEsat}	base-emitter saturation voltage	$I_C = -10\text{ mA}$; $I_B = -1\text{ mA}$; note 1	–650	–850	mV
		$I_C = -50\text{ mA}$; $I_B = -5\text{ mA}$; note 1	–	–950	mV
C_c	collector capacitance	$V_{CB} = -5\text{ V}$; $I_E = i_e = 0\text{ A}$; $f = 100\text{ kHz}$ to 1 MHz	–	5	pF
C_e	emitter capacitance	$V_{EB} = -0.5\text{ V}$; $I_C = i_c = 0\text{ A}$; $f = 100\text{ kHz}$ to 1 MHz	–	15	pF
f_T	transition frequency	$V_{CE} = -20\text{ V}$; $I_C = -10\text{ mA}$; $f = 100\text{ MHz}$	150	–	MHz
F	noise figure	$V_{CE} = -5\text{ V}$; $I_C = -100\text{ }\mu\text{A}$; $R_S = 1\text{ k}\Omega$; $f = 10\text{ Hz}$ to 15.7 kHz	–	4	dB

Switching times (between 10 % and 90 % levels); (see Fig.2)

t_{on}	turn-on time	$I_{Bon} = -10\text{ mA}$; $I_{Boff} = -1\text{ mA}$; $I_{Boff} = 1\text{ mA}$; $V_{CC} = -3\text{ V}$; $V_{BB} = 1.9\text{ V}$	–	100	ns
t_d	delay time		–	50	ns
t_r	rise time		–	50	ns
t_{off}	turn-off time		–	700	ns
t_s	storage time		–	600	ns
t_f	fall time		–	100	ns

Note

1. Pulse test: $t_p = 300\text{ }\mu\text{s}$; $\delta = 0.02$.

PNP switching transistor

MPS3906

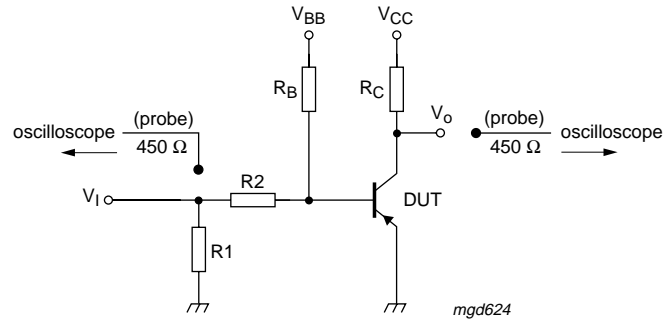

$V_i = -5\text{ V}$; $t_p \geq 4\ \mu\text{s}$; $t_r = t_f \leq 3\ \text{ns}$.
 $R_1 = 56\ \Omega$; $R_2 = 2.5\ \text{k}\Omega$; $R_B = 3.9\ \text{k}\Omega$; $R_C = 270\ \Omega$.
 Oscilloscope: input impedance $Z_i = 50\ \Omega$.

Fig.2 Test circuit for switching times.

PNP switching transistor

MPS3906

PACKAGE OUTLINE

Plastic single-ended leaded (through hole) package; 3 leads

SOT54

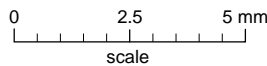
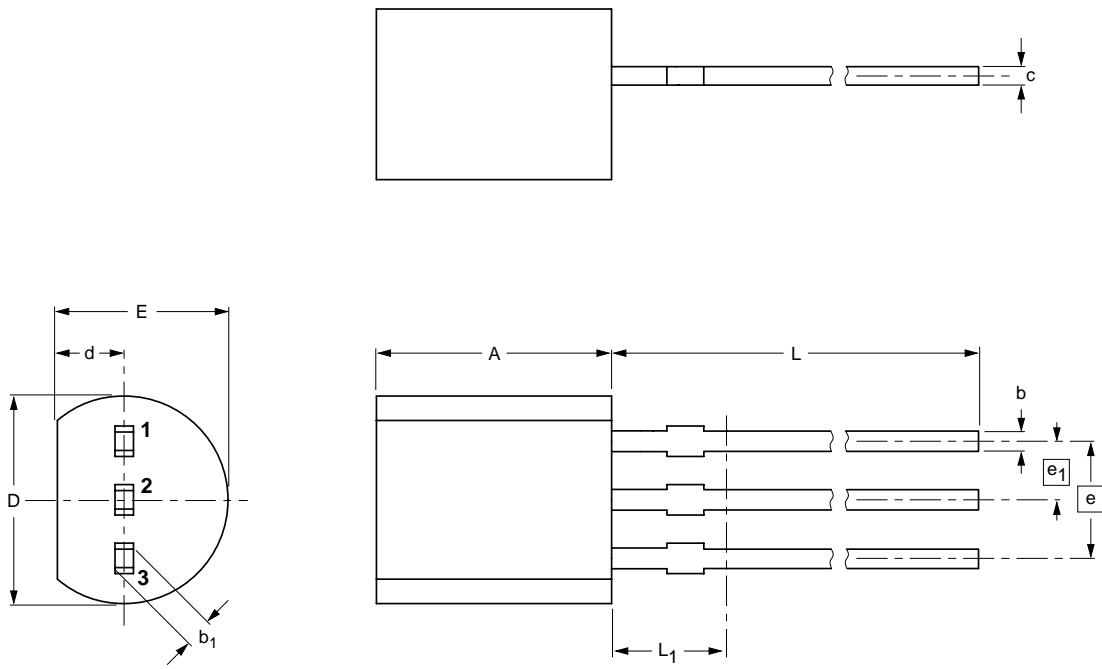

DIMENSIONS (mm are the original dimensions)

UNIT	A	b	b ₁	c	D	d	E	e	e ₁	L	L ₁ ⁽¹⁾ max.
mm	5.2 5.0	0.48 0.40	0.66 0.55	0.45 0.38	4.8 4.4	1.7 1.4	4.2 3.6	2.54	1.27	14.5 12.7	2.5

Note

1. Terminal dimensions within this zone are uncontrolled to allow for flow of plastic and terminal irregularities.

OUTLINE VERSION	REFERENCES			EUROPEAN PROJECTION	ISSUE DATE
	IEC	JEDEC	JEITA		
SOT54		TO-92	SC-43A		-97-02-28 04-06-28

PNP switching transistor

MPS3906

DATA SHEET STATUS

LEVEL	DATA SHEET STATUS ⁽¹⁾	PRODUCT STATUS ⁽²⁾⁽³⁾	DEFINITION
I	Objective data	Development	This data sheet contains data from the objective specification for product development. Philips Semiconductors reserves the right to change the specification in any manner without notice.
II	Preliminary data	Qualification	This data sheet contains data from the preliminary specification. Supplementary data will be published at a later date. Philips Semiconductors reserves the right to change the specification without notice, in order to improve the design and supply the best possible product.
III	Product data	Production	This data sheet contains data from the product specification. Philips Semiconductors reserves the right to make changes at any time in order to improve the design, manufacturing and supply. Relevant changes will be communicated via a Customer Product/Process Change Notification (CPCN).

Notes

1. Please consult the most recently issued data sheet before initiating or completing a design.
2. The product status of the device(s) described in this data sheet may have changed since this data sheet was published. The latest information is available on the Internet at URL <http://www.semiconductors.philips.com>.
3. For data sheets describing multiple type numbers, the highest-level product status determines the data sheet status.

DEFINITIONS

Short-form specification — The data in a short-form specification is extracted from a full data sheet with the same type number and title. For detailed information see the relevant data sheet or data handbook.

Limiting values definition — Limiting values given are in accordance with the Absolute Maximum Rating System (IEC 60134). Stress above one or more of the limiting values may cause permanent damage to the device. These are stress ratings only and operation of the device at these or at any other conditions above those given in the Characteristics sections of the specification is not implied. Exposure to limiting values for extended periods may affect device reliability.

Application information — Applications that are described herein for any of these products are for illustrative purposes only. Philips Semiconductors make no representation or warranty that such applications will be suitable for the specified use without further testing or modification.

DISCLAIMERS

Life support applications — These products are not designed for use in life support appliances, devices, or systems where malfunction of these products can reasonably be expected to result in personal injury. Philips Semiconductors customers using or selling these products for use in such applications do so at their own risk and agree to fully indemnify Philips Semiconductors for any damages resulting from such application.

Right to make changes — Philips Semiconductors reserves the right to make changes in the products - including circuits, standard cells, and/or software - described or contained herein in order to improve design and/or performance. When the product is in full production (status 'Production'), relevant changes will be communicated via a Customer Product/Process Change Notification (CPCN). Philips Semiconductors assumes no responsibility or liability for the use of any of these products, conveys no license or title under any patent, copyright, or mask work right to these products, and makes no representations or warranties that these products are free from patent, copyright, or mask work right infringement, unless otherwise specified.

Philips Semiconductors – a worldwide company

Contact information

For additional information please visit <http://www.semiconductors.philips.com>. Fax: +31 40 27 24825

For sales offices addresses send e-mail to: sales.addresses@www.semiconductors.philips.com.

© Koninklijke Philips Electronics N.V. 2004

SCA76

All rights are reserved. Reproduction in whole or in part is prohibited without the prior written consent of the copyright owner.

The information presented in this document does not form part of any quotation or contract, is believed to be accurate and reliable and may be changed without notice. No liability will be accepted by the publisher for any consequence of its use. Publication thereof does not convey nor imply any license under patent- or other industrial or intellectual property rights.

Printed in The Netherlands

R75/04/pp7

Date of release: 2004 Oct 27

Document order number: 9397 750 13608

Let's make things better.

**Philips
Semiconductors**



PHILIPS

Looking for pricing, stock, or lifecycle information?

Click below to explore more details on WIN SOURCE:

- ⊖ [View MPS3906,126 on WIN SOURCE](#)
- ⊖ [NXP / Nexperia Information](#)

Optimize Your Supply Chain with WIN SOURCE Solutions

- ✓ Global Sourcing Solution
- ✓ Obsolete Management
- ✓ Cost Control Management
- ✓ Shortage Management
- ✓ Alternative Solution
- ✓ Excess Inventory Management