

MS2267

RF & MICROWAVE TRANSISTORS AVIONICS APPLICATIONS

Features

- 960 – 1215MHz
- 50 VOLTS
- 5:1 VSWR CAPABILITY @ RATED CONDITIONS
- INPUT/OUTPUT MATCHING
- $P_{OUT} = 250$ WATTS
- $G_P = 8.0$ dB MINIMUM
- COMMON BASE CONFIGURATION

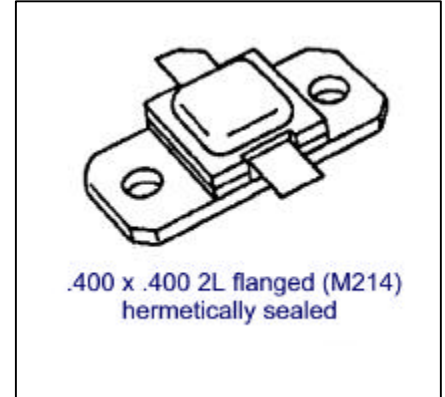

DESCRIPTION:

The MS2267 is a high power Class C NPN transistor specifically designed for TACAN/DME applications.

This device is capable of operation under moderate pulse width and duty cycles. Low thermal resistance and computerized automatic wire bonding techniques ensure high reliability and product consistency.

The MS2267 utilizes an emitter ballasted die geometry capable of operating into a 5:1 VSWR @ 1.0 dB overdrive.

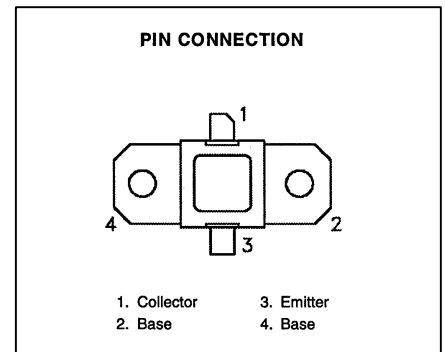

ABSOLUTE MAXIMUM RATINGS (T_{case} = 25°C)

Symbol	Parameter	Value	Unit
P_{DISS}	Power Dissipation* (T _C ≤ 90°C)	575	W
I_C	Device Current*	20	A
V_{CC}	Collector-Supply Voltage*	50	V
T_J	Junction Temperature (Pulsed RF Operation)	250	°C
T_{STG}	Storage Temperature	-65 to +200	°C

Thermal Data

$R_{TH(J-C)}$	Junction-case Thermal Resistance* ⁽¹⁾	0.28	°C/W
---------------	--	------	------

* Applies only to rated RF amplifier operation

⁽¹⁾ Infra-red scan of hot spot junction temperature at rated RF operating conditions

ELECTRICAL SPECIFICATIONS (T_{case} = 25°C)
STATIC

Symbol	Test Conditions		Value			Unit
			Min.	Typ.	Max.	
BV_{CBO}	I_C = 35mA	I_E = 0 mA	65	---	---	V
BV_{EBO}	I_E = 15mA	I_C = 0 mA	4.0	---	---	V
BV_{CES}	I_C = 25mA	I_B = 0 mA	60	---	---	V
I_{CES}	V_{BE} = 0 V	V_{CE} = 50V	---	---	20	mA
h_{FE}	V_{CE} = 5V	I_C = 1A	10	---	---	---

DYNAMIC

Symbol	Test Conditions			Value			Unit
				Min.	Typ.	Max.	
P_{OUT}	f = 960 - 1215MHz	P_{IN} = 40W	V_{CC} = 50V	250	295	---	W
η_c	f = 960 - 1215MHz	P_{IN} = 40W	V_{CC} = 50V	38	44	---	%
G_p	f = 960 - 1215MHz	P_{IN} = 40W	V_{CC} = 50V	8.0	8.7	---	dB

Conditions: Pulse width = 20 μS Duty Cycle = 5% T_C = 25°C

IMPEDANCE DATA

FREQ	Z _{IN} (Ω)	Z _{CL} (Ω)
960 MHz	1.0 + j3.5	1.9 – j1.8
1090MHz	4.0 + j3.5	1.6 – j0.9
1215MHz	2.2 + j2.2	1.4 – j1.1

P_{IN} = 40W
V_{CC} = 50V

TYPICAL PERFORMANCE

**TYPICAL BROADBAND
POWER AMPLIFIER**

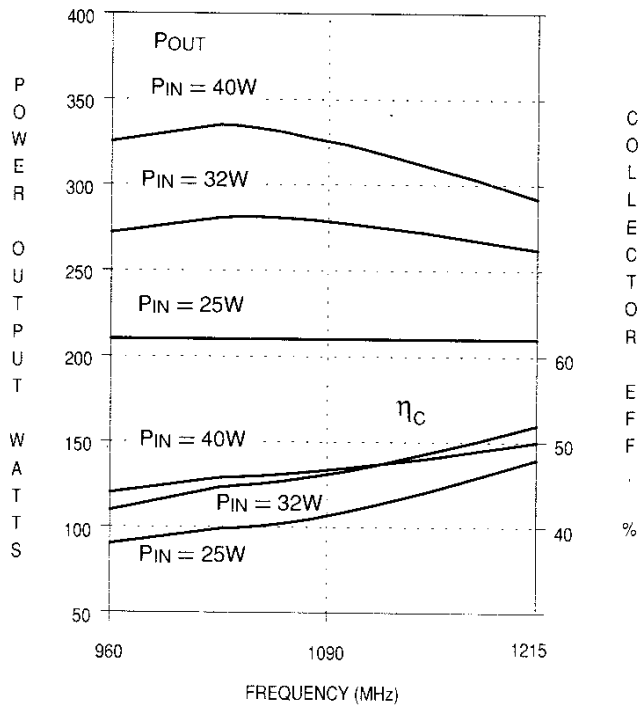

INPUT VSWR vs FREQUENCY

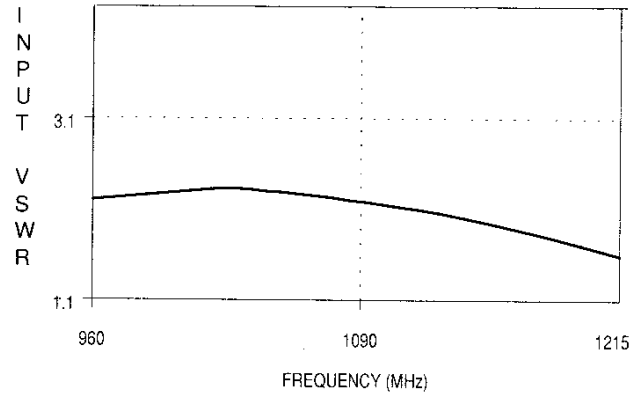

TYPICAL PERFORMANCE (CONTINUED)

**TYPICAL POWER OUTPUT &
COLLECTOR EFFICIENCY vs
COLLECTOR VOLTAGE**

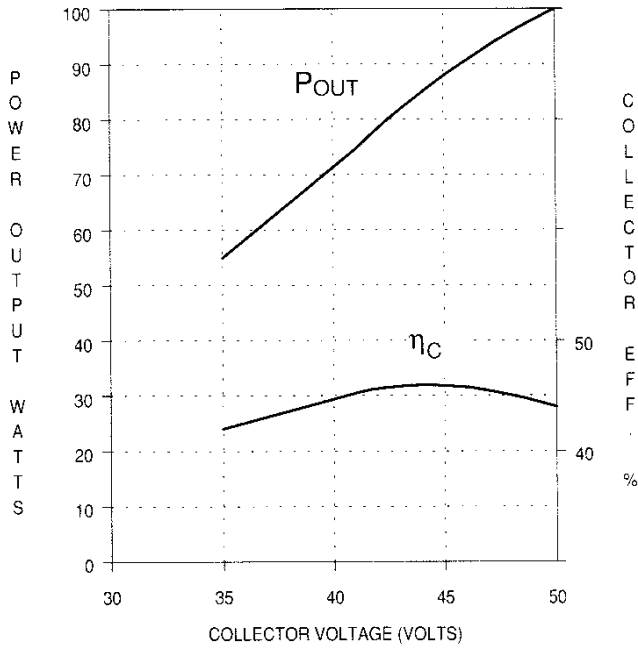

TEST CIRCUIT

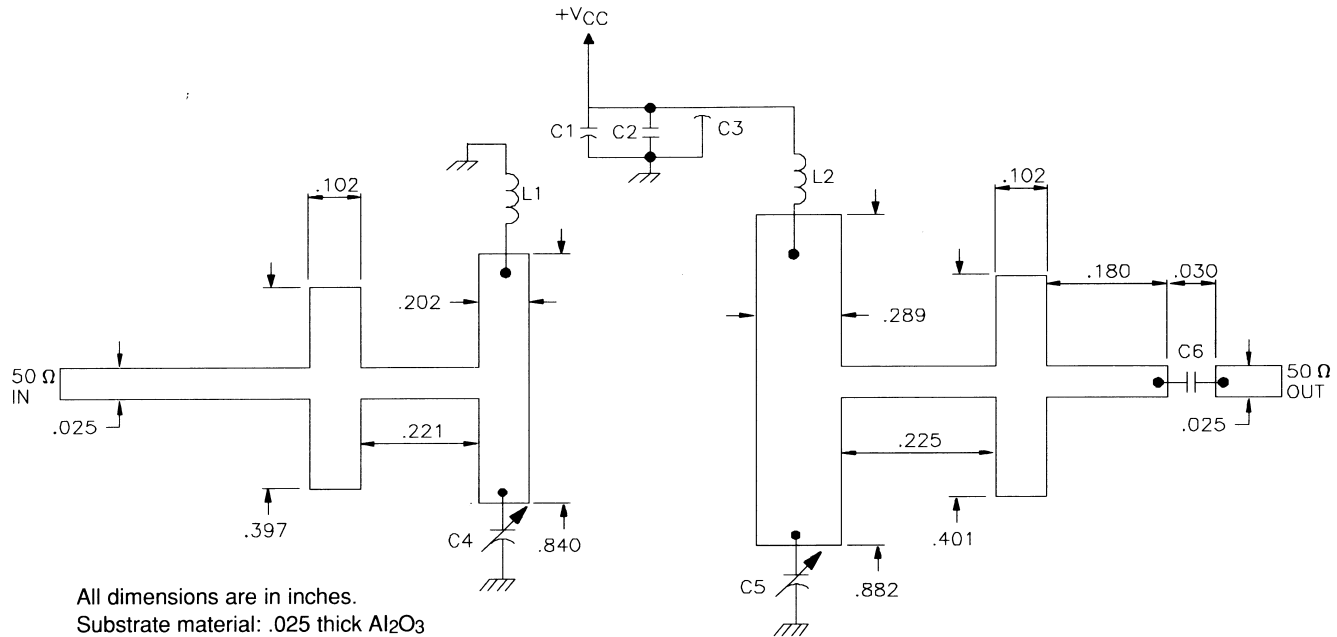

All dimensions are in inches.
Substrate material: .025 thick Al₂O₃

- C1 : 100 μF Electrolytic Capacitor, 63V
- C2 : .1 μF Ceramic Capacitor
- C3 : Feedthru Bypass SCI 712-022
- C4 : Johanson 7475 Gigatrim .6 — 4.5 pF

- C5 : Johanson 7475 Gigatrim .6 — 4.5 pF
- C6 : D.C. Block 100 pF
- L1 : #26 Wire, 4 Turn .062 I.D.
- L2 : #26 Wire, 4 Turn .062 I.D.

PACKAGE MECHANICAL DATA

PACKAGE STYLE M214

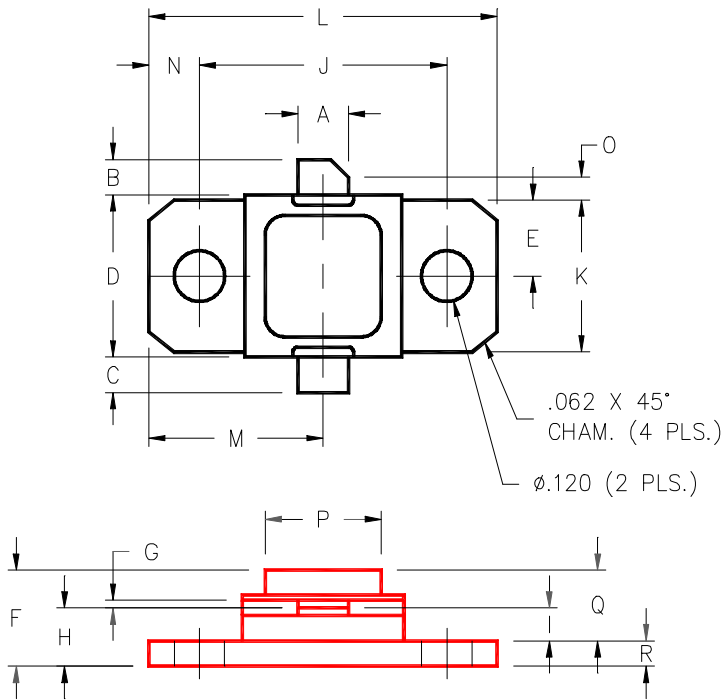

	MINIMUM INCHES/MM	MAXIMUM INCHES/MM		MINIMUM INCHES/MM	MAXIMUM INCHES/MM
A	.140/3,56		J	.650/16,51	
B	.110/2,80		K	.386/9,80	
C	.110/2,80		L	.900/22,86	
D	.395/10,03	.407/10,34	M	.450/11,43	
E	.193/4,90		N	.125/3,18	
F		.230/5,84	O	.050/1,27	
G	.003/0,08	.006/0,15	P	.405/10,29	
H	.118/3,00	.131/3,33	Q	.170/4,32	
I	.063/1,60		R	.062/1,58	

Looking for pricing, stock, or lifecycle information?

Click below to explore more details on WIN SOURCE:

- ⊖ [View MS2267 on WIN SOURCE](#)
- ⊖ [Microsemi Corporation](#) Information

Optimize Your Supply Chain with WIN SOURCE Solutions

- ✓ Global Sourcing Solution
- ✓ Obsolete Management
- ✓ Cost Control Management
- ✓ Shortage Management
- ✓ Alternative Solution
- ✓ Excess Inventory Management