



**THE DATASHEET OF  
IXTN660N04T4**



# 40V High-Current TrenchT4™ Power MOSFETs

Ideal for synchronous rectification applications

JUNE 2016

## OVERVIEW

These 40V TrenchT4™ Power MOSFETs constitute a new generation of high-current Trench devices from IXYS Corporation (NASDAQ: IXYS), a global manufacturer of power semiconductors and integrated circuits (ICs) for energy efficiency, power management, transportation, medical, and motor control applications. Available at either 270A or 340A current rating, they are optimized for synchronous rectification in switched-mode power conversion applications.

With on-state resistance as low as 1.7 milliohms (devices with less than 1 milliohm on-resistance soon to be released), these TrenchT4™ devices enable a reduction in the number of MOSFETs needed, especially in synchronous rectification. Paralleling multiple devices may not be necessary due to their high-current carrying capability and high power density, thereby simplifying the power system and improving its reliability at the same time.

The new MOSFETs are avalanche rated as well and can withstand a junction temperature up to 175°C. They are thus robust against device failure caused by voltage transients and the accidental turn-on of parasitic bipolar transistors inherent in the MOSFET structure. Also, the low reverse recovery charge of the body diode mitigates voltage overshoots and reduces electromagnetic interference (EMI).

Ideal applications include synchronous rectification, high-current switching power supplies, battery powered electric motors, resonant-mode power supplies, electronic ballasts, Class-D audio amplifiers, electric forklifts, and cordless power tools.

These new 40V TrenchT4™ Power MOSFETs are available in the following international standard size packages: TO-220, TO-263(3- or 7-lead), SOT-227, and TO-247. Some example part numbers are IXTH270N04T4, IXTP270N04T4, IXTA340N04T4-7, and IXTH340N04T4; the first two are rated at 270A and the last two 340A.

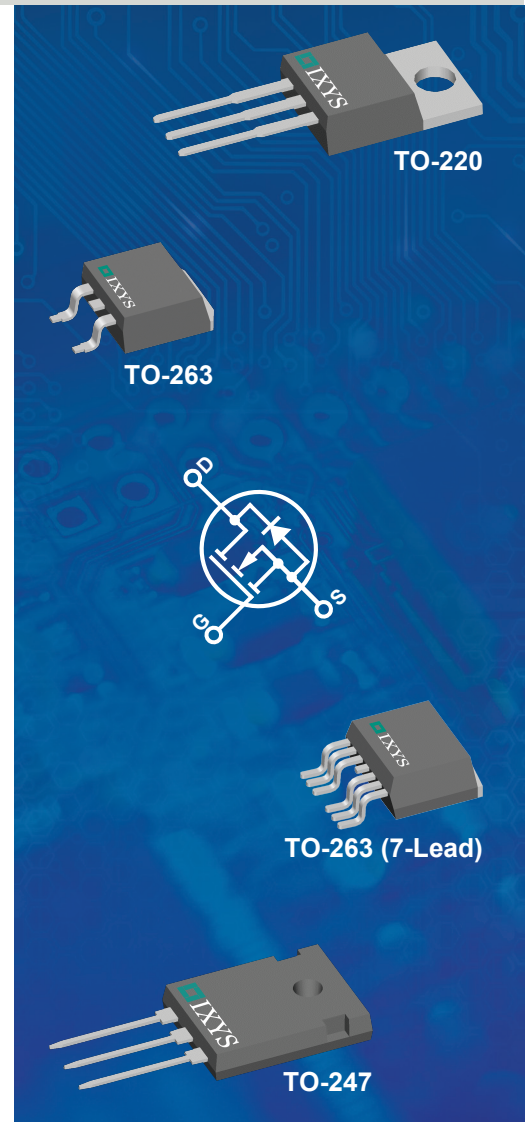

## FEATURES

- Ultra low on-resistance  $R_{DS(on)}$
- High current handling capability
- Avalanche rated
- 175°C operating temperature
- International standard packages

## ADVANTAGES

- High power density
- Easy to mount
- Space savings

## APPLICATIONS

- Synchronous rectification
- High current switching power supplies
- Battery powered electric motors
- Resonant-mode power supplies
- Electronic ballasts
- Class D audio amplifiers
- Electric forklifts
- Cordless power tools

# Available Parts

Part Number	V <sub>DSS</sub> (V)	I <sub>DS(on)</sub> T <sub>c</sub> = 25°C (A)	R <sub>DS(on)</sub> max T <sub>j</sub> = 25°C (mΩ)	Q <sub>g(on)</sub> typ (nC)	C <sub>iss</sub> typ (pF)	t <sub>rr</sub> typ (ns)	R <sub>th(jc)</sub> max (°C/W)	P <sub>D</sub> max (W)	Package Type
IXTA270N04T4	40	270	2.2	182	9140	48	0.4	375	TO-263
IXTA270N04T4-7	40	270	2.2	182	9140	48	0.4	375	TO-263 (7-Lead)
IXTH270N04T4	40	270	2.4	182	9140	48	0.4	375	TO-247
IXTP270N04T4	40	270	2.4	182	9140	48	0.4	375	TO-220
IXTA340N04T4	40	340	1.7	256	13000	43	0.31	480	TO-263
IXTA340N04T4-7	40	340	1.7	256	13000	43	0.31	480	TO-263 (7-Lead)
IXTH340N04T4	40	340	1.9	256	13000	43	0.31	480	TO-247
IXTP340N04T4	40	340	1.9	256	13000	43	0.31	480	TO-220

## Application Examples

Application Circuits Legend

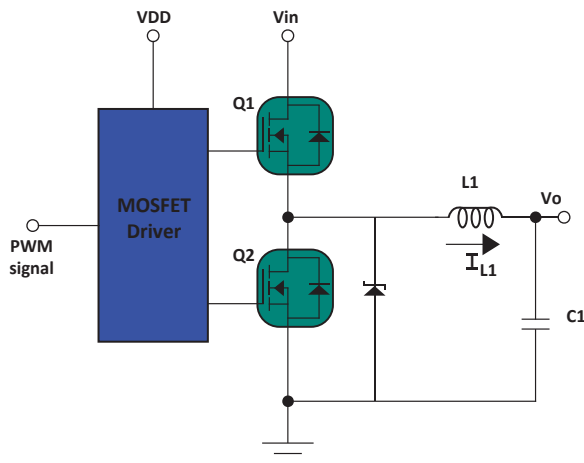

Figure 1: Synchronous buck converter

Figure 1 represents a DC-DC synchronous buck converter circuit which makes use of the TrenchT4™ IXTA340N04T4 (Q1 and Q2). Q1 functions as the high-side switch and Q2 the low-side synchronous switch in place of a diode. With an R<sub>DS(on)</sub> of 1.7mΩ, the IXTA340N04T4 enables the converter to achieve a higher efficiency.

Figure 2 illustrates a brushed DC motor drive typically used in cordless power tools. Four high-current TrenchT4™ IXTP270N04T4 MOSFETs (M1, M2, M3, and M4) are used to form a full-bridge stage that drives a brushed DC motor. These avalanche-rated MOSFETs ensure the reliability of the system.

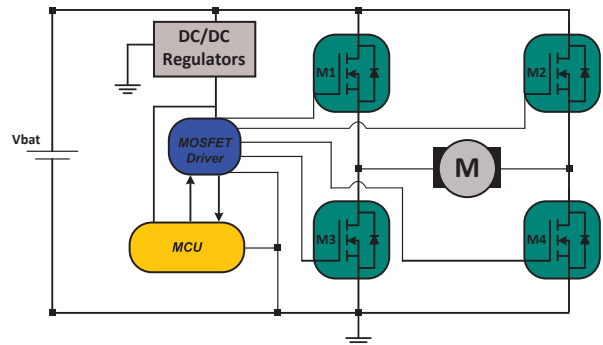

Figure 2: Brushed DC motor (cordless tools)

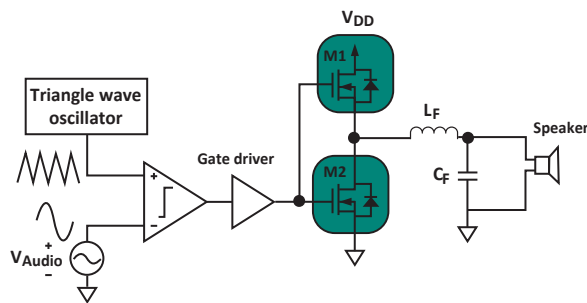

Figure 3: Half-bridge Class D audio amplifier

Figure 3 demonstrates a simplified block diagram of a Class D audio amplifier. The audio signal is compared with a triangle wave, and a corresponding PWM (Pulse Width Modulation) signal is generated, which drives the half-bridge stage through a gate driver. The output is then low-pass filtered and reconstructed for the speaker. The half-bridge is constructed with two IXTP340N04T4 TrenchT4™ MOSFETs (M1, M2).



---

Disclaimer Notice - Information furnished is believed to be accurate and reliable. However, users should independently evaluate the suitability of and test each product selected for their own applications. Littelfuse products are not designed for, and may not be used in, all applications. Read complete Disclaimer Notice at [www.littelfuse.com/disclaimer-electronics](http://www.littelfuse.com/disclaimer-electronics).





## Looking for pricing, stock, or lifecycle information?

Click below to explore more details on WIN SOURCE:

 [View IXTN660N04T4 on WIN SOURCE](#)

 [IXYS Information](#)

## Optimize Your Supply Chain with WIN SOURCE Solutions

-  Global Sourcing Solution
-  Obsolete Management
-  Cost Control Management
-  Shortage Management
-  Alternative Solution
-  Excess Inventory Management