



**THE DATASHEET OF
AS358AP-E1**



Description

The AS358/358A/358B consists of two independent, high gain and internally frequency compensated operational amplifiers, they are specifically designed to operate from a single power supply. Operation from split power supply is also possible and the low power supply current drain is independent of the magnitude of the power supply voltages. Typical applications include transducer amplifiers, DC gain blocks and most conventional operational amplifier circuits.

The AS358/358A/358B series is compatible with industry standard 358. The AS358A has more stringent input offset voltage than the AS358.

The AS358 is available in PDIP-8, TDIP-8, SO-8, TSSOP-8 and MSOP-8 packages, the AS358A is available in PDIP-8 and SO-8 packages and AS358B is available in TSSOP-8 package.

Features

- Internally Frequency Compensated for Unity Gain
- Large Voltage Gain: 100dB (Typical)
- Low Input Bias Current: 20nA (Typical)
- Low Input Offset Voltage: 2mV (Typical)
- Low Supply Current: 0.5mA (Typical)
- Wide Power Supply Voltage:
 - Single Supply: 3V to 36V
 - Dual Supplies: $\pm 1.5V$ to $\pm 18V$
- Input Common Mode Voltage Range Includes Ground
- Large Output Voltage Swing: 0V to $V_{CC} - 1.5V$
- Lead-Free Packages: SO-8, PDIP-8 and TSSOP-8
 - **Totally Lead-Free; RoHS Compliant (Notes 1 & 2)**
- Lead-Free Packages, Available in "Green" Molding Compound: SO-8, PDIP-8, TDIP-8, TSSOP-8 and MSOP-8
 - **Totally Lead-Free & Fully RoHS Compliant (Notes 1 & 2)**
 - **Halogen and Antimony Free. "Green" Device (Note 3)**

- Notes:
1. No purposely added lead. Fully EU Directive 2002/95/EC (RoHS), 2011/65/EU (RoHS 2) & 2015/863/EU (RoHS 3) compliant.
 2. See <https://www.diodes.com/quality/lead-free/> for more information about Diodes Incorporated's definitions of Halogen- and Antimony-free, "Green" and Lead-free.
 3. Halogen- and Antimony-free "Green" products are defined as those which contain <900ppm bromine, <900ppm chlorine (<1500ppm total Br + Cl) and <1000ppm antimony compounds.

Pin Assignments

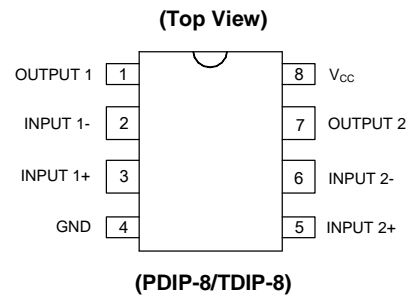
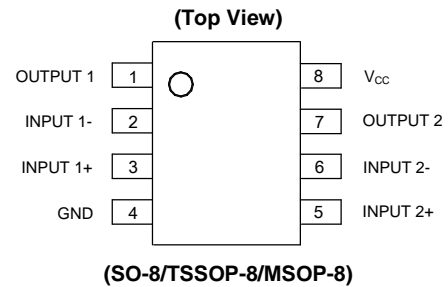

Applications

- Battery Charger
- Cordless Telephone
- Switching Power Supply

Typical Applications Circuit

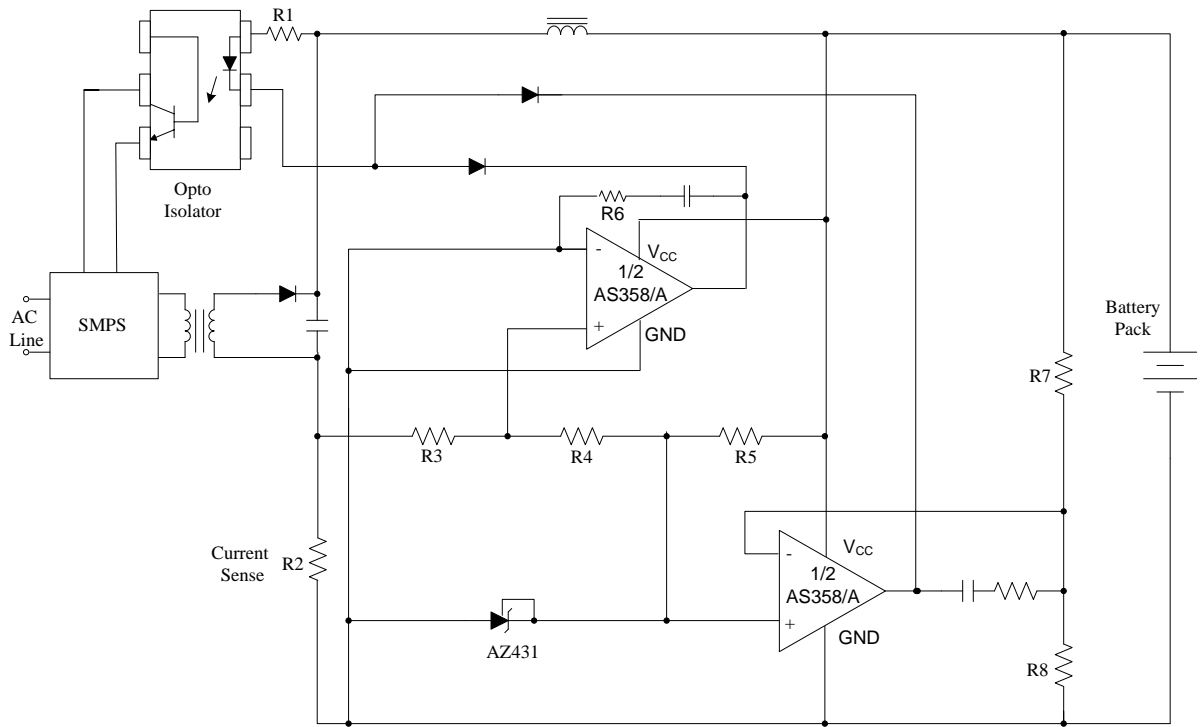

Battery Charger

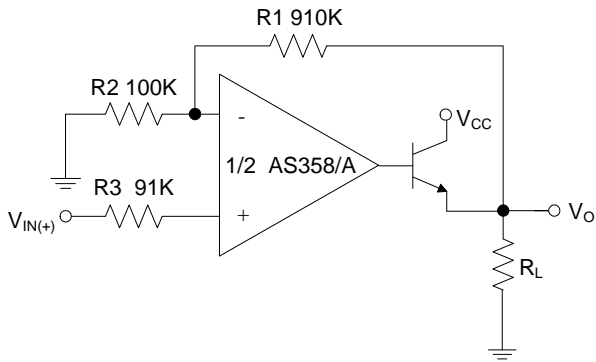

Power Amplifier

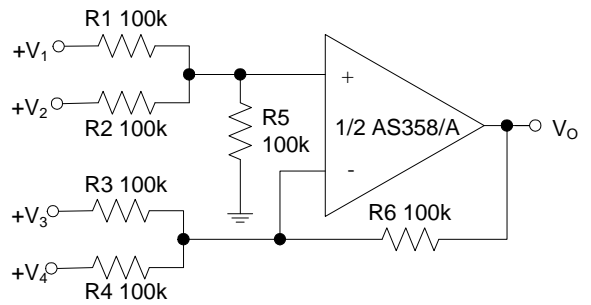

DC Summing Amplifier

Typical Applications Circuit (Cont.)

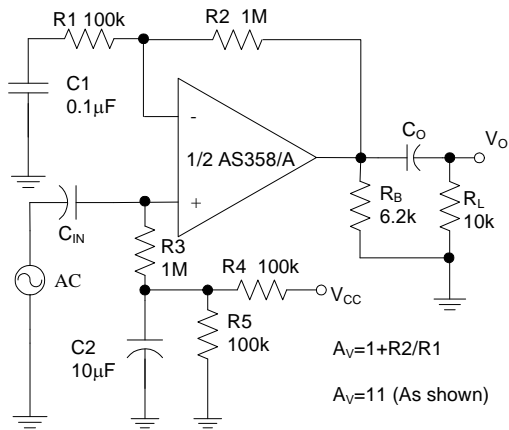

AC Coupled Non-Inverting Amplifier

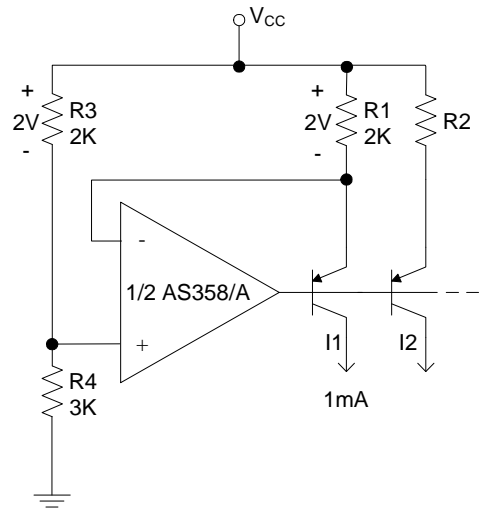

Fixed Current Sources

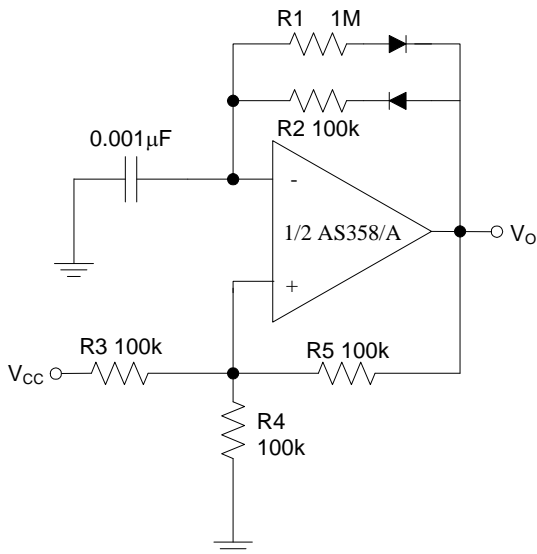

Pulse Generator

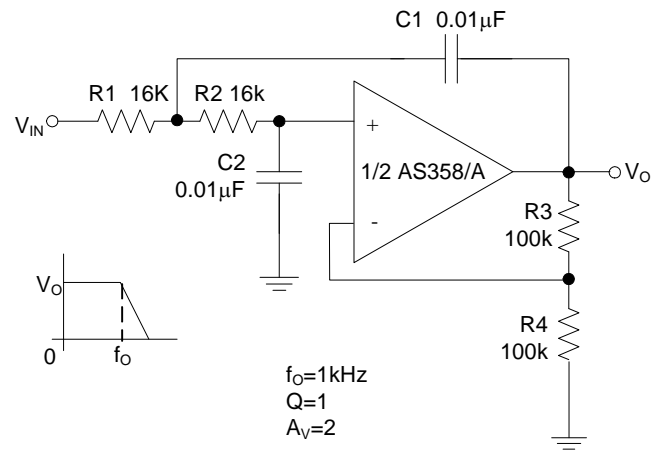

DC Coupled Low-Pass Active Filter

Functional Block Diagram

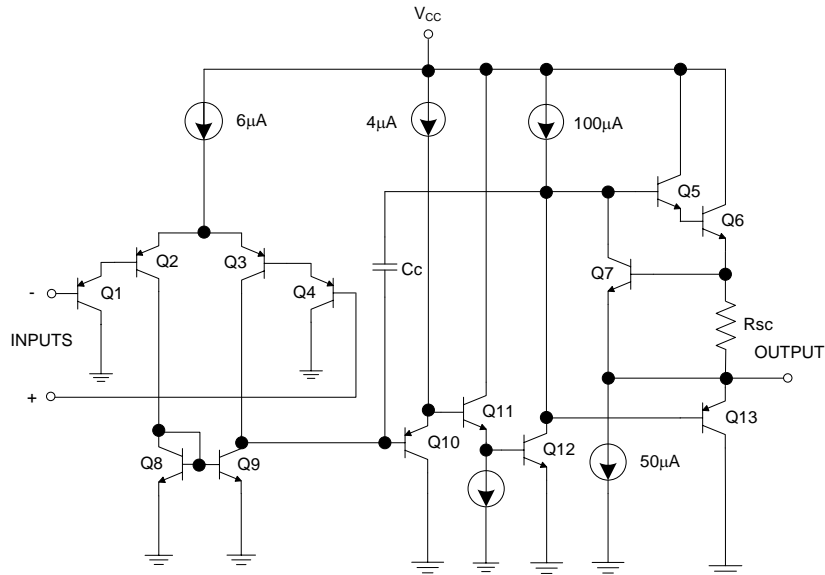

Absolute Maximum Ratings (Notes 4 & 5)

Symbol	Parameter	Rating		Unit
V _{CC}	Power Supply Voltage	40		V
V _{ID}	Differential Input Voltage	40		V
V _{IC}	Input Voltage	-0.3 to 40		V
P _D	Power Dissipation (T _A = +25°C)	PDIP-8	830	mW
		SO-8	550	
		TSSOP-8	500	
		MSOP-8	470	
T _J	Operating Junction Temperature	+150		°C
T _{STG}	Storage Temperature Range	-65 to +150		°C
T _{LEAD}	Lead Temperature (Soldering, 10 Seconds)	+260		°C

Notes: 4. Stresses greater than those listed under “Absolute Maximum Ratings” may cause permanent damage to the device. These are stress ratings only, and functional operation of the device at these or any other conditions beyond those indicated under “Recommended Operating Conditions” is not implied. Exposure to “Absolute Maximum Ratings” for extended periods may affect device reliability.

5. ESD sensitivity.

Recommended Operating Conditions

Symbol	Parameter	Min	Max	Unit
V _{CC}	Supply Voltage	3	36	V
T _A	Ambient Operating Temperature Range	-40	+85	°C

Electrical Characteristics (Limits in standard typeface are for $T_A = +25^\circ\text{C}$, **bold** typeface applies over -40°C to $+85^\circ\text{C}$ (Note 6), $V_{CC} = 5\text{V}$, $\text{GND} = 0\text{V}$, unless otherwise specified.)

Symbol	Parameter		Conditions	Min	Typ	Max	Unit	
V_{IO}	Input Offset Voltage		$V_O = 1.4\text{V}$, $R_S = 0\Omega$, $V_{CC} = 5\text{V to } 30\text{V}$	AS358	—	2	5	mV
					—	—	7	
				AS358A	—	2	3	
					—	—	5	
			AS358B	—	—	2		
				—	—	4		
$\Delta V_{IO}/\Delta T$	Average Temperature Coefficient of Input Offset Voltage		$T_A = -40^\circ\text{C to } +85^\circ\text{C}$	—	7	—	$\mu\text{V}/^\circ\text{C}$	
I_{BIAS}	Input Bias Current		I_{IN+} or I_{IN-} , $V_{CM} = 0\text{V}$	—	20	200	nA	
				—	—	200		
I_{IO}	Input Offset Current		$I_{IN+} - I_{IN-}$, $V_{CM} = 0\text{V}$	—	5	30	nA	
				—	—	100		
V_{IR}	Input Common Mode Voltage Range (Note 7)		$V_{CC} = 30\text{V}$	0	—	$V_{CC} - 1.5$	V	
I_{CC}	Supply Current		$T_A = -40^\circ\text{C to } +85^\circ\text{C}$, $R_L = \infty$, $V_{CC} = 30\text{V}$	—	0.7	2	mA	
			$T_A = -40^\circ\text{C to } +85^\circ\text{C}$, $R_L = \infty$, $V_{CC} = 5\text{V}$	—	0.5	1.2		
G_V	Large Signal Voltage Gain		$V_{CC} = 15\text{V}$, $V_O = 1\text{V to } 11\text{V}$, $R_L \geq 2\text{k}\Omega$	85	100	—	dB	
				80	—	—		
CMRR	Common Mode Rejection Ratio		DC, $V_{CM} = 0\text{V to } (V_{CC} - 1.5)\text{V}$	60	70	—	dB	
				60	—	—		
PSRR	Power Supply Rejection Ratio		$V_{CC} = 5\text{V to } 30\text{V}$	70	100	—	dB	
				60	—	—		
CS	Channel Separation		$f = 1\text{kHz to } 20\text{kHz}$	—	-120	—	dB	
I_{SOURCE}	Output Current	Source	$V_{IN+} = 1\text{V}$, $V_{IN-} = 0\text{V}$, $V_{CC} = 15\text{V}$, $V_O = 2\text{V}$	20	40	—	mA	
				20	—	—		
I_{SINK}	Output Current	Sink	$V_{IN+} = 0\text{V}$, $V_{IN-} = 1\text{V}$, $V_{CC} = 15\text{V}$, $V_O = 2\text{V}$	10	15	—	mA	
			$V_{IN+} = 0\text{V}$, $V_{IN-} = 1\text{V}$, $V_{CC} = 15\text{V}$, $V_O = 0.2\text{V}$	5	—	—		
				12	50	—	μA	
I_{SC}	Output Short Circuit Current to Ground		$V_{CC} = 15\text{V}$	—	40	60	mA	
V_{OH}	Output Voltage Swing		$V_{CC} = 30\text{V}$, $R_L = 2\text{k}\Omega$	26	—	—	V	
				26	—	—		
			$V_{CC} = 30\text{V}$, $R_L = 10\text{k}\Omega$	27	28	—		
				27	—	—		
V_{OL}			$V_{CC} = 5\text{V}$, $R_L = 10\text{k}\Omega$	—	5	20	mV	
				—	—	30		
θ_{JC}	Thermal Resistance (Junction to Case)		SO-8	—	17	—	$^\circ\text{C}/\text{W}$	
			TSSOP-8	—	47	—		
			MSOP-8	—	22	—		
θ_{JA}	Thermal Resistance (Junction to Ambient)		SO-8	—	115	—	$^\circ\text{C}/\text{W}$	
			TSSOP-8	—	209	—		
			MSOP-8	—	160	—		

Notes: 6. Limits over the full temperature are guaranteed by design, but not tested in production.
7. The input common-mode voltage of either input signal voltage should not be allowed to go negatively by more than 0.3V (at $+25^\circ\text{C}$). The upper end of the common-mode voltage range is $V_{CC} - 1.5\text{V}$ (at $+25^\circ\text{C}$), but either or both inputs can go to $+36\text{V}$ without damages, independent of the magnitude of the V_{CC} .

Performance Characteristics

Input Voltage Range

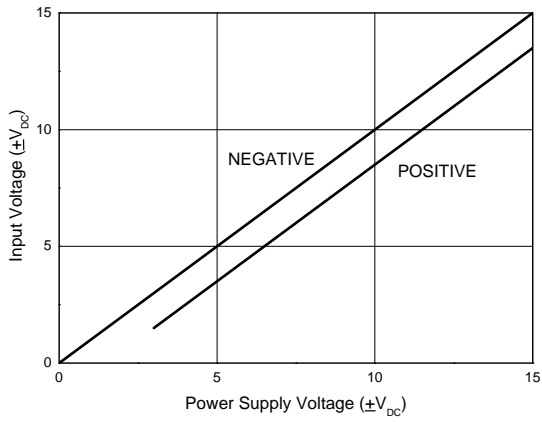

Input Current

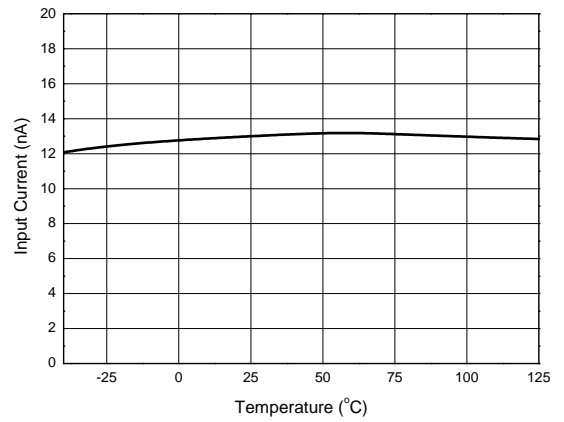

Supply Current

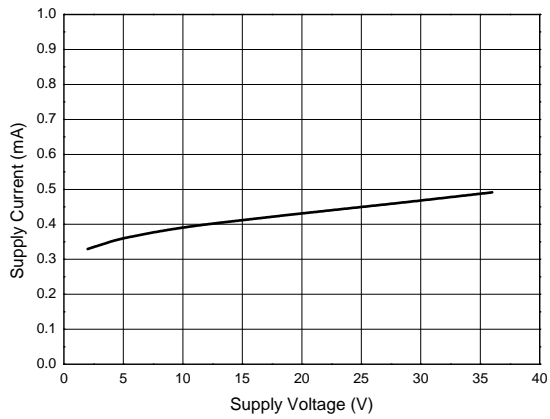

Voltage Gain

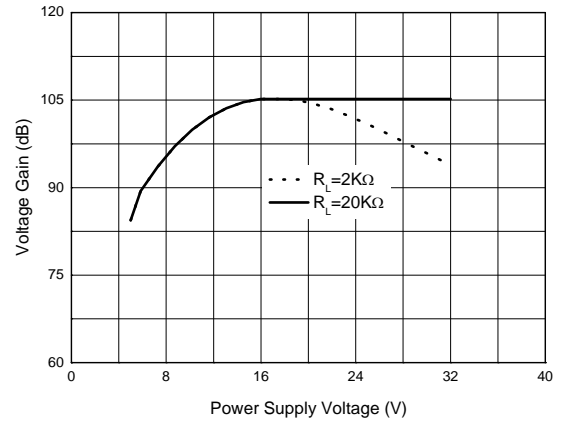

Open Loop Frequency Response

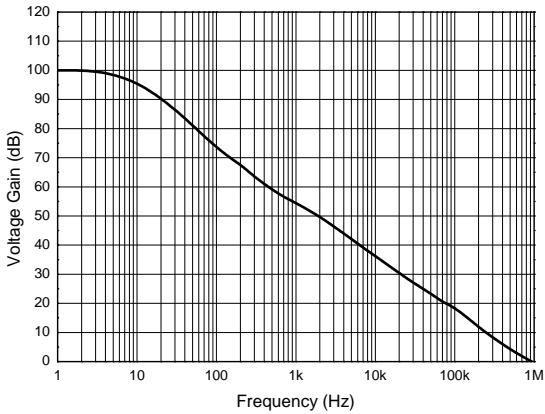

Voltage Follower Pulse Response

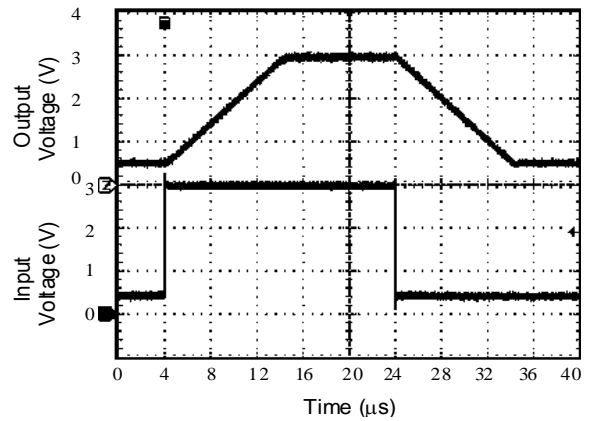

Performance Characteristics (Cont.)

Voltage Follower Pulse Response (Small Signal)

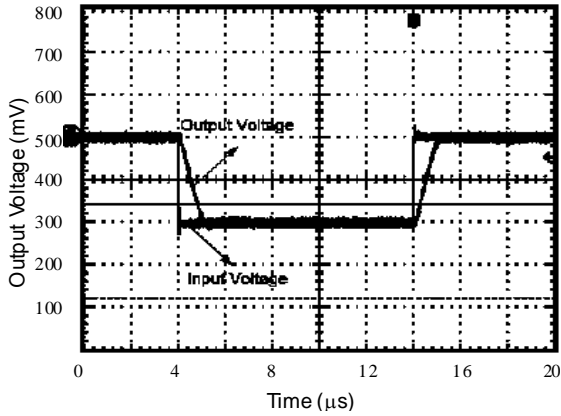

Large Signal Frequency Response

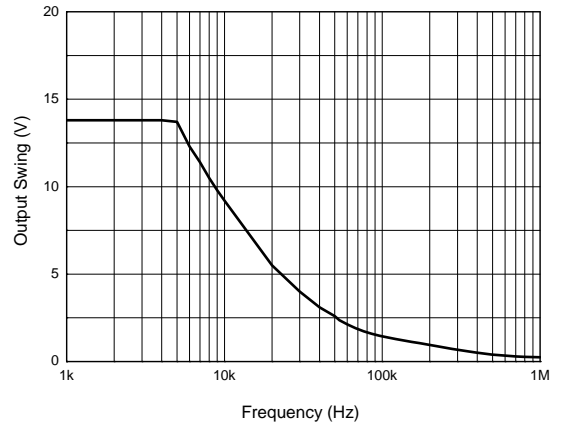

Output Characteristics: Current Sourcing

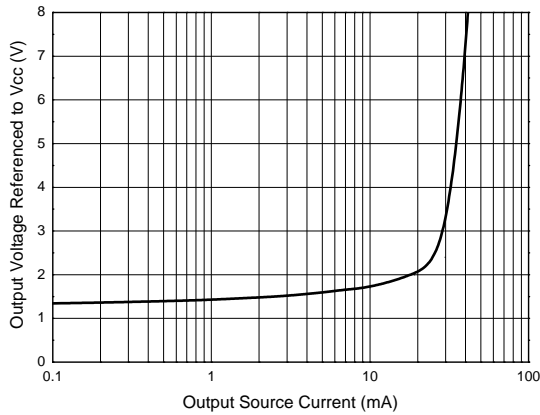

Output Characteristics: Current Sinking

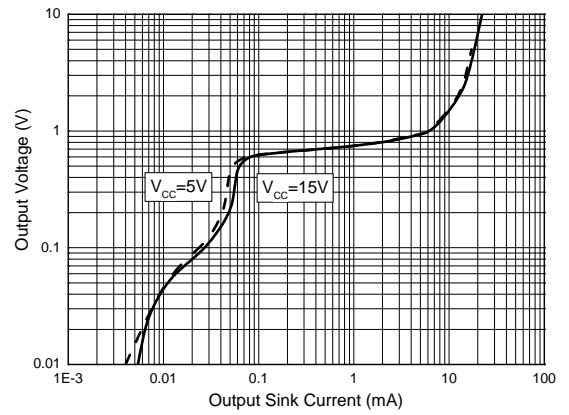

Current Limiting

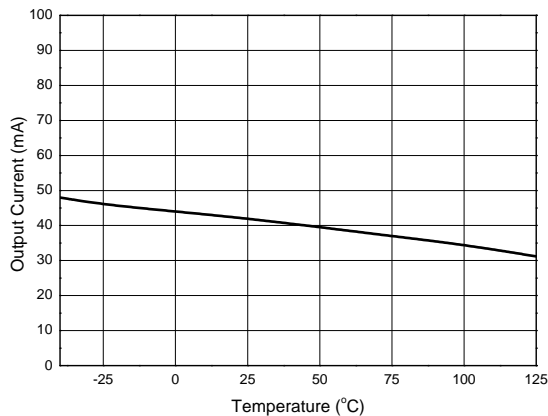

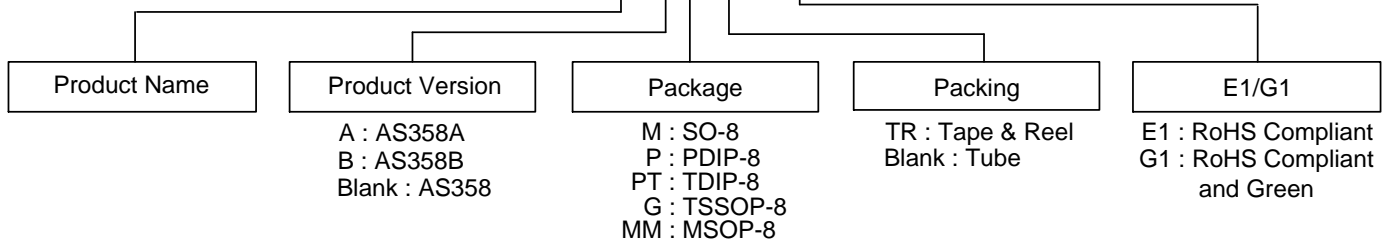
Ordering Information
AS358X XX XX - XX

Part Number	Package (Note 9)	Temperature Range	RoHS Compliant Lead Free / Green	Marking ID	Packing	Status (Note 8)	Alternative		
AS358M-E1	SO-8	-40°C to +85°C	Lead Free	AS358M-E1	100/Tube	End of Life	AS358MTR-G1		
AS358M-G1			Green	AS358M-G1					
AS358MTR-E1			Lead Free	AS358M-E1	4000/Tape & Reel	NRND	AS358MTR-G1		
AS358MTR-G1			Green	AS358M-G1		In Production	—		
AS358AM-E1			PDIP-8	-40°C to +85°C	Lead Free	AS358AM-E1	100/Tube	End of Life	AS358AMTR-G1
AS358AM-G1					Green	AS358AM-G1			
AS358AMTR-E1					Lead Free	AS358AM-E1	4000/Tape & Reel	NRND	AS358AMTR-G1
AS358AMTR-G1					Green	AS358AM-G1		In Production	—
AS358P-E1	PDIP-8	-40°C to +85°C	Lead Free	AS358P-E1	50/Tube	In Production	—		
AS358P-G1			Green	AS358P-G1		In Production	—		
AS358AP-E1			Lead Free	AS358AP-E1		In Production	—		
AS358AP-G1			Green	AS358AP-G1		End of Life	—		
AS358PT-G1	TDIP-8	-40°C to +85°C	Green	AS358PT-G1	50/Tube	In Production	—		
AS358GTR-E1	TSSOP-8	-40°C to +85°C	Lead Free	EG3A	4000/Tape & Reel	NRND	AS358GTR-G1		
AS358GTR-G1			Green	GG3A		In Production	—		
AS358BGTR-G1			Green	GG3F		In Production	—		
AS358MMTR-E1	MSOP-8	-40°C to +85°C	Lead Free	AS358MM-E1	3000/Tape & Reel	End of Life	AS358MMTR-G1		
AS358MMTR-G1			Green	AS358MM-G1		In Production	—		

Notes: 8. NRND: Not Recommended for New Design
 9. For packaging details, go to our website at: <https://www.diodes.com/design/support/packaging/diodes-packaging/>.

Marking Information

(1) SO-8

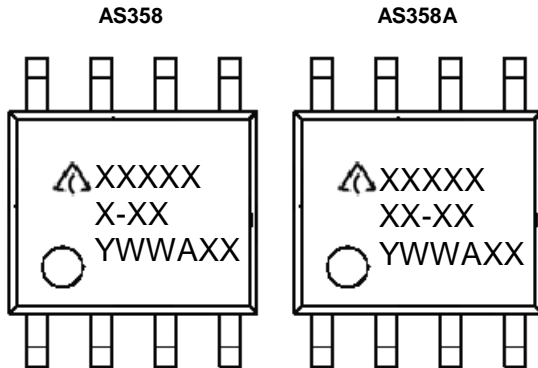

First and Second Lines: Logo and Marking ID
 Third Line: Date Code
 Y: Year
 WW: Work Week of Molding
 A: Assembly House Code
 XX: Internal Code

(2) MSOP-8

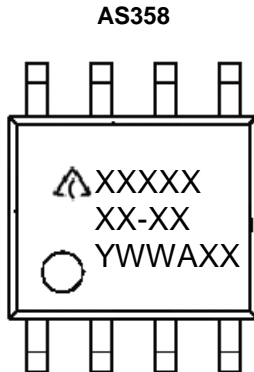

First and Second Lines: Logo and Marking ID
 Third Line: Date Code
 Y: Year
 WW: Work Week of Molding
 A: Assembly House Code
 XX: Internal Code

(3) PDIP-8

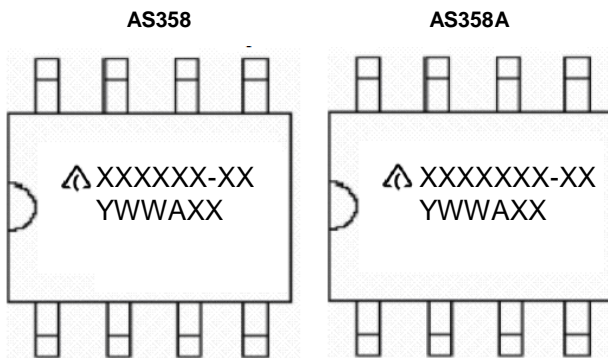

First Line: Logo and Marking ID
 Second Line: Date Code
 Y: Year
 WW: Work Week of Molding
 A: Assembly House Code
 XX: Internal Code

Marking Information (Cont.)

(4) TDIP-8

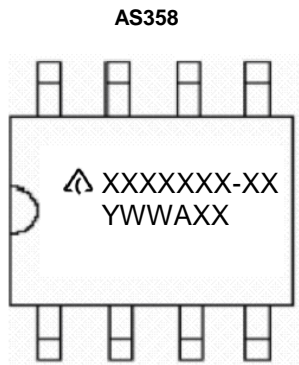

First Line: Logo and Marking ID
 Second Line: Date Code
 Y: Year
 WW: Work Week of Molding
 A: Assembly House Code
 XX: Internal Code

(5) TSSOP-8

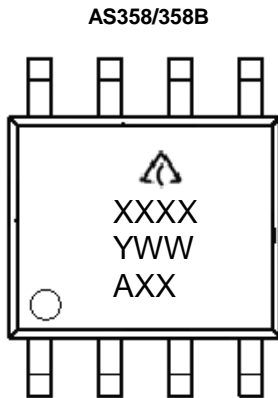

First Line: Logo
 Second Line: Marking ID
 Third and Fourth Lines: Date Code
 Y: Year
 WW: Work Week of Molding
 A: Assembly House Code
 XX: Internal Code

Package Outline Dimensions (All dimensions in mm(inch).)

(1) Package Type: PDIP-8

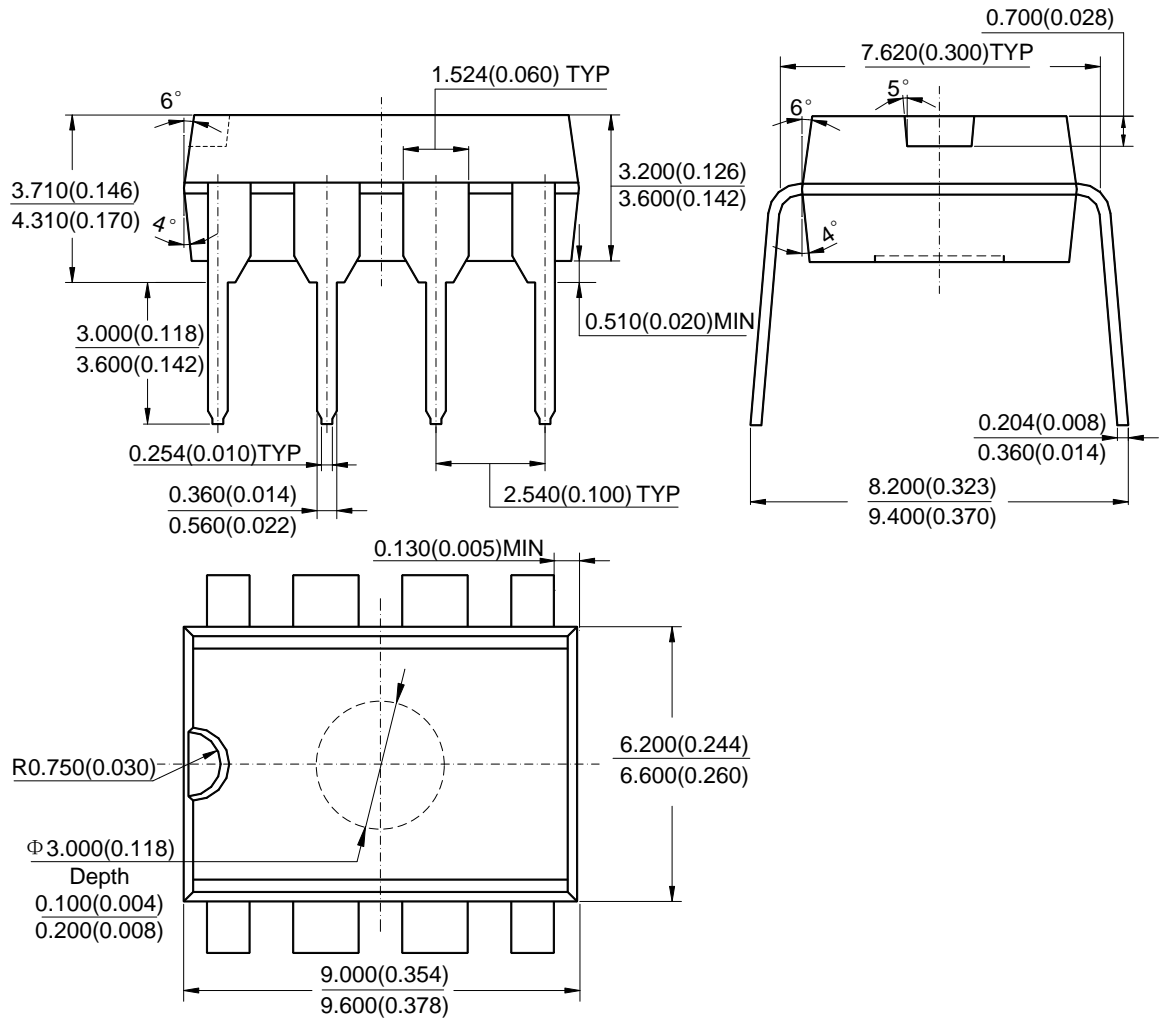

Note: Eject hole, oriented hole and mold mark is optional.

Package Outline Dimensions (Cont. All dimensions in mm(inch).)

(2) Package Type: TDIP-8

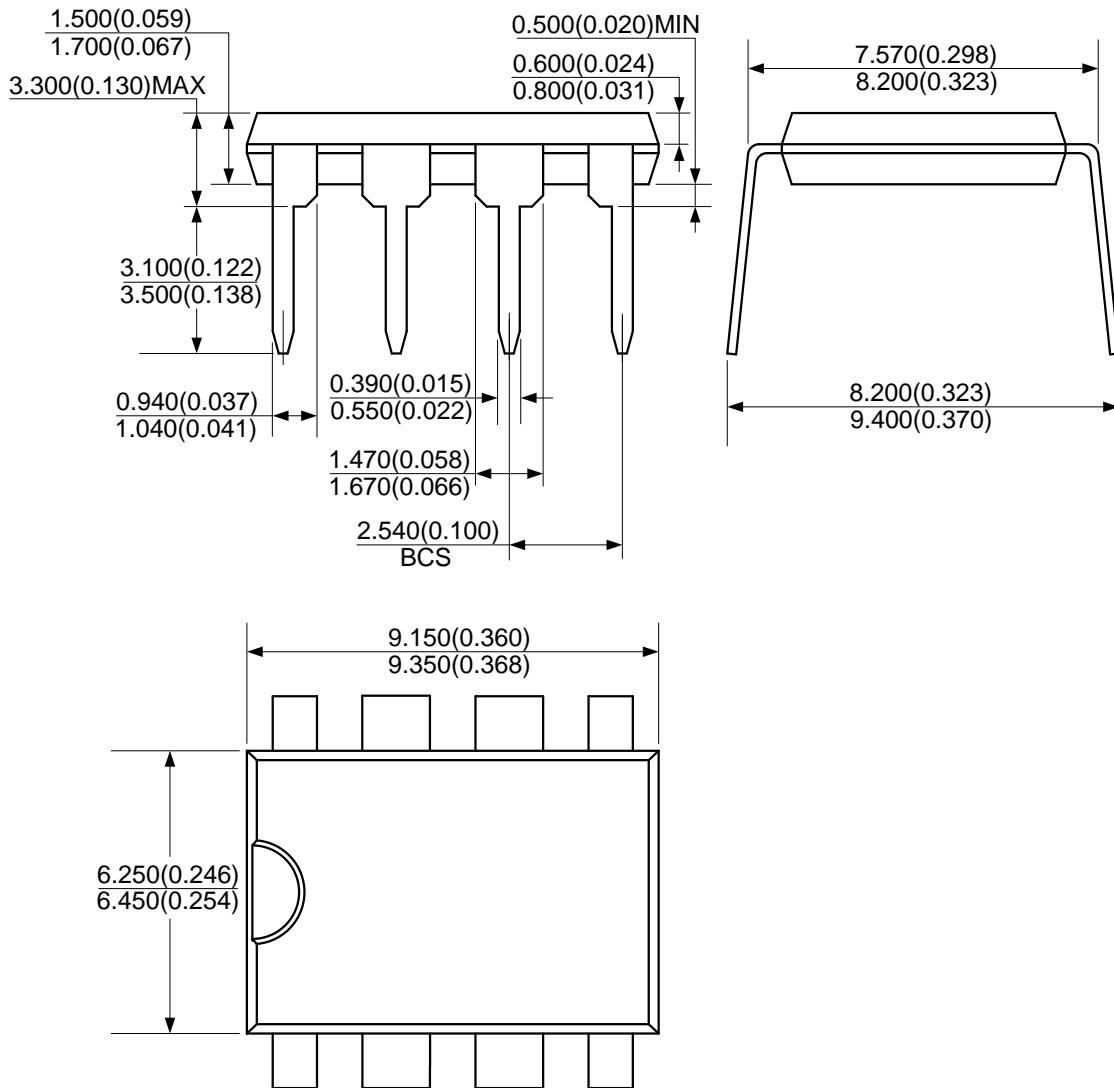

Note: Eject hole, oriented hole and mold mark is optional.

Package Outline Dimensions (Cont. All dimensions in mm(inch).)

(3) Package Type: SO-8

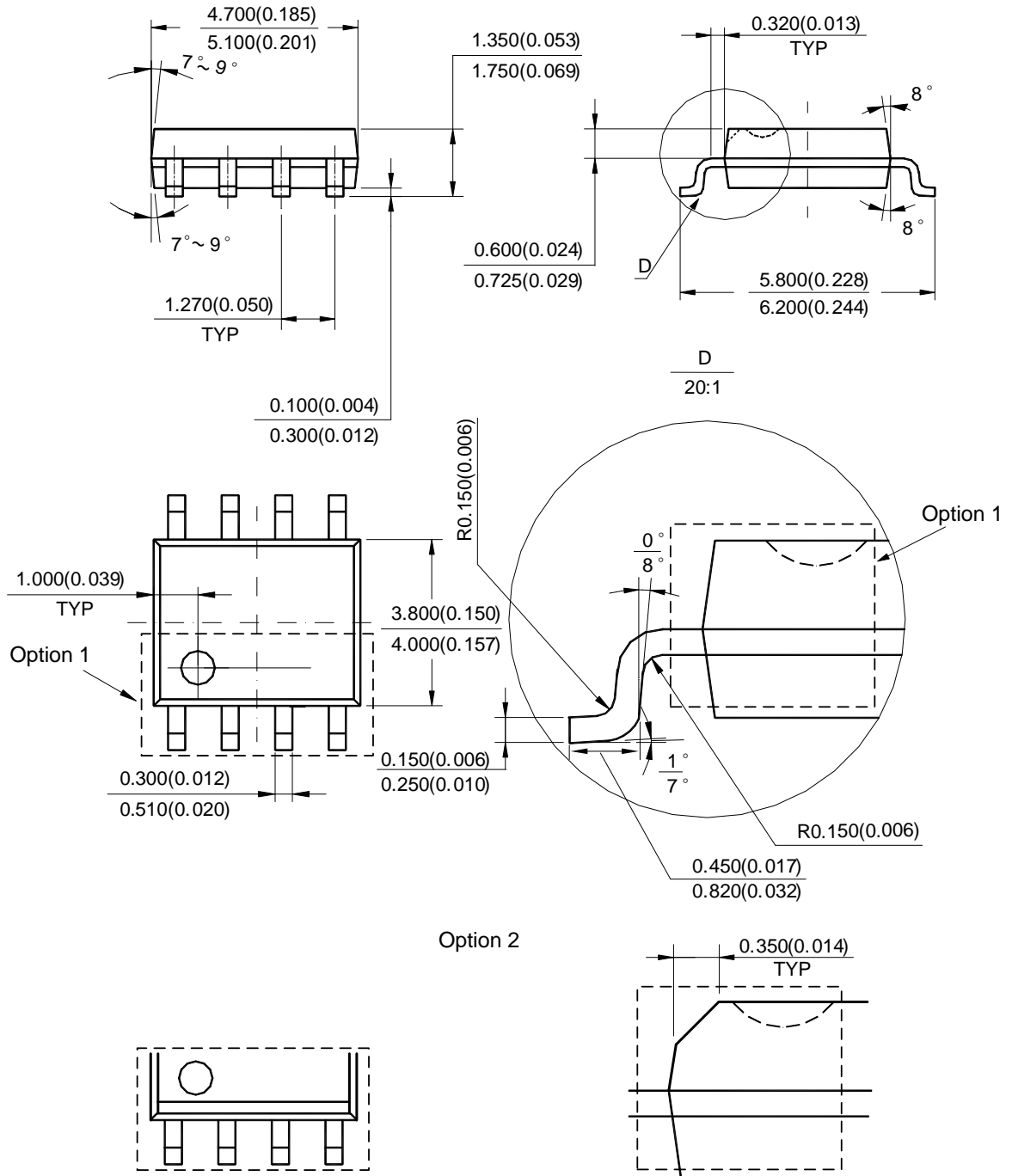

Note: Eject hole, oriented hole and mold mark is optional.

Package Outline Dimensions (Cont. All dimensions in mm(inch).)

(4) Package Type: TSSOP-8

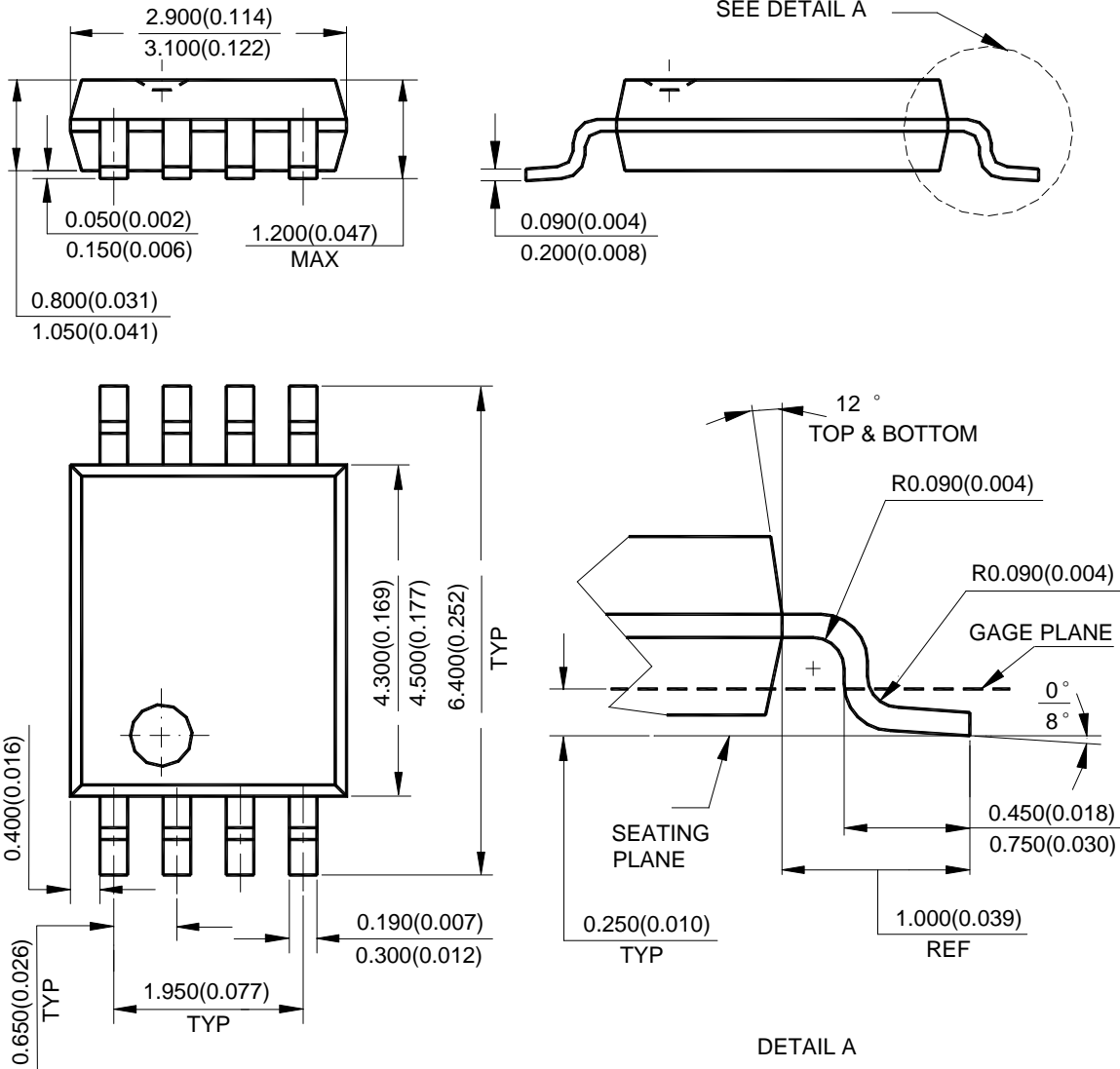

Note: Eject hole, oriented hole and mold mark is optional.

Package Outline Dimensions (Cont. All dimensions in mm(inch).)

(5) Package Type: MSOP-8

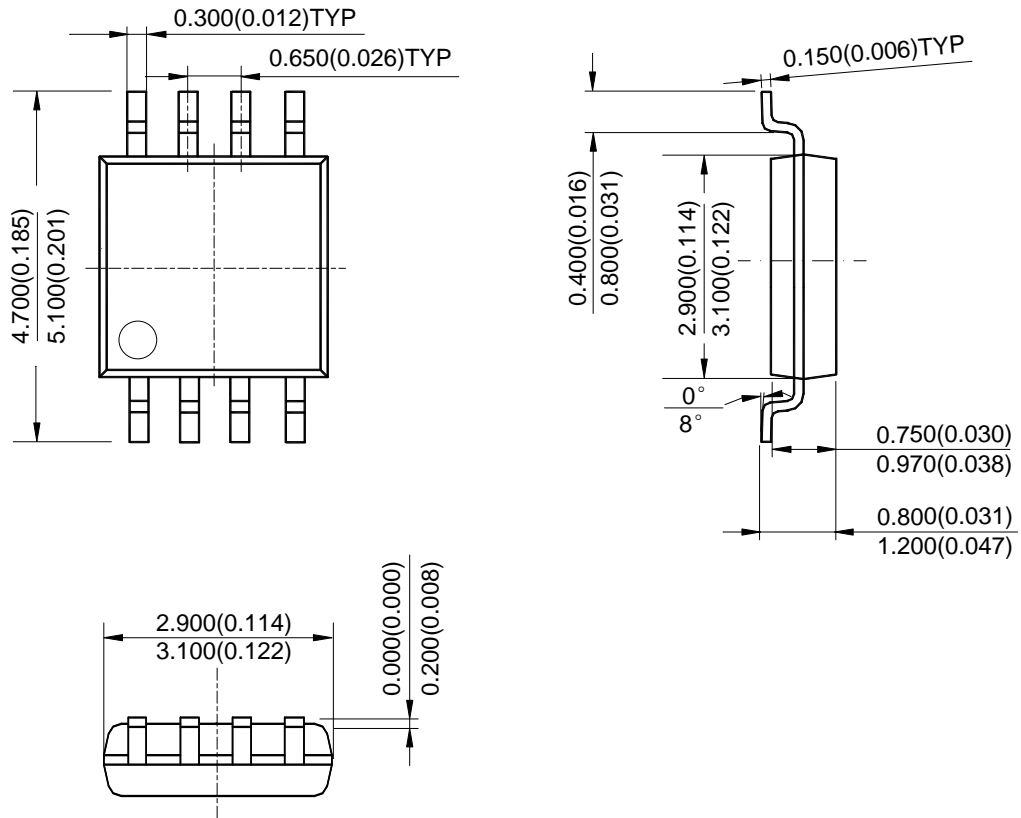

Note: Eject hole, oriented hole and mold mark is optional.

Suggested Pad Layout

(1) Package Type: SO-8

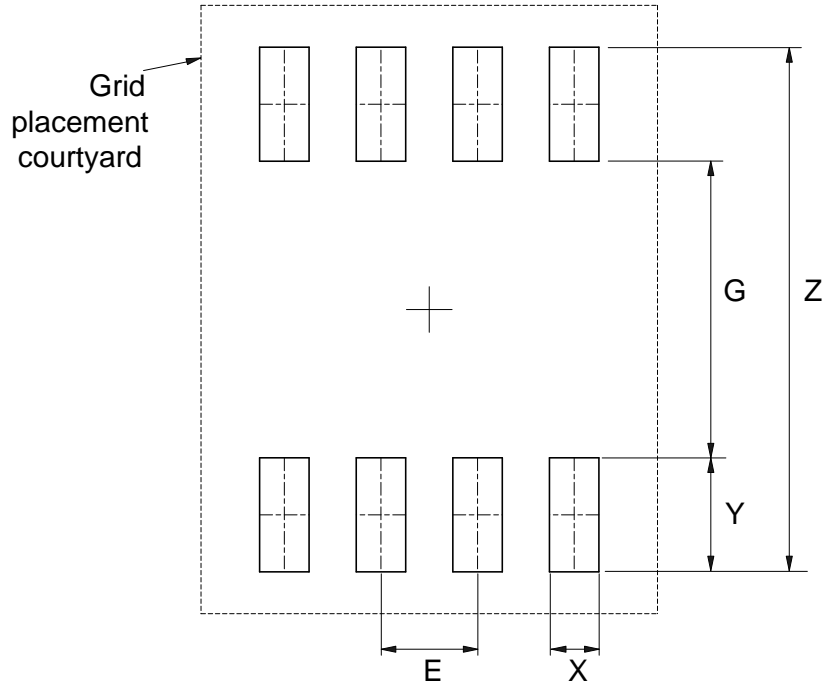

Dimensions	Z (mm)/(inch)	G (mm)/(inch)	X (mm)/(inch)	Y (mm)/(inch)	E (mm)/(inch)
Value	6.900/0.272	3.900/0.154	0.650/0.026	1.500/0.059	1.270/0.050

Suggested Pad Layout (Cont.)

(2) Package Type: TSSOP-8

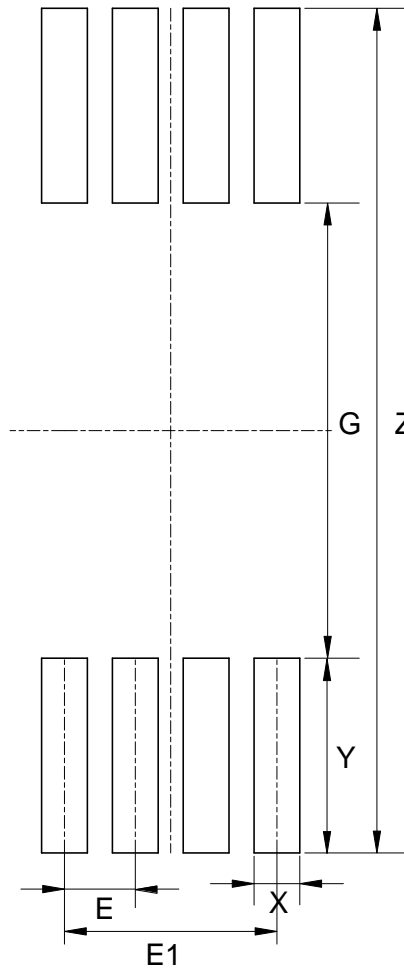

Dimensions	Z (mm)/(inch)	G (mm)/(inch)	X (mm)/(inch)	Y (mm)/(inch)	E (mm)/(inch)	E1 (mm)/(inch)
Value	7.720/0.304	4.160/0.164	0.420/0.017	1.780/0.070	0.650/0.026	1.950/0.077

Suggested Pad Layout (Cont.)

(3) Package Type: MSOP-8

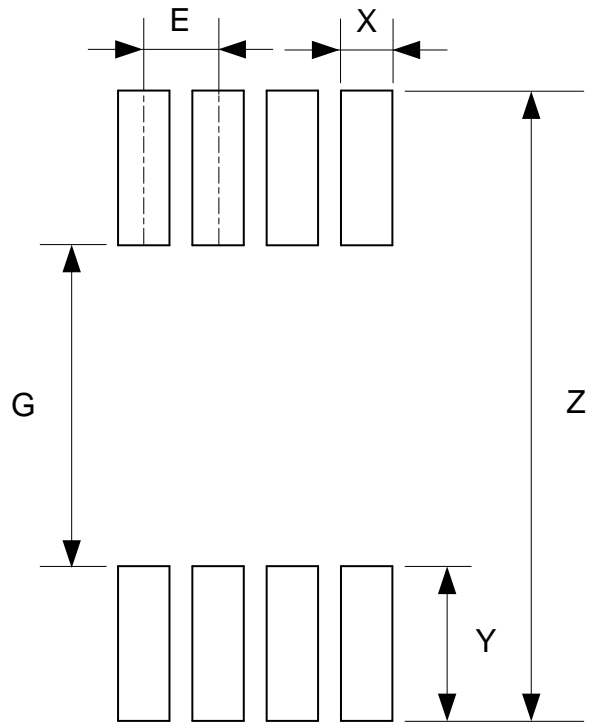

Dimensions	Z (mm)/(inch)	G (mm)/(inch)	X (mm)/(inch)	Y (mm)/(inch)	E (mm)/(inch)
Value	5.500/0.217	2.800/0.110	0.450/0.018	1.350/0.053	0.650/0.026

IMPORTANT NOTICE

DIODES INCORPORATED MAKES NO WARRANTY OF ANY KIND, EXPRESS OR IMPLIED, WITH REGARDS TO THIS DOCUMENT, INCLUDING, BUT NOT LIMITED TO, THE IMPLIED WARRANTIES OF MERCHANTABILITY AND FITNESS FOR A PARTICULAR PURPOSE (AND THEIR EQUIVALENTS UNDER THE LAWS OF ANY JURISDICTION).

Diodes Incorporated and its subsidiaries reserve the right to make modifications, enhancements, improvements, corrections or other changes without further notice to this document and any product described herein. Diodes Incorporated does not assume any liability arising out of the application or use of this document or any product described herein; neither does Diodes Incorporated convey any license under its patent or trademark rights, nor the rights of others. Any Customer or user of this document or products described herein in such applications shall assume all risks of such use and will agree to hold Diodes Incorporated and all the companies whose products are represented on Diodes Incorporated website, harmless against all damages.

Diodes Incorporated does not warrant or accept any liability whatsoever in respect of any products purchased through unauthorized sales channel. Should Customers purchase or use Diodes Incorporated products for any unintended or unauthorized application, Customers shall indemnify and hold Diodes Incorporated and its representatives harmless against all claims, damages, expenses, and attorney fees arising out of, directly or indirectly, any claim of personal injury or death associated with such unintended or unauthorized application.

Products described herein may be covered by one or more United States, international or foreign patents pending. Product names and markings noted herein may also be covered by one or more United States, international or foreign trademarks.

This document is written in English but may be translated into multiple languages for reference. Only the English version of this document is the final and determinative format released by Diodes Incorporated.

LIFE SUPPORT

Diodes Incorporated products are specifically not authorized for use as critical components in life support devices or systems without the express written approval of the Chief Executive Officer of Diodes Incorporated. As used herein:

- A. Life support devices or systems are devices or systems which:
 - 1. are intended to implant into the body, or
 - 2. support or sustain life and whose failure to perform when properly used in accordance with instructions for use provided in the labeling can be reasonably expected to result in significant injury to the user.
- B. A critical component is any component in a life support device or system whose failure to perform can be reasonably expected to cause the failure of the life support device or to affect its safety or effectiveness.



Customers represent that they have all necessary expertise in the safety and regulatory ramifications of their life support devices or systems, and acknowledge and agree that they are solely responsible for all legal, regulatory and safety-related requirements concerning their products and any use of Diodes Incorporated products in such safety-critical, life support devices or systems, notwithstanding any devices- or systems-related information or support that may be provided by Diodes Incorporated. Further, Customers must fully indemnify Diodes Incorporated and its representatives against any damages arising out of the use of Diodes Incorporated products in such safety-critical, life support devices or systems.

Copyright © 2018, Diodes Incorporated

www.diodes.com

Looking for pricing, stock, or lifecycle information?

Click below to explore more details on WIN SOURCE:

-  [View AS358AP-E1 on WIN SOURCE](#)
-  [Diodes Incorporated Information](#)

Optimize Your Supply Chain with WIN SOURCE Solutions

-  Global Sourcing Solution
-  Obsolete Management
-  Cost Control Management
-  Shortage Management
-  Alternative Solution
-  Excess Inventory Management