

DATA SHEET

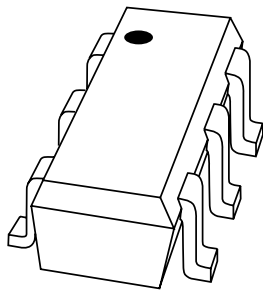

PUMF12

**PNP general purpose transistor;
NPN resistor-equipped transistor**

Product specification

2002 Nov 07

PNP general purpose transistor; NPN resistor-equipped transistor

PUMF12

FEATURES

- General purpose transistor and resistor equipped transistor in one package
- 100 mA collector current
- 50 V collector-emitter voltage
- 300 mW total power dissipation
- SOT363 package; replaces two SOT323 (SC-70) packaged devices on same PCB area
- Reduced pick and place costs.

APPLICATIONS

- Power management switch for portable equipment, e.g. cellular phone and CD player
- Switch for regulator.

DESCRIPTION

PNP general purpose transistor and an NPN resistor-equipped transistor in a SOT363 (SC-88) plastic package.

MARKING

TYPE NUMBER	MARKING CODE ⁽¹⁾
PUMF12	R2*

Note

1. * = p: Made in Hong Kong.
* = t: Made in Malaysia.

QUICK REFERENCE DATA

SYMBOL	PARAMETER	MAX.	UNIT
TR1 (PNP)			
V_{CEO}	collector-emitter voltage	-50	V
I_C	collector current (DC)	-100	mA
I_{CM}	peak collector current	-200	mA
TR2 (NPN)			
V_{CEO}	collector-emitter voltage	50	V
I_O	output current (DC)	100	mA
R1	bias resistor	22	k Ω
R2	bias resistor	47	k Ω

PINNING

PIN	DESCRIPTION
1, 4	emitter TR1; TR2
2, 5	base TR1; TR2
6, 3	collector TR1; TR2

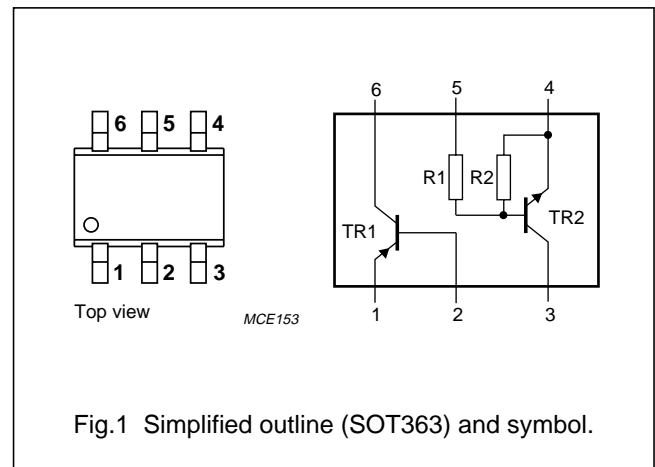

PNP general purpose transistor;
NPN resistor-equipped transistor

PUMF12

LIMITING VALUES

In accordance with the Absolute Maximum Rating System (IEC 60134).

SYMBOL	PARAMETER	CONDITIONS	MIN.	MAX.	UNIT
Per transistor					
P _{tot}	total power dissipation	T _{amb} ≤ 25 °C; note 1	–	200	mW
T _{stg}	storage temperature range		–65	+150	°C
T _j	junction temperature		–	150	°C
T _{amb}	operating ambient temperature		–65	+150	°C
TR1 (PNP)					
V _{CBO}	collector-base voltage	open emitter	–	–50	V
V _{CEO}	collector-emitter voltage	open base	–	–40	V
V _{EBO}	emitter-base voltage	open collector	–	–5	V
I _C	collector current (DC)		–	–100	mA
I _{CM}	peak collector current		–	–200	mA
TR2 (NPN)					
V _{CBO}	collector-base voltage	open emitter	–	50	V
V _{CEO}	collector-emitter voltage	open base	–	50	V
V _{EBO}	emitter-base voltage	open collector	–	10	V
V _i	input voltage				
	positive		–	+40	V
	negative		–	–10	V
I _o	output current (DC)		–	100	mA
I _{CM}	peak collector current		–	100	mA
Per device					
P _{tot}	total power dissipation	T _{amb} ≤ 25 °C; note 1	–	300	mW

Note

1. Device mounted on an FR4 printed-circuit board.

THERMAL CHARACTERISTICS

SYMBOL	PARAMETER	CONDITIONS	VALUE	UNIT
R _{th j-a}	thermal resistance from junction to ambient	note 1	416	K/W

Note

1. Device mounted on an FR4 printed-circuit board.

PNP general purpose transistor;
NPN resistor-equipped transistor

PUMF12

CHARACTERISTICS

T_{amb} = 25 °C unless otherwise specified.

SYMBOL	PARAMETER	CONDITIONS	MIN.	TYP.	MAX.	UNIT
TR1 (PNP)						
I _{CBO}	collector cut-off current	V _{CB} = -30 V; I _E = 0	-	-	-100	nA
		V _{CB} = -30 V; I _E = 0; T _j = 150 °C	-	-	-10	μA
I _{EBO}	emitter cut-off current	V _{EB} = -4 V; I _C = 0	-	-	-100	nA
V _{CEsat}	saturation voltage	I _C = -50 mA; I _B = -5 mA; note 1	-	-	-200	mV
h _{FE}	DC current gain	V _{CE} = -6 V; I _C = -1 mA	120	-	-	
C _c	collector capacitance	V _{CB} = -12 V; I _E = i _e = 0; f = 1 MHz	-	-	2.2	pF
f _T	transition frequency	V _{CE} = -12 V; I _C = -2 mA; f = 100 MHz	100	-	-	MHz
TR2 (NPN)						
I _{CBO}	collector-base cut-off current	V _{CB} = 50 V; I _E = 0	-	-	100	nA
I _{CEO}	collector-emitter cut-off current	V _{CE} = 30 V; I _B = 0	-	-	1	μA
		V _{CE} = 30 V; I _B = 0; T _j = 150 °C	-	-	50	μA
I _{EBO}	emitter-base cut-off current	V _{EB} = 5 V; I _C = 0	-	-	120	μA
h _{FE}	DC current gain	V _{CE} = 5 V; I _C = 5 mA	80	-	-	
V _{CEsat}	saturation voltage	I _C = 10 mA; I _B = 0.5 mA	-	-	150	mV
V _{i(off)}	input off voltage	V _{CE} = 5 V; I _C = 100 μA	-	0.9	0.5	V
V _{i(on)}	input on voltage	V _{CE} = 0.3 V; I _C = 2 mA	2	1.1	-	V
R1	input resistor		15.4	22	28.6	kΩ
$\frac{R2}{R1}$	resistor ratio		1.7	2.1	2.6	
C _c	collector capacitance	V _{CB} = 10 V; I _E = i _e = 0; f = 1 MHz	-	-	2.5	pF

Note

1. Device mounted on an FR4 printed-circuit board.

APPLICATION INFORMATION

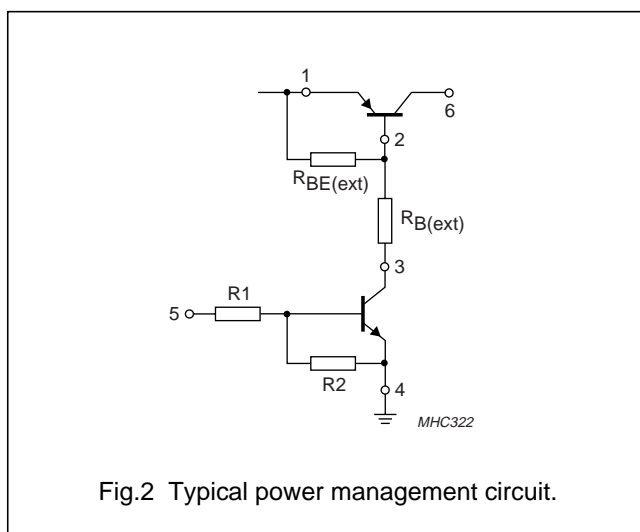

Fig.2 Typical power management circuit.

PNP general purpose transistor;
NPN resistor-equipped transistor

PUMF12

PACKAGE OUTLINE

Plastic surface mounted package; 6 leads

SOT363

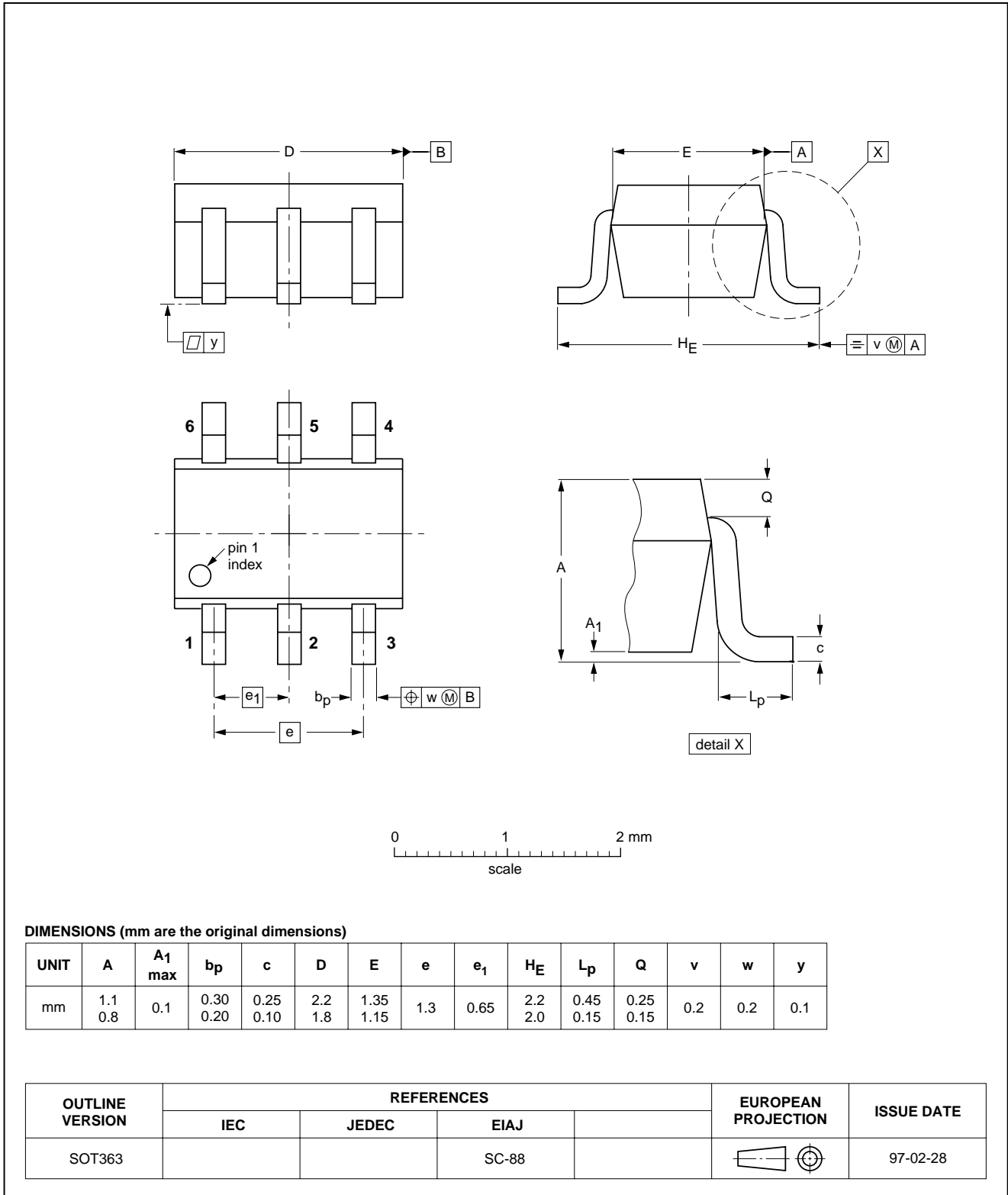

PNP general purpose transistor;
NPN resistor-equipped transistor

PUMF12

DATA SHEET STATUS

LEVEL	DATA SHEET STATUS ⁽¹⁾	PRODUCT STATUS ⁽²⁾⁽³⁾	DEFINITION
I	Objective data	Development	This data sheet contains data from the objective specification for product development. Philips Semiconductors reserves the right to change the specification in any manner without notice.
II	Preliminary data	Qualification	This data sheet contains data from the preliminary specification. Supplementary data will be published at a later date. Philips Semiconductors reserves the right to change the specification without notice, in order to improve the design and supply the best possible product.
III	Product data	Production	This data sheet contains data from the product specification. Philips Semiconductors reserves the right to make changes at any time in order to improve the design, manufacturing and supply. Relevant changes will be communicated via a Customer Product/Process Change Notification (CPCN).

Notes

1. Please consult the most recently issued data sheet before initiating or completing a design.
2. The product status of the device(s) described in this data sheet may have changed since this data sheet was published. The latest information is available on the Internet at URL <http://www.semiconductors.philips.com>.
3. For data sheets describing multiple type numbers, the highest-level product status determines the data sheet status.

DEFINITIONS

Short-form specification — The data in a short-form specification is extracted from a full data sheet with the same type number and title. For detailed information see the relevant data sheet or data handbook.

Limiting values definition — Limiting values given are in accordance with the Absolute Maximum Rating System (IEC 60134). Stress above one or more of the limiting values may cause permanent damage to the device. These are stress ratings only and operation of the device at these or at any other conditions above those given in the Characteristics sections of the specification is not implied. Exposure to limiting values for extended periods may affect device reliability.

Application information — Applications that are described herein for any of these products are for illustrative purposes only. Philips Semiconductors make no representation or warranty that such applications will be suitable for the specified use without further testing or modification.

DISCLAIMERS

Life support applications — These products are not designed for use in life support appliances, devices, or systems where malfunction of these products can reasonably be expected to result in personal injury. Philips Semiconductors customers using or selling these products for use in such applications do so at their own risk and agree to fully indemnify Philips Semiconductors for any damages resulting from such application.

Right to make changes — Philips Semiconductors reserves the right to make changes in the products - including circuits, standard cells, and/or software - described or contained herein in order to improve design and/or performance. When the product is in full production (status 'Production'), relevant changes will be communicated via a Customer Product/Process Change Notification (CPCN). Philips Semiconductors assumes no responsibility or liability for the use of any of these products, conveys no licence or title under any patent, copyright, or mask work right to these products, and makes no representations or warranties that these products are free from patent, copyright, or mask work right infringement, unless otherwise specified.

PNP general purpose transistor;
NPN resistor-equipped transistor

PUMF12

NOTES

Philips Semiconductors – a worldwide company

Contact information

For additional information please visit <http://www.semiconductors.philips.com>. Fax: +31 40 27 24825

For sales offices addresses send e-mail to: sales.addresses@www.semiconductors.philips.com.

© Koninklijke Philips Electronics N.V. 2002

SCA74

All rights are reserved. Reproduction in whole or in part is prohibited without the prior written consent of the copyright owner.

The information presented in this document does not form part of any quotation or contract, is believed to be accurate and reliable and may be changed without notice. No liability will be accepted by the publisher for any consequence of its use. Publication thereof does not convey nor imply any license under patent- or other industrial or intellectual property rights.

Printed in The Netherlands

613514/01/pp8

Date of release: 2002 Nov 07

Document order number: 9397 750 10311

Let's make things better.

**Philips
Semiconductors**



PHILIPS

Looking for pricing, stock, or lifecycle information?

Click below to explore more details on WIN SOURCE:

-  [View PUMF12,115 on WIN SOURCE](#)
-  [Nexperia USA Inc. Information](#)

Optimize Your Supply Chain with WIN SOURCE Solutions

-  Global Sourcing Solution
-  Obsolete Management
-  Cost Control Management
-  Shortage Management
-  Alternative Solution
-  Excess Inventory Management