



**THE DATASHEET OF
LTC1044ACN8#PBF**



FEATURES

- 1.5V to 12V Operating Supply Voltage Range
- 13V Absolute Maximum Rating
- 200 μ A Maximum No Load Supply Current at 5V
- Boost Pin (Pin 1) for Higher Switching Frequency
- 97% Minimum Open Circuit Voltage Conversion Efficiency
- 95% Minimum Power Conversion Efficiency
- $I_S = 1.5\mu$ A with 5V Supply When OSC Pin = 0V or V^+
- High Voltage Upgrade to ICL7660/LTC1044

APPLICATIONS

- Conversion of 10V to ± 10 V Supplies
- Conversion of 5V to ± 5 V Supplies
- Precise Voltage Division: $V_{OUT} = V_{IN}/2 \pm 20$ ppm
- Voltage Multiplication: $V_{OUT} = \pm nV_{IN}$
- Supply Splitter: $V_{OUT} = \pm V_S/2$
- Automotive Applications
- Battery Systems with 9V Wall Adapters/Chargers

DESCRIPTION

The **LTC[®]1044A** is a monolithic CMOS switched-capacitor voltage converter. It plugs in for ICL7660/LTC1044 in applications where higher input voltage (up to 12V) is needed. The LTC1044A provides several conversion functions without using inductors. The input voltage can be inverted ($V_{OUT} = -V_{IN}$), doubled ($V_{OUT} = 2V_{IN}$), divided ($V_{OUT} = V_{IN}/2$) or multiplied ($V_{OUT} = \pm nV_{IN}$).

To optimize performance in specific applications, a boost function is available to raise the internal oscillator frequency by a factor of seven. Smaller external capacitors can be used in higher frequency operation to save board space. The internal oscillator can also be disabled to save power. The supply current drops to 1.5 μ A at 5V input when the OSC pin is tied to GND or V^+ .

LT, LT, LTC, LTM, Linear Technology and the Linear logo are registered trademarks of Linear Technology Corporation. All other trademarks are the property of their respective owners.

TYPICAL APPLICATION

Generating -10V from 10V

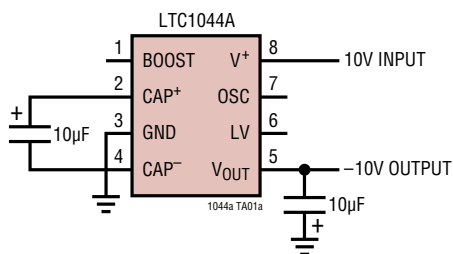

Output Voltage vs Load Current, $V^+ = 10$ V

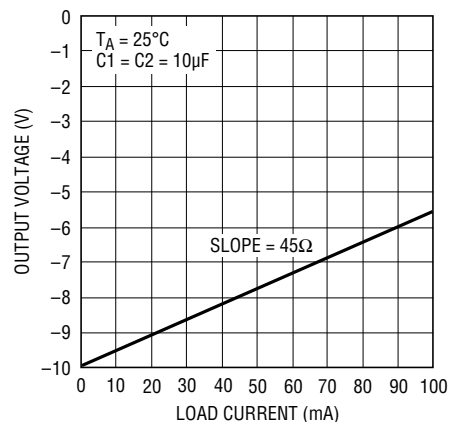

1044a TA01b

LTC1044A

ABSOLUTE MAXIMUM RATINGS

(Note 1)

Supply Voltage 13V
 Input Voltage on Pins 1, 6 and 7
 (Note 2)..... $-0.3V < V_{IN} < V^+ + 0.3V$
 Current into Pin 6..... 20 μ A
 Output Short-Circuit Duration
 $V^+ \leq 6.5V$ Continuous

Operating Temperature Range
 LTC1044AC 0°C to 70°C
 LTC1044AI -40°C to 85°C
 Storage Temperature Range..... -65°C to 150°C
 Lead Temperature (Soldering, 10 sec) 300°C

PIN CONFIGURATION

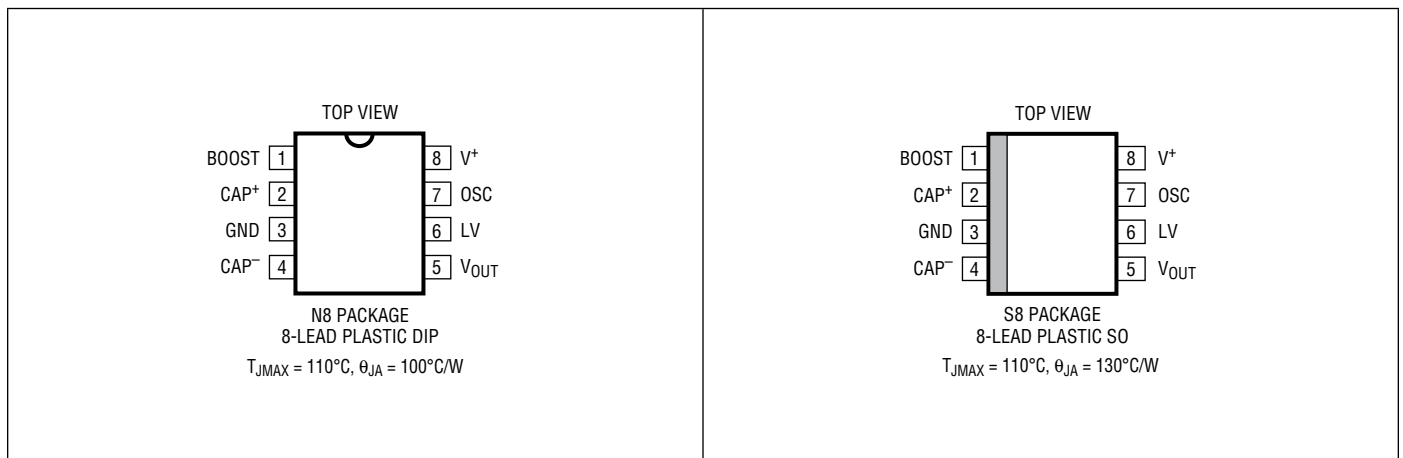

Consult factory for military grade parts

ORDER INFORMATION

LEAD FREE FINISH	TAPE AND REEL	PART MARKING	PACKAGE DESCRIPTION	TEMPERATURE RANGE
LTC1044ACN8#PBF	LTC1044ACN8#TRPBF	LTC1044 ACN8	8-Lead Plastic DIP	0°C to 70°C
LTC1044AIN8#PBF	LTC1044AIN8#TRPBF	LTC1044 AIN8	8-Lead Plastic DIP	-40°C to 85°C
LTC1044ACS8#PBF	LTC1044ACS8#TRPBF	1044A	8-Lead Plastic SO	0°C to 70°C
LTC1044AIS8#PBF	LTC1044AIS8#TRPBF	1044AI	8-Lead Plastic SO	-40°C to 85°C

Consult LTC Marketing for parts specified with wider operating temperature ranges.

Consult LTC Marketing for information on nonstandard lead based finish parts.

For more information on lead free part marking, go to: <http://www.linear.com/leadfree/>

For more information on tape and reel specifications, go to: <http://www.linear.com/tapeandreeel/>

ELECTRICAL CHARACTERISTICS

The ● denotes the specifications which apply over the full operating temperature range, otherwise specifications are at $T_A = 25^\circ\text{C}$. $V^+ = 5\text{V}$, $C_{\text{OSC}} = 0\text{pF}$, unless otherwise noted.

SYMBOL	PARAMETER	CONDITIONS	LTC1044AC			LTC1044AI			UNITS
			MIN	TYP	MAX	MIN	TYP	MAX	
I_S	Supply Current	$R_L = \infty$, Pins 1 and 7, No Connection $R_L = \infty$, Pins 1 and 7, No Connection, $V^+ = 3\text{V}$		60 15	200	60 15	200	μA μA	
	Minimum Supply Voltage	$R_L = 10\text{k}$	●	1.5		1.5		V	
	Maximum Supply Voltage	$R_L = 10\text{k}$	●		12		12	V	
R_{OUT}	Output Resistance	$I_L = 20\text{mA}$, $f_{\text{OSC}} = 5\text{kHz}$			100		100	Ω	
		$V^+ = 2\text{V}$, $I_L = 3\text{mA}$, $f_{\text{OSC}} = 1\text{kHz}$	●		120		130	Ω	
			●		310		325	Ω	
f_{OSC}	Oscillator Frequency	$V^+ = 5\text{V}$, (Note 3)	●	5		5		kHz	
		$V^+ = 2\text{V}$	●	1		1		kHz	
P_{EFF}	Power Efficiency	$R_L = 5\text{k}$, $f_{\text{OSC}} = 5\text{kHz}$		95	98	95	98	%	
	Voltage Conversion Efficiency	$R_L = \infty$		97	99.9	97	99.9	%	
	Oscillator Sink or Source Current	$V_{\text{OSC}} = 0\text{V}$ or V^+							
		Pin 1 (BOOST) = 0V Pin 1 (BOOST) = V^+	● ●		3 20		3 20	μA μA	

Note 1: Stresses beyond those listed under Absolute Maximum Ratings may cause permanent damage to the device. Exposure to any Absolute Maximum Rating condition for extended periods may affect device reliability and lifetime.

Note 2: Connecting any input terminal to voltages greater than V^+ or less than ground may cause destructive latchup. It is recommended that no

inputs from sources operating from external supplies be applied prior to power-up of the LTC1044A.

Note 3: f_{OSC} is tested with $C_{\text{OSC}} = 100\text{pF}$ to minimize the effects of test fixture capacitance loading. The 0pF frequency is correlated to this 100pF test point, and is intended to simulate the capacitance at pin 7 when the device is plugged into a test socket and no external capacitor is used.

TYPICAL PERFORMANCE CHARACTERISTICS

Operating Voltage Range vs Temperature

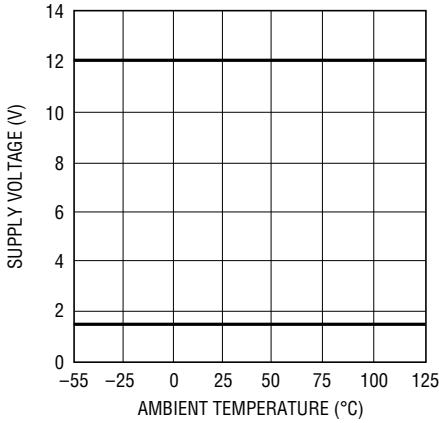

1044a G01

Power Efficiency vs Oscillator Frequency, $V^+ = 5V$

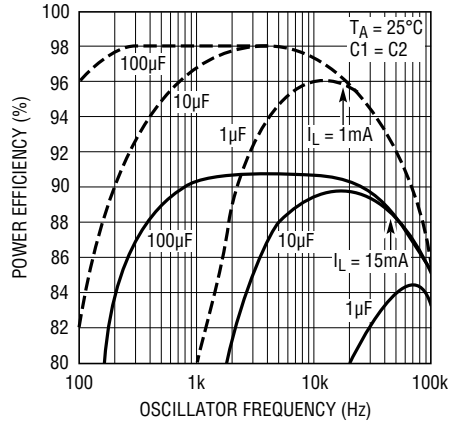

1044a G02

Power Efficiency vs Oscillator Frequency, $V^+ = 10V$

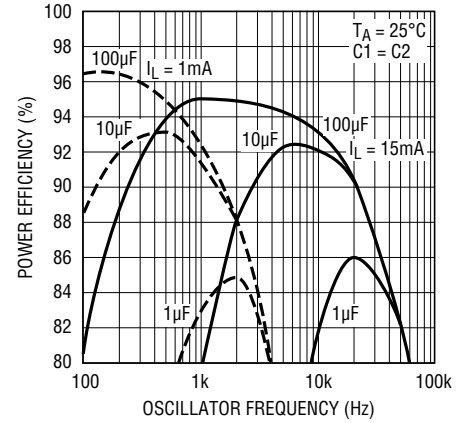

1044a G03

Output Resistance vs Oscillator Frequency, $V^+ = 5V$

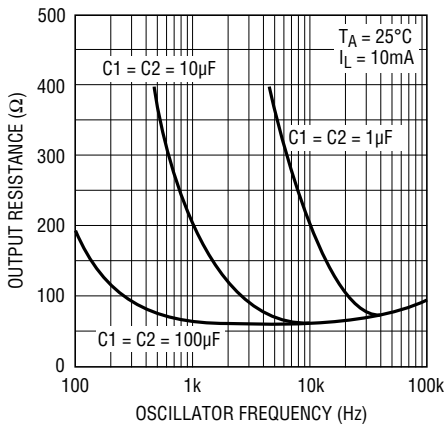

1044a G04

Output Resistance vs Oscillator Frequency, $V^+ = 10V$

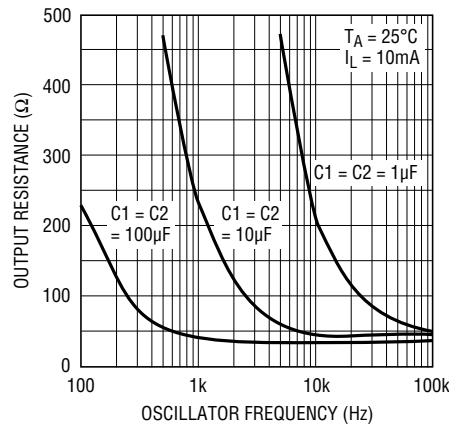

1044a G05

Power Conversion Efficiency vs Load Current, $V^+ = 2V$

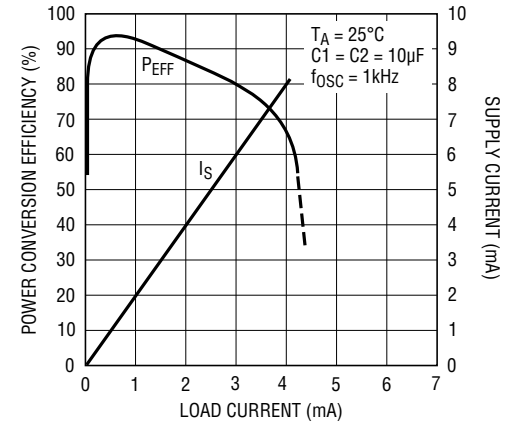

1044a G06

Power Conversion Efficiency vs Load Current, $V^+ = 5V$

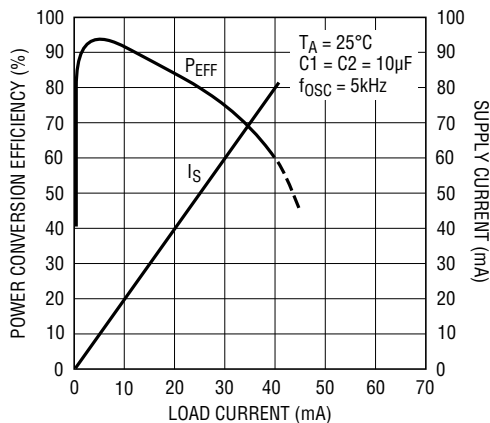

1044a G07

Power Conversion Efficiency vs Load Current, $V^+ = 10V$

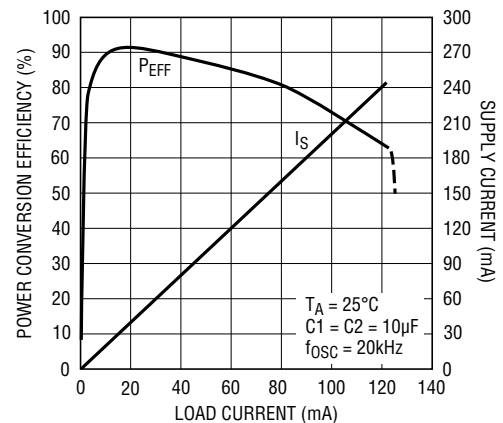

1044a G08

TYPICAL PERFORMANCE CHARACTERISTICS

Output Resistance vs Supply Voltage

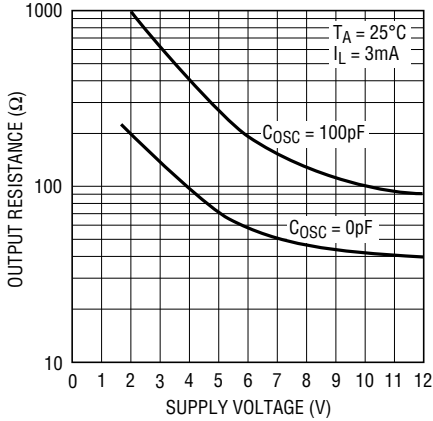

1044a G09

Output Voltage vs Load Current, $V^+ = 2V$

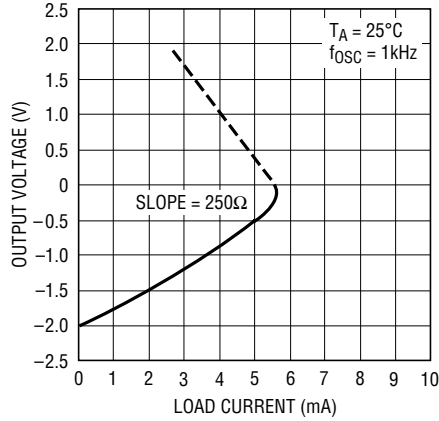

1044a G10

Output Voltage vs Load Current, $V^+ = 5V$

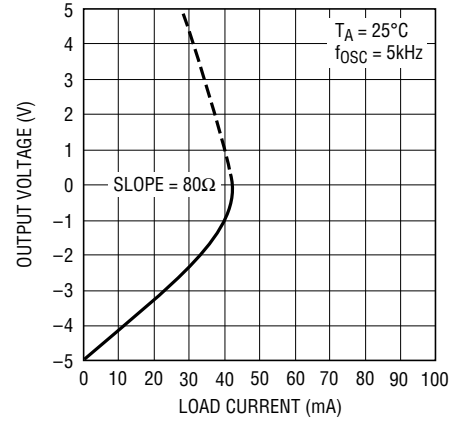

1044a G11

Output Voltage vs Load Current, $V^+ = 10V$

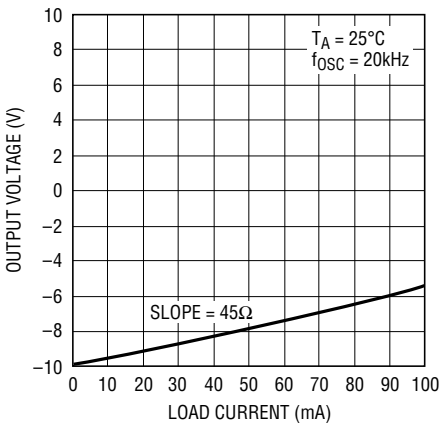

1044a G12

Output Resistance vs Temperature

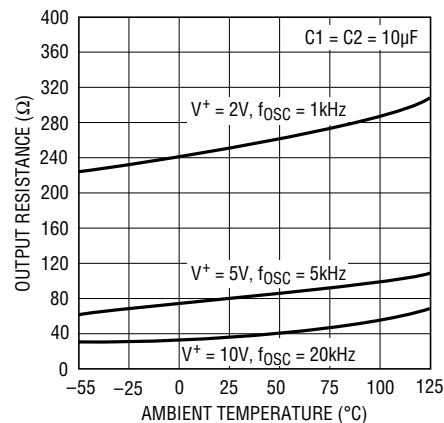

1044a G13

Oscillator Frequency as a Function of C_{osc} , $V^+ = 5V$

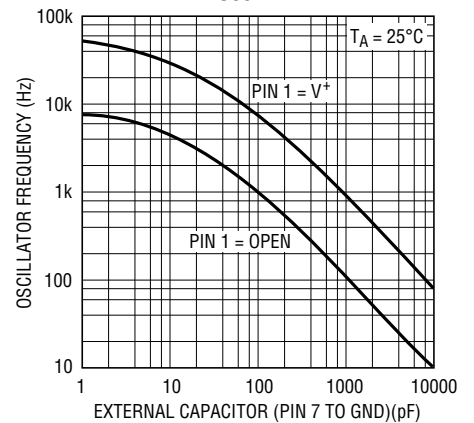

1044a G14

Oscillator Frequency as a Function of C_{osc} , $V^+ = 10V$

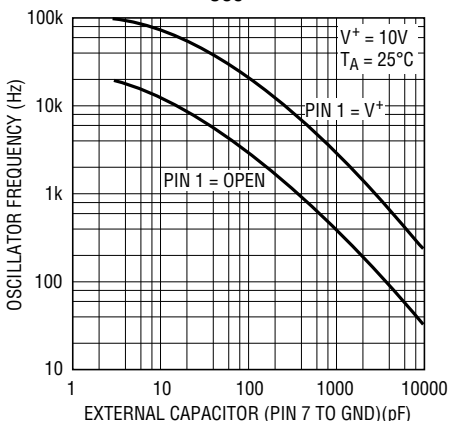

1044a G15

Oscillator Frequency vs Supply Voltage

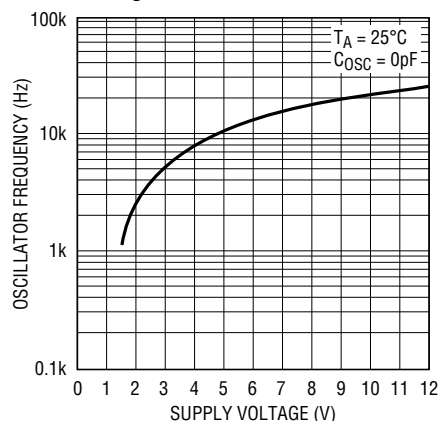

1044a G16

Oscillator Frequency vs Temperature

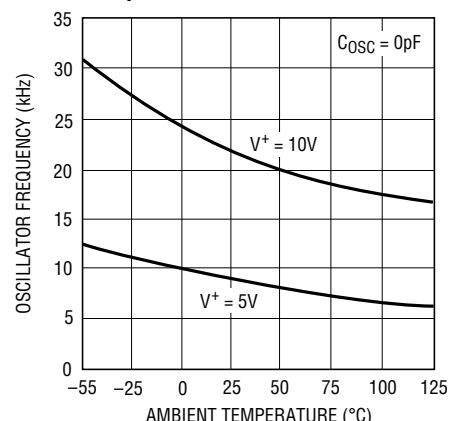

1044a G17

TEST CIRCUIT

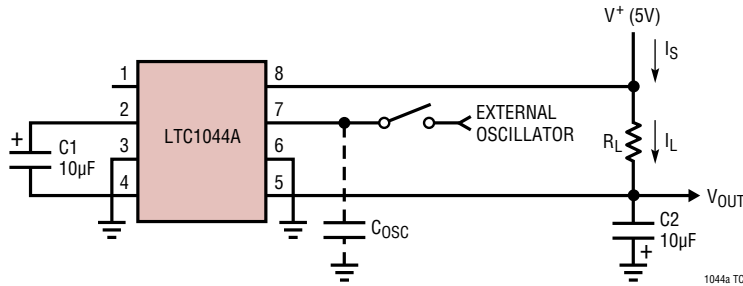

APPLICATIONS INFORMATION

Theory of Operation

To understand the theory of operation of the LTC1044A, a review of a basic switched-capacitor building block is helpful.

In Figure 1, when the switch is in the left position, capacitor C1 will charge to voltage V1. The total charge on C1 will be $q_1 = C_1V_1$. The switch then moves to the right, discharging C1 to voltage V2. After this discharge time, the charge on C1 is $q_2 = C_1V_2$. Note that charge has been transferred from the source, V1, to the output, V2. The amount of charge transferred is:

$$\Delta q = q_1 - q_2 = C_1(V_1 - V_2)$$

If the switch is cycled f times per second, the charge transfer per unit time (i.e., current) is:

$$I = f \cdot \Delta q = f \cdot C_1(V_1 - V_2)$$

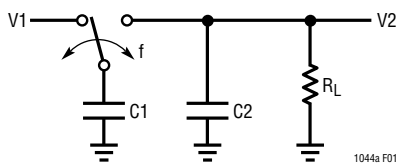

Figure 1. Switched-Capacitor Building Block

Rewriting in terms of voltage and impedance equivalence,

$$I = \frac{V_1 - V_2}{\frac{1}{f \cdot C_1}} = \frac{V_1 - V_2}{R_{EQUIV}}$$

A new variable, R_{EQUIV} , has been defined such that $R_{EQUIV} = 1/(f \cdot C_1)$. Thus, the equivalent circuit for the switched-capacitor network is as shown in Figure 2.

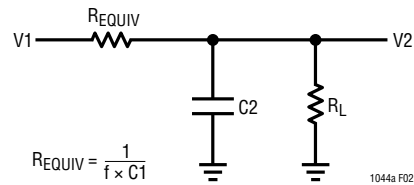

Figure 2. Switched-Capacitor Equivalent Circuit

Examination of Figure 3 shows that the LTC1044A has the same switching action as the basic switched-capacitor building block. With the addition of finite switch-on resistance and output voltage ripple, the simple theory although not exact, provides an intuitive feel for how the device works.

For example, if you examine power conversion efficiency as a function of frequency (see typical curve), this simple theory will explain how the LTC1044A behaves. The loss, and hence the efficiency, is set by the output impedance. As frequency is decreased, the output impedance will eventually be dominated by the $1/(f \cdot C_1)$ term, and power efficiency will drop. The typical curves for Power Efficiency vs Frequency show this effect for various capacitor values.

Note also that power efficiency decreases as frequency goes up. This is caused by internal switching losses which occur due to some finite charge being lost on each switching cycle. This charge loss per unit cycle, when multiplied by the switching frequency, becomes a current loss. At high frequency this loss becomes significant and the power efficiency starts to decrease.

APPLICATIONS INFORMATION

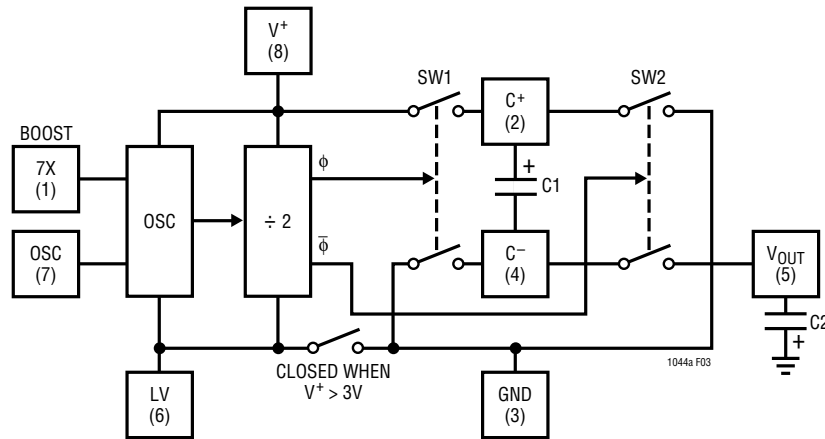

Figure 3. LTC1044A Switched-Capacitor Voltage Converter Block Diagram

LV (Pin 6)

The internal logic of the LTC1044A runs between V^+ and LV (pin 6). For V^+ greater than or equal to 3V, an internal switch shorts LV to GND (pin 3). For V^+ less than 3V, the LV pin should be tied to GND. For V^+ greater than or equal to 3V, the LV pin can be tied to GND or left floating.

OSC (Pin 7) and Boost (Pin 1)

The switching frequency can be raised, lowered, or driven from an external source. Figure 4 shows a functional diagram of the oscillator circuit.

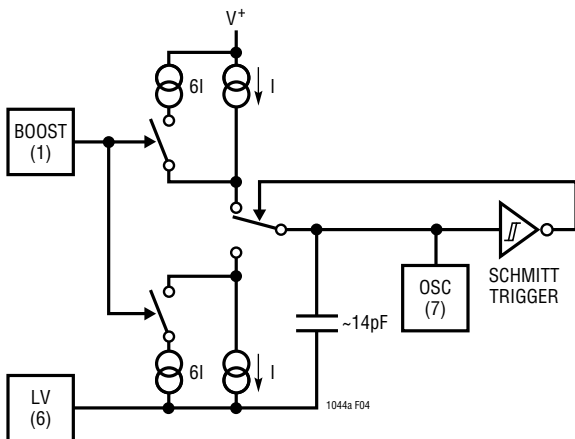

Figure 4. Oscillator

By connecting the boost pin (pin 1) to V^+ , the charge and discharge current is increased and hence, the frequency is increased by approximately seven times. Increasing the frequency will decrease output impedance and ripple for higher load currents.

Loading pin 7 with more capacitance will lower the frequency. Using the boost (pin 1) in conjunction with external capacitance on pin 7 allows user selection of the frequency over a wide range.

Driving the LTC1044A from an external frequency source can be easily achieved by driving pin 7 and leaving the boost pin open as shown in Figure 5. The output current from pin 7 is small (typically 0.5 μ A) so a logic gate is capable of driving this current. The choice of using a CMOS logic gate is best because it can operate over a wide supply voltage range (3V to 15V) and has enough voltage swing to drive the internal Schmitt trigger shown in Figure 4. For 5V applications, a TTL logic gate can be used by simply adding an external pull-up resistor (see Figure 5).

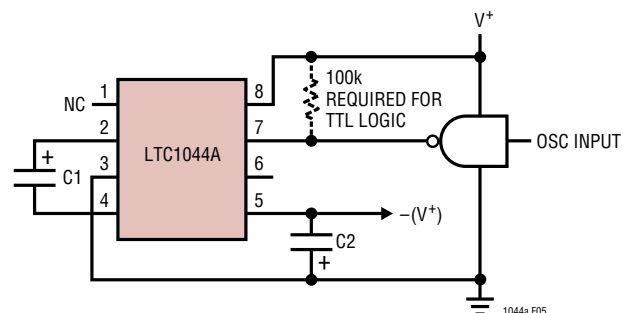

Figure 5. External Clocking

APPLICATIONS INFORMATION

Capacitor Selection

External capacitors C1 and C2 are not critical. Matching is not required, nor do they have to be high quality or tight tolerance. Aluminum or tantalum electrolytics are excellent choices with cost and size being the only consideration.

Negative Voltage Converter

Figure 6 shows a typical connection which will provide a negative supply from an available positive supply. This circuit operates over full temperature and power supply ranges *without* the need of any external diodes. The LV pin (pin 6) is shown grounded, but for $V^+ \geq 3V$ it may be *floated*, since LV is internally switched to ground (pin 3) for $V^+ \geq 3V$.

The output voltage (pin 5) characteristics of the circuit are those of a nearly ideal voltage source in series with an 80Ω resistor. The 80Ω output impedance is composed of two terms:

1. The equivalent switched-capacitor resistance (see Theory of Operation).
2. A term related to the on-resistance of the MOS switches.

At an oscillator frequency of 10kHz and $C1 = 10\mu F$, the first term is:

$$R_{EQUIV} = \frac{1}{(f_{OSC}/2) \cdot C1}$$

$$= \frac{1}{5 \cdot 10^3 \cdot 10 \cdot 10^{-6}} = 20\Omega$$

Notice that the above equation for R_{EQUIV} is *not* a capacitive reactance equation ($X_C = 1/\omega C$) and does not contain a 2π term.

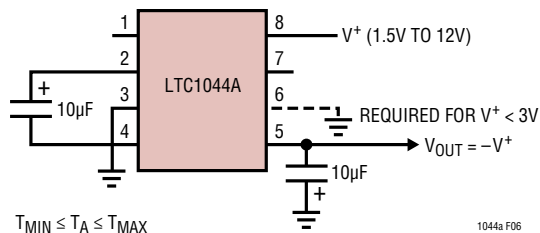

Figure 6. Negative Voltage Converter

The exact expression for output resistance is extremely complex, but the dominant effect of the capacitor is clearly shown on the typical curves of Output Resistance and Power Efficiency vs Frequency. For $C1 = C2 = 10\mu F$, the output impedance goes from 60Ω at $f_{OSC} = 10kHz$ to 200Ω at $f_{OSC} = 1kHz$. As the $1/(f \cdot C)$ term becomes large compared to the switch-on resistance term, the output resistance is determined by $1/(f \cdot C)$ only.

Voltage Doubling

Figure 7 shows a two-diode capacitive voltage doubler. With a 5V input, the output is 9.93V with no load and 9.13V with a 10mA load. With a 10V input, the output is 19.93V with no load and 19.28V with a 10mA load.

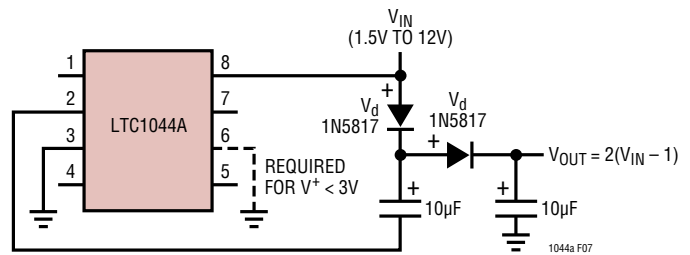

Figure 7. Voltage Doubler

Ultra-Precision Voltage Divider

An ultra-precision voltage divider is shown in Figure 8. To achieve the 0.002% accuracy indicated, the load current should be kept below 100nA. However, with a slight loss in accuracy the load current can be increased.

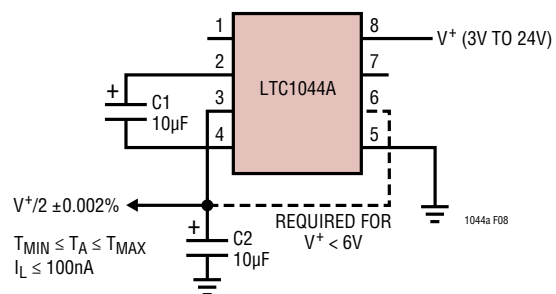

Figure 8. Ultra-Precision Voltage Divider

APPLICATIONS INFORMATION

Battery Splitter

A common need in many systems is to obtain (+) and (-) supplies from a single battery or single power supply system. Where current requirements are small, the circuit shown in Figure 9 is a simple solution. It provides symmetrical \pm output voltages, both equal to one half input voltage. The output voltages are both referenced to pin 3 (output common). If the input voltage between pin 8 and pin 5 is less than 6V, pin 6 should also be connected to pin 3 as shown by the dashed line.

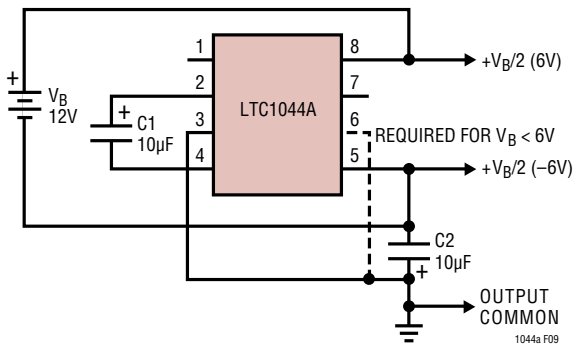

Figure 9. Battery Splitter

Paralleling for Lower Output Resistance

Additional flexibility of the LTC1044A is shown in Figures 10 and 11.

Figure 10 shows two LTC1044As connected in parallel to provide a lower effective output resistance. If, however, the output resistance is dominated by $1/(f \cdot C1)$, increasing the capacitor size (C1) or increasing the frequency will be of more benefit than the paralleling circuit shown.

Figure 11 makes use of *stacking* two LTC1044As to provide even higher voltages. A negative voltage doubler or tripler can be achieved, depending upon how pin 8 of the second LTC1044A is connected, as shown schematically by the switch. The available output current will be dictated/decreased by the product of the individual power conversion efficiencies and the voltage step-up ratio.

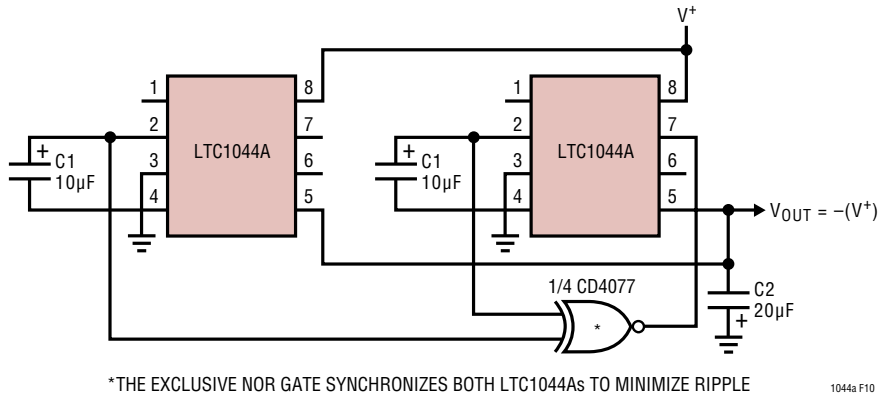

Figure 10. Paralleling for Lower Output Resistance

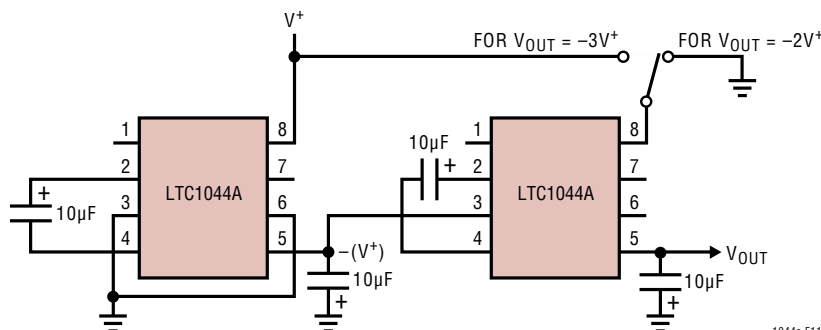
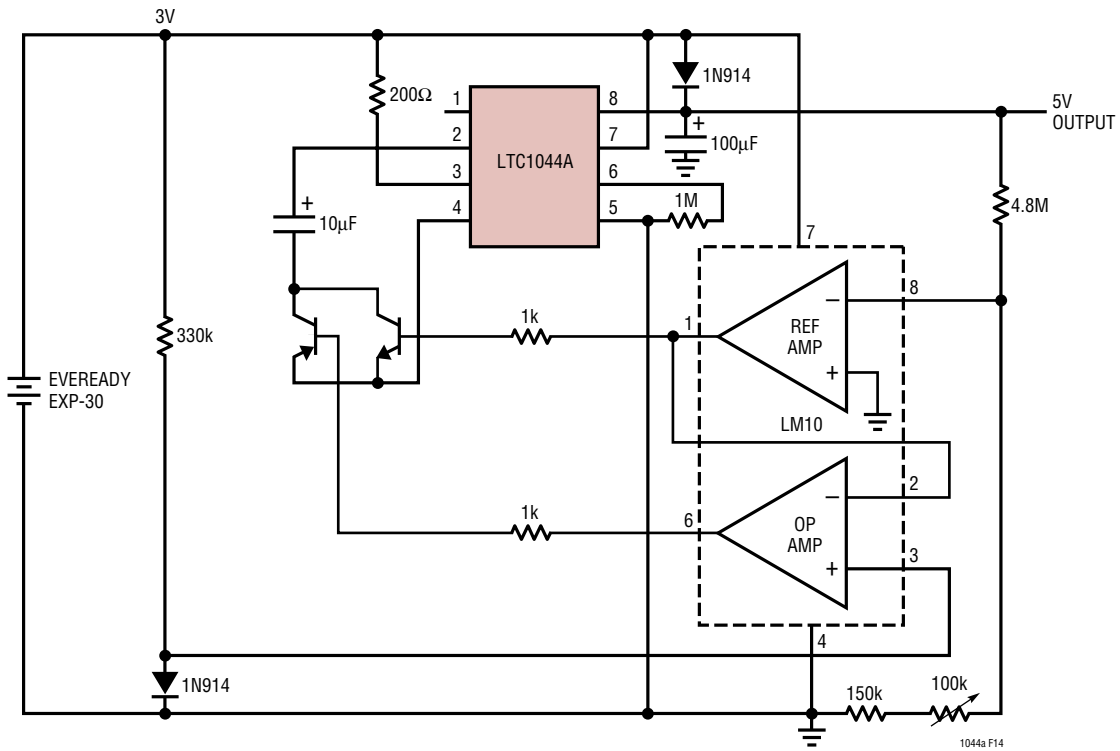

Figure 11. Stacking for Higher Voltage

TYPICAL APPLICATIONS

Regulated Output 3V to 5V Converter



Low Dropout 5V Regulator

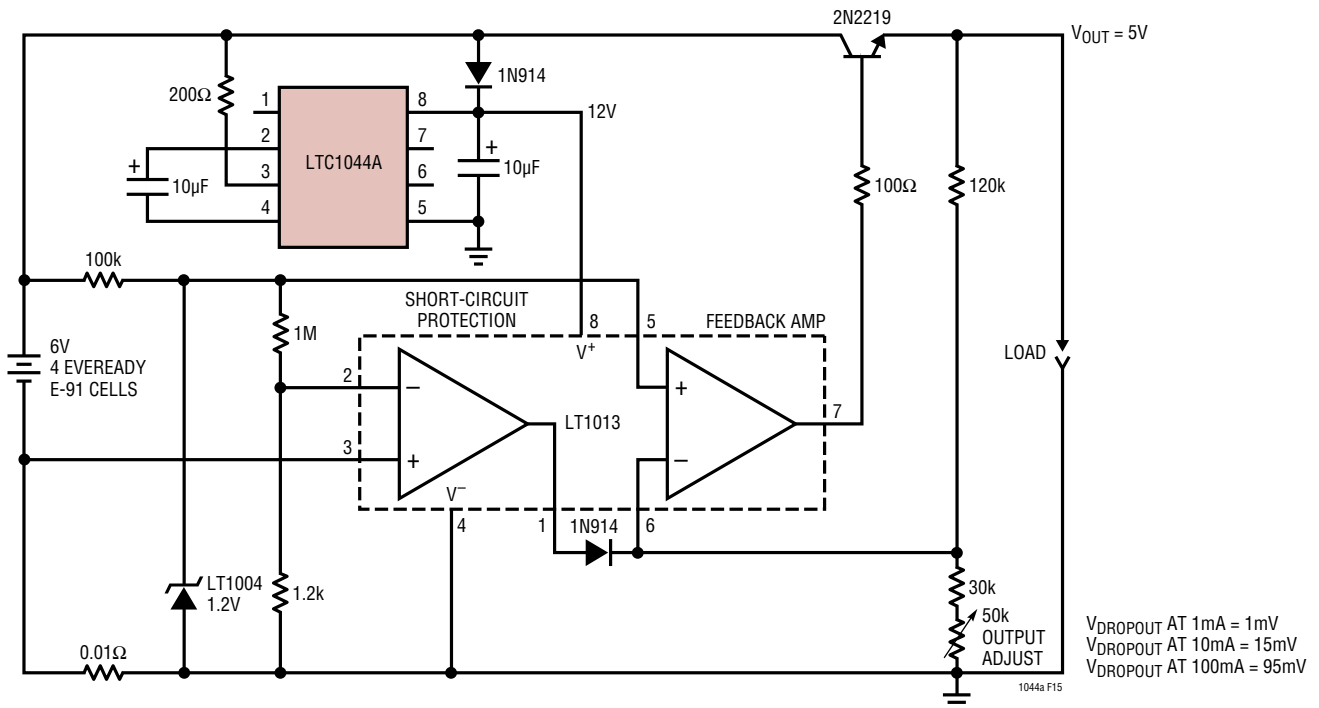

REVISION HISTORY

REV	DATE	DESCRIPTION	PAGE NUMBER
A	4/14	Changed 0.0002% to 0.002% in the Ultra-Precision Voltage Divider section	8

LTC1044A

TYPICAL APPLICATION

Two-Diode Capacitive Voltage Doubler

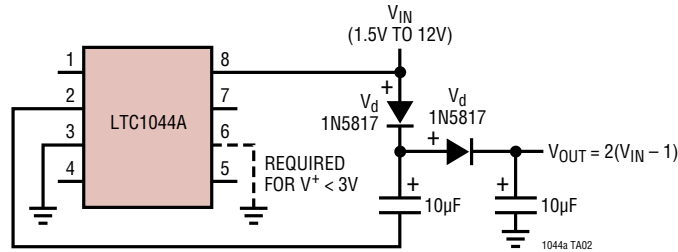

RELATED PARTS

PART NUMBER	DESCRIPTION	COMMENTS
LTC3240-3.3/ LTC3240-2.5	3.3V/2.5V Step-Up/Step-Down Charge Pump DC/DC Converter	V_{IN} : 1.8V to 5.5V, $V_{OUT(MAX)}$ = 3.3V/2.5V, I_Q = 65µA, I_{SD} < 1µA, (2mm × 2mm) DFN Package
LTC3245	Wide V_{IN} Range Low Noise 250mA Buck-Boost Charge Pump	V_{IN} : 2.7V to 38V, $V_{OUT(MAX)}$ = 5V, I_Q = 20µA, I_{SD} = 4µA, 12-Lead MS and (3mm × 4mm) DFN Packages
LTC3255	Wide V_{IN} Range 50mA Buck (Step-Down) Charge Pump	V_{IN} : 4V to 48V, $V_{OUT(MAX)}$ = 12.5V, I_Q = 16µA, 10-Lead MSOP and (3mm × 3mm) DFN Packages

1044afa

Looking for pricing, stock, or lifecycle information?

Click below to explore more details on WIN SOURCE:

 [View LTC1044ACN8#PBF on WIN SOURCE](#)

 [Linear Technology](#) Information

Optimize Your Supply Chain with WIN SOURCE Solutions

-  Global Sourcing Solution
-  Obsolete Management
-  Cost Control Management
-  Shortage Management
-  Alternative Solution
-  Excess Inventory Management