



# THE DATASHEET OF TPS65530ARSLT





## FULLY INTEGRATED 8-CHANNEL DC/DC CONVERTER FOR DIGITAL STILL CAMERAS

### FEATURES

- 8-Channel DC/DC Converter and Low Dropout (LDO)
- Integrated Power MOSFET Switch Except CH8
  - Boost (CH5/7)
  - Buck (CH1/3)
  - Buck-Boost (CH2/4)
  - Invert (CH6)
- Low-Power Suspend Mode (Sleep Mode)
- Power ON/OFF Sequence (CH1/2/3 and CH5/6)
- LED-Back Light Brightness Control (CH7)
- Fixed Switching Frequency (CH1–4: 1.5 MHz, CH5–8: 750 kHz)
- Fixed Max Duty Cycle Internally
- Soft Start
- Undervoltage Lockout (UVLO)
- Protection
  - Thermal Shutdown (TSD)
  - Overvoltage Protection (OVP)
  - Overcurrent Protection (OCP) Except CH8
- Supply Voltage Range: 1.5 V to 5.5 V
- Operating Temperature Range: –25°C to 85°C
- 6 × 6 mm, 0.4-mm Pitch, 48-Pin QFN Package

### APPLICATIONS

- Digital Still Cameras (DSCs)
- Portable Electronics Equipment

### DESCRIPTION/ ORDERING INFORMATION

The TPS65530A is a fully integrated 8-channel switching dc/dc converter, and seven channels have integrated power FET.

CH2/4 are configured for H bridge for buck-boost topology and single inductor supports. These channels achieve higher efficiency in spite of input/output voltage conditions.

CH7 has a brightness control and drives white LED by constant current. Also, CH7 supports overvoltage protection (OVP) for open load.

CH1/2/3 have a power ON/OFF sequence suitable for a digital still camera (DSC) system. CH5/6 have a power ON/OFF sequence, depending on the CCD. Power ON/OFF for CCD block (CH5/6) is selectable by the input voltage level at the SEQ56 pin. CH4 and CH7 have individual ON/OFF sequences.

The TPS65530A high switching frequency is achieved by an integrated power MOSFET switch. It reduces external parts dynamically. Shutdown current consumption is less than 1  $\mu$ A as a typical value.

### ORDERING INFORMATION

T <sub>A</sub>	PACKAGE <sup>(1)(2)</sup>	ORDERABLE PART NUMBER	TOP-SIDE MARKING
–25°C to 85°C	QFN	Reel of 250	TPS65530ARSLT
		Reel of 2500	TPS65530ARSLR
			TPS65530A

(1) Package drawings, thermal data, and symbolization are available at [www.ti.com/packaging](http://www.ti.com/packaging).

(2) For the most current package and ordering information, see the Package Option Addendum at the end of this document, or see the TI website at [www.ti.com](http://www.ti.com).



Please be aware that an important notice concerning availability, standard warranty, and use in critical applications of Texas Instruments semiconductor products and disclaimers thereto appears at the end of this data sheet.

PowerPAD is a trademark of Texas Instruments.



These devices have limited built-in ESD protection. The leads should be shorted together or the device placed in conductive foam during storage or handling to prevent electrostatic damage to the MOS gates.

### CHANNEL CONFIGURATION

CHANNEL	OPERATION MODE	RECTIFY MODE	CONTROL METHOD	OUTPUT VOLTAGE (V)	APPLICATION	MAXIMUM SUPPLY CURRENT (mA)
CH1	Buck SW	Synchronous	Voltage	0.9 to 2.5	Engine core	600
CH2	Buck-boost SW	Synchronous	Average current	2.5 to 3.6	Engine I/O (DSP I/F)	600
CH3	Buck SW	Synchronous	Voltage	0.9 to 2.5	External memory	300
CH4	Buck-boost SW	Synchronous	Average current	2.2 to 3.6	AFE	300
CH5	Boost SW	Nonsynchronous	Peak current	Up to 18	CCD+	50
CH6	Invert SW	Nonsynchronous	Voltage	-10 to -5	CCD-	100
CH7	Boost SW	Nonsynchronous	Voltage	3 to 20	Backlight LED	25
CH8	Boost SW	Synchronous	Voltage	3.3 to 5.5	Motor controller and IC drive supply	-
REF	Low dropout voltage	-	-	2.8	Internal supply for logic	15

QFN PACKAGE  
(TOP VIEW)

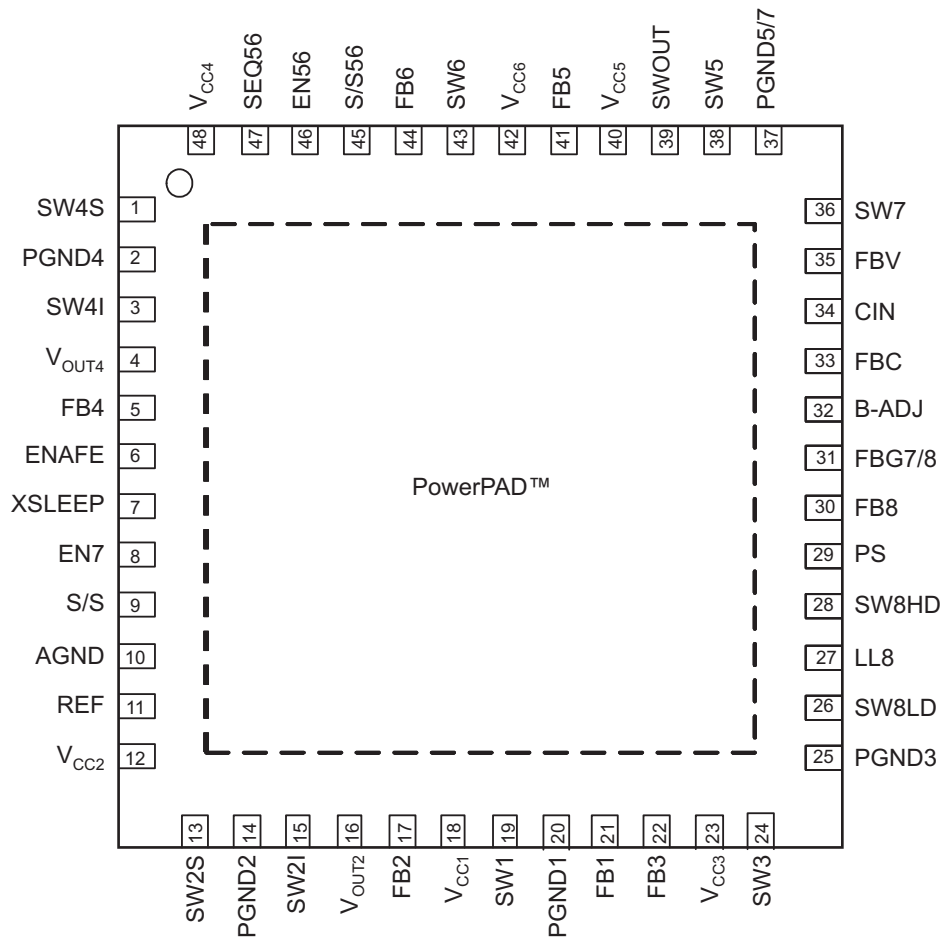

**TERMINAL FUNCTIONS**

TERMINAL		I/O <sup>(1)</sup>	DESCRIPTION
NO.	NAME		
1	SW4S	O	Buck-side terminal of coil for CH4
2	PGND4	G	GND for CH4 low-side FET
3	SW4I	I	Boost-side terminal of coil for CH4
4	V <sub>OUT4</sub>	O	Output of CH4
5	FB4	I	Output voltage feedback for CH4. The external resistors should be connected as close as possible to the terminal.
6	ENAFE	I	Enable for CH4 (L: Disable, H: Enable)
7	XSLEEP	I	Control for sleep mode/normal operation (L: Sleep mode, H: Normal operation)
8	EN7	I	Enable for CH7 (L: Disable, H: Enable)
9	S/S	I/O	Soft-start time adjustment. The time is programmable by an external capacitor (see the Soft Start description).
10	AGND	G	Analog ground
11	REF	O	Output of LDO. From 2.2 $\mu$ F to 4.7 $\mu$ F, capacitor should be connected to AGND.
12	V <sub>CC2</sub>	P	Power supply at CH2 buck-side FET from battery
13	SW2S	O	Buck-side terminal of coil for CH2
14	PGND2	G	GND for CH2 low-side FET
15	SW2I	I	Boost-side terminal of coil for CH2
16	V <sub>OUT2</sub>	O	Output of CH2
17	FB2	O	Output voltage feedback for CH2. The external resistors should be connected as close as possible to the terminal.
18	V <sub>CC1</sub>	P	Power supply at CH1 high-side FET from battery
19	SW1	O	Output of CH1. The terminal should be connected to the external inductor.
20	PGND1	G	GND for CH1 low-side FET
21	FB1	I	Output voltage feedback for CH1. The external resistors should be connected as close as possible to the terminal.
22	FB3	I	Output voltage feedback for CH3. The external resistors should be connected as close as possible to the terminal.
23	V <sub>CC3</sub>	P	Power supply at CH3 high-side FET from battery
24	SW3	O	Output of CH3. The terminal should be connected to the external inductor.
25	PGND3	G	GND for CH3 low-side FET
26	SW8LD	O	Output for CH8 external low-side FET drive. The terminal is connected to the gate of the low-side external FET.
27	LL8	O	Switching output for CH8 at wake mode. The terminal is switched when the output voltage of CH8 is less than 2.5 V.
28	SW8HD	O	Output for CH8 external high-side FET drive. The terminal is connected to the gate of the high-side external FET.
29	PS	I	Power input for IC inside. The terminal should be connected to CH8 output voltage.
30	FB8	I	Output voltage feedback for CH8. The external resistors should be connected as close as possible to the terminal.
31	FBG7/8	I	GND for CH7/8 feedback resistors
32	B-ADJ	I	Brightness adjustment for W-LED
33	FBC	I	Output current feedback for CH7
34	CIN	I	Input current at CH7 load switch
35	FBV	I	Output voltage feedback for CH7. The external resistors should be connected as close as possible to the terminal.
36	SW7	O	Output of CH7. The terminal should be connected to the external inductor.
37	PGND5/7	G	Power GND for CH5/7. The terminal should be connected by power ground layer at PCB via a through hole.
38	SW5	O	Low-side terminal of coil for CH5

(1) I = input, O = output, I/O = input/output, P = power supply, G = GND

**TERMINAL FUNCTIONS (continued)**

TERMINAL		I/O <sup>(1)</sup>	DESCRIPTION
NO.	NAME		
39	SWOUT	O	High-side terminal of coil for CH5
40	V <sub>CC5</sub>	P	Power supply at CH5 high-side FET from battery
41	FB5	I	Output voltage feedback for CH5. The external resistors should be connected as close as possible to the terminal.
42	V <sub>CC6</sub>	P	Power supply at CH6 load switch from battery
43	SW6	O	Output of CH6. The terminal should be connected to the external inductor.
44	FB6	I	Output voltage feedback for CH6. The external resistors should be connected as close as possible to the terminal.
45	S/S56	I/O	Soft-start time adjustment for CH5/6. The time is programmable by external capacitor (see the Soft Start description).
46	EN56	I	Enable for CH5/6 (L: Disable, H: Enable)
47	SEQ56	I	Sequence select for CH5/6 (see the Power ON/OFF Sequence description)
48	V <sub>CC4</sub>	P	Power supply at CH4 high-side FET from battery
Back side	PowerPAD™	G	Must be soldered to achieve appropriate power dissipation. Should be connected to PGND to use a $\Phi$ 0.3-mm through hole.

**ABSOLUTE MAXIMUM RATINGS<sup>(1)</sup>**

over operating free-air temperature range (unless otherwise noted)

			UNIT
Input voltage range	V <sub>CC1</sub> , V <sub>CC2</sub> , V <sub>CC3</sub> , V <sub>CC4</sub> , V <sub>CC5</sub> , V <sub>CC6</sub> , SWOUT, FB2, FB4, FB5, FB8, FBC, FBV, PS, XSLEEP, ENAFE, SEQ56, EN56, EN7, SW4S, SW4I, V <sub>OUT4</sub> , V <sub>OUT2</sub> , SW1, SW3, SW8LD, SW8HD, FBG78 (based on PGND or AGND)	–0.3 to 6	V
	SW2S, SW2I	–0.3 to 7	
	BADJ, SS, FB1, FB3, FB6, SS56	–0.3 to 3	
	LL8	–0.3 to 7	
	REF	–0.3 to 3.6	
	SW5	–0.3 to 22	
	SW7, CIN	–0.3 to 27	
	SW6 (based on V <sub>CC6</sub> )	–20	
	PGND1, PGND2, PGND3, PGND4, PGND57, AGND	–0.3 to 0.3	
Switching current	CIN	0.05	A
	SW2S, SW2I	3.3	
	SW4S, SW4I	1.65	
	SW1	1.9	
	SW3	1	
	SW5	1.6	
	SW6	–1.35	
	SW7	1.2	
	LL8	1	
	SW8LD, SW8HD	0.6	
T <sub>J</sub> Maximum junction temperature range		–30 to 150	°C
T <sub>stg</sub> Storage temperature range		–40 to 150	°C
ESD rating, Human-Body Model (HBM)	JEDEC JESD22A-A114	2	kV
ESD rating, Charged-Device Model (CDM)	JEDEC JESD22A-C101	500	V

(1) Stresses beyond those listed under "absolute maximum ratings" may cause permanent damage to the device. These are stress ratings only, and functional operation of the device at these or any other conditions beyond those indicated under "recommended operating conditions" is not implied. Exposure to absolute-maximum-rated conditions for extended periods may affect device reliability.

**DISSIPATION RATINGS**

PACKAGE	R <sub>θJA</sub> <sup>(1)</sup>	POWER RATINGS T <sub>A</sub> < 25°C	POWER RATINGS RATE T <sub>A</sub> > 25°C
48-pin QFN	27°C/W	2.9 W	0.029°C/W

(1) The thermal resistance, R<sub>θJA</sub>, is based on a soldered PowerPAD package on a 2S2P JEDEC board (3-in × 3-in, four layers) using thermal vias (0.3-mm diameter × 12 vias)

**RECOMMENDED OPERATING CONDITIONS**

		MIN	MAX	UNIT
Supply voltage	V <sub>CC1</sub> , V <sub>CC2</sub> , V <sub>CC4</sub> , V <sub>CC5</sub>	1.5	5.5	V
	V <sub>CC3</sub> , V <sub>CC6</sub>	2.5	5.5	
High-level input voltage	XSLEEP, ENAFE, EN56, EN7	1.4		V
	SEQ56	1.4	REF	
Low-level input voltage	XSLEEP, ENAFE, EN56, EN7, SEQ56		0.4	V
Operating temperature		–25	85	°C

**ELECTRICAL CHARACTERISTICS**

0°C ≤ T<sub>J</sub> ≤ 125°C, 1.8 V ≤ V<sub>CC2</sub> ≤ 5 V (unless otherwise noted)

PARAMETER		TEST CONDITIONS	MIN	TYP <sup>(1)</sup>	MAX	UNIT
<b>For All Circuits</b>						
I <sub>CC_Iq</sub>	Consumption current at PS (pin 29)	V <sub>CC2</sub> = VPS = 3.6 V, XSLEEP = AGND		1	10	μA
I <sub>CC_sleep</sub>		V <sub>CC2</sub> = 3.6 V, VPS = 5 V, XSLEEP = AGND, ENAFE = V <sub>CC2</sub>		40	70	
I <sub>CC_PWM</sub>		V <sub>CC2</sub> = 3.6 V, VPS = 5 V, XSLEEP = V <sub>CC2</sub> , ENAFE = V <sub>CC2</sub> , EN56 = V <sub>CC2</sub> , EN7 = V <sub>CC2</sub>		20	30	
I <sub>CC_Iq2</sub>	Consumption current at V <sub>CC2</sub> (pin 12)	V <sub>CC2</sub> = VPS = 3.6 V, XSLEEP = AGND		1	10	μA
I <sub>CC_sleep2</sub>		V <sub>CC2</sub> = 3.6 V, VPS = 5 V, XSLEEP = AGND, ENAFE = V <sub>CC2</sub>		12	30	
I <sub>CC_PWM2</sub>		V <sub>CC2</sub> = 3.6 V, VPS = 5 V, XSLEEP = V <sub>CC2</sub> , ENAFE = V <sub>CC2</sub> , EN56 = V <sub>CC2</sub> , EN7 = V <sub>CC2</sub>		0.3	1	
TSD	Thermal shutdown temperature <sup>(2)</sup>			150		°C
V <sub>(UV_ON)</sub>	UVLO detect level	V <sub>CC2</sub> from 0 V to 5.5 V, XSLEEP = V <sub>CC2</sub>	1.25	1.4	1.55	V
V <sub>(UV_OFF)</sub>	UVLO hysteresis	V <sub>CC2</sub> from 5.5 V to 0 V	50	100	150	mV
OSC	Internal OSC frequency	V <sub>CC2</sub> = 3.6 V	1.35	1.5	1.65	MHz
O <sub>SC_SUB</sub>	CH5–8 switching frequency	OSC = 1.5 MHz, VPS = 5 V		750		KHz
	REF output voltage	XSLEEP = V <sub>CC2</sub>	2.72	2.8	3.03	V
I <sub>SS</sub>	SS source current	S/S = AGND	6	10	14	μA
	Pulldown resistance at XSLEEP, ENAFE, EN56, EN7, SEQ56	XSLEEP = ENAFE = EN56 = EN7 = SEQ56 = 3 V		200		kΩ
<b>CH1</b>						
V <sub>CC1</sub>	Supply voltage		1.5		5.5	V
V <sub>OUT1</sub>	Output voltage <sup>(2)</sup>		0.9		2.5	V
I <sub>OUT1</sub>	Output current <sup>(2)</sup>	V <sub>CC1</sub> > 2.4 V, V <sub>OUT1</sub> = 1.2 V, Feedback resistance: R1 = 330 kΩ, R2 = 330 kΩ			600	mA
V <sub>FB1</sub>	FB1 reference voltage	No load	0.59	0.6	0.61	V
	Overcurrent protection threshold			0.9	1.9	A
	Overvoltage protection threshold (sensing at FB1 pin)		0.67	0.75	0.83	V
	High-side Nch FET ON resistance <sup>(3)</sup>	VPS = 5 V		320	500	mΩ
	Low-side Nch FET ON resistance <sup>(3)</sup>	VPS = 5 V		200	250	mΩ
	Trigger voltage to start CH3			0.48		V
	Trigger voltage to power off LDO			0.25		V
<b>CH2</b>						
V <sub>CC2</sub>	Supply voltage		1.5		5.5	V
V <sub>OUT2</sub>	Output voltage <sup>(2)</sup>		2.5		3.6	V
I <sub>OUT2</sub>	Output current <sup>(2)</sup>	V <sub>CC2</sub> > 2.4 V, V <sub>OUT2</sub> = 3.3 V, Feedback resistance: R1 = 180 kΩ, R2 = 820 kΩ			600	mA
V <sub>FB2</sub>	FB2 reference voltage	No load	0.595	0.605	0.615	V
	Overcurrent protection threshold			2.6	3.3	A
	Overvoltage protection threshold (sensing at FB2 pin)		0.67	0.75	0.83	V
Buck side <sup>(3)</sup>	High-side FET ON resistance	VPS = 5 V		100	210	mΩ
	Low-side FET ON resistance	VPS = 5 V		450	600	

(1) T<sub>A</sub> = 25°C  
 (2) Specified by design  
 (3) The value of FET ON resistance includes the resistance of bonding wire.

**ELECTRICAL CHARACTERISTICS (continued)**
 $0^{\circ}\text{C} \leq T_j \leq 125^{\circ}\text{C}$ ,  $1.8\text{ V} \leq V_{\text{CC}2} \leq 5\text{ V}$  (unless otherwise noted)

PARAMETER		TEST CONDITIONS	MIN	TYP <sup>(1)</sup>	MAX	UNIT
Boost side <sup>(3)</sup>	High-side FET ON resistance	VPS = 5 V		130	240	mΩ
	Low-side FET ON resistance	VPS = 5 V		80	140	
Trigger voltage to power off CH3		V <sub>OUT2</sub> = 0.5 V		0.5		V
V <sub>OUT2</sub> leakage current		V <sub>OUT2</sub> = 0.5 V			1	μA
Nch FET ON resistance for discharge		XSLEEP = AGND, ENAFE = AGND		1	2	kΩ
<b>CH3</b>						
V <sub>CC3</sub>	Supply voltage		2.5		5.5	V
V <sub>OUT3</sub>	Output voltage <sup>(2)</sup>		0.9		2.5	V
I <sub>OUT3</sub>	Output current <sup>(2)</sup>	V <sub>CC3</sub> > 2.5 V, V <sub>OUT3</sub> = 1.8 V, Feedback resistance: R1 = 220 kΩ, R2 = 470 kΩ			300	mA
V <sub>FB3</sub>	FB3 reference voltage	No load	0.59	0.6	0.61	V
Overcurrent protection threshold				0.6	1	A
Overvoltage protection threshold (sensing at FB3 pin)			0.67	0.75	0.83	V
High-side Nch FET ON resistance <sup>(4)</sup>		VPS = 5 V		370	750	mΩ
Low-side Nch FET ON resistance <sup>(4)</sup>		VPS = 5 V		300	600	mΩ
Nch FET ON resistance for discharge		XSLEEP = AGND, ENAFE = AGND		1	2	kΩ
Trigger voltage to start CH2				0.48		V
Trigger voltage to power off CH1				0.2		V
<b>CH4</b>						
V <sub>CC4</sub>	Supply voltage		1.5		5.5	V
V <sub>OUT4</sub>	Output voltage <sup>(5)</sup>		2.2		3.6	V
I <sub>OUT4</sub>	Output current <sup>(5)</sup>	V <sub>CC4</sub> > 2.4 V, V <sub>OUT4</sub> = 3.3 V, Feedback resistance: R1 = 82 kΩ, R2 = 330 kΩ		100	300	mA
V <sub>FB4</sub>	FB4 reference voltage	No load	0.595	0.605	0.615	V
Overcurrent protection threshold				1.4	1.65	A
Overvoltage protection threshold (sensing at FB4 pin)			0.67	0.75	0.83	V
Buck side <sup>(4)</sup>	High-side FET ON resistance	VPS = 5 V		130	310	mΩ
	Low-side FET ON resistance	VPS = 5 V		600	730	
Boost side <sup>(4)</sup>	High-side FET ON resistance	VPS = 5 V		170	270	mΩ
	Low-side FET ON resistance	VPS = 5 V		130	250	
V <sub>OUT4</sub> leakage current		V <sub>OUT4</sub> = 0.5 V			1	μA
Nch FET ON resistance for discharge		XSLEEP = AGND, ENAFE = AGND		1	2	kΩ
<b>CH5</b>						
V <sub>CC5</sub>	Supply voltage		1.5		5.5	V
V <sub>OUT5</sub>	Output voltage <sup>(5)</sup>		V <sub>CC5</sub>		18	V
V <sub>FB5</sub>	FB5 reference voltage	No load	0.98	1	1.02	V
I <sub>OUT5</sub>	Output current <sup>(5)</sup>	V <sub>CC5</sub> > 2.4 V, V <sub>OUT5</sub> = 15 V, Feedback resistance: R1 = 40 kΩ, R2 = 560 kΩ			50	mA

(4) The value of FET ON resistance includes the resistance of bonding wire.

(5) Specified by design

**ELECTRICAL CHARACTERISTICS (continued)**

0°C ≤ T<sub>J</sub> ≤ 125°C, 1.8 V ≤ V<sub>CC2</sub> ≤ 5 V (unless otherwise noted)

PARAMETER		TEST CONDITIONS	MIN	TYP <sup>(1)</sup>	MAX	UNIT
	Overcurrent protection threshold			1.3	1.6	A
	Overvoltage protection threshold (sensing at FB5 pin)		1.09	1.25	1.38	V
	Nch FET ON resistance <sup>(4)</sup>	VPS = 5 V		610	900	mΩ
	Load switch ON resistance (between V <sub>CC5</sub> and SW5)	1.5 V < V <sub>CC5</sub> < 5.5 V		100	470	mΩ
	Load switch ramp-up time (between V <sub>CC5</sub> and SW5) <sup>(5)</sup>	1.5 V < V <sub>CC5</sub> < 5.5 V, SWOUT capacitance = 4.7 μF		200		μS
	Load switch leakage current (between V <sub>CC5</sub> and SW5)				1	μA
	Max duty cycle		96	98		%
	Trigger voltage to start up CH6	SEQ56 = AGND		0.8		V
<b>CH6</b>						
V <sub>CC6</sub>	Supply voltage		2.5		5.5	V
V <sub>OUT6</sub>	Output voltage <sup>(5)</sup>		-10		-5	V
I <sub>OUT6</sub>	Output current <sup>(5)</sup>	V <sub>CC6</sub> > 2.8 V, V <sub>OUT6</sub> = -7.5 V, Feedback resistance: R1 = 136 kΩ, R2 = 820 kΩ			100	mA
V <sub>FB6</sub>	FB6 reference voltage	No load	-0.02	0	0.02	V
	Overcurrent protection threshold	V <sub>CC6</sub> > 2.8 V		1.1	1.35	A
	Overvoltage protection threshold (sensing at FB6 pin)		-0.3	-0.2	-0.1	V
	Pch FET ON resistance <sup>(6)</sup>	V <sub>CC6</sub> = 3.6 V		640	1100	mΩ
	Max duty cycle		84	91	98	%
	Trigger voltage to power off CH6	SEQ56 = AGND	0.5	0.53	0.56	V
V <sub>S/S56</sub>	S/S56 pin voltage		1.22	1.25	1.28	V
I <sub>S/S56</sub>	S/S56 pin source current	S/S56 = AGND	170	200	230	μA
<b>CH7</b>						
V <sub>CC7</sub>	Supply voltage <sup>(7)</sup>		1.5		5.5	V
V <sub>OUT7</sub>	Output voltage <sup>(8)</sup>	V <sub>CC7</sub> < V <sub>OUT7</sub>	3		20	V
I <sub>OUT7_L</sub>	Lower output current <sup>(7)</sup>	V <sub>CC7</sub> > 2.4 V, V <sub>OUT7</sub> = 15 V, Feedback resistance: R1 = 47 kΩ, R2 = 680 kΩ, R <sub>sense</sub> = 10 Ω, B_ADJ pin voltage = 0 V	3.7	5	6.3	mA
I <sub>OUT7_H</sub>	Higher output current <sup>(7)</sup>	V <sub>CC7</sub> > 2.4 V, V <sub>OUT7</sub> = 15 V, Feedback resistance: R1 = 47 kΩ, R2 = 680 kΩ, R <sub>sense</sub> = 10 Ω, B_ADJ pin voltage = 1 V	23.7	25	26.3	mA
V <sub>FBV</sub>	FBV reference voltage	No load	0.97	1	1.03	V
	Overvoltage protection threshold (sensing at FBV pin)		1.15	1.25	1.35	V
	Overcurrent protection threshold			0.8	1.2	A
	Nch FET ON resistance <sup>(6)</sup>			700	1200	mΩ
	Max duty cycle		86	91	99	%
	Load switch ON resistance			2	4	Ω
	Load switch leakage current (between C-IN and FBC)				1	μA
R <sub>B-ADJ</sub>	B-ADJ pin input impedance			1		MΩ

(6) The value of FET ON resistance includes the resistance of bonding wire.

(7) Specified by design

(8) Due to constant current control for CH7, the operating condition is that Input voltage is less than LED supply voltage (output voltage).

**ELECTRICAL CHARACTERISTICS (continued)**
 $0^{\circ}\text{C} \leq T_J \leq 125^{\circ}\text{C}$ ,  $1.8\text{ V} \leq V_{CC2} \leq 5\text{ V}$  (unless otherwise noted)

PARAMETER		TEST CONDITIONS	MIN	TYP <sup>(1)</sup>	MAX	UNIT
<b>CH8</b>						
Supply voltage <sup>(7)</sup>		$T_A = 25^{\circ}\text{C}$ , Start up (XSLEEP from AGND to $V_{CC2}$ )	1.8		5.5	V
		XSLEEP = $V_{CC2}$	1.5		5.5	
VPS	Output voltage <sup>(7)</sup>		3.3		5.5	V
$V_{FB8}$	FB8 reference voltage	XSLEEP = H, ENAFE = AGND, No load	1.23	1.25	1.27	V
		CH8 operation mode: PFM mode, No load	1.2	1.25	1.35	
Fixed ON time at PFM mode		$V_{CC2} = 3.6\text{ V}$		250		ns
Max duty cycle			76	85	92	%
SW8LD driver	Source impedance	VPS = 5 V, ISW = 100 mA		5	7.5	$\Omega$
	Sink impedance	VPS = 5 V, ISW = -100 mA		1	1.5	
SW8HD driver	Source impedance	VPS = 5 V, ISW = 100 mA		10	15	$\Omega$
	Sink impedance	VPS = 5 V, ISW = -100 mA		5	7.5	
Overvoltage protection threshold (sensing at FB8 pin)			1.3	1.56	1.8	V
FBG7/8 FET ON resistance		VPS = 5 V, XSLEEP = $V_{CC2}$		0.6		k $\Omega$
FBG7/8 leakage current		XSLEEP = AGND, ENAFE = AGND			1	$\mu\text{A}$

**BLOCK DIAGRAM**

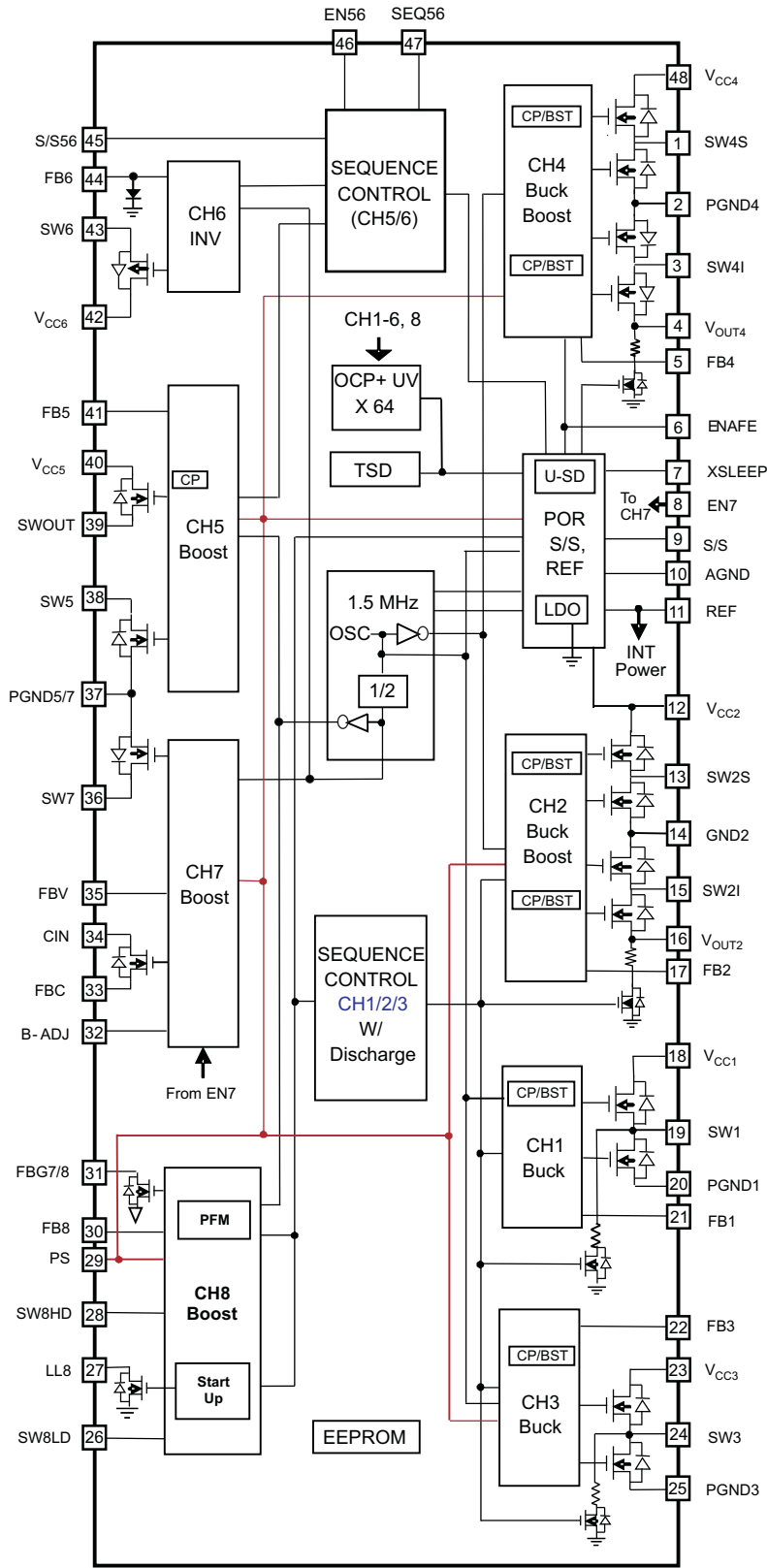

APPLICATION INFORMATION

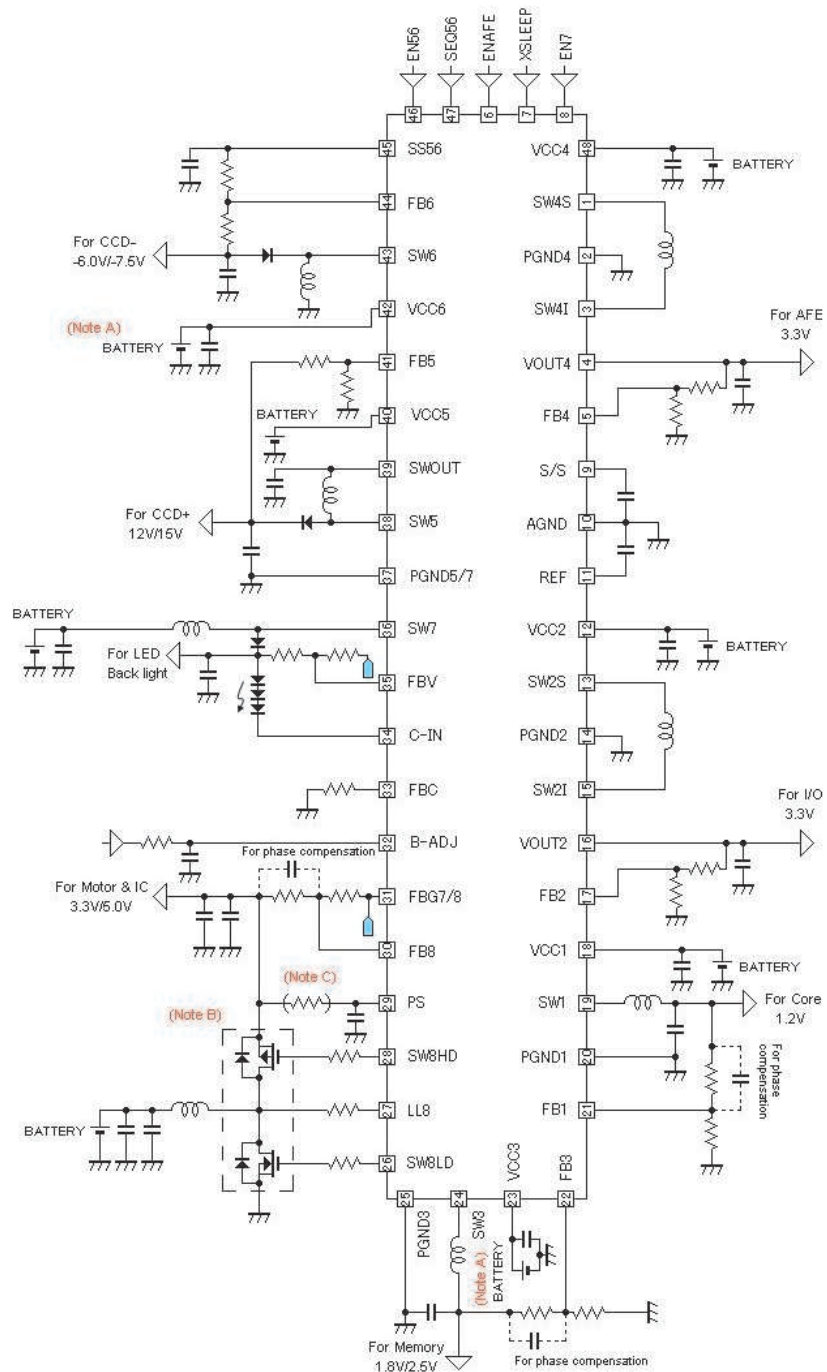

- A. When output voltage is higher than input voltage at 2AA battery models, V<sub>CC1</sub> and V<sub>CC3</sub> should be connected to the CH8 output. When the 2AA battery is connected, V<sub>CC6</sub> should be connected to the CH8 output.
- B. The external FET for CH8 is dependent on the load. When the motor is connected to CH8, the external FET is large.
- C. It is acceptable to connect directly to PS without resistor.

## FUNCTIONAL DESCRIPTION

### Logic True Table

The enable/disable of each channel is controlled by logic input signals level at XSLEEP (pin 7 for all channels), ENAFE (pin 6 for CH4), EN56 (pin 46 for CH5/6) and EN7 (pin 8 for CH7). Table 1 is the summary of the enable/disable mode.

Table 1. Control Pin vs Enable/Disable

NO. OF STATE	XSLEEP	ENAFE	EN56	EN7	CH1	CH2	CH3	CH4	CH5	CH6	CH7	CH8 <sup>(1)</sup>	LDO
1	L	L	–	–	OFF	OFF	OFF	OFF	OFF	OFF	OFF	OFF	OFF
2	H	L	L	L	ON	ON	ON	OFF	OFF	OFF	OFF	PWM	ON
3	H	L	L	H	ON	ON	ON	OFF	OFF	OFF	ON	PWM	ON
4	H	L	H	L	ON	ON	ON	OFF	ON	ON	OFF	PWM	ON
5	H	L	H	H	ON	ON	ON	OFF	ON	ON	ON	PWM	ON
6	H	H	L	L	ON	ON	ON	ON	OFF	OFF	OFF	PWM	ON
7	H	H	L	H	ON	ON	ON	ON	OFF	OFF	ON	PWM	ON
8	H	H	H	L	ON	ON	ON	ON	ON	ON	OFF	PWM	ON
9	H	H	H	H	ON	ON	ON	ON	ON	ON	ON	PWM	ON
10 <sup>(2)</sup>	L	H	–	–	OFF	OFF	OFF	OFF	OFF	OFF	OFF	PFM	OFF

- (1) PWM = pulse width modulation, PFM = pulse frequency modulation
- (2) State 10 (CH8: PFM mode) must go through State 2.

### Power ON/OFF Sequence

This device has the power ON/OFF sequence of CH1/2/3/8/REF and CH5/6 for DSC application. The CH1/2/3/8/REF sequence is shown in Figure 1. The CH5/6 sequence is shown in Figure 2. CH4 and CH7 have individual sequences but CH4–6 have the subordinate relationship with CH1–3 because the slope of soft start is the same and puts high priority of CH1–3 to avoid the functional conflict (see the Soft Start description). Due to this, CH4–6 should not be ON before CH1–3 are ON. When XSLEEP is forced low, all channels turn OFF with the power OFF sequence.

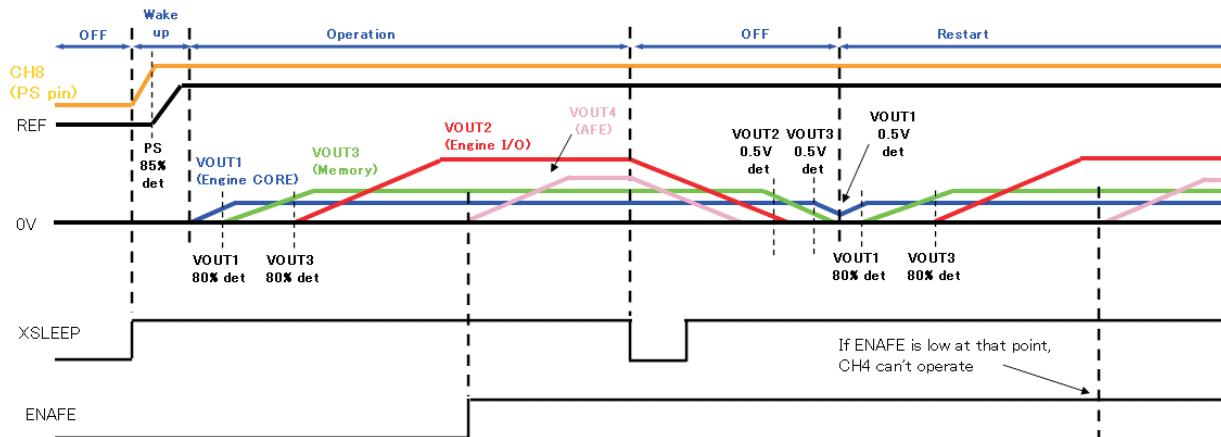

Figure 1. CH1/CH2/CH3/CH8/REF Power ON/OFF Sequence

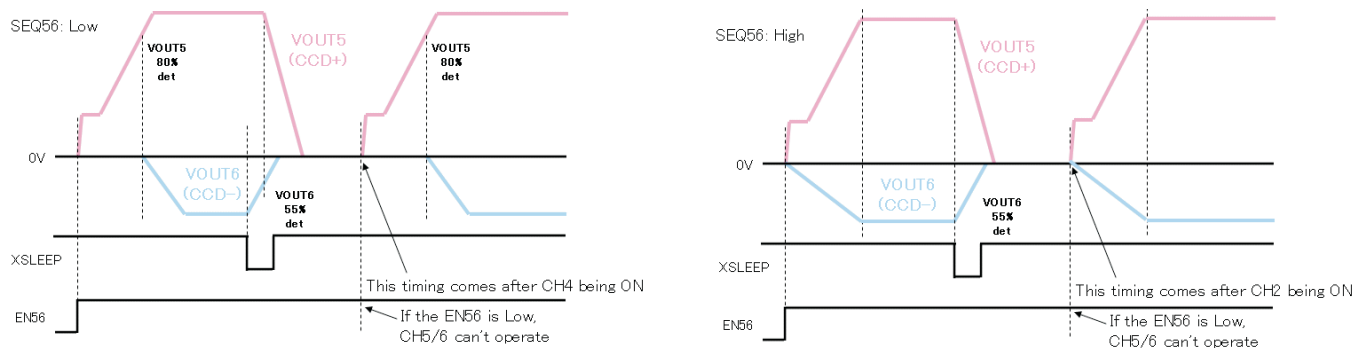

Figure 2. CH5/6 Power ON/OFF Sequence

### Soft Start

This function reduces the rush current from the battery at start-up. This device has two slopes defined by S/S (pin 9) and S/S56 (pin 45). The slopes of CH1–4 are defined by S/S; the slopes of CH5/6 depend on SEQ56 (pin 47) signal level. When SEQ56 is low, the slope of CH5 is defined by S/S; the slope of CH6 is defined by S/S56. When SEQ56 is high, the slopes of CH5/6 are defined by S/S56. The soft-start time is calculated by Equation 1 and Equation 2.

$$T_{S/S} = C_{S/S} \times 60 \quad (1)$$

$$T_{S/S56} = C_{S/S56} \times 6.25 \quad (2)$$

Where:

$C_{S/S}$  = Capacitance at S/S [ $\mu$ F]

$T_{S/S}$  = Soft-start duration defined by S/S [ms]

$C_{S/S56}$  = Capacitance at S/S56 [ $\mu$ F]

$T_{S/S56}$  = Soft-start duration defined by S/S56 [ms]

The recommended capacitances are  $C_{S/S} = 0.1$  [ $\mu$ F] or  $T_{S/S} = 6.0$  [ms],  $C_{S/S56} = 1.0$  [ $\mu$ F] or  $T_{S/S56} = 6.25$  [ms].

### Undervoltage Lockout (UVLO)

This device monitors the battery voltage level at  $V_{CC2}$  (pin 12) When XSLLEEP is high and  $V_{CC2}$  is less than the threshold (defined in Electrical Characteristics as UVLO detect level), the operation shuts down immediately without the power OFF sequence. UVLO has a hysteresis as shown in Figure 3. This factor is defined in Electrical Characteristics as UVLO hysteresis.

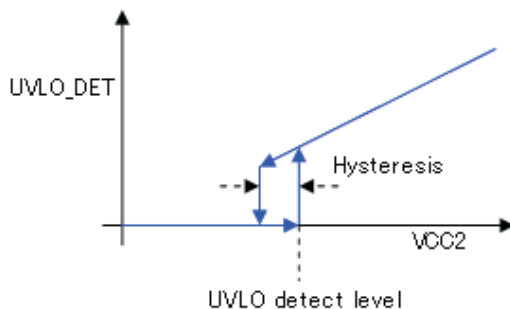

Figure 3. UVLO Hysteresis

### Protection

The TPS65530A has three protection conditions: overcurrent protection (OCP), overvoltage protection (OVP), and thermal shutdown (TSD) (see Table 2).

**Table 2. Protection Conditions**

PROTECTION		CH1–CH6	CH7	CH8	REF (LDO)
OCP	Change mode	All CH shutdown (latch-off) (without power OFF sequence)	Forced OFF at MOSFET	All CH shutdown (latch-off) (without power OFF sequence)	All CH shutdown (latch-off) (without power OFF sequence)
	Detect condition	Current over the threshold, $V_{OUT}$ less than 80% to compare the target, and count 64 cycle $\times$ 1.5 MHz	Current over the threshold	$V_{OUT}$ less than 70% to compare the target	$V_{OUT}$ less than 80% to compare the target
	Comeback condition	XSLEEP: Change level from Low to High ENAFE: Change level from Low to High (for CH4) EN56: Change level from Low to High (for CH5/6) or $V_{CC2}$ : Apply more than UVLO threshold (1.4 V) after removing $V_{CC2}$	Current less than the threshold (automatic restoration) or $V_{CC2}$ : Apply more than UVLO threshold (1.4 V) after removing $V_{CC2}$	XSLEEP: Change level from Low to High ENAFE: Change level from Low to High or $V_{CC2}$ : Apply more than UVLO threshold (1.4 V) after removing $V_{CC2}$	XSLEEP: Change level from Low to High ENAFE: Change level from Low to High or $V_{CC2}$ : Apply more than UVLO threshold (1.4 V) after removing $V_{CC2}$
OVP	Change mode	Forced OFF at applicable CH MOSFET	Forced OFF at MOSFET, load switch turns ON	Forced OFF at MOSFET	No OVP function
	Detect condition	Voltage over the threshold at feedback	Voltage over the threshold at feedback	Voltage over the threshold at feedback	
	Comeback condition	Voltage less than the threshold at feedback (auto-recovery)	EN7: Change level from Low to High	Voltage less than the threshold at feedback (auto-recovery)	
TSD	Change mode	All CH shutdown (without power OFF sequence)			
	Detect condition	The junction temperature is more than the threshold.			
	Comeback condition	XSLEEP: Change level from Low to High, ENAFE: Change level from Low to High (for CH4), EN56: Change level from Low to High (for CH5/6), or $V_{CC2}$ : More than 1.4 V			

**CHANNEL DESCRIPTIONS**

**CH1/3 Description**

Both CH1 and CH3 are the same topology. CH1/3 are the voltage-mode-controlled synchronous buck converters for engine core (CH1) or external memory (CH3). Both high-side and low-side switches are integrated into the device and consist of NMOS-FET only. The gate of the high-side switch is driven by bootstrap circuit. The capacitance of the bootstrap is included in the device. These channels are able to operate up to 100% duty cycle.

This device has a discharge path to use the switch (Q\_Discharge1/3) for the CH1/3 output capacitor via the inductor. The switch is activated after the power OFF sequence has started. Typical resistance at the discharge circuit is 1 k $\Omega$ . When the device detects the threshold at FB1/3 after the power OFF sequence has started, the MOSFET turns OFF and the output is fixed with high impedance.

It is acceptable to connect the battery to  $V_{CC1}/V_{CC3}$  (pins 18/23) directly when the battery voltage is more than 2.5 V. When the battery voltage is less than 2.5 V, the CH8 output should be connected to  $V_{CC1}/V_{CC3}$ .

The output voltage is programmed from 0.9 V to 2.5 V (both CH1 and CH3) to use the feedback loop sensed by the external resistances. The output voltage is calculated by Equation 3. The block diagram is shown in Figure 4.

$$V_{OUT} = (1 + R2/R1) \times 0.6 [V] \tag{3}$$

Where:

$V_{OUT}$  = Output voltage [V]

R1, R2 = Feedback resistance (see Figure 4)

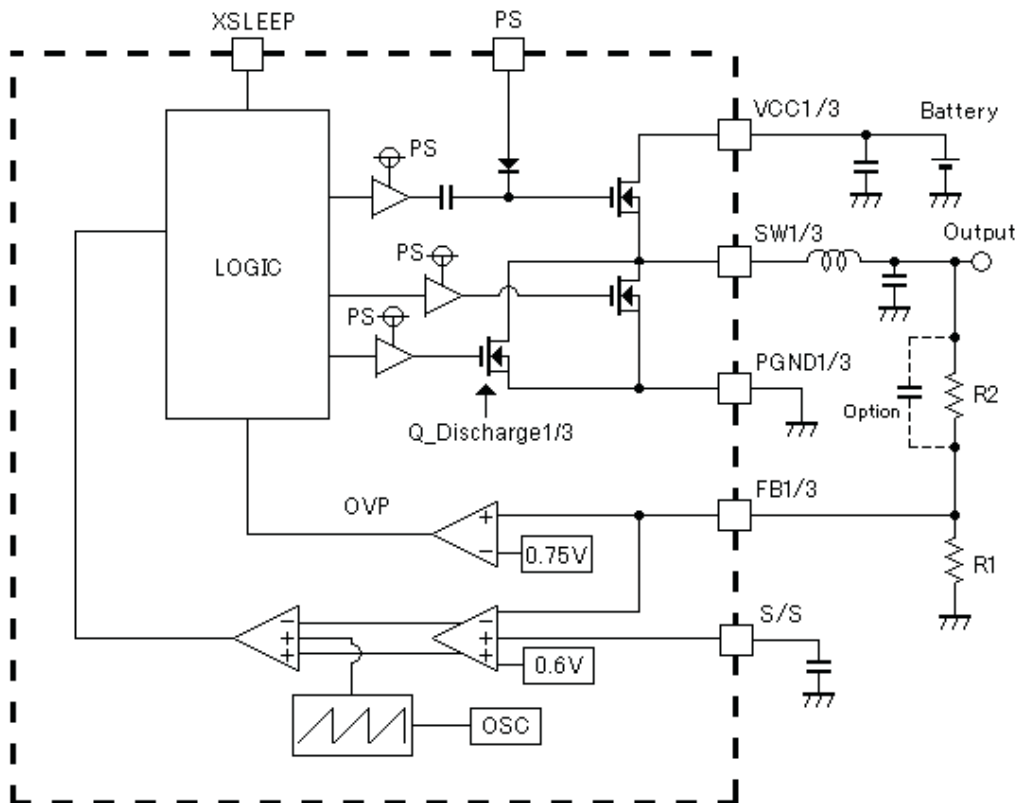

Figure 4. CH1/3 Block Diagram

CH1/3 Recommended Parts

Table 3. Recommended Parts for Inductor (CH1/3)

VENDOR	TYPE NO.	INDUCTANCE (μH)	DCR (mΩ)	SIZE (mm)
TOKO	DE2812C-1098AS-4R7M	4.7	130	2.8 × 3.0 × 1.2

Table 4. Recommended Parts for Capacitor (Input, CH1/3)

VENDOR	TYPE NO.	CAPACITANCE (μF)	TOLERANCE (%)	SIZE (mm)
Murata	GRM21BB30J226ME38	22.0	20	2.0 × 1.25 × 1.25 (EIA code: 0805)

Table 5. Recommended Parts for Capacitor (Output, CH1/3)

VENDOR	TYPE NO.	CAPACITANCE (μF)	TOLERANCE (%)	SIZE (mm)
TDK	C2012X5R0J106M	10.0	20	2.0 × 1.25 × 1.25 (EIA code: 0805)

CH2/4 Description

Both CH2 and CH4 are the same topology. CH2/4 are the average current-mode-controlled synchronous back-boost converters for engine I/O (CH2) or AFE (CH4). This converter is an adapted H-bridge circuit to use four switches. These switches are integrated into the device and consist of NMOS-FET only. The gate of the high-side switch is controlled by the bootstrap circuit. The capacitance of the bootstrap is included in the device.

The device automatically switches from buck operation to boost operation or from boost operation to buck operation as required by the configuration. It always uses one active switch, one rectifying switch, one switch permanently on, and one switch permanently off. Therefore, it operates as a buck converter when the input voltage is higher than the output voltage, and as a boost converter when the input voltage is lower than the output voltage. There is no mode of operation in which all four switches are permanently switching.

This device has a discharge switch (Q\_Discharge2/4) for the CH2/4 output capacitor. The typical ON resistance at the discharge switch is 1 kΩ. The discharge switch is activated when XSLEEP turns low. For CH4 only, the switch is also activated when ENAFE turns low. After output voltage reaches approximately 0.5 V, the discharge switch turns OFF and V<sub>OUT2</sub>/V<sub>OUT4</sub> is changed into high impedance. The output voltage is programmable from 2.5 V to 3.6 V (for CH2) or from 2.2 V to 3.6 V (for CH4) to use the feedback loop sensed by the external resistances. The output voltage is calculated by Equation 4. The block diagram is shown in Figure 5.

$$V_{OUT} = (1 + R2/R1) \times 0.6 \text{ [V]} \tag{4}$$

Where:

V<sub>OUT</sub> = Output voltage [V]

R1, R2 = Feedback resistance (see Figure 5)

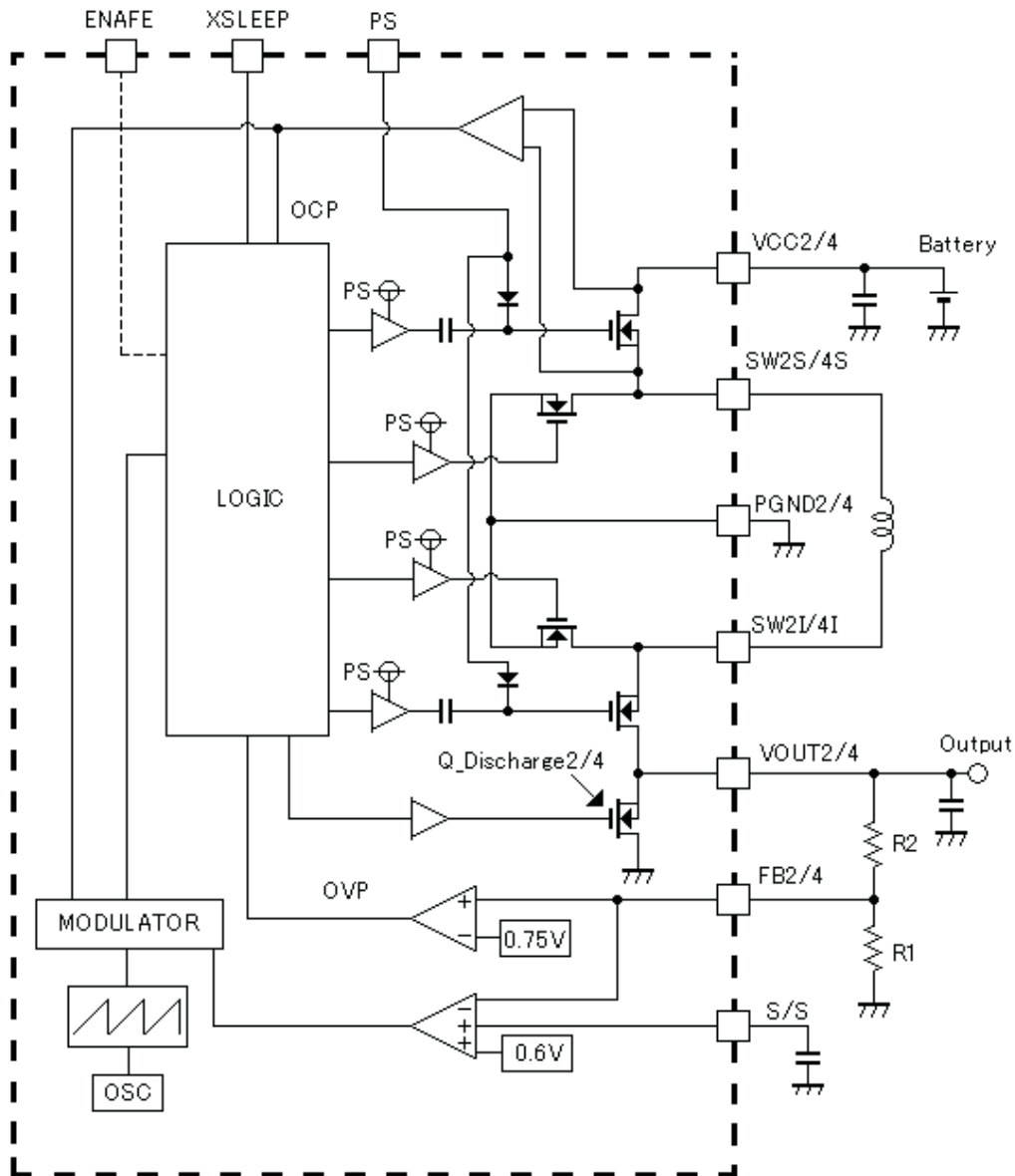

Figure 5. CH2/4 Block Diagram

**CH2/4 Recommended Parts**
**Table 6. Recommended Parts for Inductor (CH2)**

VENDOR	TYPE NO.	INDUCTANCE (μH)	DCR (mΩ)	SIZE (mm)
TOKO	DE2812C-1098AS-2R7M	2.7	72	2.8 × 3.0 × 1.2

**Table 7. Recommended Parts for Inductor (CH4)**

VENDOR	TYPE NO.	INDUCTANCE (μH)	DCR (mΩ)	SIZE (mm)
TOKO	DE2812C-1098AS-4R7M	4.7	130	2.8 × 3.0 × 1.2

**Table 8. Recommended Parts for Capacitor (Input, CH2/4)**

VENDOR	TYPE NO.	CAPACITANCE (μF)	TOLERANCE (%)	SIZE (mm)
Murata	GRM21BB30J226ME38	22.0	20	2.0 × 1.25 × 1.25 (EIA code: 0805)

**Table 9. Recommended Parts for Capacitor (Output, CH2/4)**

VENDOR	TYPE NO.	CAPACITANCE (μF)	TOLERANCE (%)	SIZE (mm)
Taiyo Yuden	JMK212BJ476MG-T	47.0	20	2.0 × 1.25 × 1.25 (EIA code: 0805)

**CH5 Description**

CH5 is the peak current-mode-controlled nonsynchronous boost converter for CCD+. The switch between inductor and power GND is integrated into the device and consists of NMOS-FET. Also, this device has a load switch between the battery and inductor and consists of NMOS-FET. The gate of the switch is controlled by a charge-pump circuit. The output voltage is programmable up to 18 V to use the feedback loop sensed by the external resistances. The output voltage is calculated by [Equation 5](#). The block diagram is shown in [Figure 6](#).

$$V_{OUT5} = (1 + R2/R1) \times 1.0 \text{ [V]} \quad (5)$$

Where:

$V_{OUT5}$  = Output voltage of CH5 [V]

R1, R2 = Feedback resistance (see [Figure 6](#))

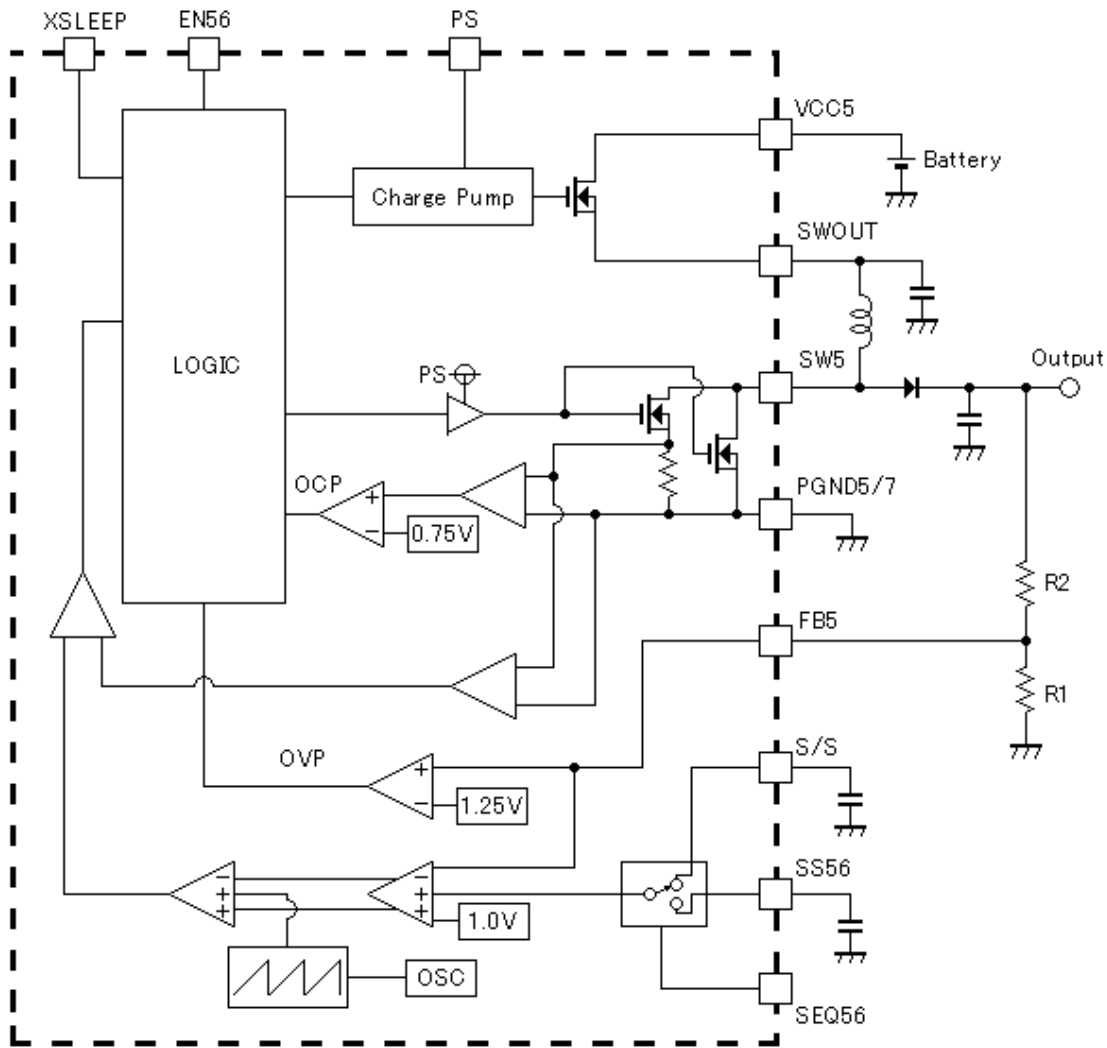

Figure 6. CH5 Block Diagram

CH5 Recommended Parts

Table 10. Recommended Parts for Inductor (CH5)

VENDOR	TYPE NO.	INDUCTANCE (μH)	DCR (mΩ)	SIZE (mm)
TOKO	DE2812C-1098AS-120M	12.0	340	2.8 × 3.0 × 1.2

Table 11. Recommended Parts for Capacitor (Output, CH5)

VENDOR	TYPE NO.	CAPACITANCE (μF)	TOLERANCE (%)	SIZE (mm)
Murata	GRM31CB31E106KA75	10.0	10	3.2 × 1.6 × 1.6 (EIA code: 1206)

Table 12. Recommended Parts for Capacitor (SWOUT, CH5)

VENDOR	TYPE NO.	CAPACITANCE (μF)	TOLERANCE (%)	SIZE (mm)
TDK	C2012X5R1A335M	3.3	20	2.0 × 1.25 × 1.25 (EIA code: 0805)

**Table 13. Recommended Parts for Diode (CH5)**

VENDOR	TYPE NO.	VR (V)	IF (mA)	VF (V)/IF (A)	CAPACITANCE (pF)	SIZE (mm)
Sanyo	SB0503EJ	30	500	0.55/0.5	16.5	1.6 × 0.8 × 0.6

**CH6 Description**

CH6 is the voltage-mode-controlled nonsynchronous inverting converter for CCD-. The switch between the input voltage and inductor is integrated into the device and consists of PMOS-FET. It is acceptable to connect the battery to V<sub>CC6</sub> (pin 42) directly when the battery voltage is more than 2.5 V. When the battery voltage is less than 2.5 V, the CH8 output should be connected to V<sub>CC6</sub>. The output voltage is programmable from -10 V to -5 V to use the feedback loop sensed by the external resistances. The output voltage is calculated by Equation 6. The block diagram is shown in Figure 7.

$$V_{OUT6} = 1.25 - (1 + R2/R1) \times 1.25 [V] \tag{6}$$

Where:

V<sub>OUT</sub> = Output voltage of CH6 [V]

R1, R2 = Feedback resistance (see Figure 7)

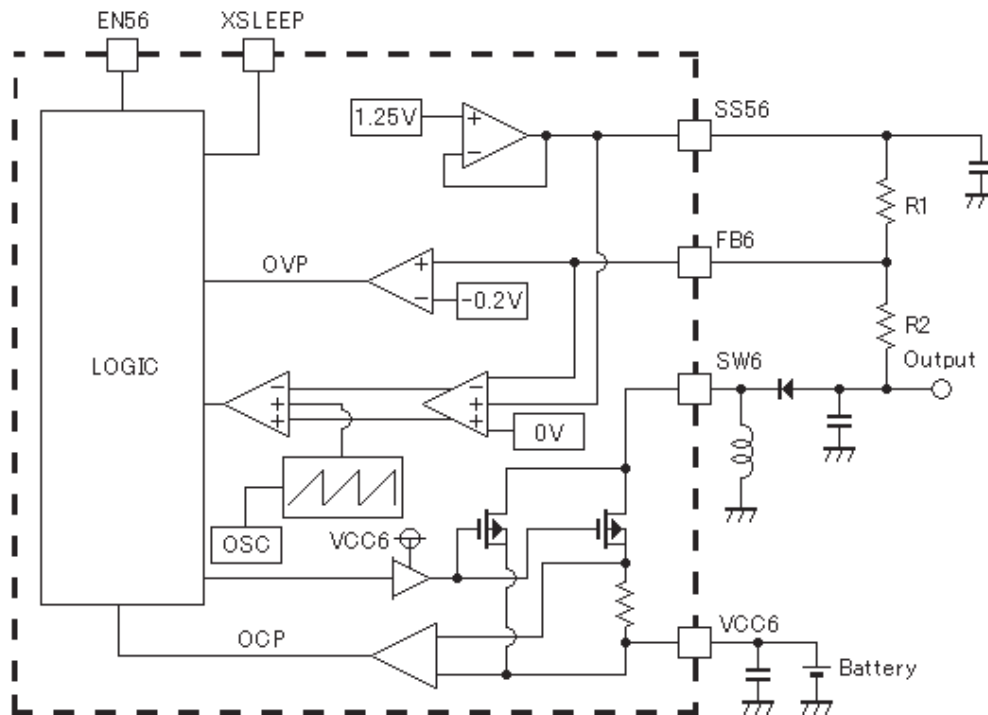

**Figure 7. CH6 Block Diagram**

**CH6 Recommended Parts**

**Table 14. Recommended Parts for Inductor (CH6)**

VENDOR	TYPE NO.	INDUCTANCE (μH)	DCR (mΩ)	SIZE (mm)
TOKO	DE2815C-1071AS-120M	12.0	240	2.8 × 3.0 × 1.2

**Table 15. Recommended Parts for Capacitor (Input, CH6)**

VENDOR	TYPE NO.	CAPACITANCE (μF)	TOLERANCE (%)	SIZE (mm)
Murata	GRM21BB31A106KE18	10.0	10	2.0 × 1.25 × 1.25 (EIA code: 0805)

**Table 16. Recommended Parts for Capacitor (Output, CH6)**

VENDOR	TYPE NO.	CAPACITANCE (μF)	TOLERANCE (%)	SIZE (mm)
Murata	GRM31CB31E106KA75	10.0	10	3.2 × 1.6 × 1.6 (EIA code: 1206)

**Table 17. Recommended Parts for Diode (CH6)**

VENDOR	TYPE NO.	VR (V)	IF (mA)	VF (V)/IF (A)	CAPACITANCE (pF)	SIZE (mm)
Sanyo	SB0503EJ	30	500	0.55/0.5	16.5	1.6 × 0.8 × 0.6

**CH7 Description**

CH7 is the voltage-mode-controlled nonsynchronous boost converter for the backlight LED. The switch between the inductor and power GND is integrated into the device and consists of NMOS-FET. Also, this device has a load switch to control the output current and consists of NMOS-FET. The output current is constant and is calculated by Equation 7. It is controlled by the B\_ADJ (pin 32) input voltage as shown in Figure 8. The B\_ADJ input voltage is required as an analog input. When it is required to input PWM signal for B\_ADJ, the RC filter is needed.

$$I_{LED} = \frac{0.2}{R_{SENSE}} \cdot V_{BADJ} + \frac{0.05}{R_{SENSE}} \tag{7}$$

Where:

$I_{LED}$  = Output current of CH7 [A]

$R_{SENSE}$  = Sense resistor between FBC and PGND5/7 [Ω]

$V_{BADJ}$  = B\_ADJ input voltage ( $0 < V_{BADJ} < 1$ ) [V]

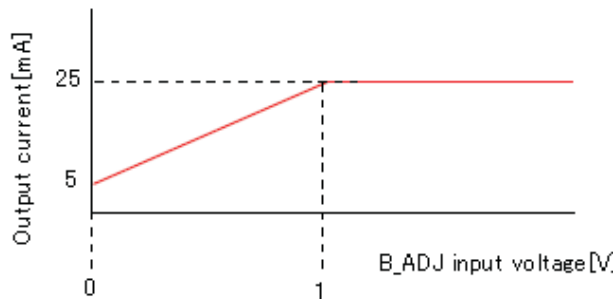

**Figure 8. Output Current vs B\_ADJ Input Voltage (RSENSE = 10 Ω)**

The principle of the operation is to adjust the duty cycle of the MOSFET. When the B\_ADJ input voltage is changed, the level of “A” point shown in Figure 9 is changed to get the desired duty cycle compared to the sense current.

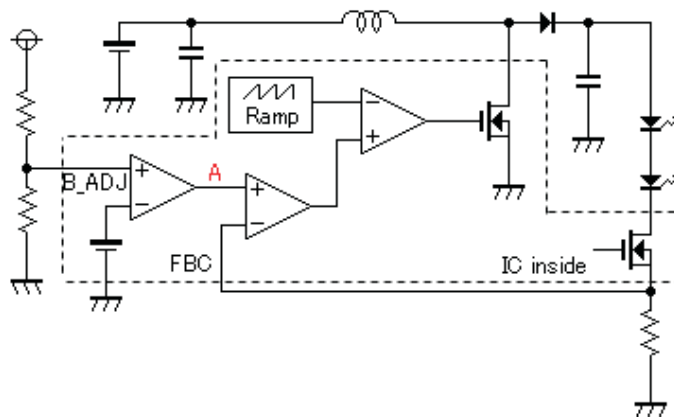

**Figure 9. LED Brightness Control Block Diagram**

At first, CH7 operates as pulse frequency modulation (PFM) mode at start-up. After reaching the target output voltage, CH7 operation is changed from PFM mode to pulse width modulation (PWM) mode automatically. The output voltage is programmable up to 20 V to use the feedback loop sensed by the external resistances. The maximum output voltage is calculated by [Equation 8](#). The block diagram is shown in [Figure 10](#).

$$V_{OUT7\ MAX} = 1 + (R2/R1) \times 1.25 \text{ [V]} \quad (8)$$

Where:

$V_{OUT7\ MAX}$  = Maximum output voltage of CH7 [V]

R1, R2 = Feedback resistance (see [Figure 10](#))

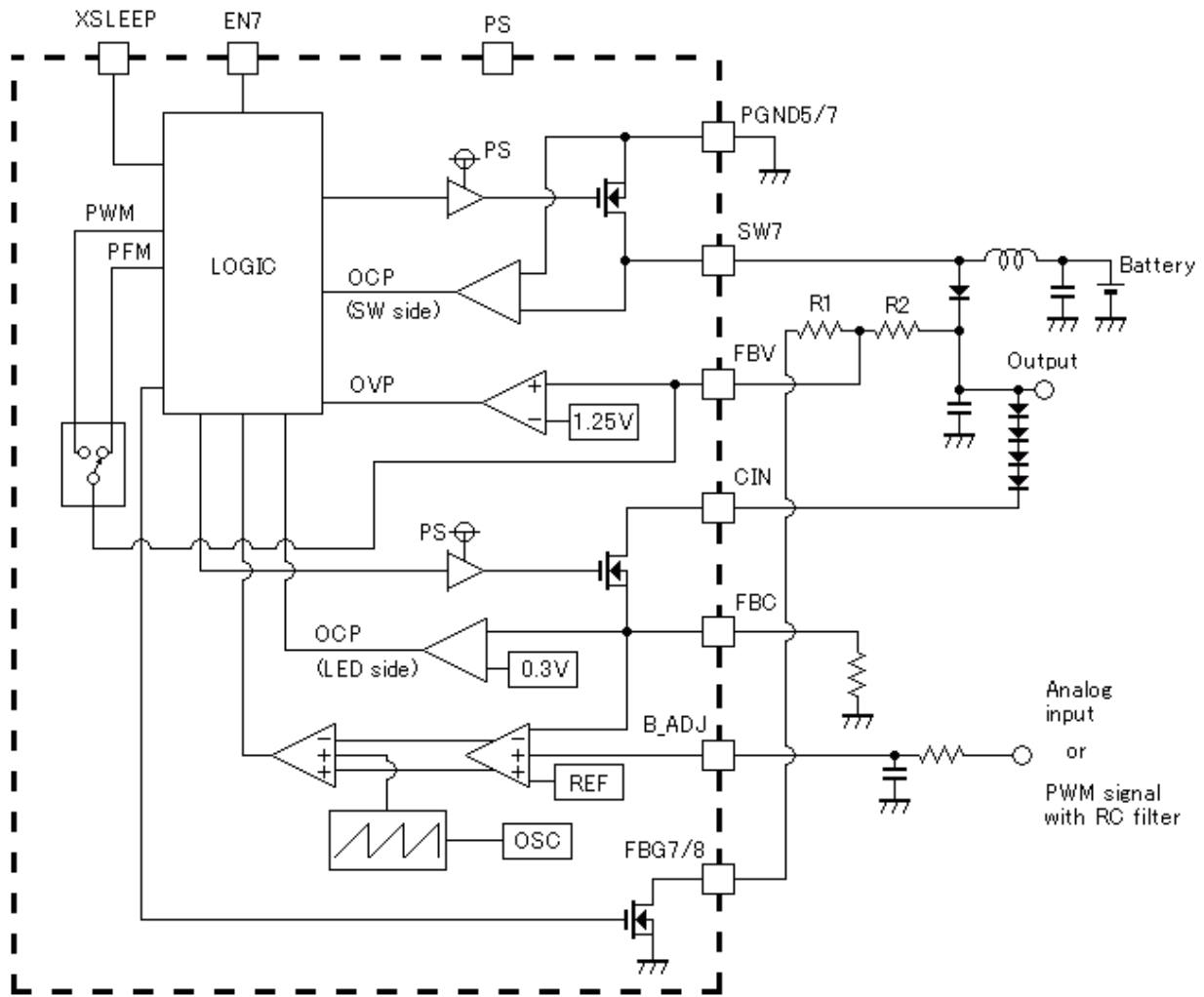

Figure 10. CH7 Block Diagram

CH7 Recommended Parts

Table 18. Recommended Parts for Inductor (CH7)

VENDOR	TYPE NO.	INDUCTANCE (μH)	DCR (mΩ)	SIZE (mm)
TOKO	DE2815C-1071AS-120M	12.0	240	2.8 × 3.0 × 1.2

Table 19. Recommended Parts for Capacitor (Input, CH7)

VENDOR	TYPE NO.	CAPACITANCE (μF)	TOLERANCE (%)	SIZE (mm)
Murata	GRM21BB31A106KE18	10.0	10	2.0 × 1.25 × 1.25 (EIA code: 0805)

Table 20. Recommended Parts for Diode (CH7)

VENDOR	TYPE NO.	VR (V)	IF (mA)	VF (V)/IF (A)	CAPACITANCE (μF)	SIZE (mm)
Sanyo	SB0503EJ	30	500	0.55/0.5	16.5	1.6 × 0.8 × 0.6

**Table 21. Recommended Parts for Capacitor (Output, CH7)**

VENDOR	TYPE NO.	CAPACITANCE (μF)	TOLERANCE (%)	SIZE (mm)
Murata	GRM31CB31E106KA75	10.0	10	3.2 × 1.6 × 1.6 (EIA code: 1206)

## CH8 Description

CH8 uses an external FET. It is based on voltage-mode-controlled synchronous boost converter topology used for motor control and an IC inside driver. CH8 output should connect to PS (pin 29) because PS is the path to supply the power for the driver of each channel. This channel has two operation modes – PWM and PFM. The operation depends on the XSLEEP (pin 7) and ENAFE (pin 6) signal level.

When XSLEEP turns high, CH8 operates as PWM mode. The ENAFE signal level does not matter. For start-up (less than 2.5 V at CH8 output), CH8 operates as WAKE mode to use the internal MOSFET switch connected to LL8 (pin 27). The duty cycle of WAKE mode is fixed. After PS voltage reaches 2.5 V, CH8 operation is changed from WAKE mode to PFM mode automatically. PFM mode is driven by the external MOSFET switch. When PS voltage reaches 90% of the target voltage, the operation mode is changed from PFM mode to PWM mode automatically. To operate CH8 in PFM mode only, XSLEEP must be high at first. After that, XSLEEP goes low and ENAFE is high for PFM mode. PFM operation is recommended for the IC drive only from an efficiency point of view.

CH8 has reversed current protection to monitor the different voltage between LL8 and PS. The protection monitors the difference between both PFM mode and PWM mode. When LL8 voltage is larger than PS voltage, the function is activated. When the function is activated, SW8HD (pin 28) level is changed from high to low; SW8LD (pin 26) level stays low. This means that LL8 voltage converges the battery voltage naturally.

The recovery condition is dependent on the operation mode. When CH8 operates as PFM mode, the condition is that FB8 (pin 30) voltage is less than 1.25 V. When CH8 operates as PWM mode, the condition is that LL8 voltage is smaller than PS voltage at the rising edge of the internal clock.

The output voltage is programmable from 3.3 V to 5.5 V to use the feedback loop sensed by the external resistances. The output voltage is calculated by [Equation 9](#). The block diagram is shown in [Figure 11](#).

$$V_{OUT8} = (1 + R1/R2) \times 1.25 \text{ [V]} \quad (9)$$

Where:

$V_{OUT8}$  = Output voltage of CH8 [V]

R1, R2 = Feedback resistance (see [Figure 11](#))



**For IC Inside Driver Only**
**Table 26. Recommended Parts for Inductor (CH8)**

VENDOR	TYPE NO.	INDUCTANCE ( $\mu$ H)	DCR (m $\Omega$ )	SIZE (mm)
Taiyo Yuden	LB2518T330	33	700	1.8 × 2.5 × 1.8

**Table 27. Recommended Parts for Capacitor (Input, CH8)**

VENDOR	TYPE NO.	CAPACITANCE ( $\mu$ F)	TOLERANCE (%)	SIZE (mm)
TDK	C3216X5R0J226M	22	20	3.2 × 1.6 × 0.85 (EIA code: 1206)

**Table 28. Recommended Parts for Capacitor (Output, CH8)**

VENDOR	TYPE NO.	CAPACITANCE ( $\mu$ F)	TOLERANCE (%)	SIZE (mm)
TDK	C1608X5R0J475M	4.7	20	1.6 × 0.8 × 0.8 (EIA code: 0603)

**Table 29. Recommended Parts for FET (CH8)**

VENDOR	TYPE NO.	ID (DC) (N-ch) (A)	ID (DC) (P-ch) (A)	Rds(on) (N-ch) ( $\Omega$ )	Rds(on) (P-ch) ( $\Omega$ )	QG (N-ch) (nQ)	QG (P-ch) (nQ)
ON Semiconductor	NTZD3155C	0.54	–0.43	0.4/4.5 V	0.5 /–4.5 V	1.5	1.7
Sanyo	SCH2615	1.2	–0.9	0.28/4 V	0.47/–4.5 V	1.15	1.43

**Layout Consideration**

To avoid ground shift problems due to the high currents in the switches, separate AGND (pin 10) from PGND1 (pin 20), PGND2 (pin 14), PGND3 (pin 25), PGND4 (pin 2), and PGND5/7 (pin 37). The reference GND for all control signals, such as XSLEEP, is AGND. The power switches inside the IC are connected to PGND1, PGND2, PGND3, PGND4, and PGND5/7. Both grounds must be connected on the printed circuit board (PCB) (ideally at only one point).

**PACKAGING INFORMATION**

Orderable Device	Status (1)	Package Type	Package Drawing	Pins	Package Qty	Eco Plan (2)	Lead/Ball Finish (6)	MSL Peak Temp (3)	Op Temp (°C)	Device Marking (4/5)	Samples
TPS65530ARSLR	ACTIVE	VQFN	RSL	48	2500	Green (RoHS & no Sb/Br)	CU NIPDAU	Level-2-260C-1 YEAR	-25 to 85	TPS 65530A	<a href="#">Samples</a>
TPS65530ARSLT	ACTIVE	VQFN	RSL	48	250	Green (RoHS & no Sb/Br)	CU NIPDAU	Level-2-260C-1 YEAR	-25 to 85	TPS 65530A	<a href="#">Samples</a>

(1) The marketing status values are defined as follows:

**ACTIVE:** Product device recommended for new designs.

**LIFEBUY:** TI has announced that the device will be discontinued, and a lifetime-buy period is in effect.

**NRND:** Not recommended for new designs. Device is in production to support existing customers, but TI does not recommend using this part in a new design.

**PREVIEW:** Device has been announced but is not in production. Samples may or may not be available.

**OBSOLETE:** TI has discontinued the production of the device.

(2) **RoHS:** TI defines "RoHS" to mean semiconductor products that are compliant with the current EU RoHS requirements for all 10 RoHS substances, including the requirement that RoHS substance do not exceed 0.1% by weight in homogeneous materials. Where designed to be soldered at high temperatures, "RoHS" products are suitable for use in specified lead-free processes. TI may reference these types of products as "Pb-Free".

**RoHS Exempt:** TI defines "RoHS Exempt" to mean products that contain lead but are compliant with EU RoHS pursuant to a specific EU RoHS exemption.

**Green:** TI defines "Green" to mean the content of Chlorine (Cl) and Bromine (Br) based flame retardants meet JS709B low halogen requirements of <=1000ppm threshold. Antimony trioxide based flame retardants must also meet the <=1000ppm threshold requirement.

(3) MSL, Peak Temp. - The Moisture Sensitivity Level rating according to the JEDEC industry standard classifications, and peak solder temperature.

(4) There may be additional marking, which relates to the logo, the lot trace code information, or the environmental category on the device.

(5) Multiple Device Markings will be inside parentheses. Only one Device Marking contained in parentheses and separated by a "~" will appear on a device. If a line is indented then it is a continuation of the previous line and the two combined represent the entire Device Marking for that device.

(6) Lead/Ball Finish - Orderable Devices may have multiple material finish options. Finish options are separated by a vertical ruled line. Lead/Ball Finish values may wrap to two lines if the finish value exceeds the maximum column width.

**Important Information and Disclaimer:**The information provided on this page represents TI's knowledge and belief as of the date that it is provided. TI bases its knowledge and belief on information provided by third parties, and makes no representation or warranty as to the accuracy of such information. Efforts are underway to better integrate information from third parties. TI has taken and continues to take reasonable steps to provide representative and accurate information but may not have conducted destructive testing or chemical analysis on incoming materials and chemicals. TI and TI suppliers consider certain information to be proprietary, and thus CAS numbers and other limited information may not be available for release.

In no event shall TI's liability arising out of such information exceed the total purchase price of the TI part(s) at issue in this document sold by TI to Customer on an annual basis.



**TAPE AND REEL INFORMATION**

**QUADRANT ASSIGNMENTS FOR PIN 1 ORIENTATION IN TAPE**

\*All dimensions are nominal

Device	Package Type	Package Drawing	Pins	SPQ	Reel Diameter (mm)	Reel Width W1 (mm)	A0 (mm)	B0 (mm)	K0 (mm)	P1 (mm)	W (mm)	Pin1 Quadrant
TPS65530ARSLR	VQFN	RSL	48	2500	330.0	16.4	6.3	6.3	1.1	12.0	16.0	Q2
TPS65530ARSLR	VQFN	RSL	48	2500	330.0	16.4	6.3	6.3	1.1	12.0	16.0	Q2
TPS65530ARSLT	VQFN	RSL	48	250	180.0	16.4	6.3	6.3	1.1	12.0	16.0	Q2
TPS65530ARSLT	VQFN	RSL	48	250	180.0	16.4	6.3	6.3	1.1	12.0	16.0	Q2

**TAPE AND REEL BOX DIMENSIONS**



\*All dimensions are nominal

Device	Package Type	Package Drawing	Pins	SPQ	Length (mm)	Width (mm)	Height (mm)
TPS65530ARSLR	VQFN	RSL	48	2500	367.0	367.0	38.0
TPS65530ARSLR	VQFN	RSL	48	2500	367.0	367.0	38.0
TPS65530ARSLT	VQFN	RSL	48	250	210.0	185.0	35.0
TPS65530ARSLT	VQFN	RSL	48	250	210.0	185.0	35.0

# MECHANICAL DATA

RSL (S-PVQFN-N48)

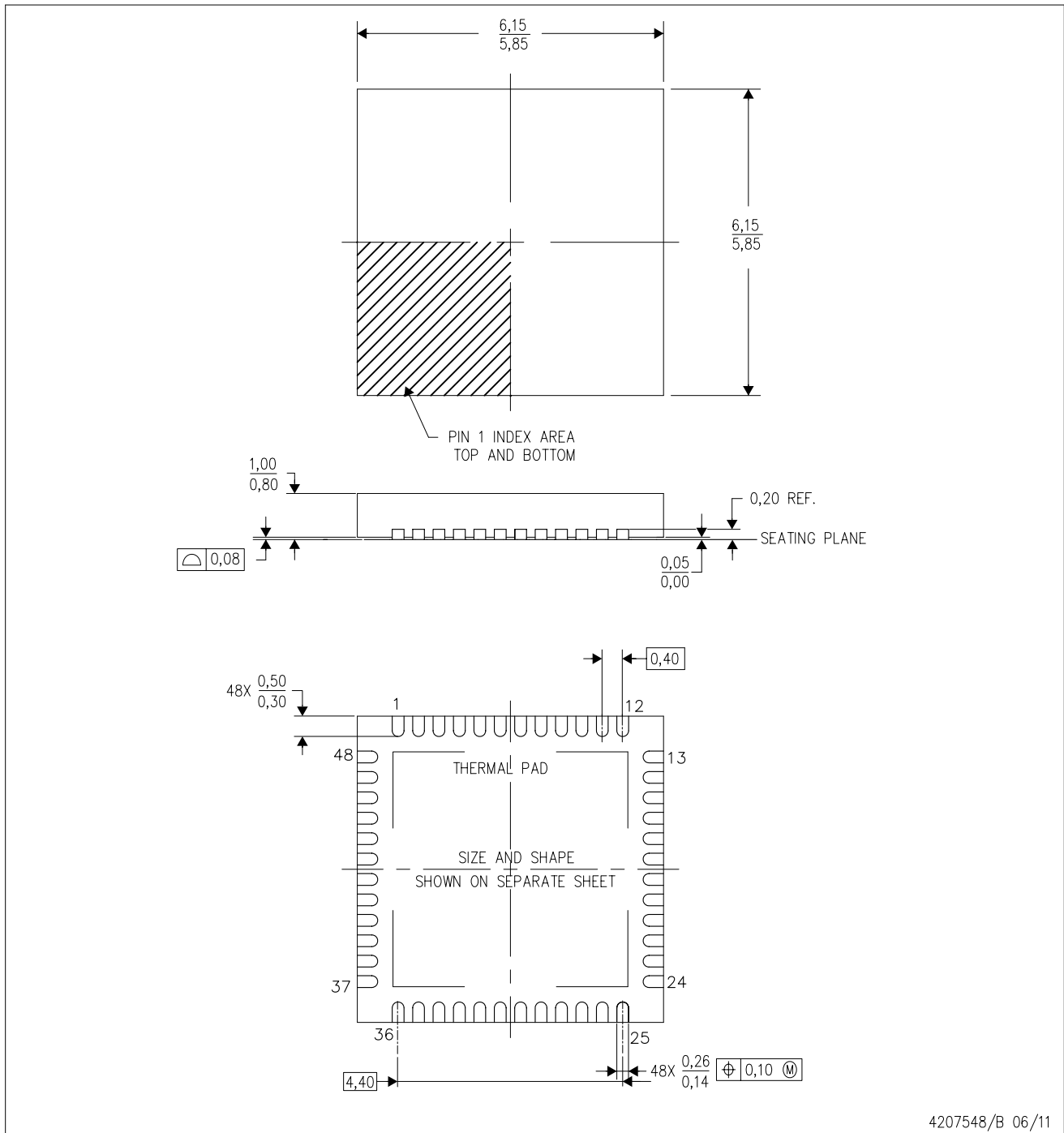
PLASTIC QUAD FLATPACK NO-LEAD



- NOTES:
- A. All linear dimensions are in millimeters. Dimensioning and tolerancing per ASME Y14.5M-1994.
  - B. This drawing is subject to change without notice.
  - C. Quad Flatpack, No-leads (QFN) package configuration.
  - D. The package thermal pad must be soldered to the board for thermal and mechanical performance.
  - E. See the additional figure in the Product Data Sheet for details regarding the exposed thermal pad features and dimensions.

# THERMAL PAD MECHANICAL DATA

RSL (S-PVQFN-N48)

PLASTIC QUAD FLATPACK NO-LEAD

## THERMAL INFORMATION

This package incorporates an exposed thermal pad that is designed to be attached directly to an external heatsink. The thermal pad must be soldered directly to the printed circuit board (PCB). After soldering, the PCB can be used as a heatsink. In addition, through the use of thermal vias, the thermal pad can be attached directly to the appropriate copper plane shown in the electrical schematic for the device, or alternatively, can be attached to a special heatsink structure designed into the PCB. This design optimizes the heat transfer from the integrated circuit (IC).

For information on the Quad Flatpack No-Lead (QFN) package and its advantages, refer to Application Report, QFN/SON PCB Attachment, Texas Instruments Literature No. SLUA271. This document is available at [www.ti.com](http://www.ti.com).

The exposed thermal pad dimensions for this package are shown in the following illustration.

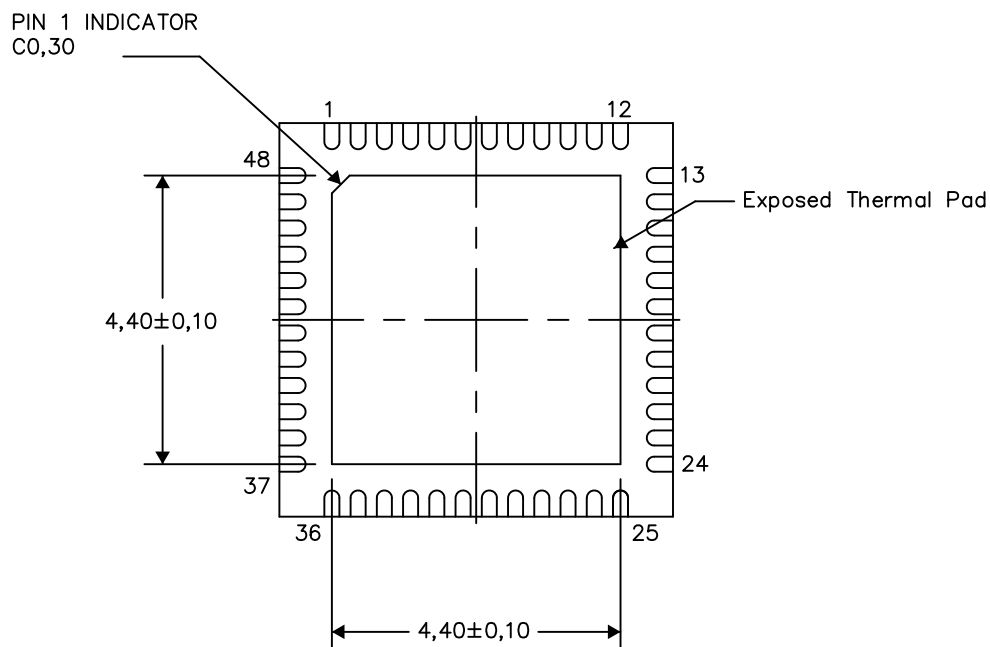

Exposed Thermal Pad Dimensions

4207841-2/P 03/13

NOTE: All linear dimensions are in millimeters

RSL (S-PVQFN-N48)

PLASTIC QUAD FLATPACK NO-LEAD

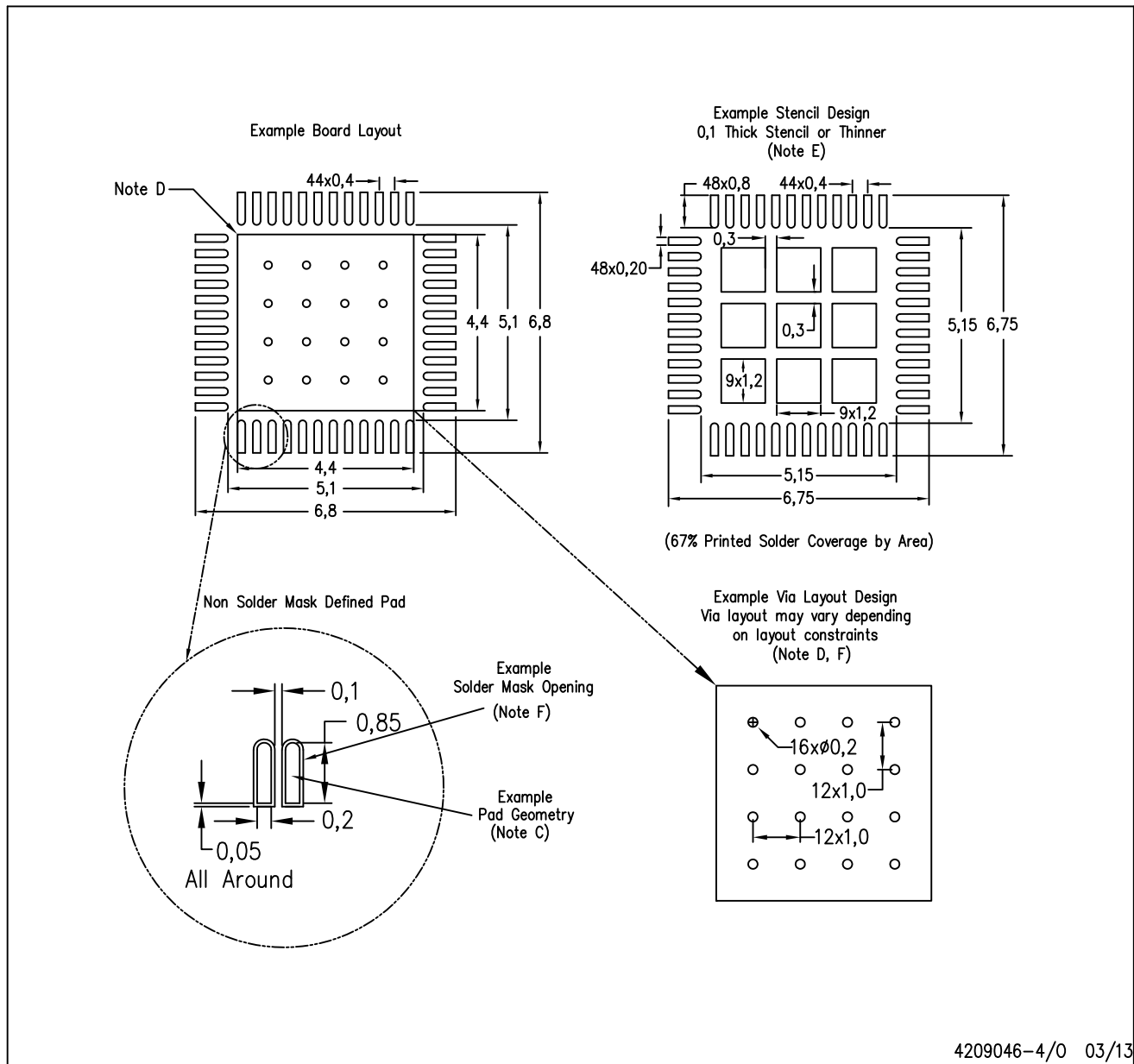

- NOTES:
- A. All linear dimensions are in millimeters.
  - B. This drawing is subject to change without notice.
  - C. Publication IPC-7351 is recommended for alternate designs.
  - D. This package is designed to be soldered to a thermal pad on the board. Refer to Application Note, QFN/SQN PCB Attachment, Texas Instruments Literature No. SLUA271, and also the Product Data Sheets for specific thermal information, via requirements, and recommended board layout. These documents are available at [www.ti.com](http://www.ti.com) <<http://www.ti.com>>.
  - E. Laser cutting apertures with trapezoidal walls and also rounding corners will offer better paste release. Customers should contact their board assembly site for stencil design recommendations. Refer to IPC 7525 for stencil design considerations.
  - F. Customers should contact their board fabrication site for recommended solder mask tolerances and via tenting recommendations for vias placed in the thermal pad.

## IMPORTANT NOTICE

Texas Instruments Incorporated (TI) reserves the right to make corrections, enhancements, improvements and other changes to its semiconductor products and services per JESD46, latest issue, and to discontinue any product or service per JESD48, latest issue. Buyers should obtain the latest relevant information before placing orders and should verify that such information is current and complete.

TI's published terms of sale for semiconductor products (<http://www.ti.com/sc/docs/stdterms.htm>) apply to the sale of packaged integrated circuit products that TI has qualified and released to market. Additional terms may apply to the use or sale of other types of TI products and services.

Reproduction of significant portions of TI information in TI data sheets is permissible only if reproduction is without alteration and is accompanied by all associated warranties, conditions, limitations, and notices. TI is not responsible or liable for such reproduced documentation. Information of third parties may be subject to additional restrictions. Resale of TI products or services with statements different from or beyond the parameters stated by TI for that product or service voids all express and any implied warranties for the associated TI product or service and is an unfair and deceptive business practice. TI is not responsible or liable for any such statements.

Buyers and others who are developing systems that incorporate TI products (collectively, "Designers") understand and agree that Designers remain responsible for using their independent analysis, evaluation and judgment in designing their applications and that Designers have full and exclusive responsibility to assure the safety of Designers' applications and compliance of their applications (and of all TI products used in or for Designers' applications) with all applicable regulations, laws and other applicable requirements. Designer represents that, with respect to their applications, Designer has all the necessary expertise to create and implement safeguards that (1) anticipate dangerous consequences of failures, (2) monitor failures and their consequences, and (3) lessen the likelihood of failures that might cause harm and take appropriate actions. Designer agrees that prior to using or distributing any applications that include TI products, Designer will thoroughly test such applications and the functionality of such TI products as used in such applications.

TI's provision of technical, application or other design advice, quality characterization, reliability data or other services or information, including, but not limited to, reference designs and materials relating to evaluation modules, (collectively, "TI Resources") are intended to assist designers who are developing applications that incorporate TI products; by downloading, accessing or using TI Resources in any way, Designer (individually or, if Designer is acting on behalf of a company, Designer's company) agrees to use any particular TI Resource solely for this purpose and subject to the terms of this Notice.

TI's provision of TI Resources does not expand or otherwise alter TI's applicable published warranties or warranty disclaimers for TI products, and no additional obligations or liabilities arise from TI providing such TI Resources. TI reserves the right to make corrections, enhancements, improvements and other changes to its TI Resources. TI has not conducted any testing other than that specifically described in the published documentation for a particular TI Resource.

Designer is authorized to use, copy and modify any individual TI Resource only in connection with the development of applications that include the TI product(s) identified in such TI Resource. NO OTHER LICENSE, EXPRESS OR IMPLIED, BY ESTOPPEL OR OTHERWISE TO ANY OTHER TI INTELLECTUAL PROPERTY RIGHT, AND NO LICENSE TO ANY TECHNOLOGY OR INTELLECTUAL PROPERTY RIGHT OF TI OR ANY THIRD PARTY IS GRANTED HEREIN, including but not limited to any patent right, copyright, mask work right, or other intellectual property right relating to any combination, machine, or process in which TI products or services are used. Information regarding or referencing third-party products or services does not constitute a license to use such products or services, or a warranty or endorsement thereof. Use of TI Resources may require a license from a third party under the patents or other intellectual property of the third party, or a license from TI under the patents or other intellectual property of TI.

TI RESOURCES ARE PROVIDED "AS IS" AND WITH ALL FAULTS. TI DISCLAIMS ALL OTHER WARRANTIES OR REPRESENTATIONS, EXPRESS OR IMPLIED, REGARDING RESOURCES OR USE THEREOF, INCLUDING BUT NOT LIMITED TO ACCURACY OR COMPLETENESS, TITLE, ANY EPIDEMIC FAILURE WARRANTY AND ANY IMPLIED WARRANTIES OF MERCHANTABILITY, FITNESS FOR A PARTICULAR PURPOSE, AND NON-INFRINGEMENT OF ANY THIRD PARTY INTELLECTUAL PROPERTY RIGHTS. TI SHALL NOT BE LIABLE FOR AND SHALL NOT DEFEND OR INDEMNIFY DESIGNER AGAINST ANY CLAIM, INCLUDING BUT NOT LIMITED TO ANY INFRINGEMENT CLAIM THAT RELATES TO OR IS BASED ON ANY COMBINATION OF PRODUCTS EVEN IF DESCRIBED IN TI RESOURCES OR OTHERWISE. IN NO EVENT SHALL TI BE LIABLE FOR ANY ACTUAL, DIRECT, SPECIAL, COLLATERAL, INDIRECT, PUNITIVE, INCIDENTAL, CONSEQUENTIAL OR EXEMPLARY DAMAGES IN CONNECTION WITH OR ARISING OUT OF TI RESOURCES OR USE THEREOF, AND REGARDLESS OF WHETHER TI HAS BEEN ADVISED OF THE POSSIBILITY OF SUCH DAMAGES.

Unless TI has explicitly designated an individual product as meeting the requirements of a particular industry standard (e.g., ISO/TS 16949 and ISO 26262), TI is not responsible for any failure to meet such industry standard requirements.

Where TI specifically promotes products as facilitating functional safety or as compliant with industry functional safety standards, such products are intended to help enable customers to design and create their own applications that meet applicable functional safety standards and requirements. Using products in an application does not by itself establish any safety features in the application. Designers must ensure compliance with safety-related requirements and standards applicable to their applications. Designer may not use any TI products in life-critical medical equipment unless authorized officers of the parties have executed a special contract specifically governing such use. Life-critical medical equipment is medical equipment where failure of such equipment would cause serious bodily injury or death (e.g., life support, pacemakers, defibrillators, heart pumps, neurostimulators, and implantables). Such equipment includes, without limitation, all medical devices identified by the U.S. Food and Drug Administration as Class III devices and equivalent classifications outside the U.S.

TI may expressly designate certain products as completing a particular qualification (e.g., Q100, Military Grade, or Enhanced Product). Designers agree that it has the necessary expertise to select the product with the appropriate qualification designation for their applications and that proper product selection is at Designers' own risk. Designers are solely responsible for compliance with all legal and regulatory requirements in connection with such selection.

Designer will fully indemnify TI and its representatives against any damages, costs, losses, and/or liabilities arising out of Designer's non-compliance with the terms and provisions of this Notice.

## Looking for pricing, stock, or lifecycle information?

Click below to explore more details on WIN SOURCE:

 [View TPS65530ARSLT on WIN SOURCE](#)

 [Texas Instruments](#) Information

## Optimize Your Supply Chain with WIN SOURCE Solutions

-  Global Sourcing Solution
-  Obsolete Management
-  Cost Control Management
-  Shortage Management
-  Alternative Solution
-  Excess Inventory Management