



**THE DATASHEET OF
STSJ100NHS3LL**





STSJ100NHS3LL

N-channel 30V - 0.0032Ω - 20A - PowerSO-8™
STripFET™III Power MOSFET plus monolithic schottky

General features

Type	V _{DSS}	R _{DS(on)}	I _D
STSJ100NHS3LL	30V	0.0042Ω	20A ⁽¹⁾

1. This value is rated accordingly to R_{thj-pcb}

- Optimal R_{DS(on)} x Q_g trade-off @ 4.5V
- Reduced switching losses
- Reduced conduction losses
- Improved junction-case thermal resistance

Description

This product utilizes the latest advanced design rules of ST's proprietary STripFET™ technology and a proprietary process for integrating a monolithic schottky diode. The new Power MOSFET is optimized for the most demanding synchronous switch function in DC-DC converter for Computer and Telecom.

Applications

- Switching application

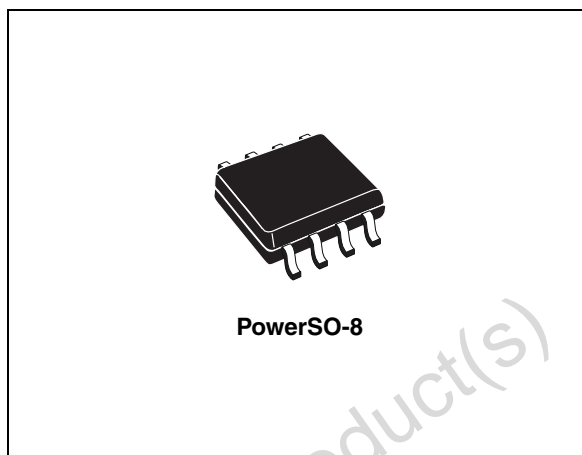

PowerSO-8

Internal schematic diagram

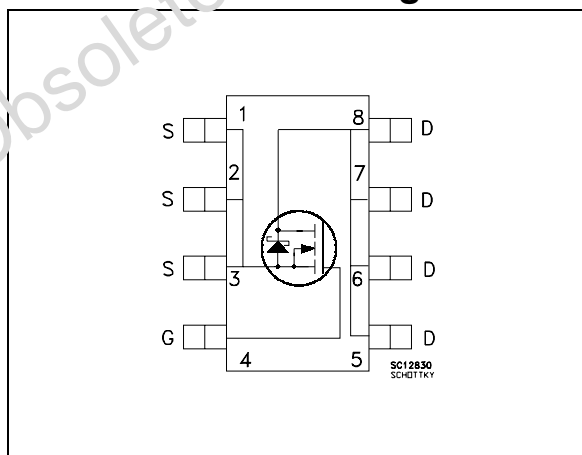

Order codes

Part number	Marking	Package	Packaging
STSJ100NHS3LL	100HS3L-	PowerSO-8	Tape & reel

Contents

1	Electrical ratings	4
2	Electrical characteristics	6
2.1	Electrical characteristics (curves)	8
3	Test circuit	11
4	Package mechanical data	12
5	Revision history	14

Obsolete Product(s) - Obsolete Product(s)

1 Electrical ratings

Table 1. Absolute maximum ratings

Symbol	Parameter	Value	Unit
V_{DS}	Drain-source voltage ($V_{GS} = 0$)	30	V
V_{GS}	Gate-source voltage	± 16	V
$I_D^{(1)}$	Drain current (continuous) at $T_C = 25^\circ\text{C}$	20	A
$I_D^{(2)}$	Drain current (continuous) at $T_C = 25^\circ\text{C}$	100	A
I_D	Drain current (continuous) at $T_C = 100^\circ\text{C}$	12.6	A
$I_{DM}^{(3)}$	Drain current (pulsed)	80	A
P_{TOT}	Total dissipation at $T_C = 25^\circ\text{C}^{(2)}$	70	W
	Total dissipation at $T_C = 25^\circ\text{C}^{(1)}$	3	W
T_J	Operating junction temperature	-55 to 150	$^\circ\text{C}$
T_{stg}	Storage temperature		

1. This value is rated accordingly to $R_{thj-pcb}$
2. This value is rated according to R_{thj-c}
3. Pulse width limited by safe operating area

Table 2. Thermal data

Symbol	Parameter	Value	Unit
R_{thj-c}	Thermal resistance junction-case max	1.8	$^\circ\text{C/W}$
$R_{thj-pcb}^{(1)}$	Thermal resistance junction-pcb max	42	$^\circ\text{C/W}$

1. When mounted on 1 inch² FR-4 board, 2oz Cu ($t < 10\text{sec.}$)

Table 3. Avalanche data

Symbol	Parameter	Value	Unit
I_{AV}	Avalanche current, not repetitive (pulse width limited by T_{jmax})	10	A
E_{AS}	Single pulse avalanche energy (starting $T_j = 25^\circ\text{C}$, $I_D = I_{AV}$, $V_{DD} = 24\text{V}$)	1.8	J

2 Electrical characteristics

($T_{CASE}=25^{\circ}C$ unless otherwise specified)

Table 4. On/off states

Symbol	Parameter	Test conditions	Min.	Typ.	Max.	Unit
$V_{(BR)DSS}$	Drain-source breakdown voltage	$I_D = 1mA, V_{GS} = 0$	30			V
I_{DSS}	Zero gate voltage drain current ($V_{GS} = 0$)	$V_{DS} = 24V$			500	μA
I_{GSS}	Gate body leakage current ($V_{DS} = 0$)	$V_{GS} = \pm 16V$			± 100	nA
$V_{GS(th)}$	Gate threshold voltage	$V_{DS} = V_{GS}, I_D = 1mA$	1		2.5	V
$R_{DS(on)}$	Static drain-source on resistance	$V_{GS} = 10V, I_D = 10A$		0.0032	0.0042	Ω
		$V_{GS} = 4.5V, I_D = 10A$		0.004	0.0057	Ω
$R_{DS(on)}$	Static drain-source on resistance	$V_{GS} = 10V, I_D = 10A @ 125^{\circ}C$		0.005		Ω
		$V_{GS} = 4.5V, I_D = 10A @ 125^{\circ}C$		0.006		Ω

Table 5. Dynamic

Symbol	Parameter	Test conditions	Min.	Typ.	Max.	Unit
$g_{fs}^{(1)}$	Forward transconductance	$V_{DS} = 10V, I_D = 15A$		44		S
C_{iss}	Input capacitance	$V_{DS} = 25V, f = 1MHz, V_{GS} = 0$		4200		pF
C_{oss}	Output capacitance			700		pF
C_{rss}	Reverse transfer capacitance			46.2		pF
Q_g	Total gate charge	$V_{DD} = 15V, I_D = 20A$		27	35	nC
Q_{gs}	Gate-source charge	$V_{GS} = 4.5V,$		8.5		nC
Q_{gd}	Gate-drain charge	(see Figure 13)		7.2		nC

1. Pulsed: pulse duration=300 μs , duty cycle 1.5%

Table 6. Switching times

Symbol	Parameter	Test conditions	Min.	Typ.	Max.	Unit
$t_{d(on)}$ t_r	Turn-on delay time Rise time	$V_{DD}=15V, I_D=10A,$ $R_G=4.7\Omega, V_{GS}=4.5V$ <i>(see Figure 12)</i>		16 45		ns ns
$t_{d(off)}$ t_f	Turn-off delay time Fall time	$V_{DD}=15V, I_D=10A,$ $R_G=4.7\Omega, V_{GS}=4.5V$ <i>(see Figure 12)</i>		68 8		ns ns

Table 7. Source drain diode

Symbol	Parameter	Test conditions	Min.	Typ.	Max.	Unit
I_{SD} $I_{SDM}^{(1)}$	Source-drain current Source-drain current (pulsed)				20 80	A A
$V_{SD}^{(2)}$	Forward on voltage	$I_{SD}=5A, V_{GS}=0$			0.75	V
t_{rr} Q_{rr} I_{RRM}	Reverse recovery time Reverse recovery charge Reverse recovery current	$I_{SD}=20A, di/dt = 100A/\mu s,$ $V_{DD}=25V, T_j=150^\circ C$ <i>(see Figure 17)</i>		30 30 2		ns nC A

1. Pulse width limited by safe operating area
2. Pulsed: pulse duration=300μs, duty cycle 1.5%

2.1 Electrical characteristics (curves)

Figure 1. Safe operating area

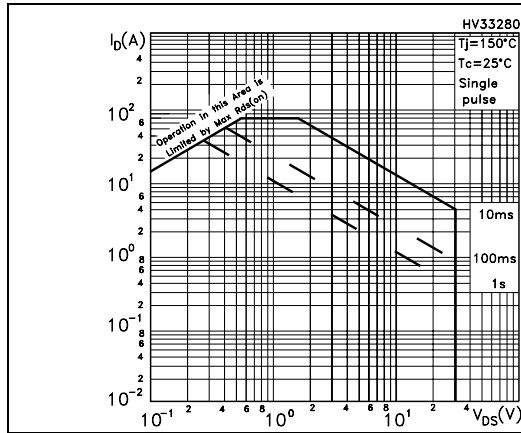

Figure 2. Thermal impedance

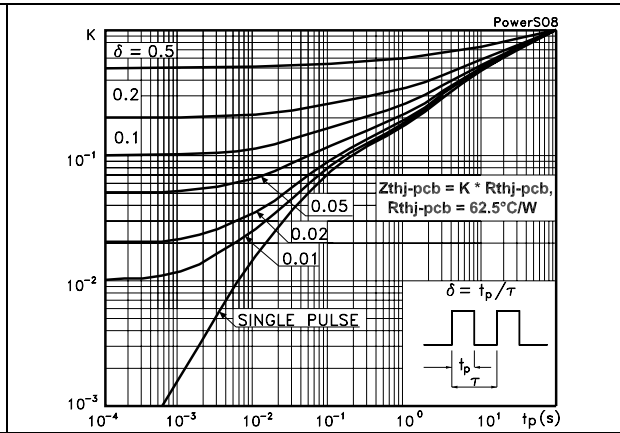

Figure 3. Output characteristics

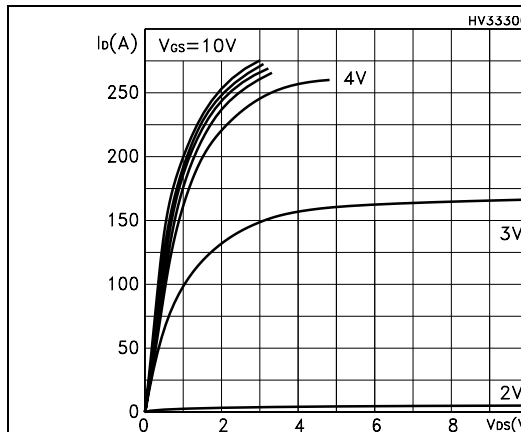

Figure 4. Transfer characteristics

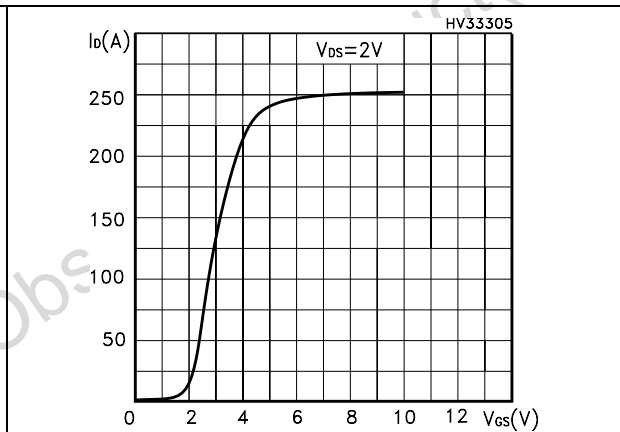

Figure 5. Normalized $B_{V_{DS}}$ vs temperature

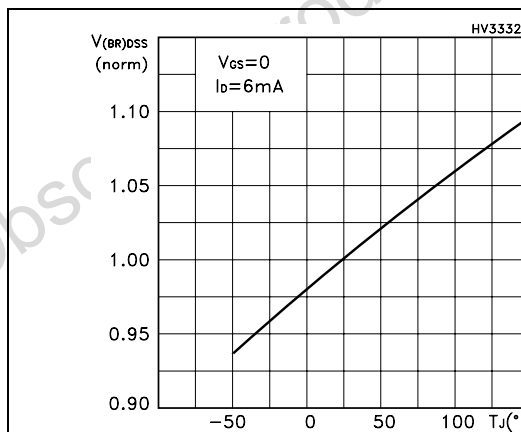

Figure 6. Static drain-source on resistance

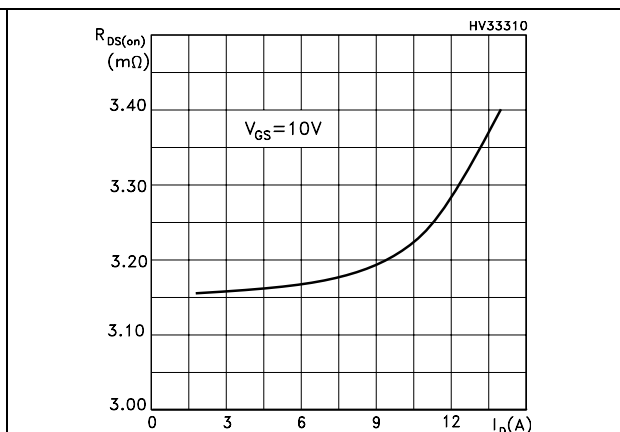

Figure 7. Gate charge vs gate-source voltage Figure 8. Capacitance variations

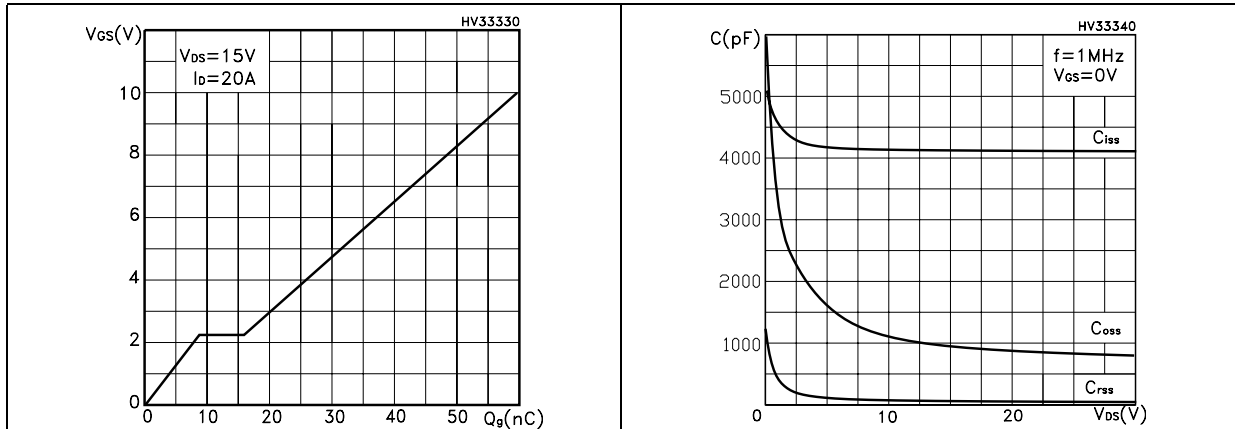

Figure 9. Normalized gate threshold voltage vs temperature Figure 10. Normalized on resistance vs temperature

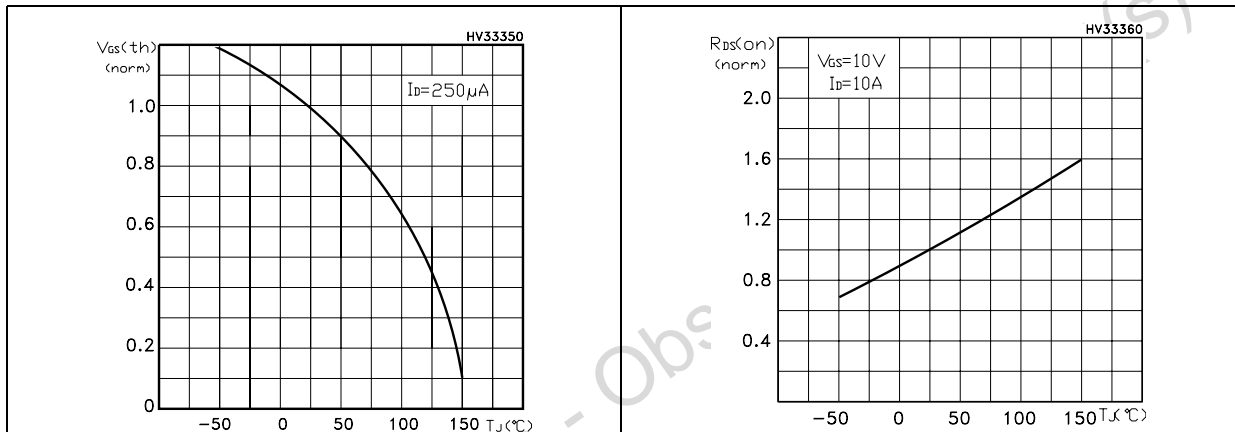
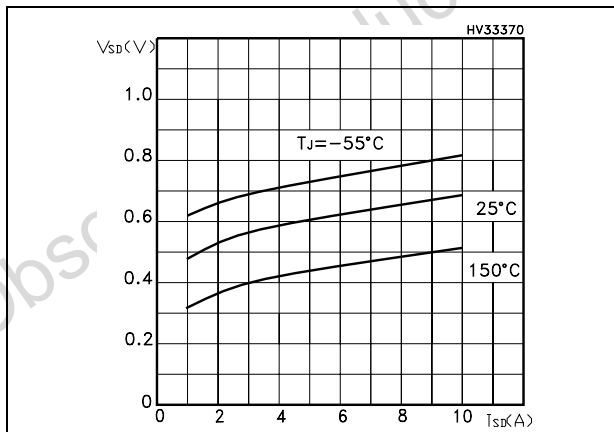

Figure 11. Source-drain diode forward characteristics



3 Test circuit

Figure 12. Switching times test circuit for resistive load

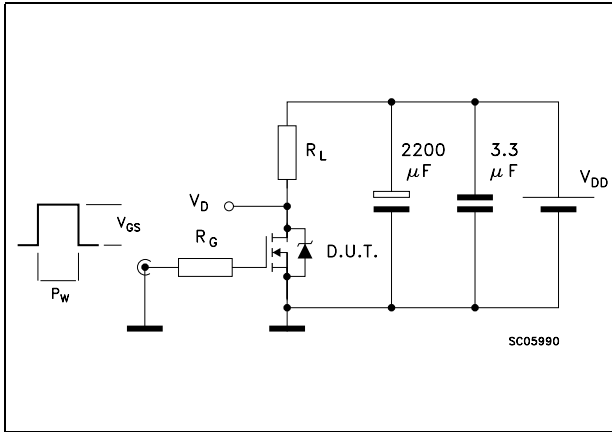

Figure 13. Gate charge test circuit

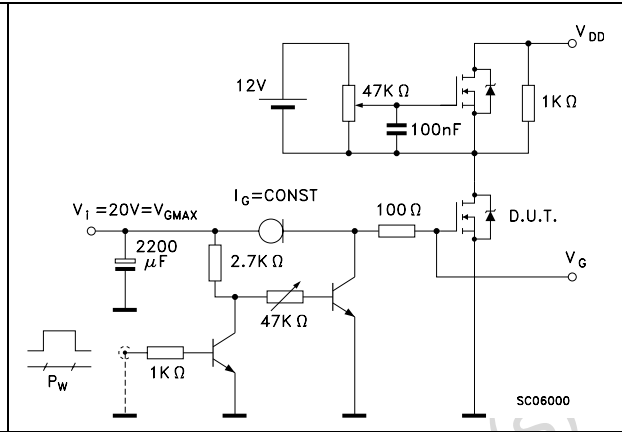

Figure 14. Test circuit for inductive load switching and diode recovery times

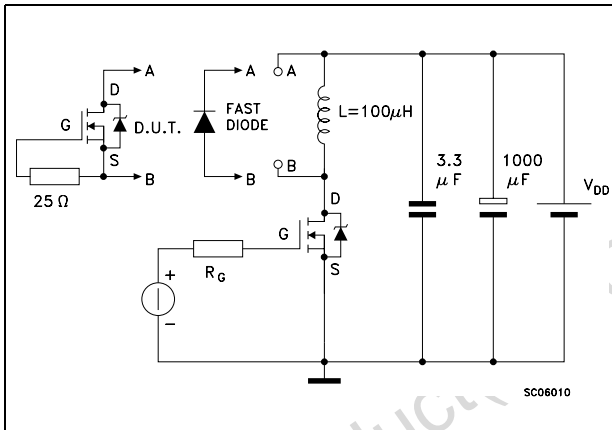

Figure 15. Unclamped inductive load test circuit

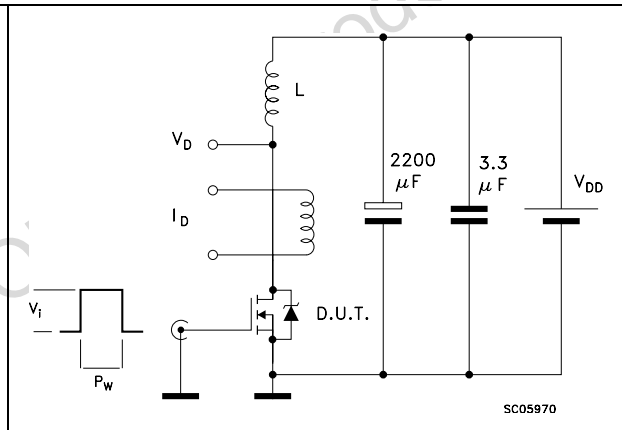

Figure 16. Unclamped inductive waveform

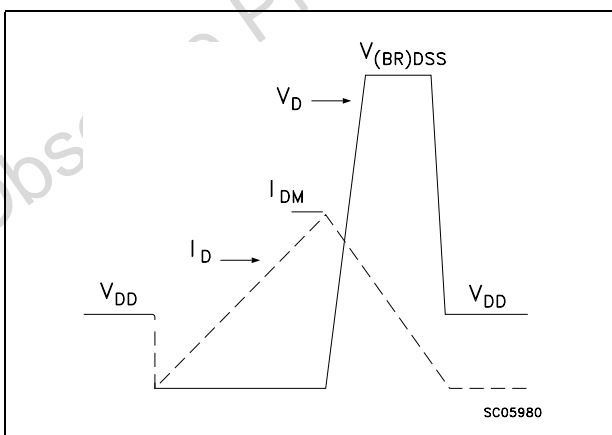
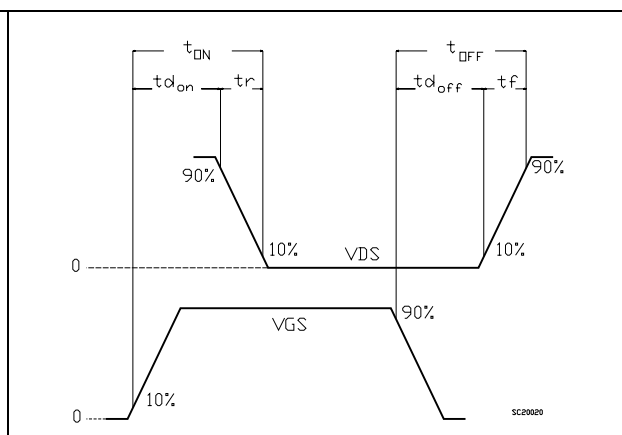

Figure 17. Switching time waveform



4 Package mechanical data

In order to meet environmental requirements, ST offers these devices in ECOPACK® packages. These packages have a Lead-free second level interconnect . The category of second level interconnect is marked on the package and on the inner box label, in compliance with JEDEC Standard JESD97. The maximum ratings related to soldering conditions are also marked on the inner box label. ECOPACK is an ST trademark. ECOPACK specifications are available at : www.st.com

Obsolete Product(s) - Obsolete Product(s)

PowerSO-8™ MECHANICAL DATA

DIM.	mm.			inch		
	MIN.	TYP.	MAX.	MIN.	TYP.	MAX.
A			1.75			0.068
a1	0.1		0.25	0.003		0.009
a2			1.65			0.064
a3	0.65		0.85	0.025		0.033
b	0.35		0.48	0.013		0.018
b1	0.19		0.25	0.007		0.010
C	0.25		0.5	0.010		0.019
c1	45° (typ.)					
D	4.8		5.0	0.188		0.196
E	5.8		6.2	0.228		0.244
e		1.27			0.050	
e3		3.81			0.150	
e4		2.79			0.110	
F	3.8		4.0	0.14		0.157
L	0.4		1.27	0.015		0.050
M			0.6			0.023
S	8° (max.)					

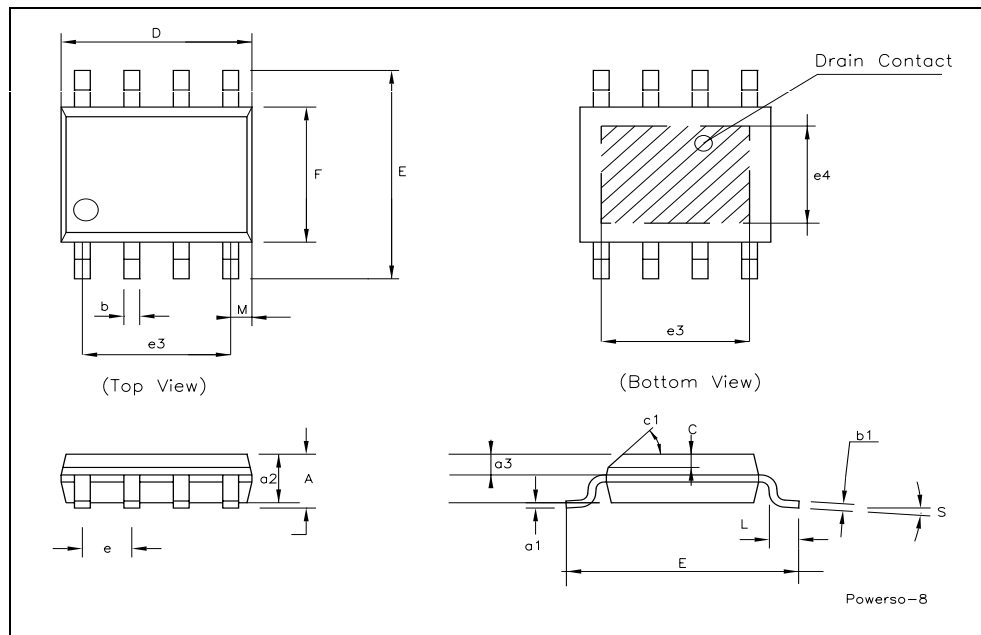

5 Revision history

Table 8. Revision history

Date	Revision	Changes
13-Jan-2006	1	Initial release.
24-Jan-2006	2	Changed unit on Table 7: Source drain diode
18-Jul-2006	3	Complete version

Obsolete Product(s) - Obsolete Product(s)

Please Read Carefully:

Information in this document is provided solely in connection with ST products. STMicroelectronics NV and its subsidiaries ("ST") reserve the right to make changes, corrections, modifications or improvements, to this document, and the products and services described herein at any time, without notice.

All ST products are sold pursuant to ST's terms and conditions of sale.

Purchasers are solely responsible for the choice, selection and use of the ST products and services described herein, and ST assumes no liability whatsoever relating to the choice, selection or use of the ST products and services described herein.

No license, express or implied, by estoppel or otherwise, to any intellectual property rights is granted under this document. If any part of this document refers to any third party products or services it shall not be deemed a license grant by ST for the use of such third party products or services, or any intellectual property contained therein or considered as a warranty covering the use in any manner whatsoever of such third party products or services or any intellectual property contained therein.

UNLESS OTHERWISE SET FORTH IN ST'S TERMS AND CONDITIONS OF SALE ST DISCLAIMS ANY EXPRESS OR IMPLIED WARRANTY WITH RESPECT TO THE USE AND/OR SALE OF ST PRODUCTS INCLUDING WITHOUT LIMITATION IMPLIED WARRANTIES OF MERCHANTABILITY, FITNESS FOR A PARTICULAR PURPOSE (AND THEIR EQUIVALENTS UNDER THE LAWS OF ANY JURISDICTION), OR INFRINGEMENT OF ANY PATENT, COPYRIGHT OR OTHER INTELLECTUAL PROPERTY RIGHT.

UNLESS EXPRESSLY APPROVED IN WRITING BY AN AUTHORIZED ST REPRESENTATIVE, ST PRODUCTS ARE NOT RECOMMENDED, AUTHORIZED OR WARRANTED FOR USE IN MILITARY, AIR CRAFT, SPACE, LIFE SAVING, OR LIFE SUSTAINING APPLICATIONS, NOR IN PRODUCTS OR SYSTEMS WHERE FAILURE OR MALFUNCTION MAY RESULT IN PERSONAL INJURY, DEATH, OR SEVERE PROPERTY OR ENVIRONMENTAL DAMAGE. ST PRODUCTS WHICH ARE NOT SPECIFIED AS "AUTOMOTIVE GRADE" MAY ONLY BE USED IN AUTOMOTIVE APPLICATIONS AT USER'S OWN RISK.

Resale of ST products with provisions different from the statements and/or technical features set forth in this document shall immediately void any warranty granted by ST for the ST product or service described herein and shall not create or extend in any manner whatsoever, any liability of ST.

ST and the ST logo are trademarks or registered trademarks of ST in various countries.

Information in this document supersedes and replaces all information previously supplied.

The ST logo is a registered trademark of STMicroelectronics. All other names are the property of their respective owners.

© 2006 STMicroelectronics - All rights reserved



STMicroelectronics group of companies

Australia - Belgium - Brazil - Canada - China - Czech Republic - Finland - France - Germany - Hong Kong - India - Israel - Italy - Japan - Malaysia - Malta - Morocco - Singapore - Spain - Sweden - Switzerland - United Kingdom - United States of America

www.st.com

Looking for pricing, stock, or lifecycle information?

Click below to explore more details on WIN SOURCE:

-  [View STSJ100NHS3LL on WIN SOURCE](#)
-  [STMicroelectronics](#) Information

Optimize Your Supply Chain with WIN SOURCE Solutions

-  Global Sourcing Solution
-  Obsolete Management
-  Cost Control Management
-  Shortage Management
-  Alternative Solution
-  Excess Inventory Management