

SL5500

SL5501

SL5504

SL5511

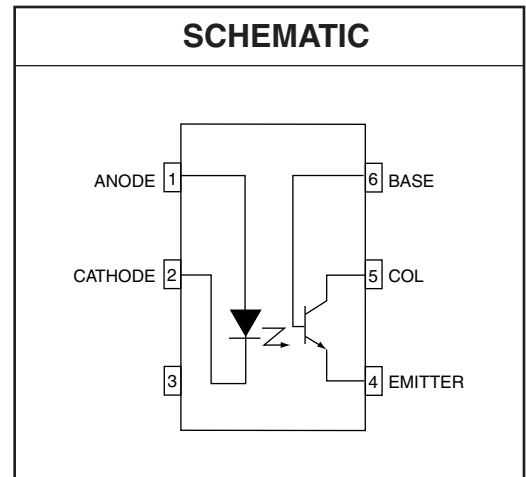
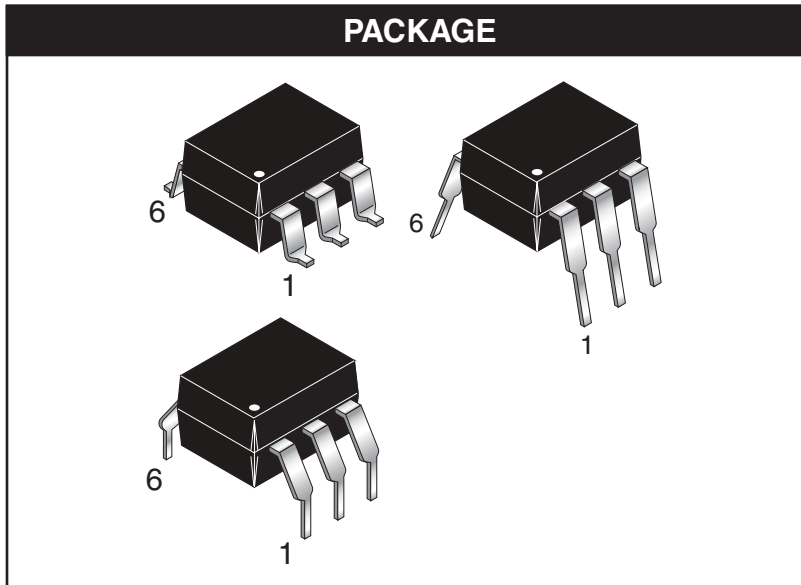

DESCRIPTION

The SL5500, SL5501, SL5504 and SL5511 are optically coupled isolators each consisting of an infrared emitting GaAs diode and a silicon NPN phototransistor with accessible base. These devices are housed in 6-pin dual-in-line packages (DIP).

FEATURES

- High output/input DC current transfer ratio
- Low saturation voltage
- High isolation voltage of 5.3 kV RMS
- UL recognized (File # E90700)
- VDE recognized (File # 94766)
- Ordering option '300' (e.g. SL5500.300)

APPLICATIONS

- Power supply regulators
- Digital logic inputs
- Microprocessor inputs
- Appliance sensor systems
- Industrial controls

SL5500

SL5501

SL5504

SL5511

| Parameters | | Symbol | Value | Units |
|--|------------------------|------------------|----------------|-------|
| TOTAL DEVICE | | | | |
| Storage Temperature | | T_{STG} | -55 to +150 | °C |
| Operating Temperature | | T_{OPR} | -55 to +100 | °C |
| Lead Solder Temperature | | T_{SOL} | 260 for 10 sec | °C |
| Total Power Dissipation at $T_A = 25^\circ\text{C}$ Ambient Derate Linearly from 25°C | | P_D | 260 | mW |
| | | | 3.3 | mW/°C |
| EMITTER | | | | |
| Continuous Reverse Voltage | | V_R | 3 | V |
| Continuous Forward Current | | I_F | 100 | mA |
| Forward Current - Peak (10 μs pulse, $\delta = 0.01$) | | $I_F(\text{pk})$ | 3.0 | A |
| Total Power Dissipation $T_A = 25^\circ\text{C}$ Ambient Derate Linearly from 25°C | | P_D | 150 | mW |
| | | | 2.0 | mW/°C |
| DETECTOR | | | | |
| Collector to Emitter Voltage (open base) | SL5500, SL5501, SL5511 | V_{CEO} | 30 | V |
| | SL5504 | | 80 | |
| Collector to Base Voltage (open emitter) | SL5500, SL5501, SL5511 | V_{CBO} | 70 | V |
| | SL5504 | | 120 | |
| Emitter to Collector Voltage (open base) | | V_{ECO} | 7 | V |
| Emitter to Base Voltage (open collector) | | V_{EBO} | 7 | V |
| DC Collector Current | | I_C | 100 | mA |
| Detector Power Dissipation @ $T_A = 25^\circ\text{C}$ Ambient Derate Linearly from 25°C | | P_D | 150 | mW |
| | | | 2.0 | mW/°C |

SL5500

SL5501

SL5504

SL5511

ELECTRICAL CHARACTERISTICS ($T_A = 25^\circ\text{C}$ Unless otherwise specified.)

INDIVIDUAL COMPONENT CHARACTERISTICS

| Parameters | Test Conditions | Symbol | Device | Min | Typ* | Max | Units |
|---|---|------------|------------------------|-----|-------|-----|---------------|
| EMITTER | | | | | | | |
| Input Forward Voltage | $I_F = 20\text{ mA}, T_A = 25\text{ to }70^\circ\text{C}$ | V_F | All | | 1.23 | 1.3 | V |
| | $I_F = 2\text{ mA}$ | | | | 1.10 | 1.2 | V |
| Reverse Current | $V_R = 3\text{ V}, T_A = 25\text{ to }70^\circ\text{C}$ | I_R | All | | 0.001 | 10 | μA |
| DETECTOR | | | | | | | |
| Leakage Current Collector to Emitter | $V_{CE} = 10\text{ V}$ | I_{CEO} | All | | 1 | 50 | nA |
| | $V_{CE} = 30\text{ V}$ | | | | 0.005 | 10 | μA |
| | $V_{CE} = 10\text{ V}, T_A = 70^\circ\text{C}$ | | | | | 500 | nA |
| | $V_{CB} = 30\text{ V}$ | I_{CBO} | | | 0.001 | 50 | μA |
| Breakdown Voltage | | | | | | | |
| Collector to Emitter | $I_C = 10\text{ }\mu\text{A}, I_F = 0$ | BV_{CEO} | SL5500, SL5501, SL5511 | 30 | 100 | | V |
| | | | SL5504 | 80 | 110 | | |
| Collector to Base | $I_C = 10\text{ }\mu\text{A}, I_F = 0$ | BV_{CBO} | SL5500, SL5501, SL5511 | 30 | 120 | | V |
| | | | SL5504 | 120 | 150 | | |
| Emitter to Collector | $I_E = 10\text{ }\mu\text{A}, I_F = 0$ | BV_{ECO} | All | 7 | 10 | | V |
| Emitter to Base | $I_E = 10\text{ }\mu\text{A}, I_F = 0$ | BV_{EBO} | All | 7 | 10 | | V |

ISOLATION CHARACTERISTICS

| Characteristic | Test Conditions | Symbol | Min | Typ* | Max | Units |
|---|---------------------------------------|-----------|------|------|-----|---------------|
| Input-Output Isolation Voltage (note 1) | $f = 60\text{ Hz}, T = 1\text{ min.}$ | V_{ISO} | 5300 | | | $V_{AC(RMS)}$ |
| Isolation Resistance | $V_{I-O} = \pm 500\text{ VDC}$ | R_{ISO} | 1 | 10 | | $T\Omega$ |
| Isolation Capacitance | $f = 1\text{ MHz}, V = 0\text{ V}$ | C_{ISO} | | 0.6 | 1.3 | pF |

*Typical values at $T_A = 25^\circ\text{C}$

SL5500

SL5501

SL5504

SL5511

TRANSFER CHARACTERISTICS (TA = 25°C Unless otherwise specified.)

| DC Characteristics | Test Conditions | Symbol | Device | Min | Typ | Max | Units |
|--------------------------------------|---|---------------|------------------------|-----|-----|-----|---------------|
| Output/Input Current Transfer Ratio | $I_F = 10 \text{ mA}, V_{CE} = 0.4 \text{ V}$ | CTR | SL5500 | 50 | | 300 | % |
| | $I_F = 10 \text{ mA}, V_{CE} = 0.4 \text{ V}, T_A = 70^\circ\text{C}$ | | SL5500 | 40 | | 300 | |
| | $I_F = 10 \text{ mA}, V_{CE} = 0.4 \text{ V}, T_A = 25^\circ\text{C to } 70^\circ\text{C}$ | | SL5501, SL5504 | 25 | | 400 | |
| | $I_F = 2 \text{ mA}, V_{CE} = 5 \text{ V}$ | | SL5500 | 40 | | | |
| | $I_F = 2 \text{ mA}, V_{CE} = 5 \text{ V}, T_A = 70^\circ\text{C}$ | | SL5500 | 30 | | | |
| | $I_F = 2 \text{ mA}, V_{CE} = 5 \text{ V}, T_A = 25^\circ\text{C to } 70^\circ\text{C}$ | | SL5501, SL5504 | 15 | | | |
| | $I_F = 2 \text{ mA}, V_{CE} = 5 \text{ V}, T_A = 25^\circ\text{C to } 70^\circ\text{C}$ | | SL5511 | 25 | | | |
| | $I_F = 0.5 \text{ mA}, V_{CE} = 0.4 \text{ V}, T_A = 25^\circ\text{C to } 70^\circ\text{C}$ | | SL5511 | 20 | | | |
| Collector-Emitter Saturation Voltage | $I_F = 50 \text{ mA}, I_C = 10 \text{ mA}$ | $V_{CE(SAT)}$ | SL5500 | | | 0.4 | V |
| | $I_F = 20 \text{ mA}, I_C = 2 \text{ mA}$ | | SL5501, SL5504, SL5511 | | | 0.4 | |
| AC Characteristics | Test Conditions | Symbol | Device | Min | Typ | Max | Units |
| Turn-On Time | $R_L = 1 \text{ k}\Omega, I_F = 16 \text{ mA}, V_{CC} = 5 \text{ V}$ | t_{on} | SL5500, SL5501, SL5511 | | | 20 | μs |
| | | | SL5504 | | | 50 | |
| Turn-Off Time | See Fig. 1 and Fig. 2 | t_{off} | SL5500, SL5501, SL5511 | | | 50 | μs |
| | | | SL5504 | | | 150 | |

Note

1. Device considered a two-terminal device: pins 1, 2 and 3 shorted together and pins 4, 5 and 6 shorted together.

SL5500

SL5501

SL5504

SL5511

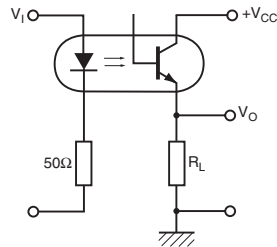

Fig. 1 Switching Circuit

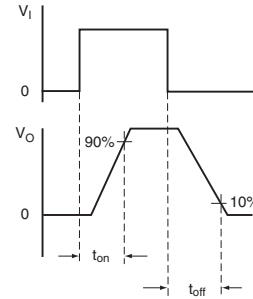

Fig. 2 Waveforms

Fig. 3 LED Forward Voltage vs. Forward Current

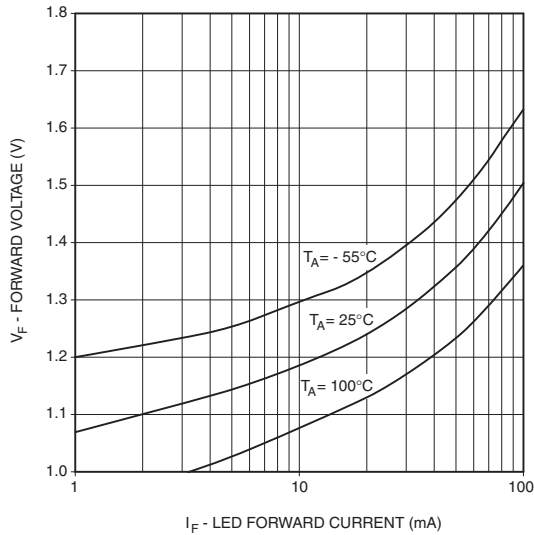

Fig. 4 Normalized CTR vs. Forward Current

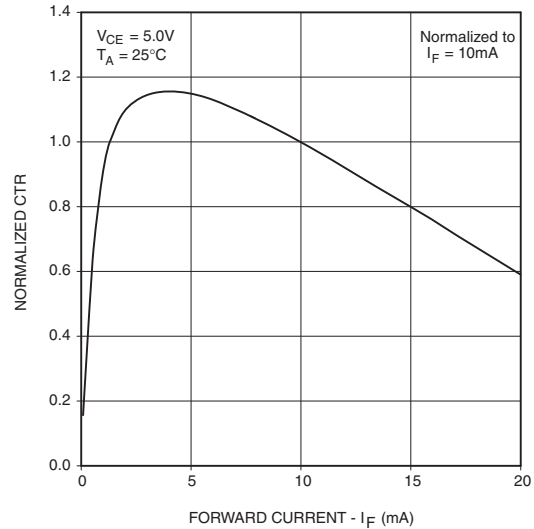

Fig. 5 Normalized CTR vs. Ambient Temperature

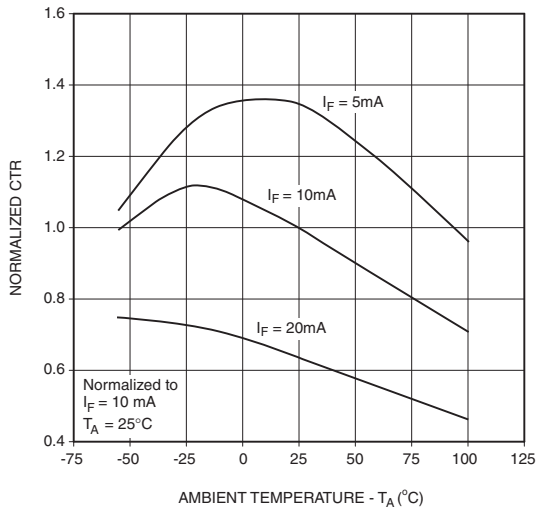
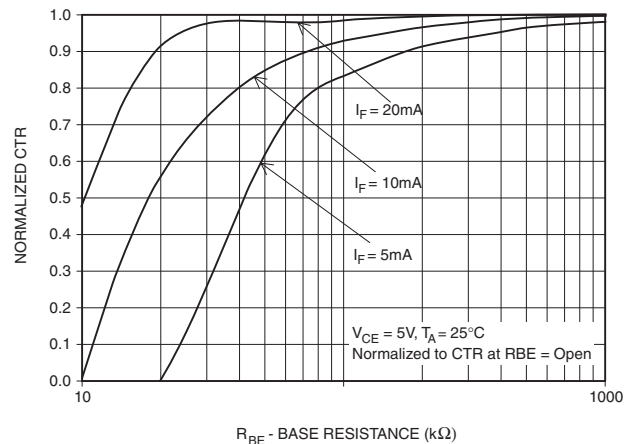

Fig. 7 CTR vs. R_{BE} (Unsaturated)



SL5500

SL5501

SL5504

SL5511

Fig. 7 CTR vs. R_{BE} (Saturated)

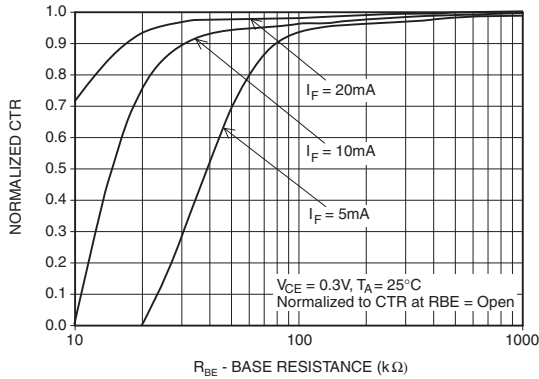

Fig. 8 Normalized t_{off} vs. R_{BE}

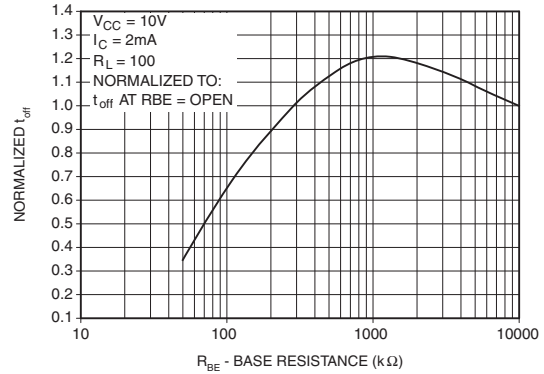

Fig. 9 Normalized t_{on} vs. R_{BE}

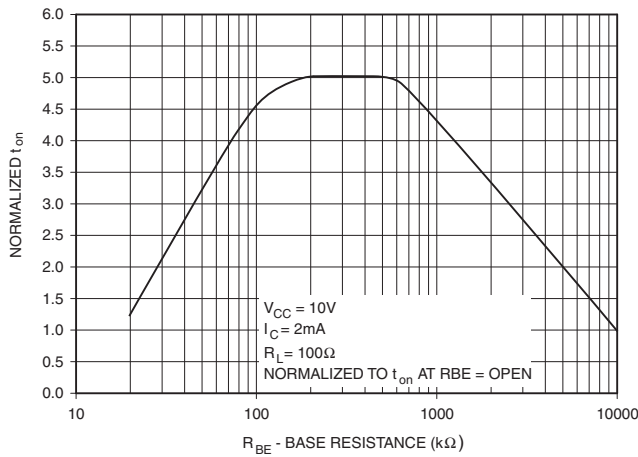

Fig. 10 Switching Speed vs. Load Resistor

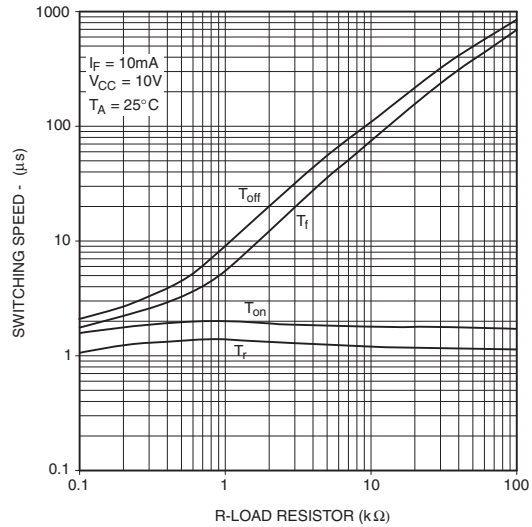

Fig. 11 Collector Emitter Saturation Voltage vs. Collector Current

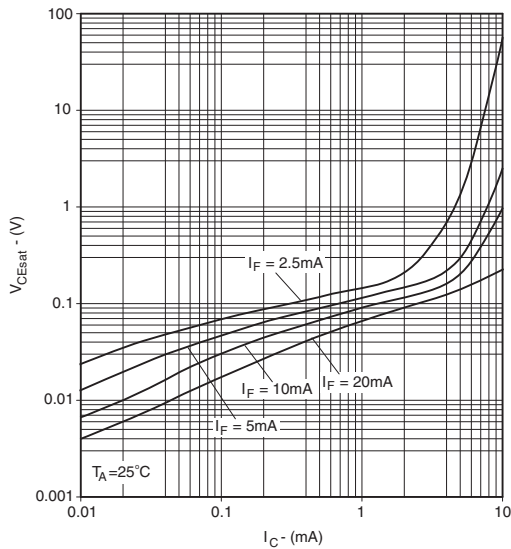
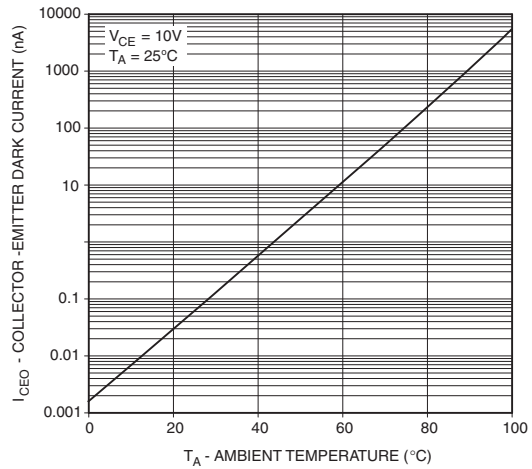

Fig. 12 Dark Current vs. Ambient Temperature



SL5500

SL5501

SL5504

SL5511

Package Dimensions (Through Hole)

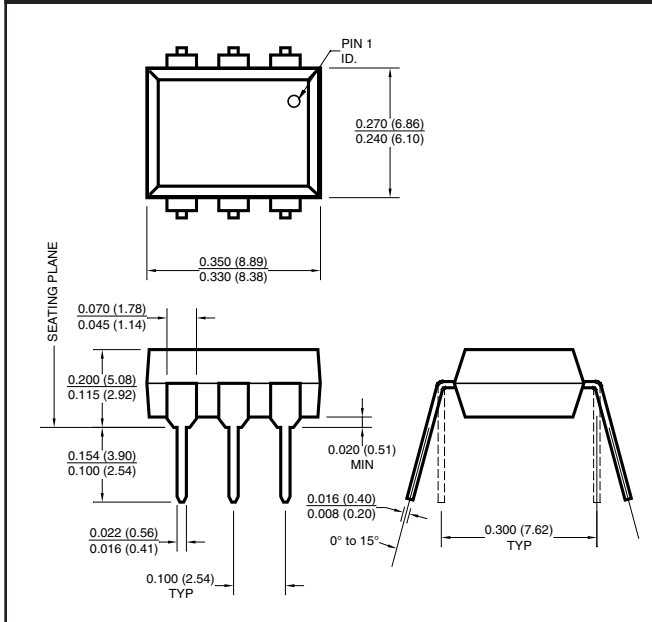

Package Dimensions (Surface Mount)

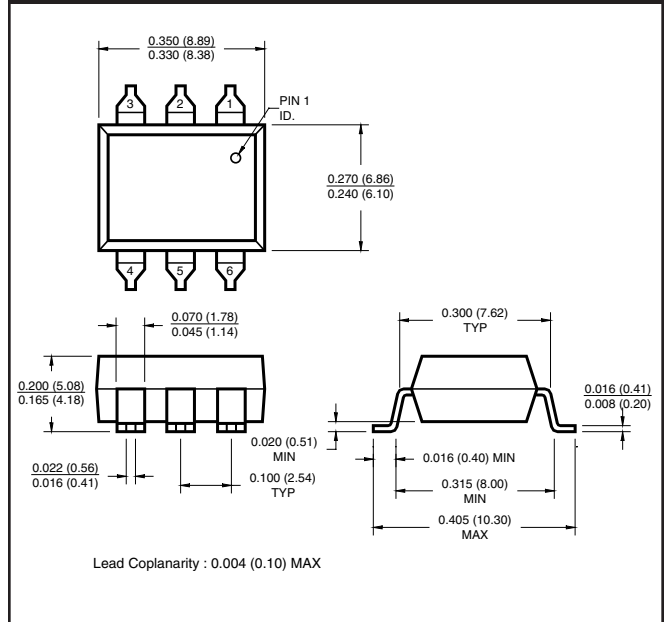

Package Dimensions (0.4" Lead Spacing)

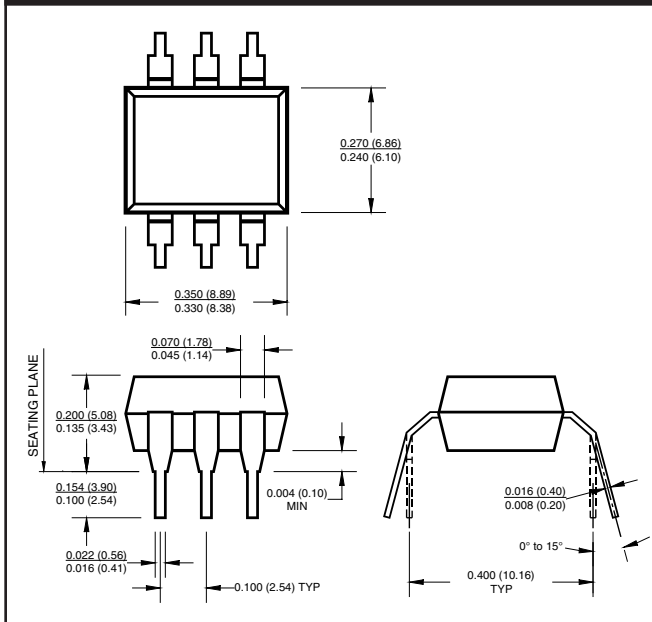

**Recommended Pad Layout for
Surface Mount Leadform**

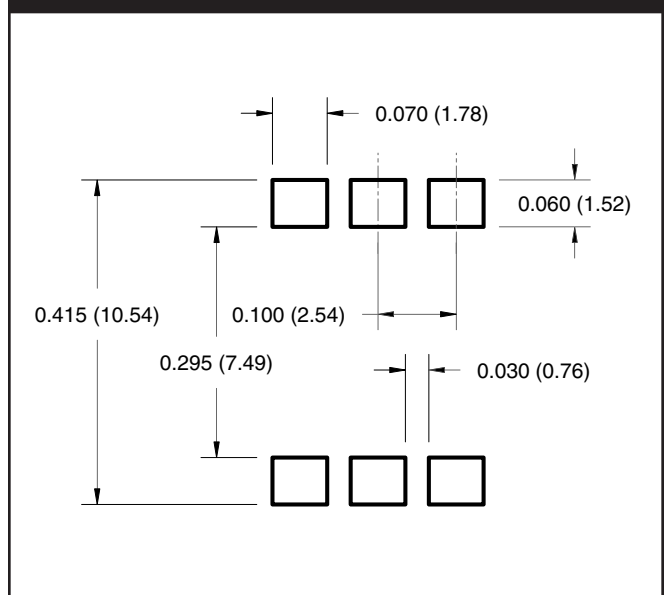

Note

All dimensions are in inches (millimeters)

SL5500

SL5501

SL5504

SL5511

ORDERING INFORMATION

| Option | Order Entry Identifier | Description |
|--------|------------------------|--|
| S | .S | Surface Mount Lead Bend |
| SD | .SD | Surface Mount; Tape and Reel |
| W | .W | 0.4" Lead Spacing |
| 300 | .300 | VDE 0884 |
| 300W | .300W | VDE 0884, 0.4" Lead Spacing |
| 3S | .3S | VDE 0884, Surface Mount |
| 3SD | .3SD | VDE 0884, Surface Mount, Tape and Reel |

MARKING INFORMATION

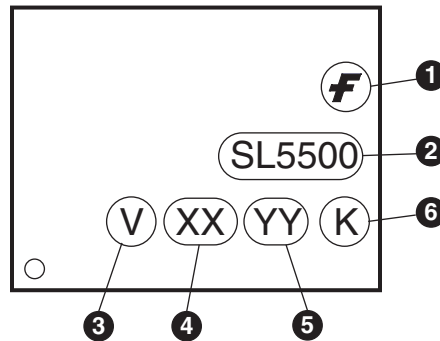

| Definitions | |
|-------------|--|
| 1 | Fairchild logo |
| 2 | Device number |
| 3 | VDE mark (Note: Only appears on parts ordered with VDE option – See order entry table) |
| 4 | Two digit year code, e.g., '03' |
| 5 | Two digit work week ranging from '01' to '53' |
| 6 | Assembly package code |

SL5500

SL5501

SL5504

SL5511

Carrier Tape Specifications (“D” Taping Orientation)

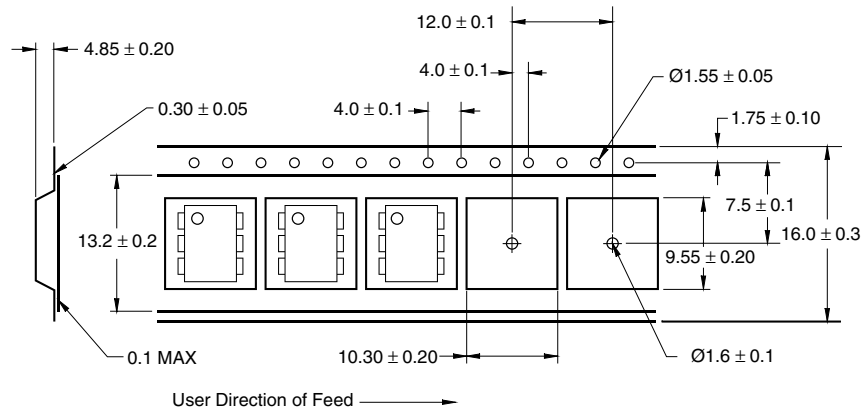

NOTE

All dimensions are in inches (millimeters)

Reflow Profile (Black Package, No Suffix)

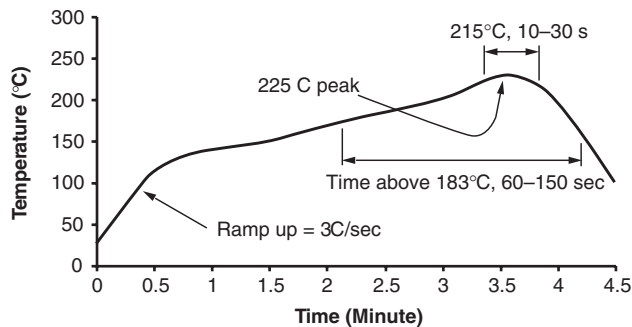

- Peak reflow temperature: 225°C (package surface temperature)
- Time of temperature higher than 183°C for 60–150 seconds
- One time soldering reflow is recommended

SL5500

SL5501

SL5504

SL5511

DISCLAIMER

FAIRCHILD SEMICONDUCTOR RESERVES THE RIGHT TO MAKE CHANGES WITHOUT FURTHER NOTICE TO ANY PRODUCTS HEREIN TO IMPROVE RELIABILITY, FUNCTION OR DESIGN. FAIRCHILD DOES NOT ASSUME ANY LIABILITY ARISING OUT OF THE APPLICATION OR USE OF ANY PRODUCT OR CIRCUIT DESCRIBED HEREIN; NEITHER DOES IT CONVEY ANY LICENSE UNDER ITS PATENT RIGHTS, NOR THE RIGHTS OF OTHERS.

LIFE SUPPORT POLICY

FAIRCHILD'S PRODUCTS ARE NOT AUTHORIZED FOR USE AS CRITICAL COMPONENTS IN LIFE SUPPORT DEVICES OR SYSTEMS WITHOUT THE EXPRESS WRITTEN APPROVAL OF THE PRESIDENT OF FAIRCHILD SEMICONDUCTOR CORPORATION. As used herein:

1. Life support devices or systems are devices or systems which, (a) are intended for surgical implant into the body, or (b) support or sustain life, and (c) whose failure to perform when properly used in accordance with instructions for use provided in the labeling, can be reasonably expected to result in a significant injury of the user.
2. A critical component in any component of a life support device or system whose failure to perform can be reasonably expected to cause the failure of the life support device or system, or to affect its safety or effectiveness.

Looking for pricing, stock, or lifecycle information?

Click below to explore more details on WIN SOURCE:

- ⊖ [View SL5500SD on WIN SOURCE](#)
- ⊖ [Fairchild/ON Semiconductor Information](#)

Optimize Your Supply Chain with WIN SOURCE Solutions

- ✓ Global Sourcing Solution
- ✓ Obsolete Management
- ✓ Cost Control Management
- ✓ Shortage Management
- ✓ Alternative Solution
- ✓ Excess Inventory Management