



THE DATASHEET OF STGB35N35LZT4



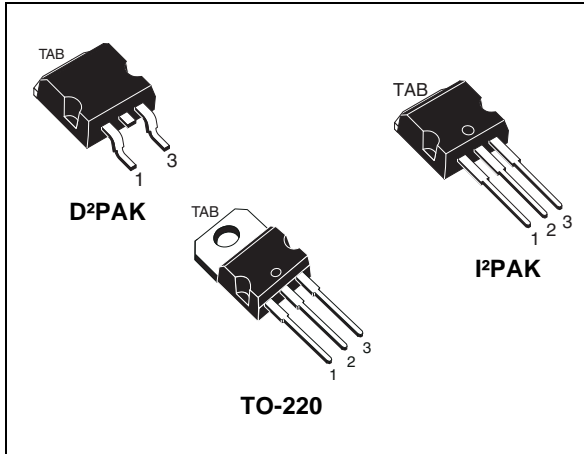
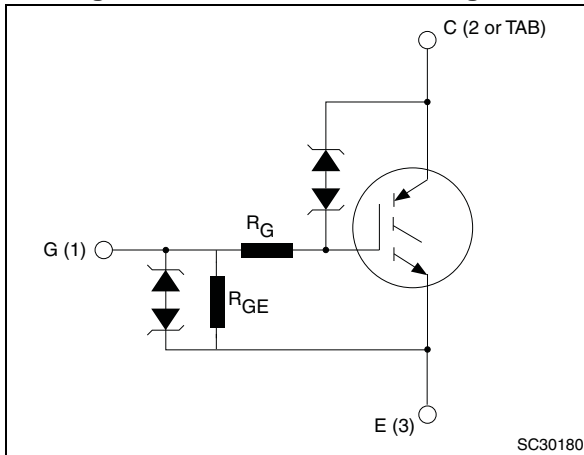

Figure 1. Internal schematic diagram



Features

- Designed for automotive applications and AEC-Q101 qualified
- Low threshold voltage
- Low on-voltage drop
- High voltage clamping feature
- Logic level gate charge
- ESD gate-emitter protection
- Gate and gate-emitter integrated resistors

Application

- Automotive ignition

Description

This application specific IGBT utilizes the most advanced PowerMESH™ technology. The built-in Zener diodes between gate-collector and gate-emitter provide overvoltage protection capabilities. The device also exhibits low on-state voltage drop and low threshold drive for use in automotive ignition system.

Table 1. Device summary

Order codes	Marking	Package	Packaging
STGB35N35LZ-1	GB35N35LZ	I ² PAK	Tube
STGB35N35LZT4	GB35N35LZ	D ² PAK	Tape and reel
STGP35N35LZ	GP35N35LZ	TO-220	Tube

Contents

1	Electrical ratings	3
2	Electrical characteristics	4
2.1	Electrical characteristics (curves)	6
3	Test circuits	9
4	Package mechanical data	10
5	Packaging mechanical data	15
6	Revision history	17



1 Electrical ratings

Table 2. Absolute maximum ratings

Symbol	Parameter	Value	Unit
V_{CES}	Collector-emitter voltage ($V_{GE} = 0$)	V_{CES} (clamped)	V
V_{ECS}	Emitter collector voltage ($V_{GE} = 0$)	20	V
$I_C^{(1)}$	Continuous collector current at $T_C = 25\text{ °C}$	40	A
$I_C^{(1)}$	Continuous collector current at $T_C = 100\text{ °C}$	30	A
$I_{CP}^{(2)}$	Pulsed collector current	80	A
V_{GE}	Gate-emitter voltage	V_{GE} (clamped)	V
P_{TOT}	Total dissipation at $T_C = 25\text{ °C}$	176	W
E_{AS}	Single pulse energy ($T_C=25\text{ °C}$, $L=1.6\text{ mH}$, $I_C = 22\text{ A}$, $V_{CC} = 50\text{ V}$)	450	mJ
ESD	Human body model ($R=1,5\text{ k}\Omega$, $C=100\text{ pF}$)	8	kV
	Machine model ($R=0$, $C=100\text{ pF}$)	800	V
	Charged device model	2	kV
T_{stg}	Storage temperature	- 55 to 175	°C
T_j	Operating junction temperature		

1. Calculated according to the iterative formula:

$$I_C(T_C) = \frac{T_{j(max)} - T_C}{R_{thj-c} \times V_{CE(sat)(max)}(T_{j(max)}, I_C(T_C))}$$

2. Pulse width limited by maximum junction temperature

Table 3. Thermal data

Symbol	Parameter	Value	Unit
$R_{thj-case}$	Thermal resistance junction-case	0.85	°C/W
$R_{thj-amb}$	Thermal resistance junction-ambient	62.5	°C/W

2 Electrical characteristics

($T_j = 25\text{ °C}$ unless otherwise specified)

Table 4. Static

Symbol	Parameter	Test conditions	Min.	Typ.	Max.	Unit
$V_{CES(\text{clamped})}$	Collector emitter clamped voltage ($V_{GE}=0$)	$I_C=2\text{ mA}$,		345		V
		$I_C=2\text{ mA}$, $T_j = -40\text{ °C to }150\text{ °C}$	320		380	V
$V_{(BR)ECS}$	Emitter collector break-down voltage ($V_{GE}=0$)	$I_C = 75\text{ mA}$	20	28		V
$V_{GE(\text{clamped})}$	Gate emitter clamped voltage	$I_G = \pm 2\text{ mA}$	12	14	16	V
I_{CES}	Collector cut-off current ($V_{GE} = 0$)	$V_{CE} = 15\text{ V}$, $T_j = 150\text{ °C}$			10	μA
		$V_{CE} = 200\text{ V}$, $T_j = 150\text{ °C}$			100	μA
I_{GES}	Gate-emitter leakage current ($V_{CE} = 0$)	$V_{GE} = \pm 10\text{ V}$	500	625	830	μA
R_{GE}	Gate emitter resistance		12	15	20	$\text{k}\Omega$
R_G	Gate resistance			1.5		$\text{k}\Omega$
$V_{GE(\text{th})}$	Gate threshold voltage	$V_{CE} = V_{GE}$, $I_C = 1\text{ mA}$, $T_j = -40\text{ °C}$	1.4			V
		$V_{CE} = V_{GE}$, $I_C = 1\text{ mA}$	1.2	1.6	2.3	V
		$V_{CE} = V_{GE}$, $I_C = 1\text{ mA}$, $T_j = 150\text{ °C}$	0.7			V
$V_{CE(\text{sat})}$	Collector-emitter saturation voltage	$V_{GE} = 4.5\text{ V}$, $I_C = 10\text{ A}$		1.15	1.5	V
		$V_{GE} = 4.5\text{ V}$, $I_C = 15\text{ A}$		1.3	1.7	V

Table 5. Dynamic

Symbol	Parameter	Test conditions	Min.	Typ.	Max.	Unit
C_{ies}	Input capacitance	$V_{CE} = 25\text{ V}$, $f = 1\text{ MHz}$, $V_{GE} = 0$	-	700	-	pF
C_{oes}	Output capacitance		-	150	-	pF
C_{res}	Reverse transfer capacitance		-	6	-	pF
Q_g	Gate charge	$V_{CE} = 280\text{ V}$, $I_C = 15\text{ A}$, $V_{GE} = 5\text{ V}$	-	49	-	nC

Table 6. Functional characteristics

Symbol	Parameter	Test conditions	Min.	Typ.	Max.	Unit
U.I.S.	Functional test open secondary coil	$R_G = 0$, $T_j = 150\text{ °C}$, $V_{CC} = 50\text{ V}$, $V_{GE} = 5\text{ V}$, $L = 1.6\text{ mH}$	18	-	-	A

Table 7. Switching time

Symbol	Parameter	Test conditions	Min.	Typ.	Max.	Unit
$t_{d(on)}$ t_r	Resistive load	$V_{CC} = 14\text{ V}$, $R_L = 1\ \Omega$, $V_{GE} = 5\text{ V}$	-	1.1	-	μs
	Turn-on delay time					μs
	Rise time					μs
$t_{d(on)}$ t_r	Resistive load	$V_{CC} = 14\text{ V}$, $R_L = 1\ \Omega$, $V_{GE} = 5\text{ V}$ $T_j = 150\text{ °C}$	-	1	-	μs
	Turn-on delay time					μs
	Rise time					μs
$t_{d(off)}$ t_f dv/dt	Inductive load	$V_{CC} = 300\text{ V}$, $L = 1\text{ mH}$ $I_C = 15\text{ A}$, $V_{GE} = 5\text{ V}$	-	26.5	-	μs
	Turn-off delay time					μs
	Fall time					μs
$t_{d(off)}$ t_f dv/dt	Inductive load	$V_{CC} = 300\text{ V}$, $L = 1\text{ mH}$ $I_C = 15\text{ A}$, $V_{GE} = 5\text{ V}$ $T_j = 150\text{ °C}$	-	28	-	μs
	Turn-off delay time					μs
	Fall time					μs
$t_{d(off)}$ t_f dv/dt	Inductive load	$V_{CC} = 300\text{ V}$, $L = 1\text{ mH}$ $I_C = 15\text{ A}$, $V_{GE} = 5\text{ V}$ $T_j = 150\text{ °C}$	-	9	-	μs
	Turn-off delay time					μs
	Fall time					μs
$t_{d(off)}$ t_f dv/dt	Inductive load	$V_{CC} = 300\text{ V}$, $L = 1\text{ mH}$ $I_C = 15\text{ A}$, $V_{GE} = 5\text{ V}$ $T_j = 150\text{ °C}$	-	65	-	μs
	Turn-off delay time					μs
	Fall time					μs
$t_{d(off)}$ t_f dv/dt	Inductive load	$V_{CC} = 300\text{ V}$, $L = 1\text{ mH}$ $I_C = 15\text{ A}$, $V_{GE} = 5\text{ V}$ $T_j = 150\text{ °C}$	-	65	-	μs
	Turn-off delay time					μs
	Fall time					μs

2.1 Electrical characteristics (curves)

Figure 2. Collector-emitter saturation voltage vs temperature

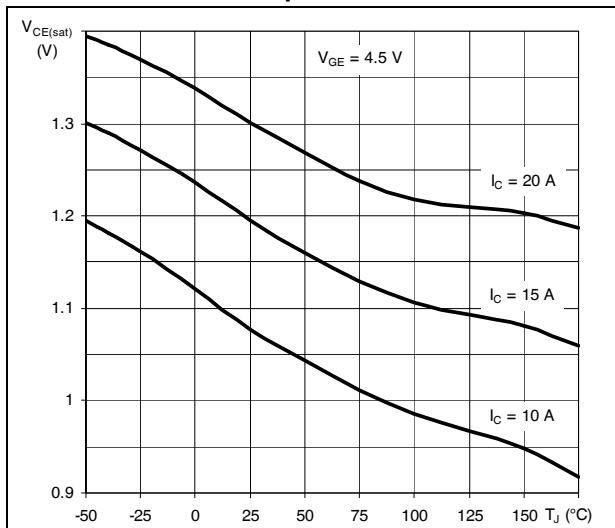

Figure 3. Self clamped inductive switch

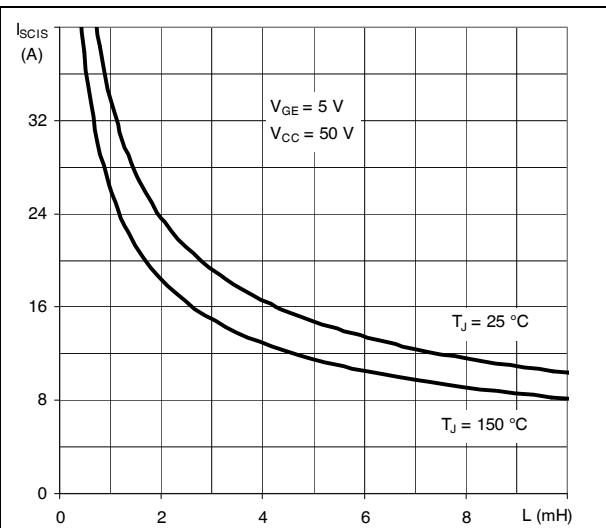

Figure 4. Output characteristics ($T_J = 25^{\circ}C$)

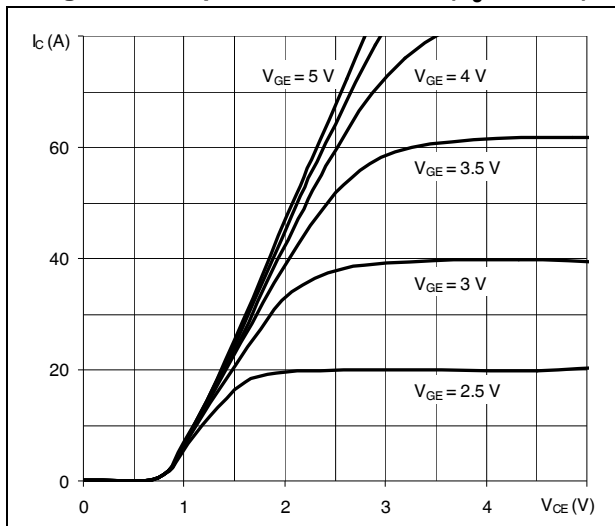

Figure 5. Output characteristics ($T_J = -40^{\circ}C$)

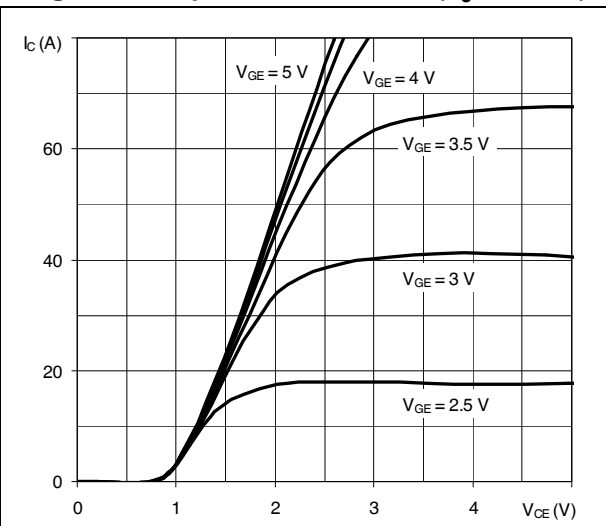

Figure 6. Output characteristics ($T_J = 175\text{ }^\circ\text{C}$)

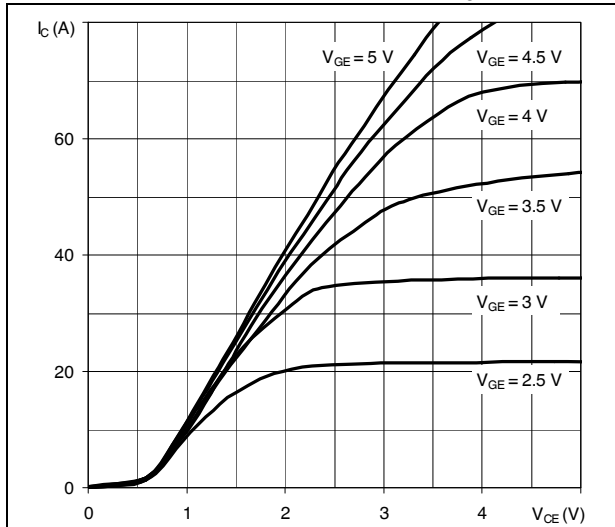

Figure 7. Transfer characteristics

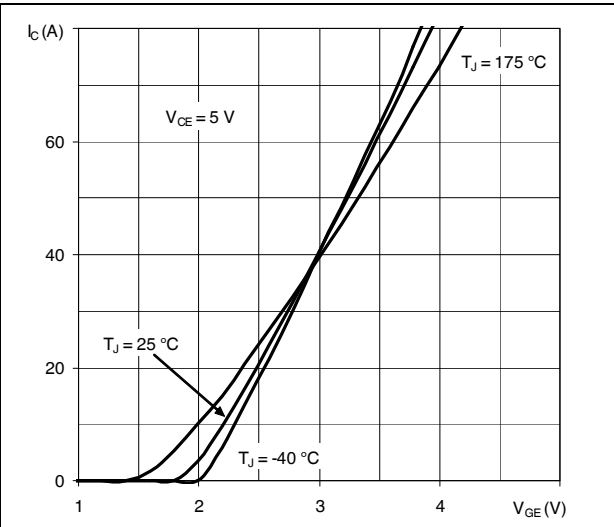

Figure 8. Collector cut-off current vs temperature

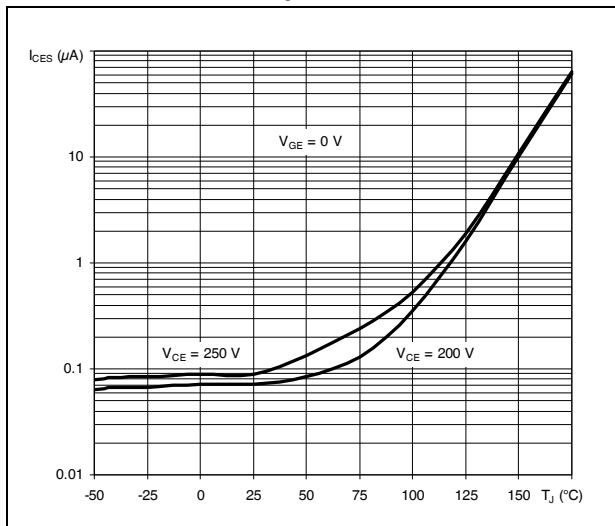

Figure 9. Normalized collector emitter voltage vs temperature

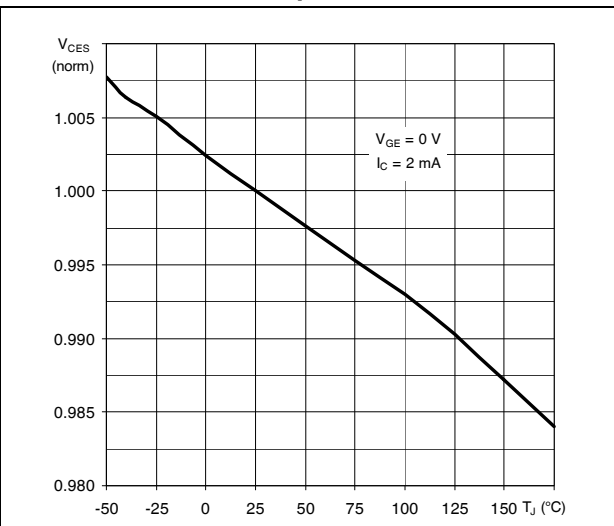

Figure 10. Normalized gate threshold voltage vs temperature

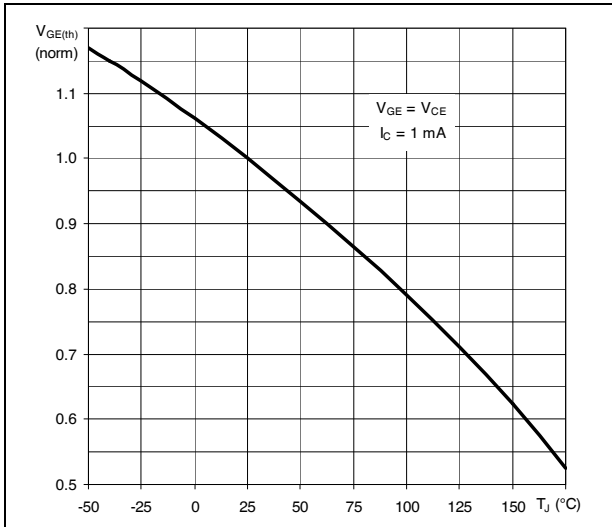

Figure 11. Gate charge

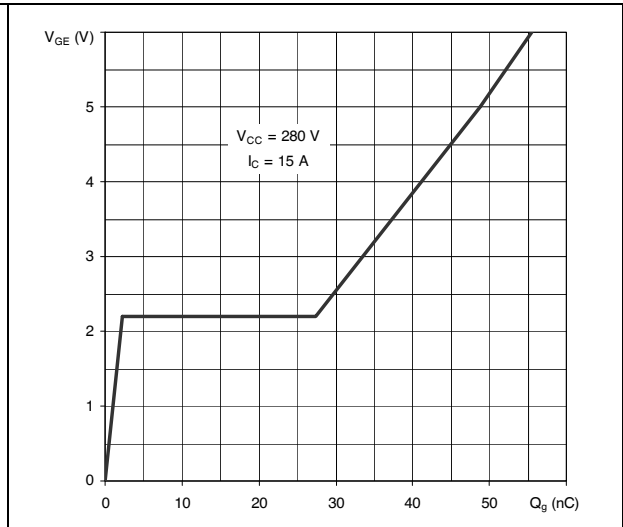
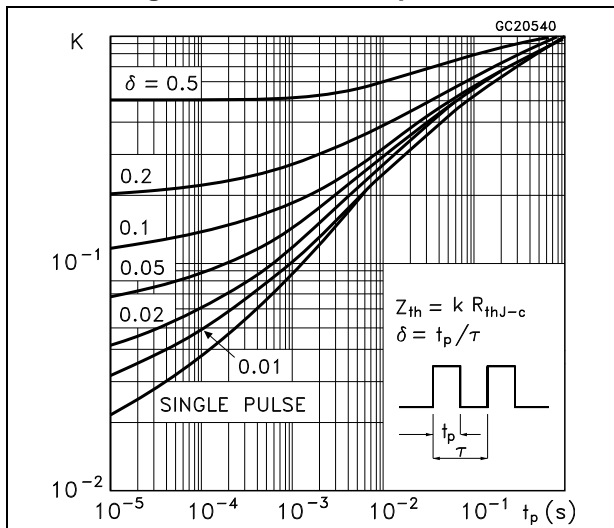

Figure 12. Thermal impedance



4 Package mechanical data

In order to meet environmental requirements, ST offers these devices in different grades of ECOPACK® packages, depending on their level of environmental compliance. ECOPACK® specifications, grade definitions and product status are available at: www.st.com. ECOPACK is an ST trademark.

Table 8. D²PAK (TO-263) mechanical data

Dim.	mm		
	Min.	Typ.	Max.
A	4.40		4.60
A1	0.03		0.23
b	0.70		0.93
b2	1.14		1.70
c	0.45		0.60
c2	1.23		1.36
D	8.95		9.35
D1	7.50		
E	10		10.40
E1	8.50		
e		2.54	
e1	4.88		5.28
H	15		15.85
J1	2.49		2.69
L	2.29		2.79
L1	1.27		1.40
L2	1.30		1.75
R		0.4	
V2	0°		8°

Figure 16. D²PAK (TO-263) drawing

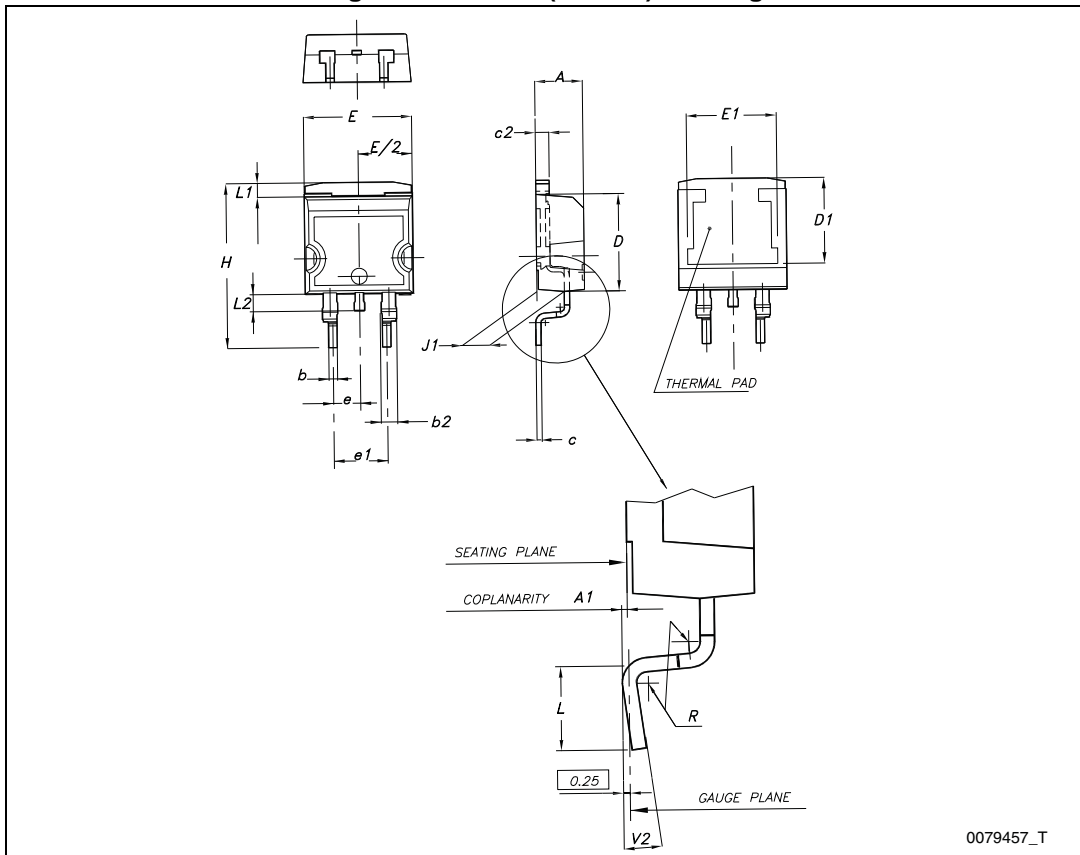
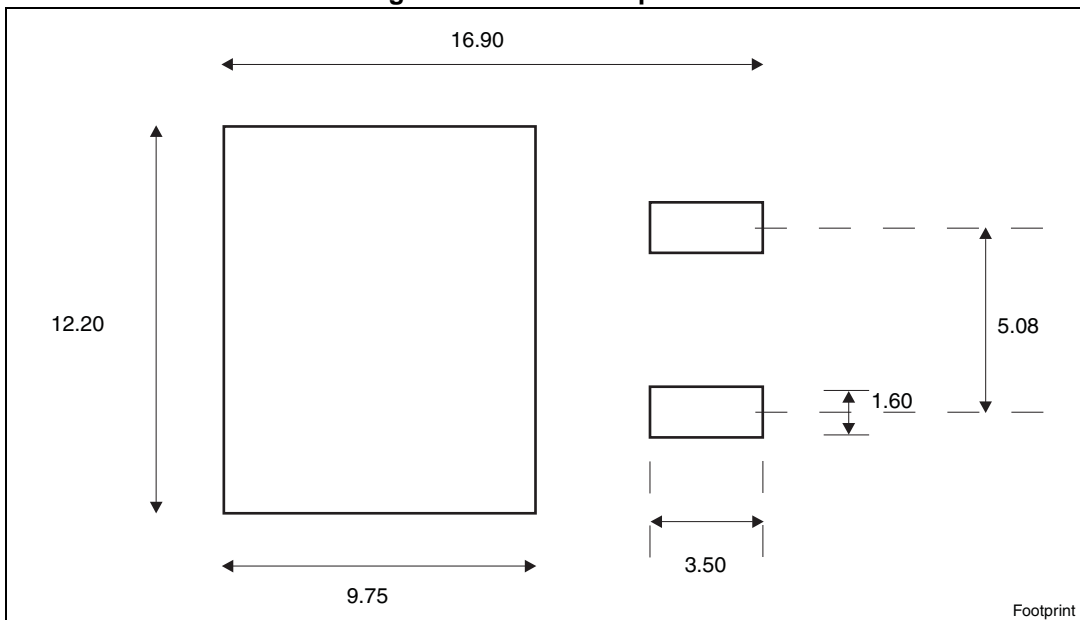

Figure 17. D²PAK footprint^(a)



a. All dimension are in millimeters

Table 9. I²PAK (TO-262) mechanical data

DIM.	mm.		
	min.	typ	max.
A	4.40		4.60
A1	2.40		2.72
b	0.61		0.88
b1	1.14		1.70
c	0.49		0.70
c2	1.23		1.32
D	8.95		9.35
e	2.40		2.70
e1	4.95		5.15
E	10		10.40
L	13		14
L1	3.50		3.93
L2	1.27		1.40

Figure 18. I²PAK (TO-262) drawing

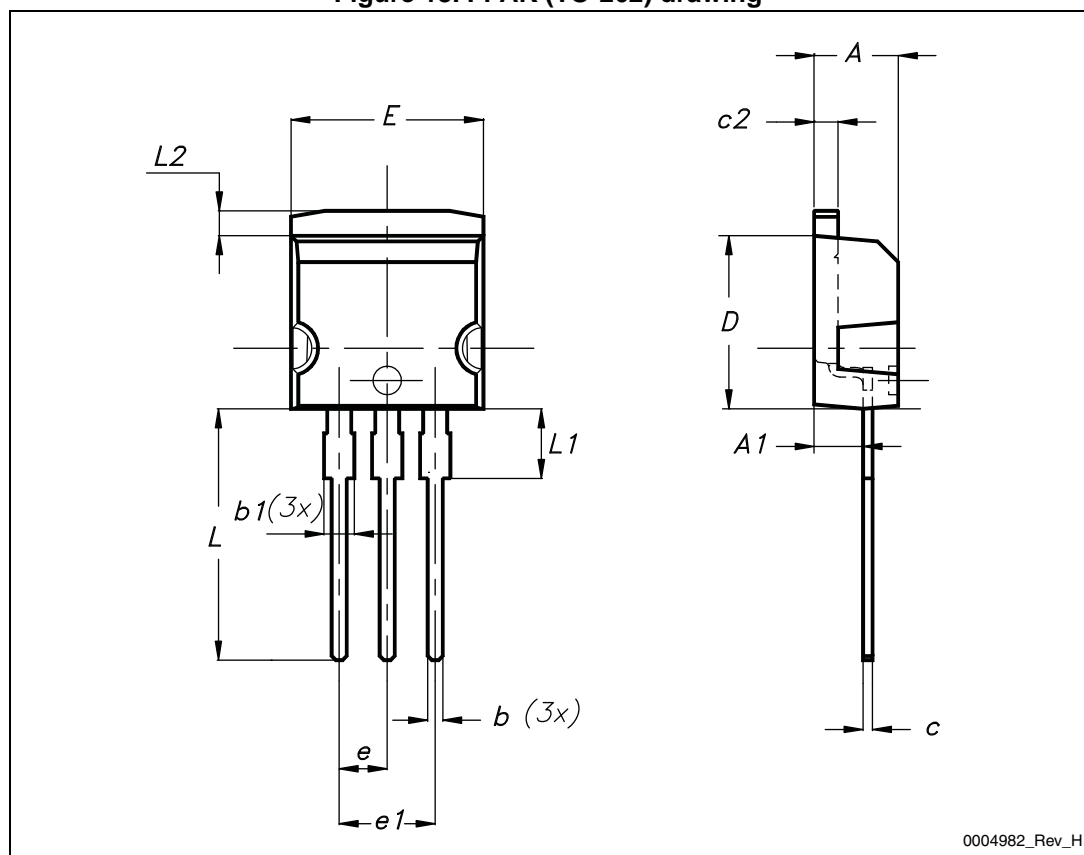
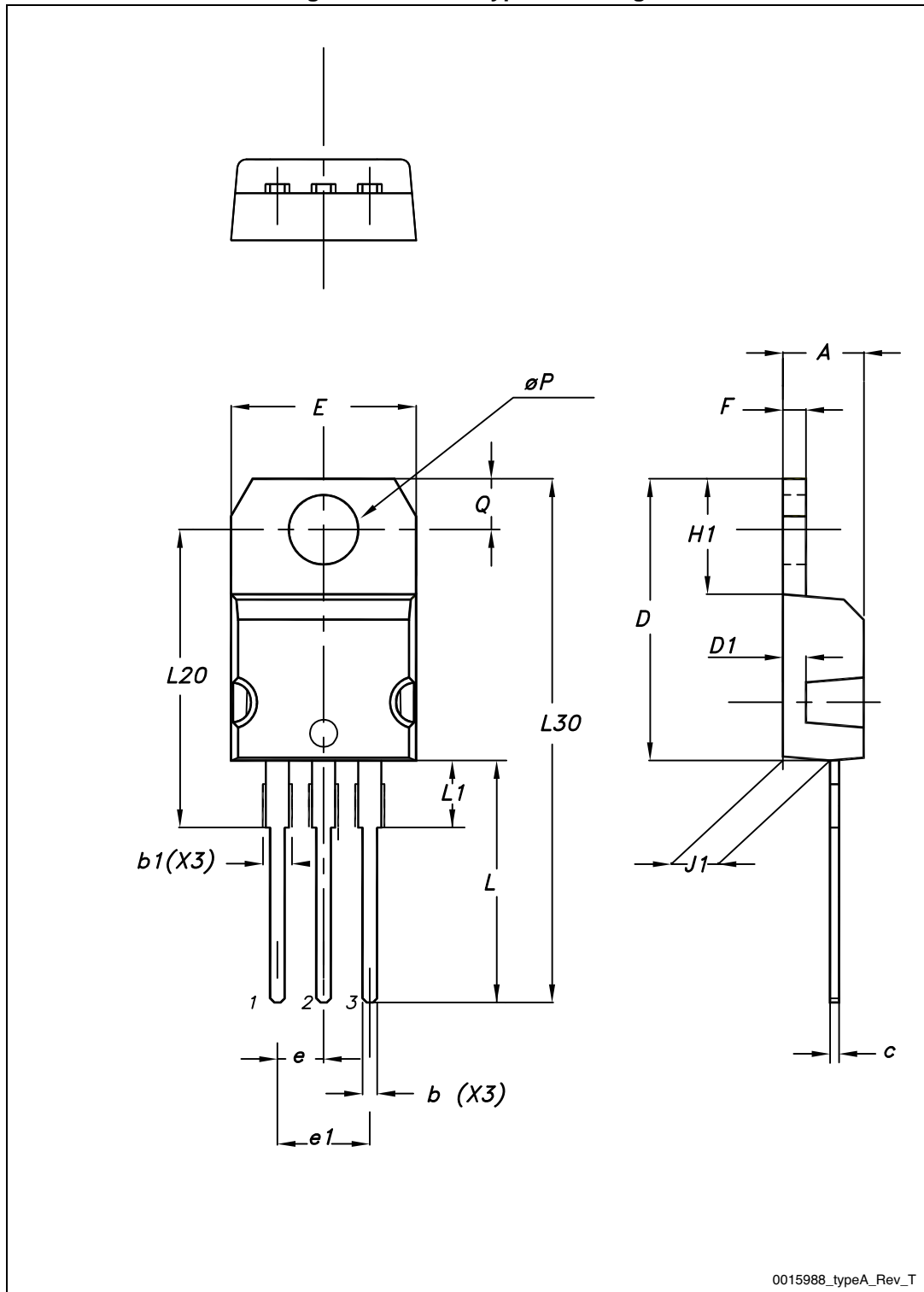

Table 10. TO-220 type A mechanical data

Dim.	mm		
	Min.	Typ.	Max.
A	4.40		4.60
b	0.61		0.88
b1	1.14		1.70
c	0.48		0.70
D	15.25		15.75
D1		1.27	
E	10		10.40
e	2.40		2.70
e1	4.95		5.15
F	1.23		1.32
H1	6.20		6.60
J1	2.40		2.72
L	13		14
L1	3.50		3.93
L20		16.40	
L30		28.90	
∅P	3.75		3.85
Q	2.65		2.95

Figure 19. TO-220 type A drawing



5 Packaging mechanical data

Table 11. D²PAK (TO-263) tape and reel mechanical data

Tape			Reel		
Dim.	mm		Dim.	mm	
	Min.	Max.		Min.	Max.
A0	10.5	10.7	A		330
B0	15.7	15.9	B	1.5	
D	1.5	1.6	C	12.8	13.2
D1	1.59	1.61	D	20.2	
E	1.65	1.85	G	24.4	26.4
F	11.4	11.6	N	100	
K0	4.8	5.0	T		30.4
P0	3.9	4.1			
P1	11.9	12.1		Base qty	1000
P2	1.9	2.1		Bulk qty	1000
R	50				
T	0.25	0.35			
W	23.7	24.3			

Figure 20. Tape for D²PAK (TO-263)

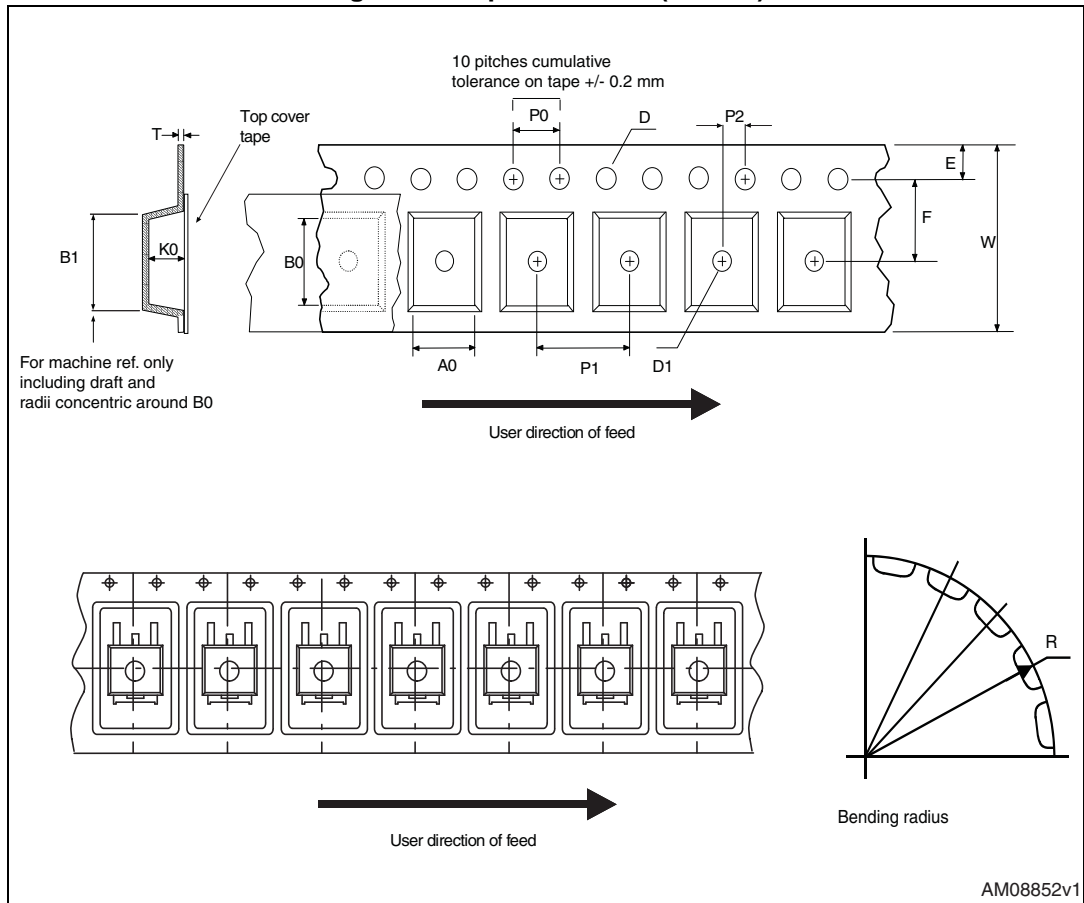
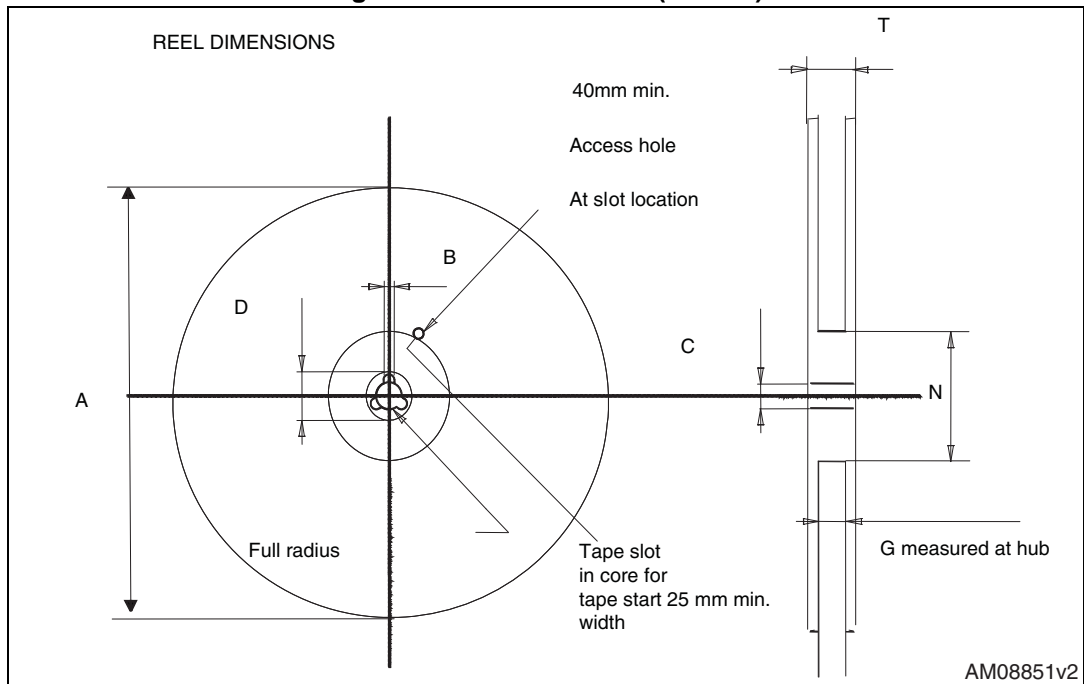

Figure 21. Reel for D²PAK (TO-263)



6 Revision history

Table 12. Document revision history

Date	Revision	Changes
29-Mar-2006	1	Initial release.
03-Jun-2009	2	Document status promoted from preliminary data to datasheet.
05-Nov-2009	3	Inserted Chapter 2.1: Electrical characteristics (curves)
16-Feb-2010	4	Added new package, mechanical data: TO-220
03-Jun-2010	5	<ul style="list-style-type: none">– Added Figure 12: Thermal impedance– Modified Figure 4, Figure 5, Figure 6 and Figure 7– D²PAK mechanical data has been updated
28-May-2013	6	<ul style="list-style-type: none">– Updated title in cover page, Chapter 5: Packaging mechanical data and Chapter 5: Packaging mechanical data.

Please Read Carefully:

Information in this document is provided solely in connection with ST products. STMicroelectronics NV and its subsidiaries ("ST") reserve the right to make changes, corrections, modifications or improvements, to this document, and the products and services described herein at any time, without notice.

All ST products are sold pursuant to ST's terms and conditions of sale.

Purchasers are solely responsible for the choice, selection and use of the ST products and services described herein, and ST assumes no liability whatsoever relating to the choice, selection or use of the ST products and services described herein.

No license, express or implied, by estoppel or otherwise, to any intellectual property rights is granted under this document. If any part of this document refers to any third party products or services it shall not be deemed a license grant by ST for the use of such third party products or services, or any intellectual property contained therein or considered as a warranty covering the use in any manner whatsoever of such third party products or services or any intellectual property contained therein.

UNLESS OTHERWISE SET FORTH IN ST'S TERMS AND CONDITIONS OF SALE ST DISCLAIMS ANY EXPRESS OR IMPLIED WARRANTY WITH RESPECT TO THE USE AND/OR SALE OF ST PRODUCTS INCLUDING WITHOUT LIMITATION IMPLIED WARRANTIES OF MERCHANTABILITY, FITNESS FOR A PARTICULAR PURPOSE (AND THEIR EQUIVALENTS UNDER THE LAWS OF ANY JURISDICTION), OR INFRINGEMENT OF ANY PATENT, COPYRIGHT OR OTHER INTELLECTUAL PROPERTY RIGHT.

ST PRODUCTS ARE NOT AUTHORIZED FOR USE IN WEAPONS. NOR ARE ST PRODUCTS DESIGNED OR AUTHORIZED FOR USE IN: (A) SAFETY CRITICAL APPLICATIONS SUCH AS LIFE SUPPORTING, ACTIVE IMPLANTED DEVICES OR SYSTEMS WITH PRODUCT FUNCTIONAL SAFETY REQUIREMENTS; (B) AERONAUTIC APPLICATIONS; (C) AUTOMOTIVE APPLICATIONS OR ENVIRONMENTS, AND/OR (D) AEROSPACE APPLICATIONS OR ENVIRONMENTS. WHERE ST PRODUCTS ARE NOT DESIGNED FOR SUCH USE, THE PURCHASER SHALL USE PRODUCTS AT PURCHASER'S SOLE RISK, EVEN IF ST HAS BEEN INFORMED IN WRITING OF SUCH USAGE, UNLESS A PRODUCT IS EXPRESSLY DESIGNATED BY ST AS BEING INTENDED FOR "AUTOMOTIVE, AUTOMOTIVE SAFETY OR MEDICAL" INDUSTRY DOMAINS ACCORDING TO ST PRODUCT DESIGN SPECIFICATIONS. PRODUCTS FORMALLY ESCC, QML OR JAN QUALIFIED ARE DEEMED SUITABLE FOR USE IN AEROSPACE BY THE CORRESPONDING GOVERNMENTAL AGENCY.

Resale of ST products with provisions different from the statements and/or technical features set forth in this document shall immediately void any warranty granted by ST for the ST product or service described herein and shall not create or extend in any manner whatsoever, any liability of ST.

ST and the ST logo are trademarks or registered trademarks of ST in various countries.

Information in this document supersedes and replaces all information previously supplied.

The ST logo is a registered trademark of STMicroelectronics. All other names are the property of their respective owners.

© 2013 STMicroelectronics - All rights reserved



STMicroelectronics group of companies

Australia - Belgium - Brazil - Canada - China - Czech Republic - Finland - France - Germany - Hong Kong - India - Israel - Italy - Japan - Malaysia - Malta - Morocco - Philippines - Singapore - Spain - Sweden - Switzerland - United Kingdom - United States of America

www.st.com

Looking for pricing, stock, or lifecycle information?

Click below to explore more details on WIN SOURCE:

-  [View STGB35N35LZT4 on WIN SOURCE](#)
-  [STMicroelectronics Information](#)

Optimize Your Supply Chain with WIN SOURCE Solutions

-  Global Sourcing Solution
-  Obsolete Management
-  Cost Control Management
-  Shortage Management
-  Alternative Solution
-  Excess Inventory Management