



**THE DATASHEET OF
MC14067BCPG**



MC14067B

Analog Multiplexers / Demultiplexers

The MC14067 multiplexer/demultiplexer is a digitally controlled analog switch featuring low ON resistance and very low leakage current. This device can be used in either digital or analog applications.

The MC14067 is a 16-channel multiplexer/demultiplexer with an inhibit and four binary control inputs A, B, C, and D. These control inputs select 1-of-16 channels by turning ON the appropriate analog switch (see MC14067 truth table.)

Features

- Low OFF Leakage Current
- Matched Channel Resistance
- Low Quiescent Power Consumption
- Low Crosstalk Between Channels
- Wide Operating Voltage Range: 3 to 18 V
- Low Noise
- Pin for Pin Replacement for CD4067B
- Pb-Free Packages are Available*

MAXIMUM RATINGS (Voltages Referenced to V_{SS})

Symbol	Parameter	Value	Unit
V_{DD}	DC Supply Voltage Range	- 0.5 to + 18.0	V
V_{in}, V_{out}	Input or Output Voltage Range (DC or Transient)	- 0.5 to $V_{DD} + 0.5$	V
I_{in}	Input Current (DC or Transient), per Control Pin	± 10	mA
I_{sw}	Switch Through Current	± 25	mA
P_D	Power Dissipation, per Package (Note 1)	500	mW
T_A	Ambient Temperature Range	- 55 to + 125	$^{\circ}C$
T_{stg}	Storage Temperature Range	- 65 to + 150	$^{\circ}C$
T_L	Lead Temperature (8-Second Soldering)	260	$^{\circ}C$

Maximum ratings are those values beyond which device damage can occur. Maximum ratings applied to the device are individual stress limit values (not normal operating conditions) and are not valid simultaneously. If these limits are exceeded, device functional operation is not implied, damage may occur and reliability may be affected.

1. Temperature Derating:

Plastic "P and D/DW" Packages: - 7.0 mW/ $^{\circ}C$ From 65 $^{\circ}C$ To 125 $^{\circ}C$

This device contains protection circuitry to guard against damage due to high static voltages or electric fields. However, precautions must be taken to avoid applications of any voltage higher than maximum rated voltages to this high-impedance circuit. For proper operation, V_{in} and V_{out} should be constrained to the range $V_{SS} \leq (V_{in} \text{ or } V_{out}) \leq V_{DD}$.

Unused inputs must always be tied to an appropriate logic voltage level (e.g., either V_{SS} or V_{DD}). Unused outputs must be left open.

*For additional information on our Pb-Free strategy and soldering details, please download the ON Semiconductor Soldering and Mounting Techniques Reference Manual, SOLDERRM/D.



ON Semiconductor®

<http://onsemi.com>

MARKING DIAGRAMS

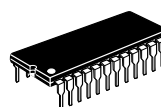

PDIP-24
P SUFFIX
CASE 709

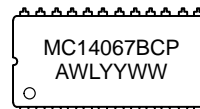

SOIC-24
DW SUFFIX
CASE 751E

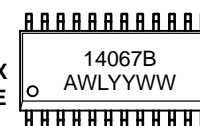

A = Assembly Location
WL = Wafer Lot
YY = Year
WW = Work Week

ORDERING INFORMATION

See detailed ordering and shipping information in the package dimensions section on page 4 of this data sheet.

MC14067B

TRUTH TABLE

Control Inputs					Selected Channel
A	B	C	D	Inh	
X	X	X	X	1	None
0	0	0	0	0	X0
1	0	0	0	0	X1
0	1	0	0	0	X2
1	1	0	0	0	X3
0	0	1	0	0	X4
1	0	1	0	0	X5
0	1	1	0	0	X6
1	1	1	0	0	X7
0	0	0	1	0	X8
1	0	0	1	0	X9
0	1	0	1	0	X10
1	1	0	1	0	X11
0	0	1	1	0	X12
1	0	1	1	0	X13
0	1	1	1	0	X14
1	1	1	1	0	X15

PIN ASSIGNMENT

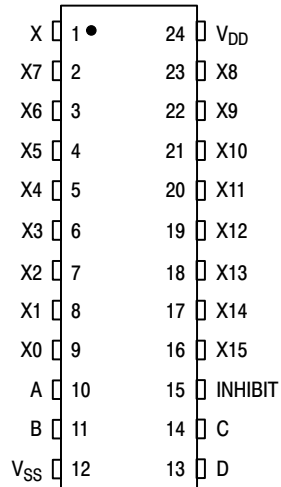

16-Channel Analog Multiplexer/Demultiplexer

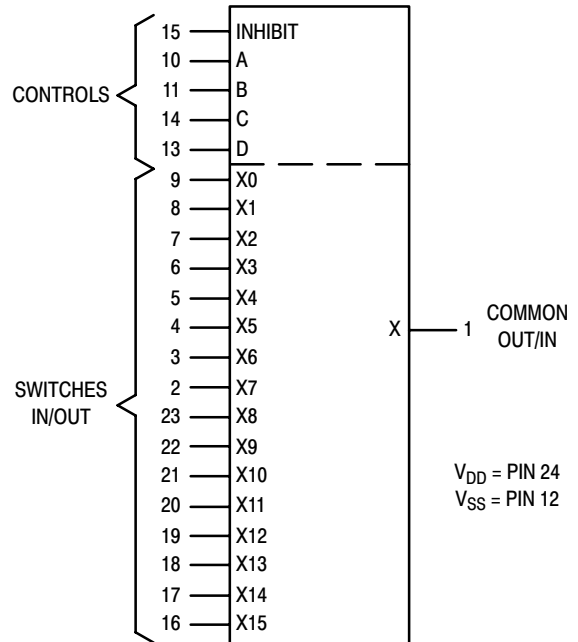

FUNCTIONAL DIAGRAM

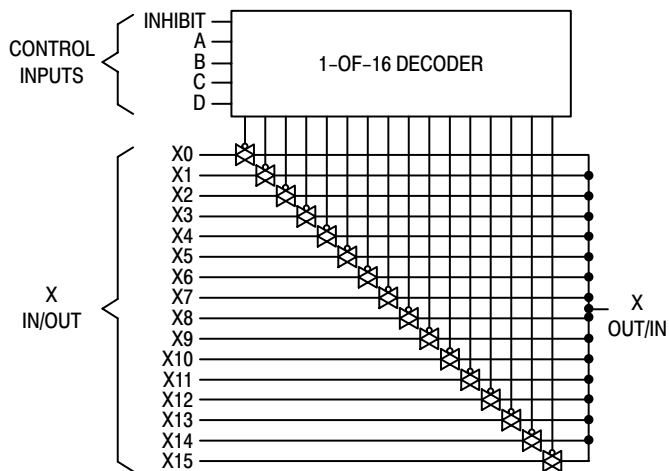

MC14067B

ELECTRICAL CHARACTERISTICS

Characteristic	Symbol	V _{DD}	Test Conditions	- 55°C		25°C			125°C		Unit
				Min	Max	Min	Typ (2)	Max	Min	Max	

SUPPLY REQUIREMENTS (Voltages Referenced to V_{SS})

Power Supply Voltage Range	V _{DD}	–		3.0	18	3.0	–	18	3.0	18	V
Quiescent Current Per Package	I _{DD}	5.0	Control Inputs: V _{in} = V _{SS} or V _{DD} , Switch I/O: V _{SS} ≤ V _{I/O} ≤ V _{DD} , and ΔV _{switch} ≤ 500 mV (3)	–	5.0	–	0.005	5.0	–	150	μA
		10		–	10	–	0.010	10	–	300	
		15		–	20	–	0.015	20	–	600	
Total Supply Current (Dynamic Plus Quiescent, Per Package)	I _{D(AV)}	5.0 10 15	T _A = 25°C only (The channel component, (V _{in} – V _{out})/R _{on} , is not included.)	Typical (0.07 μA/kHz) f + I _{DD} (0.20 μA/kHz) f + I _{DD} (0.36 μA/kHz) f + I _{DD}						μA	

CONTROL INPUTS — INHIBIT, A, B, C, D (Voltages Referenced to V_{SS})

Low-Level Input Voltage	V _{IL}	5.0	R _{on} = per spec, I _{off} = per spec	–	1.5	–	2.25	1.5	–	1.5	V
		10		–	3.0	–	4.50	3.0	–	3.0	
		15		–	4.0	–	6.75	4.0	–	4.0	
High-Level Input Voltage	V _{IH}	5.0	R _{on} = per spec, I _{off} = per spec	3.5	–	3.5	2.75	–	3.5	–	V
		10		7.0	–	7.0	5.50	–	7.0	–	
		15		11	–	11	8.25	–	11	–	
Input Leakage Current	I _{in}	15	V _{in} = 0 or V _{DD}	–	±0.1	–	±0.00001	±0.1	–	1.0	μA
Input Capacitance	C _{in}	–		–	–	–	5.0	7.5	–	–	pF

SWITCHES IN/OUT AND COMMONS OUT/IN — X, Y (Voltages Referenced to V_{SS})

Recommended Peak-to-Peak Voltage Into or Out of the Switch	V _{I/O}	–	Channel On or Off	0	V _{DD}	0	–	V _{DD}	0	V _{DD}	V _{p-p}
Recommended Static or Dynamic Voltage Across the Switch (3) (Figure 1)	ΔV _{switch}	–	Channel On	0	600	0	–	600	0	300	mV
Output Offset Voltage	V _{OO}	–	V _{in} = 0 V, No Load	–	–	–	10	–	–	–	μV
ON Resistance	R _{on}	5.0	ΔV _{switch} ≤ 500 mV (3), V _{in} = V _{IL} or V _{IH} (Control), and V _{in} 0 to V _{DD} (Switch)	–	800	–	250	1050	–	1300	Ω
		10		–	400	–	120	500	–	550	
		15		–	220	–	80	280	–	320	
ΔON Resistance Between Any Two Channels in the Same Package	ΔR _{on}	5.0		–	70	–	25	70	–	135	Ω
		10		–	50	–	10	50	–	95	
		15		–	45	–	10	45	–	65	
Off-Channel Leakage Current (Figure 2)	I _{off}	15	V _{in} = V _{IL} or V _{IH} (Control) Channel to Channel or Any One Channel	–	±100	–	±0.05	±100	–	±1000	nA
Capacitance, Switch I/O	C _{I/O}	–	Inhibit = V _{DD}	–	–	–	10	–	–	–	pF
Capacitance, Common O/I	C _{O/I}	–	Inhibit = V _{DD} (MC14067B) (MC14097B)	–	–	–	100	–	–	–	pF
				–	–	–	60	–	–	–	
Capacitance, Feedthrough (Channel Off)	C _{I/O}	–	Pins Not Adjacent	–	–	–	0.47	–	–	–	pF
		–		Pins Adjacent	–	–	–	–	–	–	

- Data labeled "Typ" is not to be used for design purposes, but is intended as an indication of the IC's potential performance.
- For voltage drops across the switch (ΔV_{switch}) > 600 mV (> 300 mV at high temperature), excessive V_{DD} current may be drawn; i.e. the current out of the switch may contain both V_{DD} and switch input components. The reliability of the device will be unaffected unless the Maximum Ratings are exceeded. (See first page of this data sheet.)

MC14067B

ELECTRICAL CHARACTERISTICS ($C_L = 50 \text{ pF}$, $T_A = 25^\circ\text{C}$)

Characteristic	Symbol	$V_{DD} - V_{SS}$ V_{dc}	Typ (4)	Max	Unit
Propagation Delay Times Channel Input-to-Channel Output ($R_L = 200 \text{ k}\Omega$) MC14067B	t_{PLH} , t_{PHL} (Figure 3)	5.0 10 15	35 15 12	90 40 30	ns
Control Input-to-Channel Output Channel Turn-On Time ($R_L = 10 \text{ k}\Omega$) MC14067B	t_{PZH} , t_{PZL} (Figure 4)	5.0 10 15	240 115 75	600 290 190	ns
Channel Turn-Off Time ($R_L = 300 \text{ k}\Omega$) MC14067B	t_{PHZ} , t_{PLZ} (Figure 4)	5.0 10 15	250 120 75	625 300 190	ns
Any Pair of Address Inputs to Output MC14067B	t_{PLH} , t_{PHL}	5.0 10 15	280 115 85	700 290 215	ns
Second Harmonic Distortion ($R_L = 10 \text{ k}\Omega$, $f = 1 \text{ kHz}$, $V_{in} = 5 V_{p-p}$)	–	10	0.3	–	%
ON Channel Bandwidth [$R_L = 1 \text{ k}\Omega$, $V_{in} = 1/2 (V_{DD} - V_{SS})$ p-p (sine-wave)] $20 \text{ Log}_{10} (V_{out}/V_{in}) = -3 \text{ dB}$ MC14067B	BW (Figure 5)	10	15	–	MHz
Off Channel Feedthrough Attenuation [$R_L = 1 \text{ k}\Omega$, $V_{in} = 1/2 (V_{DD} - V_{SS})$ p-p (sine-wave)] $f_{in} = 20 \text{ MHz}$ – MC14067B	– (Figure 5)	10	– 40	–	dB
Channel Separation [$R_L = 1 \text{ k}\Omega$, $V_{in} = 1/2 (V_{DD} - V_{SS})$ p-p (sine-wave)] $f_{in} = 20 \text{ MHz}$	– (Figure 6)	10	– 40	–	dB
Crosstalk, Control Inputs-to-Common O/I ($R_1 = 1 \text{ k}\Omega$, $R_L = 10 \text{ k}\Omega$, Control $t_r = t_f = 20 \text{ ns}$, Inhibit = V_{SS})	– (Figure 7)	10	30	–	mV

4. Data labelled "Typ" is not to be used for design purposes but is intended as an indication of the IC's potential performance.

ORDERING INFORMATION

Device	Package	Shipping†
MC14067BCP	PDIP-14	500 Units / Rail
MC14067BCPG	PDIP-14 (Pb-Free)	500 Units / Rail
MC14067BDW	SOIC-14	55 Units / Rail
MC14067BDWG	SOIC-14 (Pb-Free)	55 Units / Rail
MC14067BDWR2	SOIC-14	2500 Units / Tape & Reel
MC14067BDWR2G	SOIC-14 (Pb-Free)	2500 Units / Tape & Reel

†For information on tape and reel specifications, including part orientation and tape sizes, please refer to our Tape and Reel Packaging Specifications Brochure, BRD8011/D.

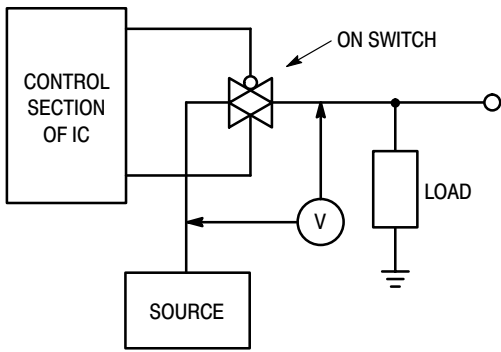

Figure 1. ΔV Across Switch

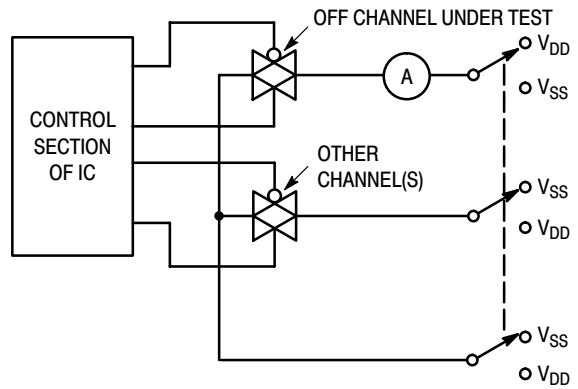

Figure 2. Off Channel Leakage

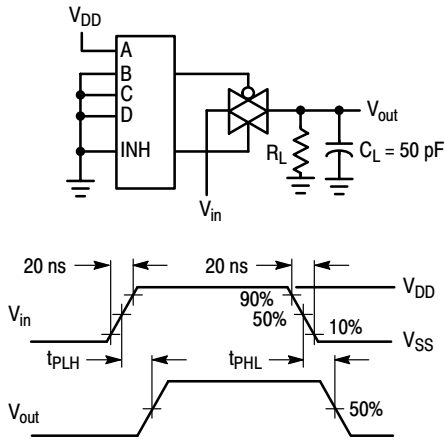

Figure 3. Propagation Delay Test Circuit and Waveforms V_{in} to V_{out}

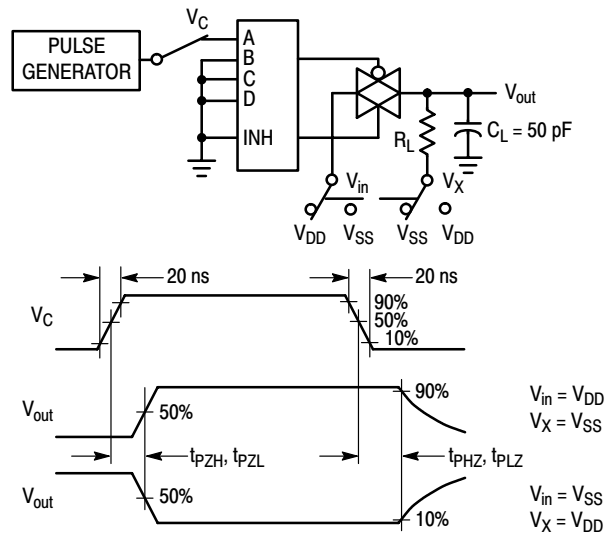

Figure 4. Turn-On and Delay Turn-Off Test Circuit and Waveforms

MC14067B

A, B, and C inputs used to turn ON or OFF the switch under test.

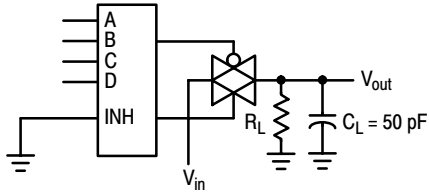

Figure 5. Bandwidth and Off-Channel Feedthrough Attenuation

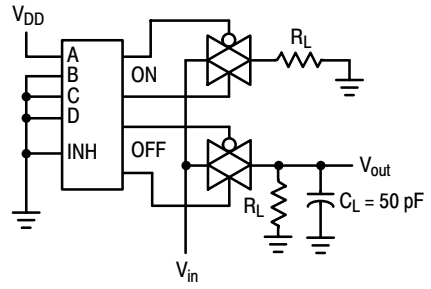

Figure 6. Channel Separation (Adjacent Channels Used for Setup)

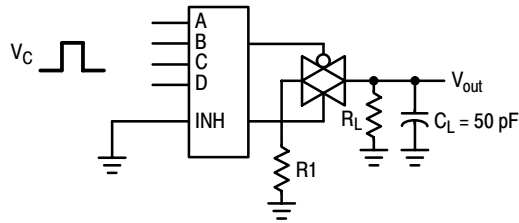

Figure 7. Crosstalk, Control to Common O/I

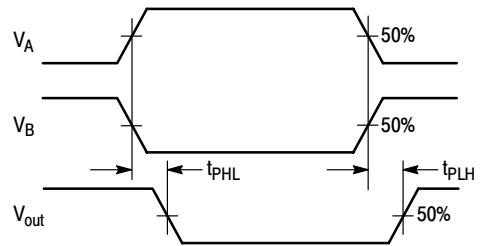
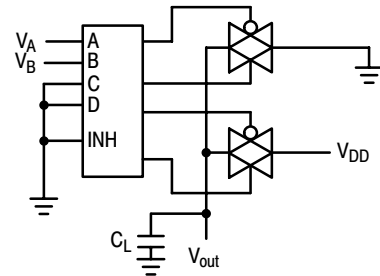

Figure 9. Propagation Delay, Any Pair of Address Inputs to Output

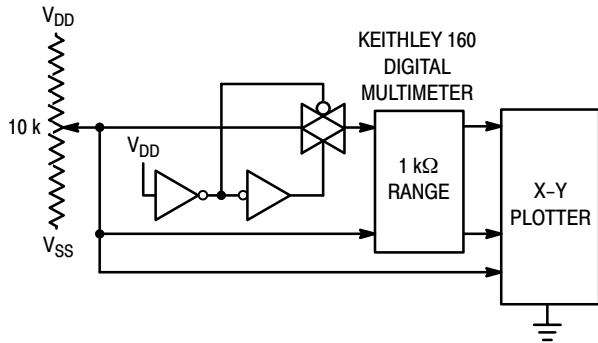

Figure 8. Channel Resistance (R_{ON}) Test Circuit

TYPICAL RESISTANCE CHARACTERISTICS

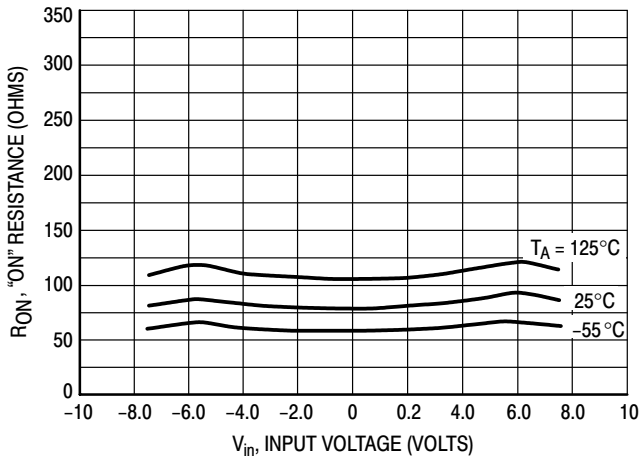

Figure 10. $V_{DD} = 7.5\text{ V}$, $V_{SS} = -7.5\text{ V}$

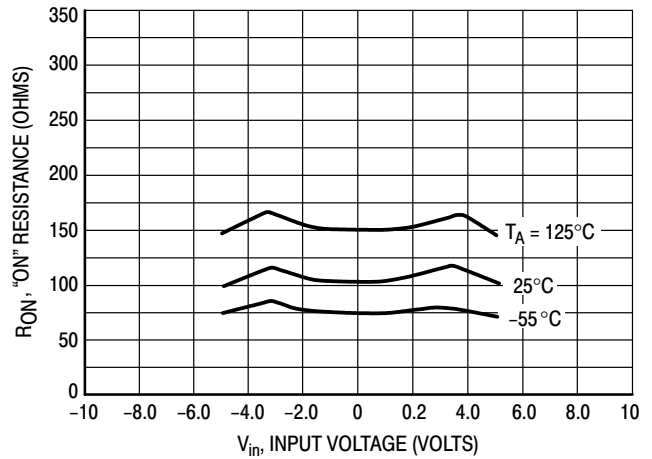

Figure 11. $V_{DD} = 5.0\text{ V}$, $V_{SS} = -5.0\text{ V}$

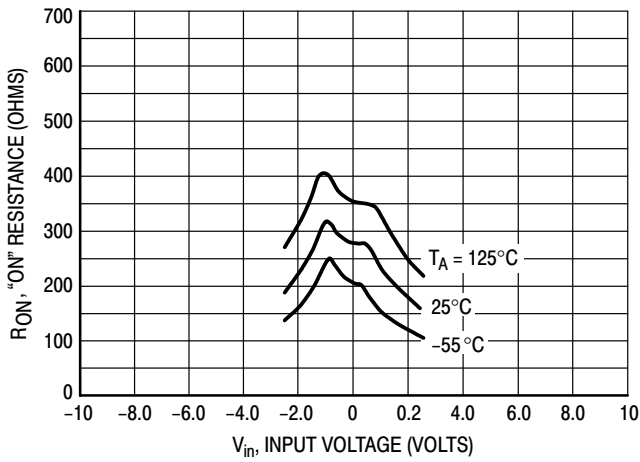

Figure 12. $V_{DD} = 2.5\text{ V}$, $V_{SS} = -2.5\text{ V}$

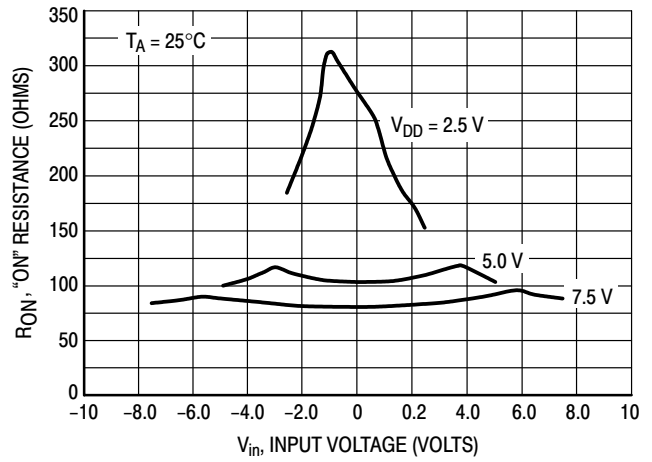

Figure 13. Comparison at 25°C, $V_{DD} = -V_{SS}$

APPLICATIONS INFORMATION

Figure A illustrates use of the Analog Multiplexer / Demultiplexer. The 0-to-5 V Digital Control signal is used to directly control a 5 V_{p-p} analog signal.

The digital control logic levels are determined by V_{DD} and V_{SS}. The V_{DD} voltage is the logic high voltage; the V_{SS} voltage is logic low. For the example, V_{DD} = + 5 V = logic high at the control inputs; V_{SS} = GND = 0 V = logic low.

The maximum analog signal level is determined by V_{DD} and V_{SS}. The analog voltage must swing neither higher than V_{DD} nor lower than V_{SS}. The example shows a 5 V_{p-p}

signal which allows no margin at either peak. If voltage transients above V_{DD} and/or below V_{SS} are anticipated on the analog channels, external diodes (D_x) are recommended as shown in Figure B. These diodes should be small signal types able to absorb the maximum anticipated current surges during clipping.

The absolute maximum potential difference between V_{DD} and V_{SS} is 18.0 volts. Most parameters are specified up to 15 V which is the recommended maximum difference between V_{DD} and V_{SS}.

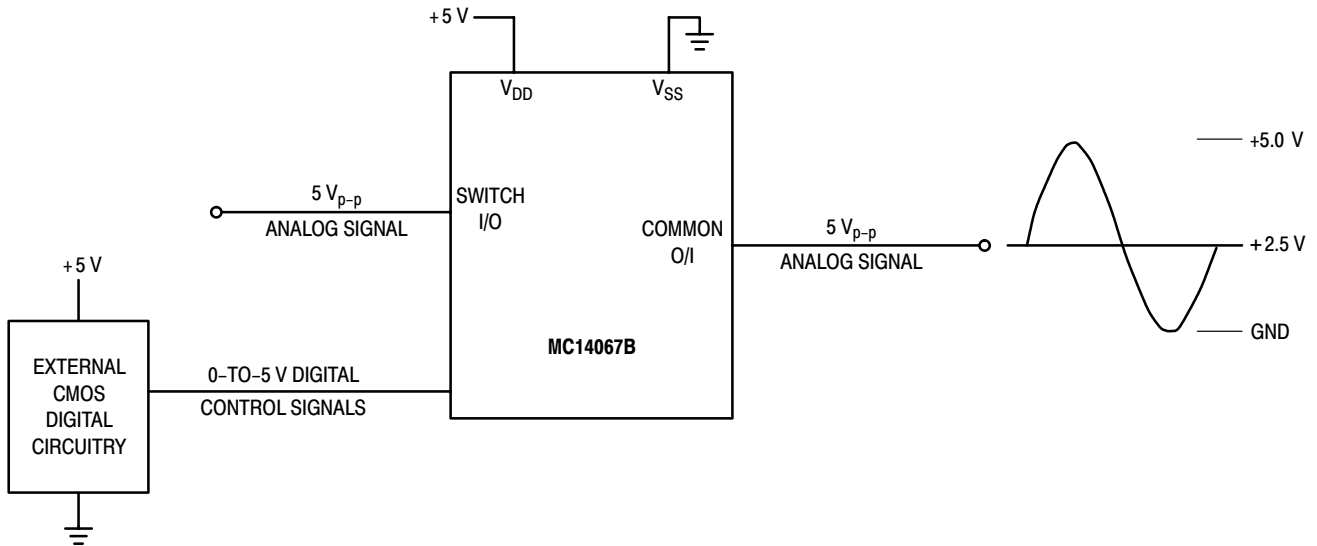

Figure A. Application Example

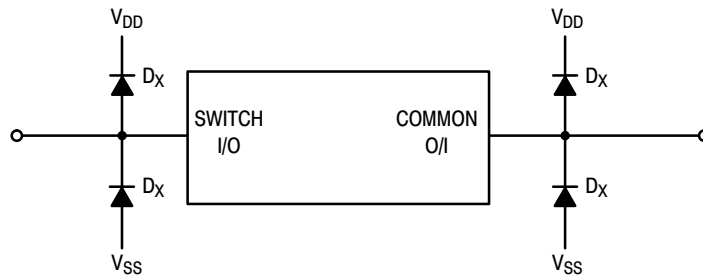
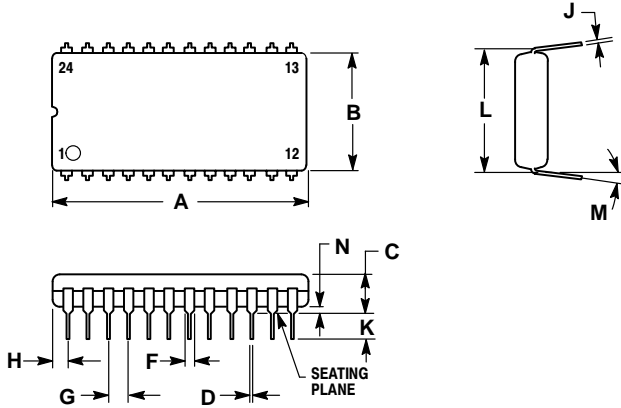

Figure B. External Germanium or Schottky Clipping Diodes

MC14067B

PACKAGE DIMENSIONS

PDIP-24
P SUFFIX
CASE 709-02
ISSUE C



NOTES:

1. POSITIONAL TOLERANCE OF LEADS (D), SHALL BE WITHIN 0.25 (0.010) AT MAXIMUM MATERIAL CONDITION, IN RELATION TO SEATING PLANE AND EACH OTHER.
2. DIMENSION L TO CENTER OF LEADS WHEN FORMED PARALLEL.
3. DIMENSION B DOES NOT INCLUDE MOLD FLASH.
4. CONTROLLING DIMENSION: INCH.

DIM	INCHES		MILLIMETERS	
	MIN	MAX	MIN	MAX
A	1.235	1.265	31.37	32.13
B	0.540	0.560	13.72	14.22
C	0.155	0.200	3.94	5.08
D	0.014	0.022	0.36	0.56
F	0.040	0.060	1.02	1.52
G	0.100 BSC		2.54 BSC	
H	0.065	0.080	1.65	2.03
J	0.008	0.015	0.20	0.38
K	0.115	0.135	2.92	3.43
L	0.600 BSC		15.24 BSC	
M	0°	15°	0°	15°
N	0.020	0.040	0.51	1.02

SOIC-24
DW SUFFIX
CASE 751E-04
ISSUE E

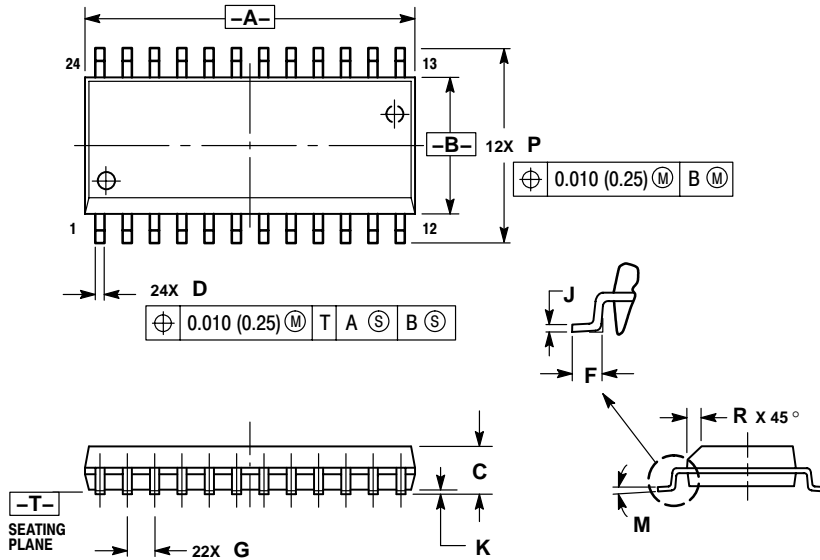

NOTES:

1. DIMENSIONING AND TOLERANCING PER ANSI Y14.5M, 1982.
2. CONTROLLING DIMENSION: MILLIMETER.
3. DIMENSIONS A AND B DO NOT INCLUDE MOLD PROTRUSION.
4. MAXIMUM MOLD PROTRUSION 0.15 (0.006) PER SIDE.
5. DIMENSION D DOES NOT INCLUDE DAMBAR PROTRUSION. ALLOWABLE DAMBAR PROTRUSION SHALL BE 0.13 (0.005) TOTAL IN EXCESS OF D DIMENSION AT MAXIMUM MATERIAL CONDITION.

DIM	MILLIMETERS		INCHES	
	MIN	MAX	MIN	MAX
A	15.25	15.54	0.601	0.612
B	7.40	7.60	0.292	0.299
C	2.35	2.65	0.093	0.104
D	0.35	0.49	0.014	0.019
F	0.41	0.90	0.016	0.035
G	1.27 BSC		0.050 BSC	
J	0.23	0.32	0.009	0.013
K	0.13	0.29	0.005	0.011
M	0°	8°	0°	8°
P	10.05	10.55	0.395	0.415
R	0.25	0.75	0.010	0.029

MC14067B

ON Semiconductor and  are registered trademarks of Semiconductor Components Industries, LLC (SCILLC). SCILLC reserves the right to make changes without further notice to any products herein. SCILLC makes no warranty, representation or guarantee regarding the suitability of its products for any particular purpose, nor does SCILLC assume any liability arising out of the application or use of any product or circuit, and specifically disclaims any and all liability, including without limitation special, consequential or incidental damages. "Typical" parameters which may be provided in SCILLC data sheets and/or specifications can and do vary in different applications and actual performance may vary over time. All operating parameters, including "Typicals" must be validated for each customer application by customer's technical experts. SCILLC does not convey any license under its patent rights nor the rights of others. SCILLC products are not designed, intended, or authorized for use as components in systems intended for surgical implant into the body, or other applications intended to support or sustain life, or for any other application in which the failure of the SCILLC product could create a situation where personal injury or death may occur. Should Buyer purchase or use SCILLC products for any such unintended or unauthorized application, Buyer shall indemnify and hold SCILLC and its officers, employees, subsidiaries, affiliates, and distributors harmless against all claims, costs, damages, and expenses, and reasonable attorney fees arising out of, directly or indirectly, any claim of personal injury or death associated with such unintended or unauthorized use, even if such claim alleges that SCILLC was negligent regarding the design or manufacture of the part. SCILLC is an Equal Opportunity/Affirmative Action Employer. This literature is subject to all applicable copyright laws and is not for resale in any manner.

PUBLICATION ORDERING INFORMATION

LITERATURE FULFILLMENT:

Literature Distribution Center for ON Semiconductor
P.O. Box 61312, Phoenix, Arizona 85082-1312 USA
Phone: 480-829-7710 or 800-344-3860 Toll Free USA/Canada
Fax: 480-829-7709 or 800-344-3867 Toll Free USA/Canada
Email: orderlit@onsemi.com

N. American Technical Support: 800-282-9855 Toll Free
USA/Canada

Japan: ON Semiconductor, Japan Customer Focus Center
2-9-1 Kamimeguro, Meguro-ku, Tokyo, Japan 153-0051
Phone: 81-3-5773-3850

ON Semiconductor Website: <http://onsemi.com>

Order Literature: <http://www.onsemi.com/litorder>

For additional information, please contact your
local Sales Representative.

Looking for pricing, stock, or lifecycle information?

Click below to explore more details on WIN SOURCE:

 [View MC14067BCPG on WIN SOURCE](#)

 [ON Semiconductor](#) Information

Optimize Your Supply Chain with WIN SOURCE Solutions

-  Global Sourcing Solution
-  Obsolete Management
-  Cost Control Management
-  Shortage Management
-  Alternative Solution
-  Excess Inventory Management