



**THE DATASHEET OF
AD1941YSTZ-29**



TABLE OF CONTENTS

Specifications.....	3	AD1941 I ² C Port.....	15
Digital I/O	3	RAMs and Registers.....	19
Power	3	Control Port Addressing	19
Digital Timing.....	4	Parameter RAM Contents.....	19
PLL	5	Recommended Program/Parameter Loading Procedures....	20
Regulator.....	5	Target/Slew RAM	20
Temperature Range	5	Safeload Registers	23
Absolute Maximum Ratings.....	6	Data Capture Registers	23
ESD Caution.....	6	DSP Core Control Register	24
Digital Timing Diagrams.....	7	RAM Configuration Register	25
Pin Configuration and Function Descriptions.....	9	Control Port Read/Write Data Formats	25
Features	11	Serial Data Input/Output Ports	28
Pin Functions	12	Serial Output Control Registers	30
Signal Processing	14	Serial Input Control Register	30
Overview.....	14	Initialization	33
Numeric Formats.....	14	Power-Up Sequence	33
Programming.....	14	Setting Master Clock/PLL Mode.....	33
Control Port.....	15	Voltage Regulator	33
Overview.....	15	Outline Dimensions	35
AD1940 SPI Port	15	Ordering Guide	35

REVISION HISTORY

4/10—Rev. A to Rev. B

Changes to Voltage Regulator Section.....	34
Updated Outline Dimensions	35
Changes to Ordering Guide	35

4/05—Rev. 0 to Rev. A

Added AD1941	Universal
Changes to Specifications	3
Changes to Pin Function Descriptions.....	9
Changes to Features Section.....	11
Changes to Pin Functions Section.....	13
Addition of AD1940 SPI Port Section	15
Added Table 13 to Table 16	18

7/04—Revision 0: Initial Version

SPECIFICATIONS

Test conditions, unless otherwise noted.

Table 1.

Parameter	Conditions
Supply Voltage (VDD)	2.5 V
PLL Voltage (PLL_VDD)	2.5 V
Output Voltage (ODVDD)	5.0 V
INVDD Voltage	5.0 V
Ambient Temperature	25°C
Master Clock Input	3.072 MHz, $64 \times f_s$ mode
Load Capacitance	50 pF
Load Current	± 1 mA
Input Voltage, HI	2.4 V
Input Voltage, LO	0.8 V

DIGITAL I/O

VDD = 2.25 V to 2.75 V. Specifications measured across -40°C to 125°C (case).

Table 2.

Parameter	Comments	Min	Max	Unit
Input Voltage, HI (V_{IH})		2.1		V
Input Voltage, LO (V_{IL})			0.8	V
Input Leakage (I_{IH})			10	μA
Input Leakage (I_{IL})			10	μA
High Level Output Voltage (V_{OH})	ODVDD = 4.5 V, $I_{OH} = 1$ mA	3.9		V
High Level Output Voltage (V_{OH})	ODVDD = 3.0 V, $I_{OH} = 1$ mA	2.6		V
Low Level Output Voltage (V_{OL})	ODVDD = 4.5 V, $I_{OL} = 1$ mA ¹		0.4	V
Low Level Output Voltage (V_{OL})	ODVDD = 3.0 V, $I_{OL} = 1$ mA ¹		0.3	V
Input Capacitance			5	pF

¹ SDA is measured with a 3 mA sink current.

POWER

Table 3.

Parameter	Min	Typ	Max ¹	Unit
SUPPLIES				
Voltage	2.25	2.5	2.75	V
Digital Current		92	155 ²	mA
PLL Current		3.5	8	mA
Digital Current, Reset		4.5 ³	13 ³	mA
PLL Current, Reset		3	8.5	mA
DISSIPATION				
Operation, All Supplies		238.8		mW
Reset, All Supplies		10.8		mW

¹ Maximum specifications are measured across -40°C to 125°C (case) and across VDD = 2.25 V to 2.75 V.

² Measurement running a typical large program that writes to all 16 outputs with 0 dB digital sine waves applied to all eight inputs. The end user's program may differ.

³ The digital reset current is specified for the given test conditions. This current scales with the input MCLK rate, so higher input clocks draw more current while in reset.

AD1940/AD1941

DIGITAL TIMING

VDD = 2.25 to 2.75 V. Specifications measured across –40°C to 125°C.

Table 4. Digital Timing¹

Parameter	Mnemonic	Comments	Min	Max	Unit
MASTER CLOCK, SERIAL DATA PORTS, RESET					
MCLK Period	t _{MP}	512 f _s mode	36	244	ns
MCLK Period	t _{MP}	384 f _s mode	48	366	ns
MCLK Period	t _{MP}	256 f _s mode	73	488	ns
MCLK Period	t _{MP}	64 f _s mode	291	1953	ns
MCLK Period	t _{MP}	Bypass mode	12		ns
MCLK Duty Cycle	t _{MDC}	Bypass mode	40	60	%
BCLK_IN LO Pulse Width	t _{BIL}		4		ns
BCLK_IN HI Pulse Width	t _{BIH}		2		ns
LRCLK_IN Setup	t _{LIS}	To BCLK_IN rising	12		ns
LRCLK_IN Hold	t _{LIH}	From BCLK_IN rising	0		ns
SDATA_INx Setup	t _{SIS}	To BCLK_IN rising	3		ns
SDATA_INx Hold	t _{SIH}	From BCLK_IN rising	2		ns
LRCLK_OUTx Setup	t _{LOS}	Slave mode	2		ns
LRCLK_OUTx Hold	t _{LOH}	Slave mode	2		ns
BCLK_OUTx Falling to LRCLK_OUTx Timing Skew	t _{TS}			2	ns
SDATA_OUTx Delay	t _{SODS}	Slave mode, from BCLK_OUTx falling		17	ns
SDATA_OUTx Delay	t _{SODM}	Master mode, from BCLK_OUTx falling		17	ns
RESETB LO Pulse Width	t _{RLPW}		10		ns
SPI PORT (AD1940)					
CCLK Pulse Width LO	t _{CCPL}		1 × INTMCLK (14) ²		ns
CCLK Pulse Width HI	t _{CCPH}		1 × INTMCLK (14) ²		ns
CLATCH Setup	t _{CLS}	To CCLK rising	0		ns
CLATCH Hold	t _{CLH}	From CCLK rising	2 × INTMCLK + 4 (32) ²		ns
CLATCH Pulse Width HI	t _{CLPH}		2 × INTMCLK (28) ²		ns
CDATA Setup	t _{CDS}	To CCLK rising	0		ns
CDATA Hold	t _{CDH}	From CCLK rising	2 × INTMCLK + 2 (30) ²		ns
COU Delay	t _{COD}	From CCLK rising		4 × INTMCLK + 18 (74) ²	ns
I ² C PORT (AD1941)					
SCL Clock Frequency	f _{SCL}			400	kHz
SCL Low	t _{SCLL}		1.3		μs
SCL High	t _{SCLH}		0.6		μs
Setup Time (Start Condition)	t _{SCS}	Relevant for repeated start condition	0.6		μs
Hold Time (Start Condition)	t _{SCH}	First clock generated after this period	0.6		μs
Setup Time (Stop Condition)	t _{SSH}		0.6		μs
Data Setup Time	t _{DS}		100		ns
SDA and SCL Rise Time	t _{SR}			300	ns
SDA and SCL Fall Time	t _{SF}			300	ns
Bus-Free Time	t _{BFT}	Between stop and start	1.3		μs

¹ All timing specifications are given for the default (I²S) states of the serial input control port and the serial output control ports. See Table 37.

² These specifications are based on the internal master clock period in a specific application. In normal operation, the master clock runs at 1,536 × f_s, so the internal master clock at f_s = 48 kHz has a 14 ns period. The values in parentheses are the timing values for f_s = 48 kHz.

PLL

VDD = 2.25 to 2.75 V. Specifications measured across -40°C to 125°C.

Table 5.

Parameter	Min	Typ	Max	Unit
Lock Time		3	20	ms

REGULATOR

VDD = 2.25 to 2.75 V. Specifications measured across -40°C to 125°C.

Table 6.

Parameter	Min	Typ	Max	Unit
VSENSE Output Voltage	2.25	2.5	2.68	V

TEMPERATURE RANGE

Table 7.

Parameter	Min	Typ	Max	Unit
Functionality Guaranteed	-40		+105	°C Ambient
	-40		+125	°C Case

ABSOLUTE MAXIMUM RATINGS

Table 8.

Parameter	Min	Max	Unit
VDD to DGND	-0.3	+3.0	V
PLL_ VDD to PGND	-0.3	+3.0	V
OD VDD to DGND	-0.3	+6.0	V
INVDD to DGND	ODVDD	+6.0	V
Digital Inputs	DGND - 0.3	INVDD + 0.3	V
Maximum Junction Temperature		135	°C
Storage Temperature Range	-65	+150	°C
Soldering (10 sec)		300	°C

Stresses above those listed under Absolute Maximum Ratings may cause permanent damage to the device. This is a stress rating only and functional operation of the device at these or any other conditions above those indicated in the operational section of this specification is not implied. Exposure to absolute maximum rating conditions for extended periods may affect device reliability.

Table 9. Package Characteristics

Parameter	Min	Typ	Max	Unit
θ_{JA} Thermal Resistance (Junction-to-Ambient)		72		°C/W
θ_{JC} Thermal Resistance (Junction-to-Case)		19.5		°C/W

ESD CAUTION

ESD (electrostatic discharge) sensitive device. Electrostatic charges as high as 4000 V readily accumulate on the human body and test equipment and can discharge without detection. Although this product features proprietary ESD protection circuitry, permanent damage may occur on devices subjected to high energy electrostatic discharges. Therefore, proper ESD precautions are recommended to avoid performance degradation or loss of functionality.



DIGITAL TIMING DIAGRAMS

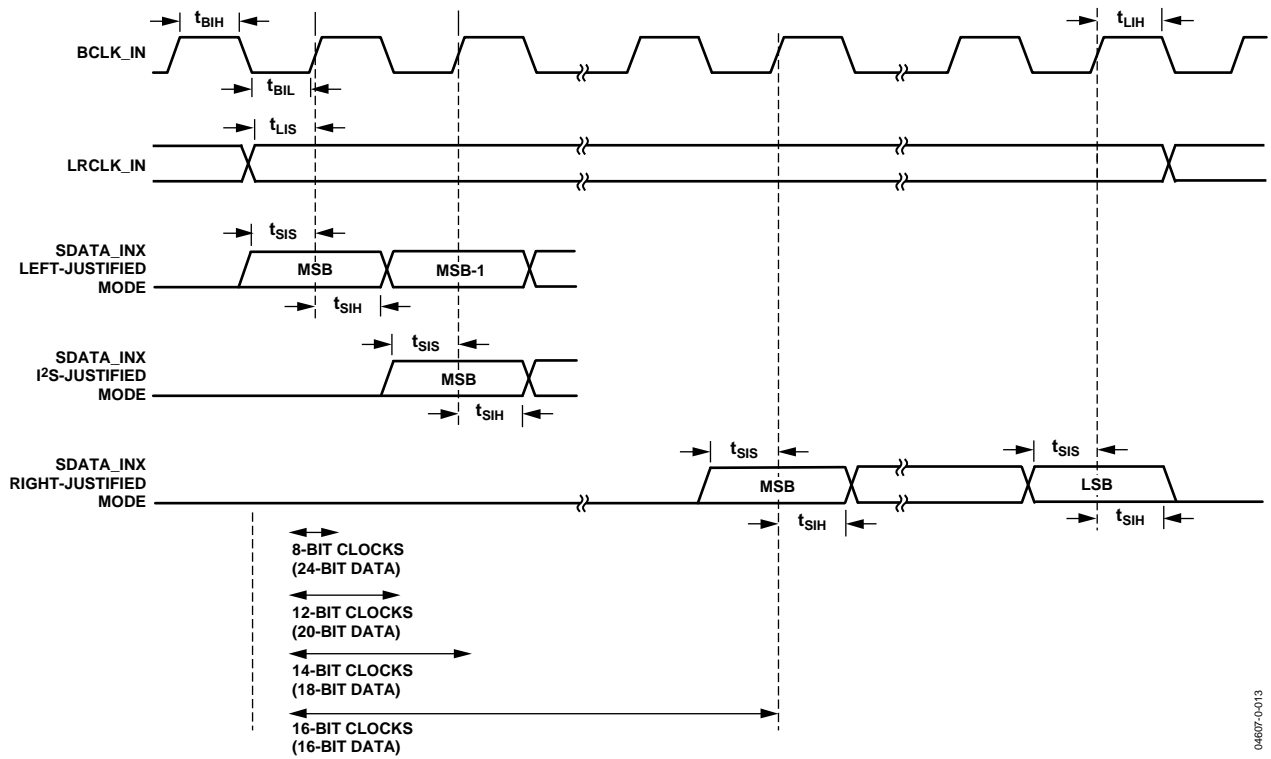

Figure 2. Serial Input Port Timing

04607-0-013

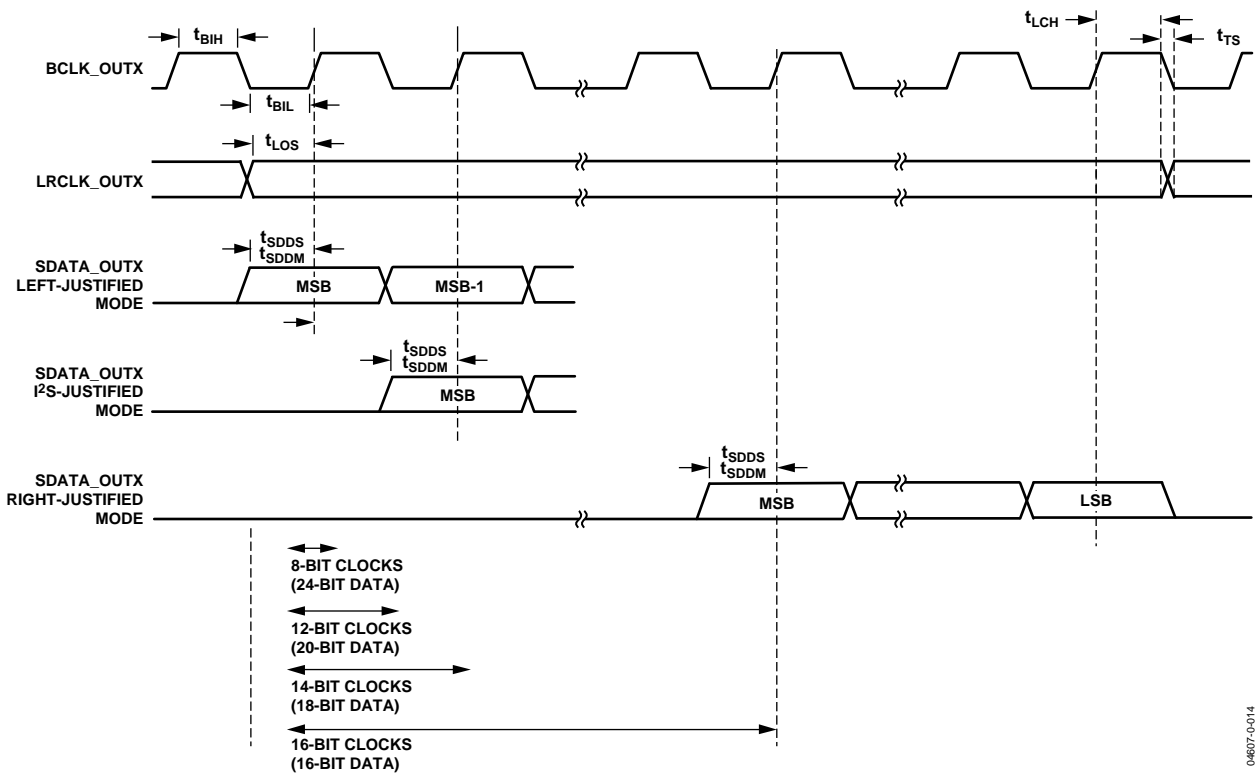

Figure 3. Serial Output Port Timing

04607-0-014

AD1940/AD1941

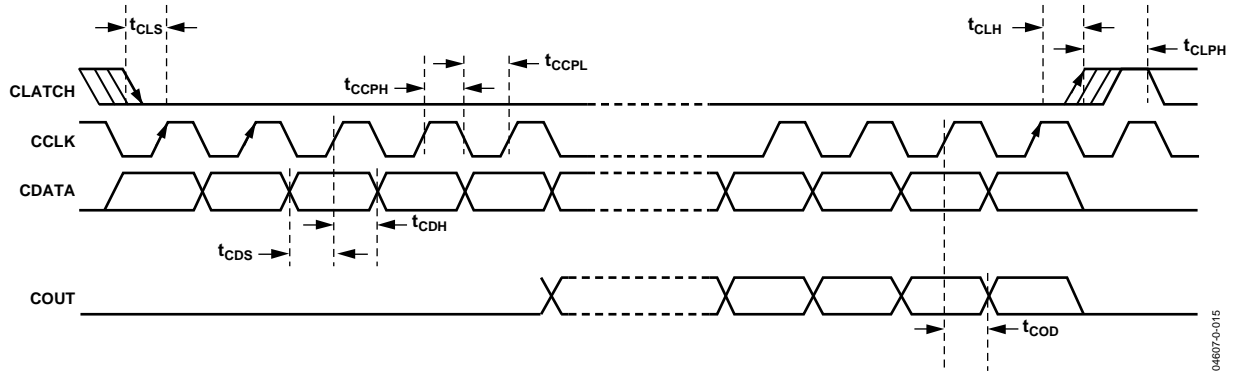

Figure 4. AD1940 SPI Port Timing

04607-015

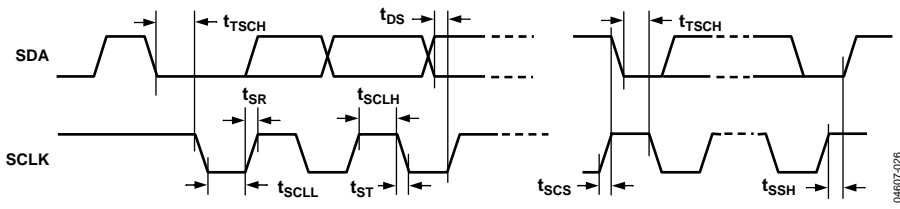

Figure 5. AD1941 I²C Port Timing

04607-026

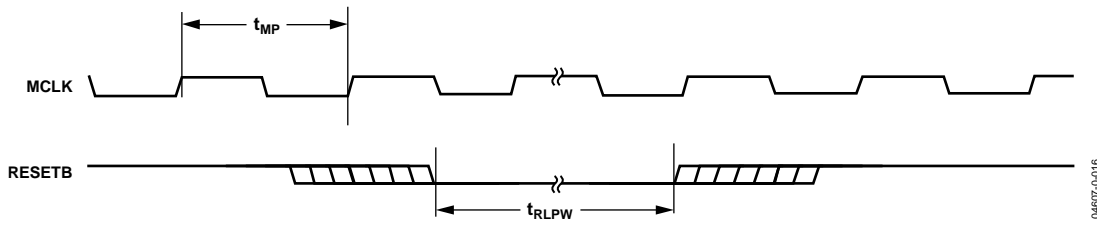

Figure 6. Master Clock and Reset Timing

04607-016

PIN CONFIGURATIONS AND FUNCTION DESCRIPTIONS

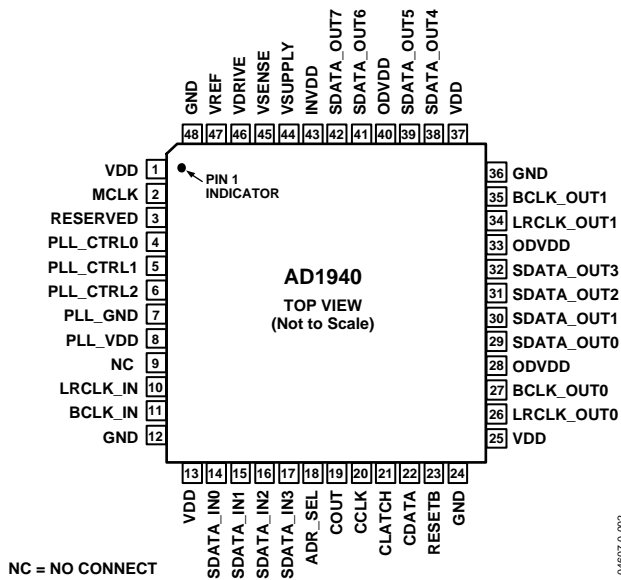

Figure 7. 48-Lead LQFP Pin Configuration, AD1940

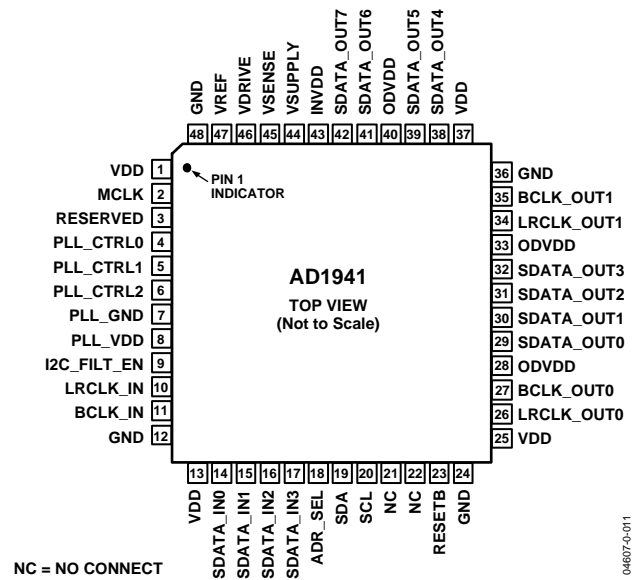

Figure 8. 48-Lead LQFP Pin Configuration, AD1941

Table 10. Pin Function Descriptions

Pin No.		I/O	Mnemonic	Description
AD1940	AD1941			
1, 25, 37	1, 25, 37		VDD	Core Power.
2	2	IN	MCLK	Master Clock Input.
3	3		RESERVED	This pin should be connected to ground.
4	4	IN	PLL_CTRL0	PLL Control 0.
5	5	IN	PLL_CTRL1	PLL Control 1.
6	6	IN	PLL_CTRL2	PLL Control 2.
7	7		PLL_GND	PLL Ground.
8	8		PLL_VDD	PLL Power.
9	21, 22		NC	No Connect.
	9	IN	I2C_FILTER_ENB	I ² C Filter Enable, Active Low.
10	10	IN	LRCLK_IN	Left/Right Clock for Serial or TDM Data Inputs.
11	11	IN	BCLK_IN	Bit Clock for Serial or TDM Data Inputs.
12, 24, 36, 48	12, 24, 36, 48		GND	Digital Ground.
13	13		VDD	Core Power.
14	14	IN	SDATA_IN0	Serial Data Input 0.
15	12	IN	SDATA_IN1	Serial Data Input 1.
16	16	IN	SDATA_IN2/TDM_IN1	Serial Data Input 2/TDM Input 1.
17	17	IN	SDATA_IN3/TDM_IN0	Serial Data Input 3/TDM Input 0.
18	18	IN	ADR_SEL	Control Port Address Select.
19		OUT	COUT	SPI Data Output.
20		IN	CCLK	Clock for SPI.
21		IN	CLATCH	SPI Data Latch.

AD1940/AD1941

Pin No.		I/O	Mnemonic	Description
AD1940	AD1941			
22		IN	CDATA	Data Input for SPI.
	19	IN/OUT	SDA	I ² C Serial Data I/O.
	20	IN	SCL	I ² C Clock.
23	23	IN	RESETB	Reset the AD1940/AD1941.
26	26	IN/OUT	LRCLK_OUT0	Left/Right Clock Output 0.
27	27	IN/OUT	BCLK_OUT0	Bit Clock Output 0.
28, 33, 40	28, 33, 40		ODVDD	Power Connection for Output Pins.
29	29	OUT	SDATA_OUT0/TDM_O0	Serial Data Output 0/TDM (16- or 8-Channel) Output 0.
30	30	OUT	SDATA_OUT1	Serial Data Output 1.
31	31	OUT	SDATA_OUT2	Serial Data Output 2.
32	32	OUT	SDATA_OUT3	Serial Data Output 3.
34	34	IN/OUT	LRCLK_OUT1	Left/Right Clock Output 1.
35	35	IN/OUT	BCLK_OUT1	Bit Clock Output 1.
38	38	OUT	SDATA_OUT4/TDM_O1	Serial Data Output 4./TDM (8-Channel) Output 1.
39	39	OUT	SDATA_OUT5	Serial Data Output 5.
41	41	OUT	SDATA_OUT6	Serial Data Output 6.
42	42	OUT	SDATA_OUT7/DCSOUT	Serial Data Output 7/Data Capture Output.
43	43		INVDD	Input Voltage Reference.
44	44	IN	VSUPPLY	Voltage Level Input to Regulator. Usually 3.3 V or 5 V.
45	45	IN	VSENSE	Digital Power Level. Should be tied to VDD.
46	46	OUT	VDRIVE	Drive for External PNP Transistor.
47	47	OUT	VREF	Reference Level for Voltage Regulator.

FEATURES

The core of the AD1940/AD1941 is a 28-bit DSP (56-bit, double precision) optimized for audio processing. The parts' program RAM can be loaded with a custom program after power-up. Signal processing parameters are stored in a 1024 location parameter RAM, which is initialized on power-up by an internal boot ROM. New values are written to the parameter RAM using the control port. The values stored in the parameter RAM control individual signal processing blocks, such as IIR equalization filters, dynamics processors, audio delays, and mixer levels. A safeload feature allows parameters to be transparently updated without causing clicks on the output signals.

The target/slew RAM contains 64 locations and can be used as channel volume controls or for other parameter updates. These RAM locations take a target value for a given parameter and ramp the current parameter value to the new value using a specified time constant and one of a selection of linear or logarithmic curves.

The AD1940/AD1941 contain eight independent data capture circuits that can be programmed to tap the signal flow of the processor at any point in the DSP algorithm flow. Six of these captured signals can be accessed by reading from the data capture registers through the control port. The remaining two data capture registers can be used to send any internal captured signal to a stereo digital output signal on Pin SDATA_OUT7 for driving external DACs or digital analyzers.

The AD1940/AD1941 have a sophisticated control port that supports complete read/write capability of all memory locations. Five control registers (Core, RAM configuration, Serial Output 0 to 7, Serial Output 8 to 15, and serial input) are provided to offer complete control of the chip's configuration and serial modes. Handshaking is included for ease of memory uploads/downloads. The AD1940 is SPI-controlled and the AD1941 is controlled by an I²C bus.

The AD1940/AD1941 have very flexible serial data input/output ports that allow glueless interconnection to a variety of ADCs, DACs, general-purpose DSPs, S/PDIF receivers and transmitters, and sample rate converters. The AD1940/AD1941 can be configured in I²S, left-justified, right-justified, or TDM serial port-compatible modes. It can support 16, 20, and 24 bits in all modes. The AD1940/AD1941 accepts serial audio data in MSB first and twos complement format.

A master clock phase-locked loop (PLL) allows the AD1940/AD1941 to be clocked from a variety of different clock speeds. The PLL can accept inputs of $64 \times f_s$, $256 \times f_s$, $384 \times f_s$, or $512 \times f_s$ to generate the core's internal master clock.

The AD1940/AD1941 operate from a single 2.5 V power supply. An on-board voltage regulator can be used to operate the chip with 3.3 V or 5 V supplies. They are fabricated on a single monolithic integrated circuit and are housed in 48-lead LQFP packages for operation over the -40°C to $+105^\circ\text{C}$ temperature range.

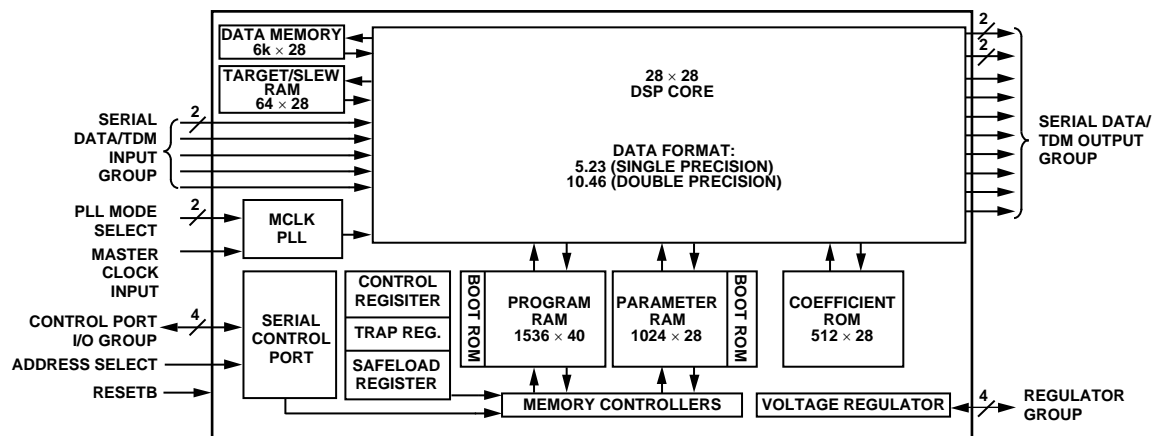

Figure 9. Block Diagram

AD1940/AD1941

PIN FUNCTIONS

Table 10 shows the AD1940/AD1941's pin numbers, names, and functions. Input pins have a logic threshold compatible with TTL input levels and may be used in systems with 3.3 V or 5 V logic.

SDATA_IN0

SDATA_IN1

SDATA_IN2/TDM_IN1

SDATA_IN3/TDM_IN0

Serial Data/TDM Inputs. The serial format is selected by writing to Bits 2:0 of the serial input port control register. SDATA_IN2 and SDATA_IN3 are dual-function pins that can be set to a variety of standard 2-channel formats or to TDM mode. Two of these four pins (SDATA_IN2 and SDATA_IN3) can be used as TDM inputs in either dual-wire 8-channel mode or single-wire 16-channel mode (TDM_O0 only). In dual-wire 8-channel mode, Channels 0 to 7 are input on SDATA_IN3 and Channels 8 to 15 on SDATA_IN2. In single-wire 16-channel mode, Channels 0 to 15 are input on SDATA_IN2. See the Serial Data Input/Output Ports section for further explanation.

LRCLK_IN

BCLK_IN

Left/Right and Bit Clocks for Timing the Input Data. These input clocks are associated with the SDATA_IN0 through SDATA_IN3 signals. The input port is always in a slave configuration. These pins also function as frame sync and bit clock for the input TDM stream.

SDATA_OUT0/TDM_O0

SDATA_OUT1

SDATA_OUT2

SDATA_OUT3

SDATA_OUT4/TDM_O1

SDATA_OUT5

SDATA_OUT6

SDATA_OUT7/DCSOUT

Serial Data/TDM/Data Capture Outputs. These pins are used for serial digital outputs. For non-TDM systems, these eight pins can output 16 channels of digital audio, using a variety of standard 2-channel formats. They are grouped into two groups of four pins (Pins 0 to 3 and Pins 4 to 7); each group can be independently set to any of the available serial modes, allowing the AD1940/AD1941 to simultaneously communicate with two external devices with different serial formats. Two of these eight pins (SDATA_OUT0 and SDATA_OUT4) can be used as TDM outputs in either dual-wire 8-channel mode or single-wire 16-channel mode (TDM_OUT0 only). In dual-wire 8-channel mode, Channels 0 to 7 are output on SDATA_OUT0 and Channels 8 to 15 on SDATA_OUT4. See the Serial Data Input/Output Ports section for further explanation. SDATA_OUT7 can also be used as a data capture output, as described in the Data Capture Registers section.

LRCLK_OUT0

BCLK_OUT0

Output Clocks. This clock pair is used for outputs SDATA_OUT0 through SDATA_OUT3. In slave mode, these clocks are inputs to the AD1940/AD1941. On power-up, these pins are set to slave mode to avoid conflicts with external master mode devices.

LRCLK_OUT1

BCLK_OUT1

Output Clocks. This clock pair is used for outputs SDATA_OUT4 through SDATA_OUT7. In slave mode, these clocks are inputs to the AD1940/AD1941. On power-up, these pins are set to slave mode to avoid conflicts with external master mode devices.

MCLK

Master Clock Input. The AD1940/AD1941 uses a PLL to generate the appropriate internal clock for the DSP core. An in-depth description of using the PLL is found in the Setting Master Clock/PLL Mode section.

PLL_CTRL0

PLL_CTRL1

PLL_CTRL2

PLL Mode Control Pins. The functionality of these pins is described in the Setting Master Clock/PLL Mode section.

CDATA (AD1940)

Serial Data Input for the SPI Control Port.

COU (AD1940)

Serial Data Output for the SPI Port. This is used for reading back registers and memory locations. It is three-stated when an SPI read is not active.

CCLK (AD1940)

SPI Bit Clock. This clock may either run continuously or be gated off between SPI transactions.

CLATCH (AD1940)

SPI Latch Signal. This must go low at the beginning of an SPI transaction and high at the end of a transaction. Each SPI transaction may take a different number of CCLKs to complete, depending on the address and read/write bit that are sent at the beginning of the SPI transaction.

SCL (AD1941)

I²C Clock. This pin is always an input because the AD1941 cannot act as a master on the I²C bus. The line connected to this pin should have a 2 k Ω pull-up resistor on it.

SDA (AD1941)

I²C Serial Data. The data line is bidirectional. The line connected to this pin should have a 2 k Ω pull-up resistor on it.

I²C_FILT_ENB (AD1941)

I²C Spike Filter Enable/Disable. This enables (active low) the I²C spike filter, which is used to prevent noise or glitches on the I²C bus from improperly affecting the AD1941.

ADR_SEL

Address Select. This pin selects the address for the AD1940/AD1941's communication with the control port. This allows two AD1940s to be used with a single CLATCH signal or two AD1941s to be used on the same I²C bus.

RESETB

Active-Low Reset Signal. After RESETB goes high, the AD1940/AD1941 goes through an initialization sequence where the program and parameter RAMs are initialized with the contents of the on-board boot ROMs. All registers are set to 0, and the data RAMs are also set to 0. The initialization is complete after 8,192 internal MCLK cycles (referenced to the rising edge of RESETB), which corresponds to 1,366 external MCLK cycles if the part is in $256 \times f_s$ mode. New values should not be written to the control port until the initialization is complete.

VREF

Voltage Reference for Regulator. This pin is driven by an internal 1.15 V reference voltage.

VDRIVE

Drive for External Transistor. The base of the voltage regulator's external PNP transistor is driven from this pin.

VSENSE

Digital Power Level. The voltage level on the VDD pins is sensed on VSENSE. VSENSE should be tied to VDD.

VSUPPLY

Main Supply Voltage Level. This pin is tied to the board's main voltage supply. This is usually 3.3 V or 5 V.

VDD (4)

Digital VDD for Core. 2.5 V nominal.

GND (4)

Digital Ground.

PLL_VDD

Supply for AD1940/AD1941 PLL. 2.5 V nominal.

PLL_GND

PLL Ground.

ODVDD (3)

VDD for All Digital Outputs. The high levels of the digital output signals are set on this pin. The voltage can range from 2.5 V to 5.0 V.

INVDD

Peak Input Voltage Level. The highest voltage level that the input pin sees should be connected to INVDD. This is to protect the chip inputs from voltage overstress. The voltage on this pin must always be at or above the level of ODVDD.

SIGNAL PROCESSING

OVERVIEW

The AD1940/AD1941 are designed to provide all signal processing functions commonly used in stereo or multichannel playback systems. The signal processing flow is set by using the ADI-supplied software, which allows graphical entry and real-time control of all signal processing functions.

Many of the signal processing functions are coded using full, 56-bit double-precision arithmetic. The input and output word lengths are 24 bits. Four extra headroom bits are used in the processor to allow internal gains up to 24 dB without clipping. Additional gains can be achieved by initially scaling down the input signal in the signal flow.

The signal processing blocks can be arranged in a custom program that can be loaded to the AD1940/AD1941's RAM. The available signal processing blocks are explained in the following sections.

NUMERIC FORMATS

It is common in DSP systems to use a standardized method of specifying numeric formats. Fractional number systems are specified by an A.B format, where A is the number of bits to the left of the decimal point and B is the number of bits to the right of the decimal point.

The AD1940/AD1941 use the same numeric format for both the coefficient values (stored in the parameter RAM) and the signal data values. The format is as follows:

Numerical Format: 5.23

Range: -16.0 to $(+16.0 - 1 \text{ LSB})$

Examples:

1000 0000 0000 0000 0000 0000 = -16.0
 1110 0000 0000 0000 0000 0000 = -4.0
 1111 1000 0000 0000 0000 0000 = -1.0
 1111 1110 0000 0000 0000 0000 = -0.25
 1111 1111 1111 1111 1111 1111 = (1 LSB below 0.0)
 0000 0000 0000 0000 0000 0000 = 0.0
 0000 0010 0000 0000 0000 0000 = 0.25
 0000 1000 0000 0000 0000 0000 = 1.0
 0010 0000 0000 0000 0000 0000 = 4.0
 0111 1111 1111 1111 1111 1111 = $(16.0 - 1 \text{ LSB})$.

The serial port accepts up to 24 bits on the input and is sign-extended to the full 28 bits of the core. This allows internal gains of up to 24 dB without encountering internal clipping.

A digital clipper circuit is used between the output of the DSP core and the serial output ports (see Figure 10). This clips the

top four bits of the signal to produce a 24-bit output with a range of 1.0 (minus 1 LSB) to -1.0 .

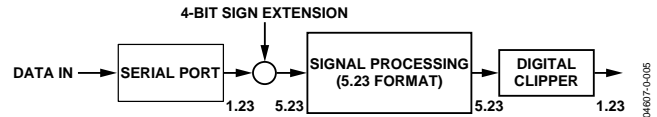

Figure 10. Numeric Precision and Clipping Structure

PROGRAMMING

On power-up, the AD1940/AD1941's default program passes the unprocessed input signals to the outputs (Figure 28) but the outputs are muted by default (see Power-Up Sequence section). There are 1,536 instruction cycles per audio sample, resulting in an internal clock rate of 73.728 MHz (for $f_s = 48 \text{ kHz}$). This DSP runs in a stream-oriented manner, meaning all 1,536 instructions are executed each sample period. The AD1940/AD1941 may also be set up to accept double- or quad-speed inputs by reducing the number of instructions/sample, which can be set in the core control register.

The part can be programmed easily using graphical tools provided by Analog Devices. No knowledge of writing DSP code is needed to program this part. The user simply can connect graphical blocks such as biquad filters, dynamics processors, mixers, and delays in a signal flow schematic, compile the design, and load the program and parameter files into the AD1940/AD1941's program RAM through the control port. Signal processing blocks available in the provided libraries include

- Single- and double-precision biquad filters
- Mono and multichannel dynamics processors
- Mixers and splitters
- Tone and noise generators
- First-order filters
- Fixed and variable gain
- RMS look-up tables
- Loudness
- Delay
- Stereo enhancement (Phat Stereo™)
- Dynamic bass boost
- Interpolators and deecimators

More blocks are always in development. Analog Devices also provides proprietary and third-party algorithms for applications such as matrix decoding, bass enhancement, and surround virtualizers. Contact an ADI sales representative for information about licensing these algorithms.

CONTROL PORT

OVERVIEW

The AD1940/AD1941 have many different control options that can be set through an SPI or I²C interface. The AD1940 uses a 4-wire SPI control port and the AD1941 uses a 2-wire I²C bus control port. Most signal processing parameters are controlled by writing new values to the parameter RAM using the control port. Other functions, such as mute and input/output mode control, are programmed by writing to the control registers.

The control port is capable of full read/write operation for all of the memories and registers. All addresses may be accessed in both a single-address mode or a burst mode. A control word consists of the chip address, the register/RAM subaddress, and the data to be written. The number of bytes per word depends on the type of data that is written.

The first byte of a control word (Byte 0) contains the 7-bit chip address plus the R/W bit. The next two bytes (Bytes 1 and 2) form the subaddress of the memory or register location within the AD1940/AD1941. This subaddress needs to be two bytes because the memories within the AD1940/AD1941 are directly addressable, and their sizes exceed the range of single-byte addressing. All subsequent bytes (Bytes 3, 4, etc.) contain the data, such as control port, program, or parameter data.

The exact formats for specific types of writes are shown in Table 26 to Table 35.

The AD1940/AD1941 have several mechanisms for updating signal processing parameters in real time without causing pops or clicks. In cases where large blocks of data need to be downloaded, the output of the DSP core can be halted (using Bit 9 of the core control register), new data loaded, and then restarted. This is typically done during the booting sequence at start-up or when loading a new program into RAM. In cases where only a few parameters need to be changed, they can be loaded without halting the program. To avoid unwanted side effects while loading parameters on the fly, the SigmaDSP provides the safeload registers. The safeload registers can be used to buffer a full set of parameters (for example, the five coefficients of a biquad) and then transfer these parameters into the active program within one audio frame. The safeload mode uses internal logic to prevent contention between the DSP core and the control port.

AD1940 SPI PORT

The SPI port uses a 4-wire interface, consisting of CLATCH, CCLK, CDATA, and COUT signals. The CLATCH signal goes low at the beginning of a transaction and high at the end of a transaction. The CCLK signal latches CDATA on a low-to-high transition. COUT data is shifted out of the AD1940/AD1941 on the falling edge of CCLK and should be clocked into the receiving device, such as a microcontroller, on CCLK's rising

edge. The CDATA signal carries the serial input data and the COUT signal is the serial output data. The COUT signal remains three-stated until a read operation is requested. This allows other SPI-compatible peripherals to share the same readback line. All SPI transactions follow the same basic format, shown in Table 11. A timing diagram is shown in Figure 4. All data written should be MSB first.

Table 11. Generic SPI Word Format

Byte 0	Byte 1	Byte 2	Byte 3	Byte 4, etc.
chip_adr [6:0], R/W	0000, subadr [11:8]	subadr [7:0]	Data	Data

Chip Address R/W

The first byte of an SPI transaction includes the 7-bit chip address and a R/W bit. The chip address is set by the ADR_SEL pin. This allows two AD1940s to share a CLATCH signal, yet operate independently. When ADR_SEL is low, the chip address is 0000000; when it is high, the address is 0000001. The LSB of this first byte determines whether the SPI transaction is a read (Logic Level 1) or a write (Logic Level 0).

Subaddress

The 12-bit subaddress word is decoded into a location in one of the memories or registers. This subaddress is the location of the appropriate RAM location or register.

Data Bytes

The number of data bytes varies according to the register or memory being accessed. In burst write mode, an initial subaddress is given followed by a continuous sequence of data for consecutive memory/register locations. The detailed data format diagram for continuous mode operation is given in the Control Port Read/Write Data Formats section.

A sample timing diagram for a single SPI write operation to the parameter RAM is shown in Figure 11. A sample timing diagram of a single SPI read operation is shown in Figure 12. The COUT pin goes from three-state to driven at the beginning of Byte 3. In this example, Bytes 0 to 2 contain the addresses and R/W bit, and subsequent bytes carry the data.

AD1941 I²C PORT

The AD1941 supports a 2-wire serial (I²C-compatible) micro-processor bus driving multiple peripherals. Two pins, serial data (SDA) and serial clock (SCL), carry information between the AD1941 and the system I²C master controller. The AD1941 is always a slave on the I²C bus, which means that it never initiates a data transfer. Each slave device is recognized by a unique address. The AD1941 has four possible slave addresses, two for writing operations and two for reading. These are unique addresses for the device and are illustrated in Table 12. The LSB

AD1940/AD1941

of the byte sets either a read or write operation; Logic Level 1 corresponds to a read operation and Logic Level 0 corresponds to a write operation. The seventh bit of the address is set by tying the ADR_SEL pin of the AD1941 to Logic Level 0 or Logic Level 1.

The AD1941 I²C port uses a spike filter that can be enabled or disabled by the I2C_FILT_ENB pin. Enabling this filter guarantees that all isolated spikes, both positive and negative, less than 50 ns wide are removed from the I²C signal. The filter is active when the I2C_FILT_ENB pin is low and is disabled when the pin is high. Typically, the largest spike that is filtered is 67 ns wide.

Table 12. AD1941 I²C Addresses

ADR_SEL	R/W	Slave Address
0	0	0x28
0	1	0x29
1	0	0x2A
1	1	0x2B

Addressing

Initially, all devices on the I²C bus are in an idle state, which is where the devices monitor the SDA and SCL lines for a start condition and the proper address. The I²C master initiates a data transfer by establishing a start condition, defined by a high-to-low transition on SDA while SCL remains high. This indicates that an address/data stream will follow. All devices on the bus respond to the start condition and read the next byte (7-bit address + R/W bit) MSB first. The device that recognizes the transmitted address responds by pulling the data line low during the ninth clock pulse. This ninth bit is known as an acknowledge bit. All other devices withdraw from the bus at this point and return to the idle condition. The R/W bit determines the direction of the data. A Logic 0 on the LSB of the first byte means the master writes information to the peripheral. A Logic 1 on the LSB of the first byte means the master reads information from the peripheral. A data transfer takes place until a stop condition is encountered. A stop condition occurs when SDA transitions from low to high while SCL is held high. Figure 13 shows the timing of an I²C write.

Burst mode addressing, where the subaddresses are automatically incremented at word boundaries, can be used for writing large amounts of data to contiguous memory locations. This increment happens automatically if a stop condition is not encountered after a single-word write. The registers and memories in the AD1941 range in width from one to five bytes, so the autoincrement feature knows the mapping between subaddresses and the word length of the destination register (or memory location). A data transfer is always terminated by a stop condition.

Stop and start conditions can be detected at any stage during the data transfer. If these conditions are asserted out of sequence with normal read and write operations, these cause an immediate jump to the idle condition. During a given SCL high period, the user should only issue one start condition, one stop condition, or a single stop condition followed by a single start condition. If an invalid subaddress is issued by the user, the AD1941 does not issue an acknowledge and returns to the idle condition. If the user exceeds the highest subaddress while in autoincrement mode, one of two actions are taken. In read mode, the AD1941 outputs the highest subaddress register contents until the master device issues a no-acknowledge, indicating the end of a read. A no-acknowledge condition is where the SDA line is not pulled low on the ninth clock pulse on SCL. If the highest subaddress location is reached while in write mode, the data for the invalid byte is not loaded into any subaddress register, a no-acknowledge is issued by the AD1941 and the part returns to the idle condition.

I²C Read and Write Operations

Table 13 shows the timing of a single-word write operation. Every ninth clock, the AD1941 issues an acknowledge by pulling SDA low.

Table 14 shows the timing of a burst mode write sequence. This figure shows an example where the target destination registers are two bytes. The AD1941 knows to increment its subaddress register every two bytes because the requested subaddress corresponds to a register or memory area with a 2-byte word length.

The timing of a single word read operation is shown in Table 15. Note that the first R/W bit is still a 0, indicating a write operation. This is because the subaddress still needs to be written in order to set up the internal address. After the AD1941 acknowledges the receipt of the subaddress, the master must issue a repeated start command followed by the chip address byte with the R/W set to 1 (read). This causes the AD1941's SDA to turn around and begin driving data back to the master. The master then responds every ninth pulse with an acknowledge pulse to the AD1941.

Table 16 shows the timing of a burst mode read sequence. This figure shows an example where the target read registers are two bytes. The AD1941 knows to increment its subaddress register every two bytes because the requested subaddress corresponds to a register or memory area with word lengths of two bytes. Other address ranges may have a variety of word lengths ranging from one to five bytes; the AD1941 always decodes the subaddress and sets the autoincrement circuit so that the address increments after the appropriate number of bytes.

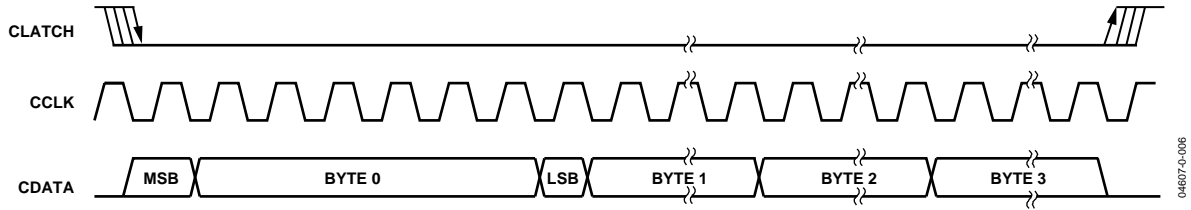

Figure 11. SPI Write Format (Single Write Mode)

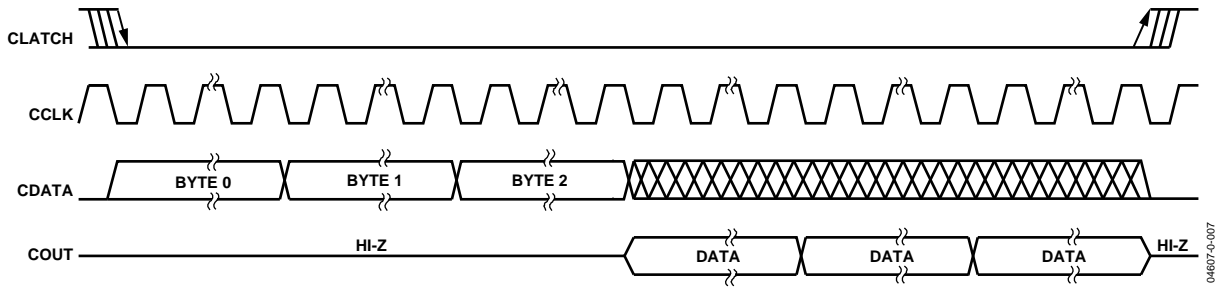

Figure 12. SPI Read Format (Single Read Mode)

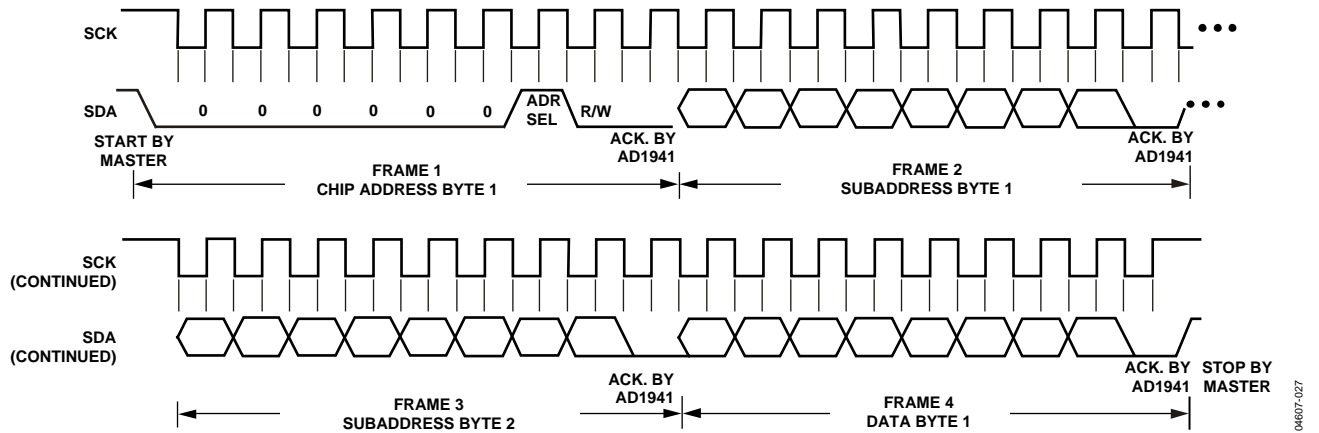

Figure 13. AD1941 I²C Write Format

AD1940/AD1941

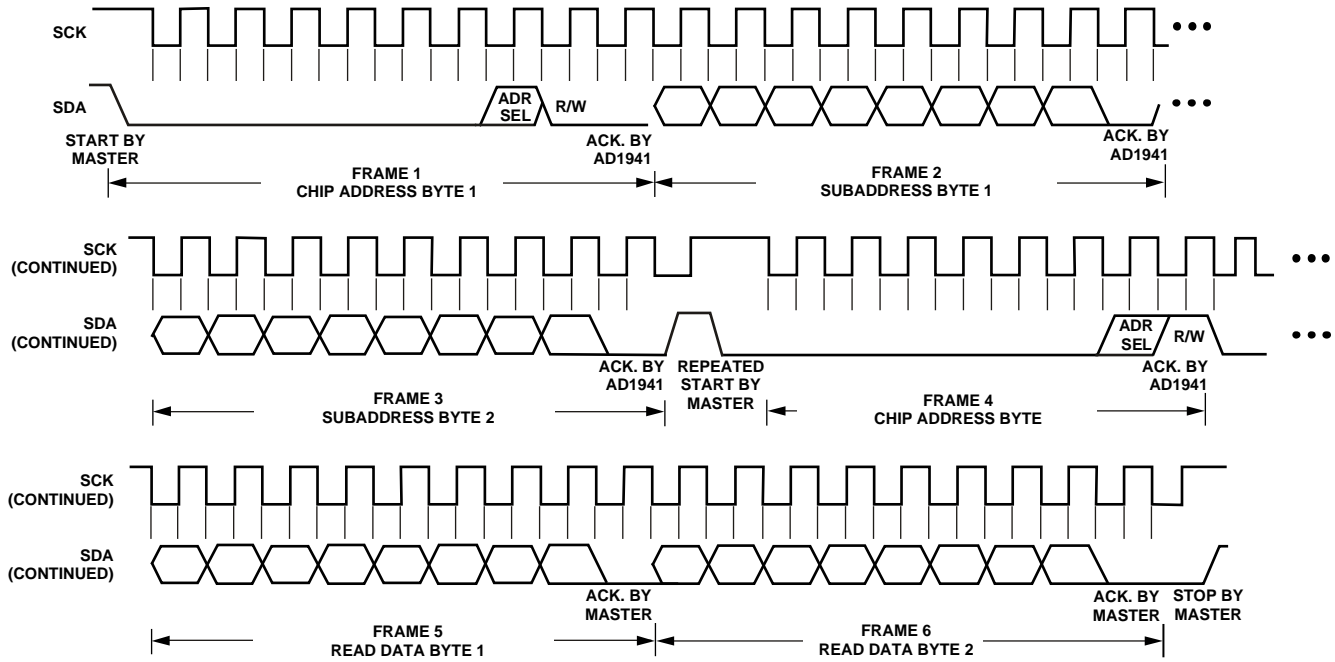

Figure 14. AD1941 I²C Read Format

Table 13. Single Word I²C Write

S	Chip Address, R/W = 0	AS	Subaddress High	AS	Subaddress Low	AS	Data Byte 1	AS	Data Byte 2	...	AS	Data Byte N	P
---	-----------------------	----	-----------------	----	----------------	----	-------------	----	-------------	-----	----	-------------	---

Table 14. Burst Mode I²C Write

S	Chip Address, R/W = 0	AS	Subaddress High	AS	Subaddress Low	AS	Data Word 1, Byte 1	AS	Data Word 1, Byte 2	AS	Data Word 2, Byte 1	AS	Data Word 2, Byte 2	AS	...	P
---	-----------------------	----	-----------------	----	----------------	----	---------------------	----	---------------------	----	---------------------	----	---------------------	----	-----	---

Table 15. Single Word I²C Read

S	Chip Address, R/W = 0	AS	Subaddress High	AS	Subaddress Low	AS	S	Chip Address, R/W = 1	AS	Data Byte 1	AM	Data Byte 2	...	AM	Data Byte N	P
---	-----------------------	----	-----------------	----	----------------	----	---	-----------------------	----	-------------	----	-------------	-----	----	-------------	---

Table 16. Burst Mode I²C Read

S	Chip Address, R/W = 0	AS	Subaddress High	AS	Subaddress Low	AS	S	Chip Address, R/W = 1	AS	Data Word 1, Byte 1	AM	Data Word 1, Byte 2	AM	...	P
---	-----------------------	----	-----------------	----	----------------	----	---	-----------------------	----	---------------------	----	---------------------	----	-----	---

S - Start Bit
P - Stop Bit
AM - Acknowledge by Master
AS - Acknowledge by Slave

RAMS AND REGISTERS

Table 17. Control Port Addresses

SPI/ I ² C Subaddress	Register Name	Read/Write Word Length
0–1023 (0x0000–0x03FF)	Parameter RAM	Write: 4 bytes, read: 4 bytes
1024–2559 (0x0400–0x09FF)	Program RAM	Write: 5 bytes, read: 5 bytes
2560–2623 (0x0A00–0x0A3F)	Target/Slew RAM	Write: 5 bytes, read: n/a
2624–2628 (0x0A40–0x0A44)	Parameter RAM Data Safeload Registers 0–4	Write: 5 bytes, read: n/a
2629–2633 (0x0A45–0x0A49)	Parameter RAM Indirect Address Safeload Registers 0–4	Write: 2 bytes, read: n/a
2634–2639 (0x0A4A–0x0A4F)	Data Capture Registers 0–5 (Control Port Readback)	Write: 2 bytes, read: 3 bytes
2640–2641 (0x0A50–0x0A51)	Data Capture Registers (Digital Output)	Write: 2 bytes, read: n/a
2642 (0x0A52)	DSP Core Control Register	Write: 2 bytes, read: 2 bytes
2643 (0x0A53)	RAM Configuration Register	Write: 1 byte, read: 1 byte
2644 (0x0A54)	Serial Output Control Register 1 (Channels 0–7)	Write: 2 bytes, read: 2 bytes
2645 (0x0A55)	Serial Output Control Register 2 (Channels 8–15)	Write: 2 bytes, read: 2 bytes
2646 (0x0A56)	Serial Input Control Register	Write: 1 byte, read: 1 byte

Table 18. RAM Read/Write Modes

Memory	Size	Subaddress Range	Read	Write	Burst Mode Available	Write Modes
Parameter RAM	1024 × 28	0–1023 (0x0000–0x03FF)	Yes	Yes	Yes	Direct write ¹ or safeload write
Program RAM	1536 × 40	1024–2559 (0x0400–0x09FF)	Yes	Yes	Yes	Direct write ¹
Target/Slew RAM	64 × 34	2560–2623 (0x0A00–0x0A3F)	No	Yes (via safeload)	Yes ²	Safeload write

¹ DSP core should be shut down first to avoid clicks/pops.

² The target/slew RAMs need to be written through the safeload registers. Safeload writes may be done in either single write mode or burst mode.

CONTROL PORT ADDRESSING

Table 17 shows the addressing of the AD1940/AD1941's RAM and register spaces. The address space encompasses a set of registers and three RAMs: one each for holding signal processing parameters, holding the program instructions, and ramping parameter values. The program and parameter RAMs are initialized on power-up from on-board boot ROMs.

Table 18 shows the sizes and available writing modes of the parameter, program, and target/slew RAMs.

PARAMETER RAM CONTENTS

The parameter RAM is 28 bits wide and occupies Addresses 0 to 1023. The parameter RAM is initialized to all 0s on power-up. The data format of the parameter RAM is twos complement 5.23. This means that the coefficients may range from +16.0 (minus 1 LSB) to –16.0, with 1.0 represented by the binary word 0000 1000 0000 0000 0000 0000 0000.

Options for Parameter Updates

The parameter RAM can be written and read using one of the two following methods.

1. **Direct Read/Write.** This method allows direct access to the program and parameter RAMs. This mode of operation is normally used during a complete new load of the RAMs, using burst mode addressing. The clear register bit in the core control register should be set to 0 using this mode to avoid any clicks or pops in the outputs. Note that it is also possible to use this mode during live program execution, but since there is no handshaking between the core and the control port, the parameter RAM is unavailable to the DSP core during control writes, resulting in clicks and pops in the audio stream.
2. **Safeload Write.** Up to five safeload registers can be loaded with parameter RAM address/data. The data is then transferred to the requested address when the RAM is not busy. This method can be used for dynamic updates while live program material is playing through the AD1940/AD1941. For example, a complete update of one biquad section can occur in one audio frame, while the RAM is not busy. This method is not available for writing to the program RAM or control registers.

The following sections discuss these two options in more detail.

RECOMMENDED PROGRAM/PARAMETER LOADING PROCEDURES

When writing large amounts of data to the program or parameter RAM in direct write mode, the processor core should be disabled to prevent unpleasant noises from appearing at the audio output. The AD1940/AD1941 contain several mechanisms for disabling the core.

If the loaded program does not use the target/slew RAM as the main system volume control (for example, the default power-up program),

1. Assert Bit 9 (low to assert—default setting) and Bit 6 (high to assert) of the core control register. This zeroes the accumulators, the serial output registers, and the serial input registers.
2. Fill the program RAM using burst mode writes.
3. Fill the parameter RAM using burst mode writes.
4. Assert Bit 7 of the core control register to initiate a data-memory clear sequence. Wait at least 100 μ s for this sequence to complete. This bit is automatically cleared after the operation is complete.
5. Deassert Bit 9 and Bit 6 of the core control register to allow the core to begin normal operation

If the loaded program does use the target/slew RAM as the main system volume control,

1. Assert Bit 12 of the core control register. This begins a volume ramp down, with a time constant determined by the upper bits of the target RAM. Wait for this ramp down to complete (the user may poll Bit 13 of the core control register, or simply wait for a given amount of time).
2. Assert Bit 9 (low to assert) and Bit 6 (high to assert) of the core control register. This zeroes the accumulators, the serial output registers, and the serial input registers.
3. Fill the program RAM using burst mode writes.
4. Fill the parameter RAM using burst mode writes.
5. Assert Bit 7 of the core control register to initiate a data-memory clear sequence. Wait at least 100 μ s for this sequence to complete. This bit is automatically cleared after the operation is complete.
6. Deassert Bit 9 and Bit 6 of the core control register.
7. If the newly loaded program also uses the target/slew RAM, deassert Bit 12 of the core control register to begin a volume ramp up procedure.

TARGET/SLEW RAM

The target/slew RAM is a bank of 64 RAM locations, each of which can be set to autoramp from one value to a desired final value in one of four modes.

Summary

The target/slew RAM is used by the DSP when a program is loaded into the program RAM that uses one or more locations in the slew RAM to access internal coefficient data. Typically, these coefficients are used for volume controls or smooth cross-fading effects, but may be used to update any value in the parameter RAM. Each of the 64 locations in the slew RAM are linked to corresponding locations in the target RAM. When a new value is written to the target RAM using the control port, the corresponding slew RAM location begins to ramp toward the target. The value is updated once per audio frame (LRCLK period).

The target RAM is 34 bits wide. The lower 28 bits contain the target data in 5.23 format for the linear and exponential (constant dB and RC type) ramp types. For constant time ramping, the lower 28 bits contain 16 bits in 2.14 format and 12 bits to set the current step. The upper six bits are used to determine the type and speed of the ramp envelope in all modes. The format of the data write for linear and exponential formats is shown in Table 19. Table 20 shows the data write format for the constant time ramping.

Data can only be written to the target/slew RAM using the safeload registers as described in the Safeload Registers section. A mute slew RAM bit is included in the core control register to simultaneously set all the slew RAM target values to 0. This is useful for implementing a global multichannel mute. When this bit is deasserted, all slew RAM values return to their original premuted states.

Table 19. Linear, Constant dB, and RC Type Ramp Data Write

Byte 0	Byte 1	Bytes 2–4
000000, curve_type [1:0]	time_const [3:0], data [27:24]	Data [23:0]

Table 20. Constant Time Ramp Data Write

Byte 0	Byte 1	Bytes 2–4
000000, curve_type [1:0]	update_step [0], #_of_steps [2:0], data [15:12]	Data [11:0], reserved [11:0]

The four ramping curve types are

- Linear—Value slews to target using a fixed step size.
- Constant dB—Value slews to target using the current value to calculate the step size. The resulting curve has a constant rise and decay when measured in dB.
- RC type—Value slews to target using the difference between target and current values to calculate the step size, producing a simple RC type curve for rising and falling.
- Constant Time—Value slews to the target in a fixed number of steps in a linear fashion. The control port mute has no affect on this type.

Table 21. Target/Slew RAM Ramp Type Settings

Setting	Ramp Type
00	Linear
01	Constant dB
10	RC type
11	Constant time

The following sections detail how the control port writes to the target/slew RAM to control the time constant and ramp type parameters.

Ramp Types 1 to 3: Linear, Constant dB, RC Type (34-Bit Write)

The target word for the first three ramp types is broken up into three parts. The 34-bit command is written with six leading 0s to extend the data write to five bytes. The parts of the target RAM write are the following:

- Ramp Type (2 bits)
- Time Constant (4 bits)
0000 = Fastest
1111 = Slowest
- Data (28 Bits): 5.23 Format

Ramp Type 4—Constant Time (34-Bit Write)

The target word for the constant time ramp type is written in five parts, with the 34-bit command again written with six leading zeros to extend the data write to five bytes. The parts of the constant time target RAM write are the following:

- Ramp Type (2 bits).
- Update Step (1 bit). Set to 1 when new target is loaded to trigger step value update. Value is automatically reset after the step value is updated.
- Number of Steps (3 bits). The number of steps that it takes to slew to the target value is set by these three bits, with the number of steps equal to $2^{3\text{-bit setting} + 6}$.
000 = 64
001 = 128
010 = 256
011 = 512
100 = 1024
101 = 2048
110 = 4096
111 = 8196

- Data (16 bits). 2.14 format.
- Reserved (12 bits). When writing to the RAM, these bits should all be set to 0.

Target and Slew RAM Initialization

On reset, the target/slew RAM initializes to preset values. The target RAM initializes to a linear ramp type with a time constant of 5 and the data set to 1.0. The slew RAM initializes to a value of 1.0. These defaults give a full-scale (1.0 to 0.0) ramp time of 21.3 ms.

Linear Update Math

Linear math is the addition or subtraction of a constant value (step). The equation to describe this step size is

$$step = \frac{2^{13}}{10^{2 \times (const - 5)}} \times \frac{1}{20}$$

The result of the equation is normalized to a 5.23 data format. This gives a time constant range from 6.75 ms to 213.4 ms (–60 dB relative to 0 dB full scale). An example of this kind of update is shown in Figure 15 and Figure 16. All slew RAM figure examples, except the half-scale constant time ramp plot, show an increasing or decreasing ramp between –80 dB and 0 dB (full scale). All figures except the constant time plots (Figure 19 and Figure 21) use a time constant of 0x7 (0x0 being the fastest and 0xF being the slowest).

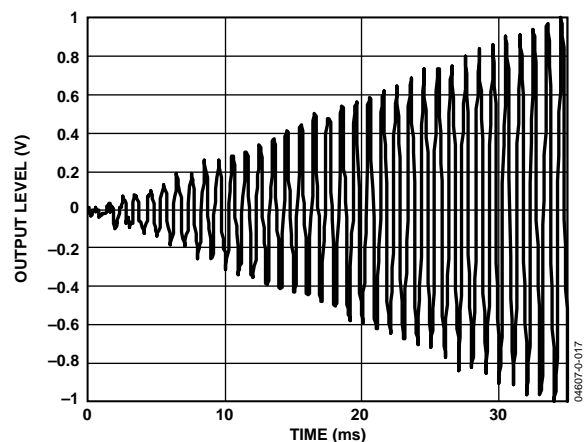

Figure 15. Slew RAM—Linear Update Increasing Ramp

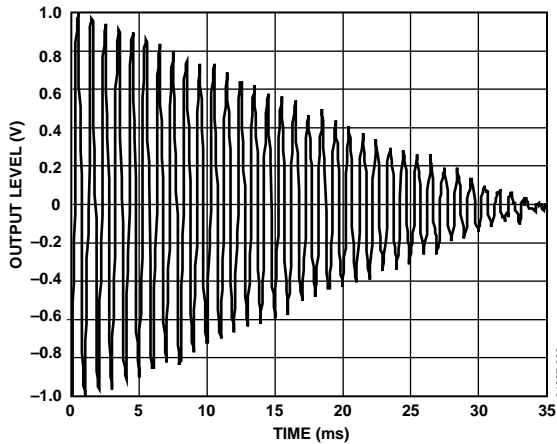

Figure 16. Slew RAM—Linear Update Decreasing Ramp

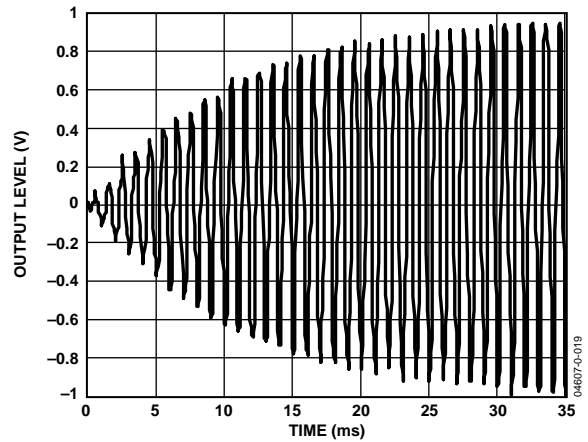

Figure 18. Slew RAM—RC Type Update Increasing Ramp

Constant dB and RC Type (Exponential) Update Math

Exponential math is accomplished by shifts and adds with a range from 6.1 ms to 1.27 s (–60 dB relative to 0 dB full scale). When the ramp type is set to 01 (constant dB), each step size is set to the current value in the slew data. When the ramp type bits are set to 10 (RC type), the step sizes are equal to the difference between the values in the target RAM and slew RAM. Figure 17 and Figure 18 show examples of this type of target/slew RAM ramping. A decreasing ramp of both the constant dB and RC type ramps is a mirror image of the constant dB increasing ramp, and is show in Figure 19.

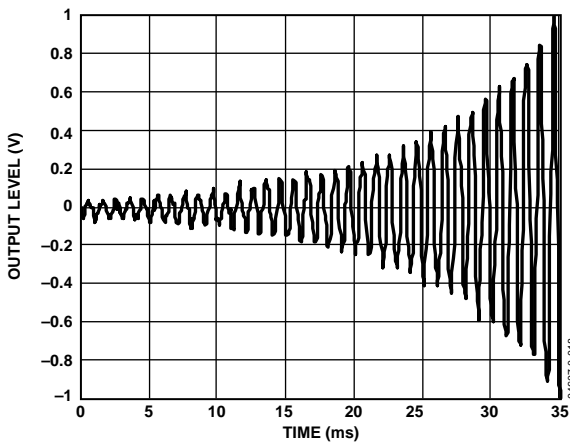

Figure 17. Slew RAM—Constant dB Update Increasing Ramp

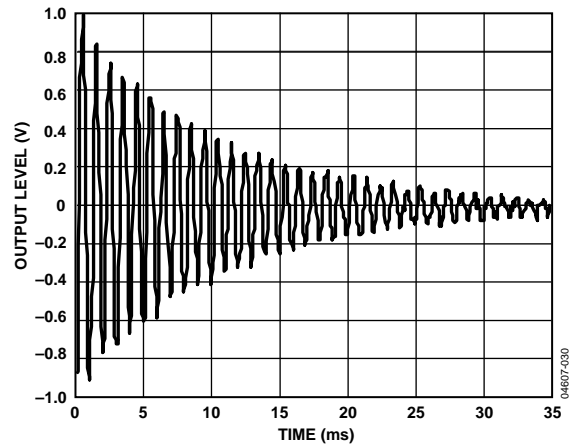

Figure 19. Slew RAM—Constant dB and RC Type Update Decreasing Ramp, Full Scale

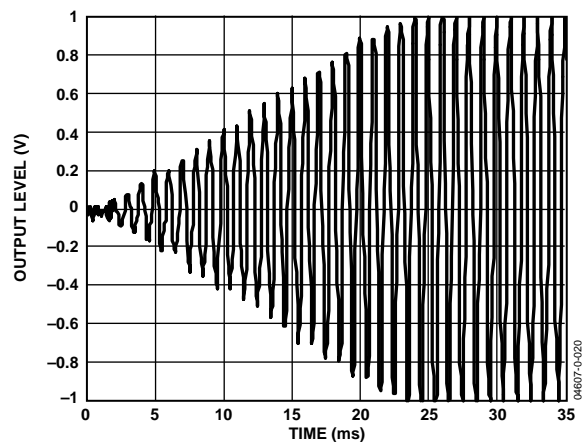

Figure 20. Slew RAM—Constant Time Update Increasing Ramp, Full Scale

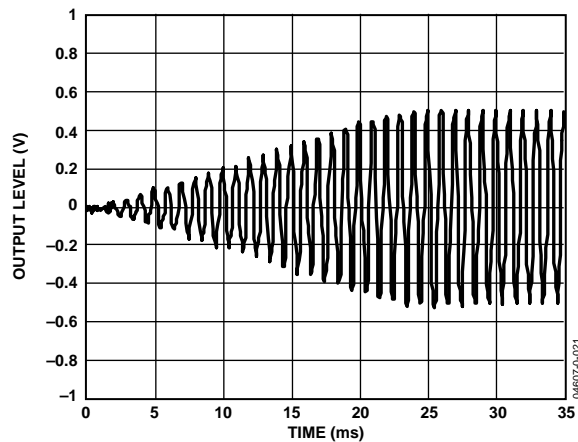

Figure 21. Slew RAM—Constant Time Update Increasing Ramp, Half Scale

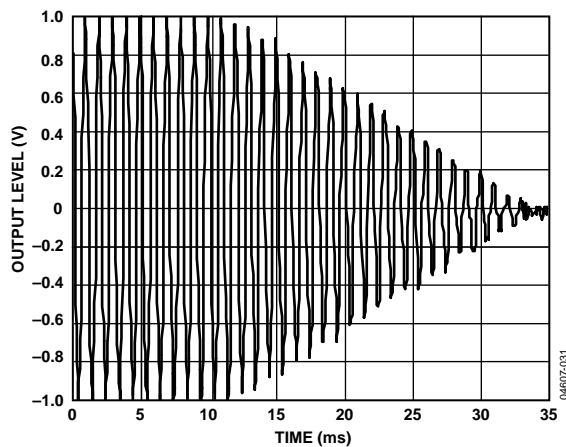

Figure 22. Slew RAM—Constant Time Update Decreasing Ramp, Full Scale

Constant Time Update Math

Constant time math is accomplished by adding a step value that is calculated after each new target is loaded. The equation for this step size is

$$\text{Step} = (\text{Target Data} - \text{Slew Data}) / (\text{Number of Steps})$$

Figure 20 shows a plot of the target/slew RAM operating in constant time mode. For this example, 128 steps are used to reach the target value. This type of ramping takes a fixed amount of time for a given number of steps, regardless of the difference in the initial state and the target value. Figure 21 shows a plot of a constant time ramp from -80 dB to -6 dB (half scale) using 128 steps. You can see that the ramp takes the same amount of time as the previous ramp from -80 dB to 0 dB. A constant time decreasing ramp plot is shown in Figure 21.

SAFELOAD REGISTERS

Many applications require real time control of signal processing parameters, such as filter coefficients, mixer gains, multichannel virtualizing parameters, or dynamics processing curves. To prevent instability from occurring, all of the parameters of a biquad filter must be updated at the same time. Otherwise, the filter could execute for one or two audio frames with a mix of

old and new coefficients. This mix could cause temporary instability, leading to transients that could take a long time to decay. To eliminate this problem, the AD1940/AD1941 load a set of 10 registers in the control port (five for 28-bit parameters, and another five for indirectly addressing the target/slew RAMs) with the desired parameter or target/slew RAM address and data. Five registers are used because a biquad filter uses five coefficients and it is desirable to be able to do a complete biquad update in one transaction. The safeload registers can be used to update either the parameter RAM or target/slew RAM values. Once these registers are loaded, the appropriate initiate safe transfer bit (there are separate bits for parameter and target/slew loads) in the core control register should be set to initiate the loading into RAM. Program lengths should be limited to 1,531 cycles ($1,536 - 5$) to ensure that the SigmaDSP is able to perform the safeloads. It can be guaranteed that the safeload will have occurred within one LRCLK period ($21 \mu\text{s}$ at $f_s = 48 \text{ kHz}$) of the initiate safe transfer bit being set.

The safeload logic automatically sends only those safeload registers that have been written to since the last safeload operation. For example, if only two parameters are to be sent, only two of the five safeload registers must be written to. When the initial safe transfer bit (in the core control register) is asserted, only those two registers are sent; the other three registers are not sent to the RAM and can still hold old or invalid data.

Table 22. Data Capture Control Registers (2634–2641)

Register Bits	Function
12:2	11-Bit program counter address
1:0	Register select 00 = Mult_X_input 01 = Mult_Y_input 10 = MAC_output 11 = Accum_fback

DATA CAPTURE REGISTERS

The AD1940/AD1941's data capture feature allows the data at any node in the signal processing flow to be sent to one of six control port-readable registers or to a serial output pin. This can be used to monitor and display information about internal signal levels or compressor/limiter activity.

The AD1940/AD1941 contain six independent control port-readable data capture registers, and two digital output capture registers. The digital output registers are output on SDATA_OUT7 when the data capture serial out enable bit (Bit 14) is set in serial output Control Register 2. These registers are useful when debugging the signal processing flow.

For each of the data capture registers, a capture count and a register select must be set. The capture count is a number between 0 and 1,535 that corresponds to the program step number where the capture occurs. The register select field programs one of four registers in the DSP core that is transferred to the data capture register when the program

AD1940/AD1941

counter equals the capture count. The register select field selections are shown in Table 23.

Table 23. Data Capture Output Register Select

Setting	Register
00	Multiplier X input (Mult_X_input)
01	Multiplier Y input (Mult_Y_input)
10	Multiplier-Accumulator Output (MAC_out)
11	Accumulator Feedback (Accum_fback)

The capture count and register select bits are set by writing to one of the eight data capture registers at the following register addresses:

- 2634: Control Port Data Capture Setup Register 0
- 2635: Control Port Data Capture Setup Register 1
- 2636: Control Port Data Capture Setup Register 2
- 2637: Control Port Data Capture Setup Register 3
- 2638: Control Port Data Capture Setup Register 4
- 2639: Control Port Data Capture Setup Register 5
- 2640: Digital Out Data Capture Setup Register 0
- 2641: Digital Out Data Capture Setup Register 1

The captured data is in 5.19 twos complement data format for all eight register select fields. The four LSBs are truncated from the internal 5.23 data-word.

The data that must be written to set up the data capture is a concatenation of the 11-bit program count index with the 2-bit register select field. The capture count and register select values that correspond to the desired point to be monitored in the signal processing flow can be found in a file output from the program compiler. The capture registers can be accessed by reading from locations 2634 to 2639 (for control port capture registers). The format for reading and writing to the data capture registers can be seen in Table 32 and Table 33.

DSP CORE CONTROL REGISTER

The controls in this register set the operation of the AD1940/AD1941's DSP core. Bits 6 to 9 can be set to initiate a shutdown of the core. The output is muted when this is performed, so it is best to first assert the mute slew RAM bit (if slew RAM locations are used as volume controls in the program) to avoid a click or pop when shutdown is asserted.

Slew RAM Muted (Bit 13)

This bit is set to 1 when the slew RAM mute operation has been completed. This bit is read-only and is automatically cleared by reading.

Mute Slew RAM, All Locations (Bit 12)

Setting this bit to 1 initiates a mute of all 64 slew RAM locations. When reset to 0, all RAM locations return to their previous state. This bit is only functional if slew RAM locations are used in the custom program design. Keep in mind that the AD1940/AD1941's default program does not use any slew RAM volume controls, so this bit has no effect in that case. The mute

operation is identical to writing all 0s to the data portion of the target RAM, and therefore the time constant and linear/exponential curve selection is determined by the bits that have been previously written to the high bits of the target RAM.

Table 24. DSP Core Control Register (2642)

Register Bits	Function
15:14	Reserved
13	Slew RAM muted (read-only)
12	Mute slew RAM, all locations
11	Reserved, set to 0
10	Use serial out LRCLK for output latch
9	Clear internal registers to all 0s, active low
8	Force multiplier to 0
7	Initialize data memory with 0s
6	Mute serial input port
5	Initiate safe transfer to target RAM
4	Initiate safe transfer to parameter RAM
3:2	Input serial port to sequencer sync 00 = LRCLK 01 = LRCLK/2 10 = LRCLK/4 11 = LRCLK/8
1:0	Program length 00 = 1536 01 = 768 10 = 384 11 = 192

Use Serial Out LRCLK for Output Latch (Bit 10)

Normally, data is transferred from the DSP core to the serial output registers at the end of each program cycle. In some cases (for example, when the output sample rate is set to some multiple of the input sampling rate), it is desirable to transfer the internal core data multiple times during a single input audio sample period. Setting this bit to 1 allows the output LRCLK signal to control this data transfer rather than the internal end-of-sequence signal. Operation in this mode may require custom assembly language coding in the ADI graphical tools.

Clear Registers to All Zeros (Bit 9)

Setting this bit to 0 sets the contents of the accumulators and serial output registers to 0. Like the other register bits, this one powers up to 0. This means the AD1940/AD1941 power up in clear mode and do not pass a signal until a 1 is written to this bit. This is intended to prevent noise from inadvertently occurring during the power-up sequence.

Force Multiplier to Zero (Bit 8)

When this bit is set to 1, the input to the DSP multiplier is set to 0, which results in the multiplier output being 0. This control bit is included for maximum flexibility and is normally not used.

Initialize Data Memory with Zeros (Bit 7)

Setting this bit to 1 initializes all data memory locations to 0. This bit is cleared to 0 after the operation is complete. This bit should be asserted after a complete program/parameter download has occurred to ensure click-free operation.

Zero Serial Input Port (Bit 6)

When this bit is set to 1, the 16 serial input channels are forced to all 0s.

Initiate Safe Transfer to Target RAM (Bit 5)

Setting this bit to 1 initiates a safeload transfer to the target/slew RAM. This bit clears when the operation is completed. Of five safeload register pairs (address/data), only those registers that have been written since the last safeload event are transferred. Address 0 corresponds to the first target RAM location.

Initiate Safe Transfer to Parameter RAM (Bit 4)

Setting this bit to 1 initiates a safeload transfer to the parameter RAM. This bit clears when the operation is completed. Of five safeload registers pairs (address/data), only those registers that have been written since the last safeload event are transferred. Address 0 corresponds to the first parameter RAM location.

Input Serial Port to Sequencer Sync (Bits 3:2)

Normally, the internal sequencer is synchronized to the incoming audio frame rate by comparing the internal program counter with the edge of the LRCLK input signal. In some cases the AD1940/AD1941 may be used to decimate an incoming signal by some integer factor. In this case, it is desirable to synchronize the sequencer to a submultiple of the incoming LRCLK rate so more than one audio input sample is available to the program during a single audio output frame. For example, if these bits are set to 01 (LRCLK/2), a 96 kHz input can be used with a 48 kHz output, allowing two consecutive input samples to be processed during a single audio output frame. Operation in this mode may require custom assembly language coding in the ADI graphical tools.

Program Length (Bits 1:0)**96 kHz and 192 kHz Modes**

These bits set the length of the internal program. The default program length is 1,536 instructions for $f_s = 48$ kHz, but the program length can be shortened by factors of 2 to accommodate sample rates higher than 48 kHz. For $f_s = 96$ kHz, the program length should be set to 768 (01). For $f_s = 192$ kHz, the program length should be set to 384 steps (10). A program length of 192 steps is available, but is not commonly used.

Low Power Mode

This setting can also be used to reduce the power consumption of the AD1940/AD1941. If the program length is set to 768 steps and $f_s = 48$ kHz instead of 96 kHz, then the power

consumption of the part is cut approximately in half.

Correspondingly, when the program length is set to 384 steps with $f_s = 48$ kHz, the power consumption is about $\frac{1}{4}$ of what it is in normal operation with 1,536 program steps and $f_s = 48$ kHz.

Table 25. RAM Configuration Register (2643)

Register Bits	Function
7:4	Reserved
3:0	RAM modulo, 1 LSB corresponds to 512 locations, max = 0b1100 (6 k words)

RAM CONFIGURATION REGISTER

The AD1940/AD1941 use a modulo RAM addressing scheme to allow filters and other blocks to be coded easily without requiring filter data to be explicitly moved during the filtering operation. This is accomplished by adding the contents of an address offset counter to the actual base address supplied in the AD1940/AD1941's cores. This address offset counter is incremented automatically at the audio frame rate.

This method works well for most audio applications that involve filtering. In some cases, however, it is desirable to have direct access to the RAM, bypassing the autoincrementing address offset counter. For this reason, the data memories in the AD1940/AD1941 can be divided into modulo and nonmodulo portions by programming the RAM configuration register (Table 25). The address range from 0 to $512 \times$ (RAM configuration register contents) is treated as modulo memory with autoincrementing address offset registers. The maximum setting of this register is the full size of the RAM, or 6,144 (6 k words) data words. Note that addresses in this range automatically wrap around the modulo boundary as set by the register. This feature is not normally used with ADI supplied blocks. For normal operation, this register may be left in its default state, which sets up the entire RAM to use the autoincrement feature. This feature is included for maximum programming flexibility and may be used in the case of special software development.

CONTROL PORT READ/WRITE DATA FORMATS

The read/write formats of the control port are designed to be byte oriented. This allows easy programming of common microcontroller chips. In order to fit into a byte-oriented format, 0s are appended to the data fields before the MSB in order to extend the data word to the next multiple of eight bits. For example, 28-bit words written to the parameter RAM are appended with four leading 0s to reach 32 bits (four bytes); 40-bit words written to the program RAM are not appended with any 0s because it is already a full 5 bytes. These zero extended data fields are appended to a 3-byte field consisting of a 7-bit chip address, a read/write bit, and an 11-bit RAM/register address. The control port knows how many data bytes to expect based on the address that is received in the first three bytes.

AD1940/AD1941

The total number of bytes for a single location write command can vary from four bytes (for a control register write), to eight bytes (for a program RAM write). Burst mode may be used to fill contiguous register or RAM locations. A burst mode write is done by writing the address and data of the first RAM/register location to be written. Rather than ending the control port transaction (by bringing the CLATCH signal high in the

AD1940/AD1941, after the data word, as would be done in a single address write, the next data word can be written immediately without first writing its specific address). The AD1940/AD1941 control ports autoincrement the address of each write, even across the boundaries of the different RAMs and registers.

Table 26. Parameter RAM Read/Write Format (Single Address)

Byte 0	Byte 1	Byte 2	Byte 3	Bytes 4-6
chip_adr [6:0], W/R	0000, param_adr [11:8]	param_adr [7:0]	0000, param [27:24]	param [23:0]

Table 27. Parameter RAM Block Read/Write Format (Burst Mode)

Byte 0	Byte 1	Byte 2	Byte 3	Bytes 4-6	Bytes 7-10	Bytes 11-14 ¹
chip_adr [6:0], W/R	0000, param_adr [11:8]	param_adr [7:0]	0000, param [27:24]	param [23:0]	0000, param [27:0]	0000, param [27:0]
			<—param_adr—>		param_adr + 1	param_adr + 2

¹ Burst mode data transfers can continue beyond the three words that are illustrated here in the same sequential word format. The register/RAM address auto-increments until the data transfer reaches the IC's last address.

Table 28. Program RAM Read/Write Format (Single Address)

Byte 0	Byte 1	Byte 2	Bytes 3-7
chip_adr [6:0], W/R	0000, prog_adr [11:8]	prog_adr [7:0]	prog [39:0]

Table 29. Program RAM Block Read/Write Format (Burst Mode)

Byte 0	Byte 1	Byte 2	Bytes 3-7	Bytes 8-12	Bytes 13-17 ¹
chip_adr [6:0], W/R	0000, prog_adr [11:8]	prog_adr [7:0]	prog [39:0]	prog [39:0]	prog [39:0]
			<—prog_adr—>	prog_adr + 1	prog_adr + 2

¹ Burst mode data transfers can continue beyond the three words that are illustrated here in the same sequential word format. The register/RAM address auto-increments until the data transfer reaches the IC's last address.

Table 30. Control Register Read/Write Format (Core, Serial Out 0, Serial Out 1)

Byte 0	Byte 1	Byte 2	Byte 3	Byte 4
chip_adr [6:0], W/R	0000, reg_adr [11:8]	reg_adr [7:0]	data [15:8]	data [7:0]

Table 31. Control Register Read/Write Format (RAM Configuration, Serial Input)

Byte 0	Byte 1	Byte 2	Byte 3
chip_adr [6:0], W/R	0000, reg_adr [11:8]	reg_adr [7:0]	data [7:0]

Table 32. Data Capture Register Write Format

Byte 0	Byte 1	Byte 2	Byte 3	Byte 4
chip_adr [6:0], W/R	0000, data_capture_adr [11:8]	data_capture_adr [7:0]	000, progcount [10:6] ¹	progcount [5:0] ¹ , regsel [1:0] ²

¹ Progcount [10:0] = value of program counter where trap occurs (the table of values is generated by the program compiler).

² Regsel [1:0] selects one of four registers (see Data Capture Registers section).

Table 33. Data Capture (Control Port Readback) Register Read Format

Byte 0	Byte 1	Byte 2	Bytes 3–5
chip_adr [6:0], W/R	0000, data_capture_adr [11:8]	data_capture_adr [7:0]	data [23:0]

Table 34. Safeload Register Data Write Format

Byte 0	Byte 1	Byte 2	Byte 3	Bytes 4–7
chip_adr [6:0], W/R	0000, safeload_adr [11:8]	safeload_adr [7:0]	000000, data [33:32]	data [31:0]

Table 35. Safeload Register Address Write Format

Byte 0	Byte 1	Byte 2	Byte 3	Byte 4
chip_adr [6:0], W/R	0000, safeload_adr [11:8]	safeload_adr [7:0]	000000, param_adr [9:8]	param_adr [7:0]

SERIAL DATA INPUT/OUTPUT PORTS

The AD1940/AD1941's flexible serial data input and output ports can be set to accept or transmit data in 2-channel formats or in an 8- or 16-channel TDM stream. Data is processed in twos complement, MSB first format. The left channel data field always precedes the right channel data field in the 2-channel streams. In the TDM modes, Slots 0 to 3 (8-channel TDM) or Slots 0 to 7 (16-channel TDM) fall in the first half of the audio frame, and Slots 4 to 7 (or Slots 8 to 15 in 16-channel TDM) are in the second half of the frame. The serial modes are set in the serial output and serial input control registers.

The input control register allows control of clock polarity and data input modes. The valid data formats are I²S, left-justified, right-justified (24-, 20-, 18-, or 16-bit), 8-channel, and 16-channel TDM. In all modes except for the right-justified modes, the serial port accepts an arbitrary number of bits up to a limit of 24. Extra bits do not cause an error, but they are truncated internally. Proper operation of the right-justified modes requires that there be exactly 64 BCLKs per audio frame. The TDM data is input on SDATA_IN2 and SDATA_IN3 when in 2 × 8-channel TDM mode, and on SDATA_IN2 in 16-channel TDM mode. The LRCLK in TDM mode can be input to the AD1940/AD1941 as either a 50/50 duty cycle clock or as a bit-wide pulse.

The two clock domains on the serial output ports can generate two separate 8-channel TDM streams or one 16-channel TDM stream. When in 16-channel TDM mode, the data is clocked by LRCLK_OUT0 and BCLK_OUT0. The AD1940/AD1941 must be in slave mode for 16-channel TDM mode, unless the data is sampled at 48 kHz; the parts cannot generate a TDM bit clock that is fast enough to support 96 kHz or 192 kHz. In 8-channel TDM mode, the AD1940/AD1941 can be masters for 48 kHz and 96 kHz data, but not for 192 kHz data. Table 36 displays the modes in which the serial output port will function.

The output control registers give the user control of clock polarities, clock frequencies, clock types, and data format. In all modes except for the right-justified modes (MSB delayed by 8, 12, or 16), the serial port accepts an arbitrary number of bits up to a limit of 24. Extra bits do not cause an error, but are truncated internally. Proper operation of the right-justified modes requires the LSB to align with the edge of the LRCLK. The default settings of all serial port control registers correspond to 2-channel I²S mode. LRCLK_OUT0 and BCLK_OUT0 are clocks for Serial Output Ports 0 to 7, and LRCLK_OUT1 and BCLK_OUT1 Clock Ports 8 to 15.

All registers default to being set as all 0s. All register settings apply to both master and slave modes unless otherwise noted.

Table 37 shows the proper configurations for standard audio data formats.

Table 36. Serial Output Port Master/Slave Mode Capabilities

f _s	2-Channel Modes (I ² S, Left-Justified, Right-Justified)	8-Channel TDM	16-Channel TDM
48 kHz	Master and slave	Master and slave	Master and slave
96 kHz	Master and slave	Master and slave	Slave only
192 kHz	Master and slave	Slave only	Slave only

Table 37. Data Format Configurations

Format	LRCLK Polarity	LRCLK Type	BCLK Polarity	MSB Position
I ² S (Figure 23)	Frame begins on falling edge	Clock	Data changes on falling edge	Delayed from LRCLK edge by one BCLK
Left-Justified (Figure 24)	Frame begins on rising edge	Clock	Data changes on falling edge	Aligned with LRCLK edge
Right-Justified (Figure 25)	Frame begins on rising edge	Clock	Data changes on falling edge	Delayed from LRCLK edge by 8, 12, or 16 BCLKs
TDM with Clock (Figure 26)	Frame begins on falling edge	Clock	Data changes on falling edge	Delayed from start of word clock by one BCLK
TDM with Pulse (Figure 27)	Frame begins on rising edge	Pulse	Data changes on falling edge	Delayed from start of word clock by one BCLK

**Table 38. Serial Output Control Register 1
(Channels 0–7) (2644)**

Bits	Function
15	Dither enable 0 = Disabled 1 = Enabled
14	Internally link TDM streams into single, 16-channel stream 0 = Independent 1 = Linked
13	LRCLK polarity 0 = Frame begins on falling edge 1 = Frame begins on rising edge
12	BCLK polarity 0 = Data changes on falling edge 1 = Data changes on rising edge
11	Master/Slave 0 = Slave 1 = Master
10:9	BCLK frequency (master mode only) 00 = core_clock/24 01 = core_clock/12 10 = core_clock/6 11 = core_clock/3
8:7	Frame sync frequency (master mode only) 00 = core_clock/1536 01 = core_clock/768 10 = core_clock/384
6	Frame sync type 0 = LRCLK 1 = Pulse
5	Serial output/TDM mode control 0 = 8 Serial data outputs 1 = Enable TDM (8- or 16-channel) on SDATA_OUT0
4:2	MSB position 000 = Delay by 1 001 = Delay by 0 010 = Delay by 8 011 = Delay by 12 100 = Delay by 16 101 Reserved 111 Reserved
1:0	Output word length, Channels 0–7 00 = 24 bits 01 = 20 bits 10 = 16 bits 11 = Reserved

**Table 39. Serial Output Control Register 2
(Channels 8–15) (2645)**

Bits	Function
15	Dither enable 0 = Disabled 1 = Enabled
14	Data capture serial out enable (Uses SDATA_OUT7) 0 = Disable 1 = Enable
13	LRCLK polarity 0 = Frame begins on falling edge 1 = Frame begins on rising edge
12	BCLK polarity 0 = Data changes on falling edge 1 = Data changes on rising edge
11	Master/Slave 0 = Slave 1 = Master
10:9	BCLK frequency (master mode only) 00 = core_clock/24 01 = core_clock/12 10 = core_clock/6 11 = core_clock/3
8:7	Frame sync frequency (master mode only) 00 = core_clock/1536 01 = core_clock/768 10 = core_clock/384
6	Frame sync type 0 = LRCLK 1 = Pulse
5	Serial output/TDM mode control 0 = 8 serial data outputs 1 = Enable TDM on SDATA_OUT4 (8-channel) or SDATA_OUT0 (16-channel)
4:2	MSB position 000 = Delay by 1 001 = Delay by 0 010 = Delay by 8 011 = Delay by 12 100 = Delay by 16 101 Reserved 111 Reserved
1:0	Output word length, Channels 8–15 00 = 24 bits 01 = 20 bits 10 = 16 bits 11 = Reserved

SERIAL OUTPUT CONTROL REGISTERS

Dither Enable (Bit 15)

Setting this bit to 1 enables dither on the appropriate channels.

Internally Link TDM Streams into Single 16-Channel Stream (Bit 14, Serial Output Control Register 1)

When this bit is set to 1, the TDM output stream is output in a single 16-channel stream on SDATA_OUT0. When set to 0, TDM data is output on two independent 8-channel streams on Pins SDATA_OUT0 and SDATA_OUT4.

Data Capture Serial Out Enable (Bit 14, Serial Output Control Register 2)

When set to 1, SDATA_OUT7 is set as the output of the data capture digital output registers (2640–2641). See the Data Capture Registers section for a full explanation of this mode.

LRCLK Polarity (Bit 13)

When set to 0, the left channel data is clocked when LRCLK is low, and the right data clocked when LRCLK is high. When set to 1, this is reversed.

BCLK Polarity (Bit 12)

This bit controls on which edge of the bit clock the output data is clocked. Data changes on the falling edge of BCLK_OUTx when this bit is set to 0, and on the rising edge when this bit is set at 1.

Master/Slave (Bit 11)

This bit sets whether the output port is a clock master or slave. The default setting is slave; on power-up, Pins BCLK_OUTx and LRCLK_OUTx are set as inputs until this bit is set to 1, at which time they become clock outputs.

BCLK Frequency (Bits 10:9)

When the output port is being used as a clock master, these bits set the frequency of the output bit clock, which is divided down from the internal 73.728 MHz core clock.

Frame Sync Frequency (Bits 8:7)

When the output port is used as a clock master, these bits set the frequency of the output word clock on the LRCLK_OUTx pins, which is divided down from the internal 73.728 MHz core clock.

Frame Sync Type (Bit 6)

This bit sets the type of signal on the LRCLK_OUTx pins. When set to 0, the signal is a word clock with a 50% duty cycle; when set to 1, the signal is a pulse with a duration of one bit clock at the beginning of the data frame.

Serial Output/TDM Mode Control (Bit 5)

Setting this bit to 1 changes the output port from multiple serial outputs to a single TDM output stream on the appropriate SDATA_OUTx pin. This bit must be set in both serial output control registers to enable 16-channel TDM on SDATA_OUT0.

MSB Position (Bits 4:2)

These three bits set the position of the MSB of data with respect to the LRCLK edge. The data outputs of the AD1940/AD1941 are always MSB first.

Output Word Length (Bits 1:0)

These bits set the word length of the output data-word. All bits following the LSB are set to 0.

Table 40. Serial Input Control Register (2646)

Register Bits	Function
5	8-/16-channel TDM input 0 = Dual 8-channel TDM 1 = 16-channel TDM input
4	LRCLK polarity 0 = Frame begins on falling edge 1 = Frame begins on rising edge
3	BCLK polarity 0 = Data changes on falling edge 1 = Data changes on rising edge
2:0	Serial input mode 000 = I ² S 001 = Left-justified 010 = TDM 011 = Right-justified, 24-bit 100 = Right-justified, 20-bit 101 = Right-justified, 18-bit 110 = Right-justified, 16-bit

SERIAL INPUT CONTROL REGISTER

8-/16-Channel TDM Input (Bit 5)

Setting this bit to 0 puts the AD1940/AD1941 into dual 8-channel TDM input mode, with the two streams coming in on SDATA_IN2/TDM_IN1 and SDATA_IN3/TDM_IN0. Channels 0 to 7 are input on TDM_IN0 and Channels 8 to 15 come in on TDM_IN1. Setting this bit to 1 puts the part in 16-channel TDM input mode, input on TDM_IN1.

LRCLK Polarity (Bit 4)

When set to 0, the left channel data on the SDATA_INx pins is clocked when LRCLK_IN is low; the right input data clocked when LRCLK_IN is high. When set to 1, this is reversed. In TDM mode, when this bit is set to 0, data is clocked in starting with the next appropriate BCLK edge (set in Bit 3 of this register) that follows a falling edge on the LRCLK_IN pin. When set to 1 and running in TDM mode, the input data is valid on the BCLK edge following a rising edge on the word clock (LRCLK_IN). The serial input port can also operate with a pulse input signal, rather than a clock. In this case, the first edge of the pulse is used by the AD1940/AD1941 to start the data frame. When this polarity bit is set to 0, a low pulse should be used, and a high pulse should be used when the bit is set to 1.

BCLK Polarity (Bit 3)

This bit controls on which edge of the bit clock the input data changes, and on which edge it is clocked. Data changes on the falling edge of BCLK_IN when this bit is set to 0, and on the rising edge when this bit is set at 1.

Serial Input Mode (Bits 2:0)

These two bits control the data format that the input port expects to receive. Bits 3 and 4 of this control register override the settings in Bits 2:0, so all four bits must be changed together for proper operation in some modes. The clock diagrams for these modes are shown in Figure 23, Figure 24, and Figure 25. Note that for left-justified and right-justified modes the LRCLK polarity is high, then low, which is opposite from the default setting of Bit 4.

When these bits are set to accept a TDM input, the AD1940/AD1941's data starts after the edge defined by Bit 4. Figure 26 shows an 8-channel TDM stream with a high-to-low triggered LRCLK and data changing on the falling edge of the BCLK. The

AD1940/AD1941 expects the MSB of each data slot delayed by one BCLK from the beginning of the slot, just like in the stereo I²S format. In 8-channel TDM mode, Channels 0 to 3 are in the first half of the frame, and Channels 4 to 7 are in the second half. When in 16-channel TDM mode, the first half-frame holds Channels 0 to 7, and the second half-frame holds Channels 8 to 15. Figure 26 shows just one of the formats in which the AD1940/AD1941 can operate in TDM mode. Please refer to the Serial Data Input/Output Ports section for a more complete description of the modes of operation. Figure 27 shows an example of a TDM stream running with a pulse word clock, which would be used to interface to ADI codecs in their auxiliary mode. To work in this mode on either the input or output serial ports, the AD1940/AD1941 should be set to frame beginning on the rising edge of LRCLK, data changing on the falling edge of BCLK, and MSB position delayed from the start of the word clock by one BCLK.

Table 37 explains the clock settings for each of these formats.

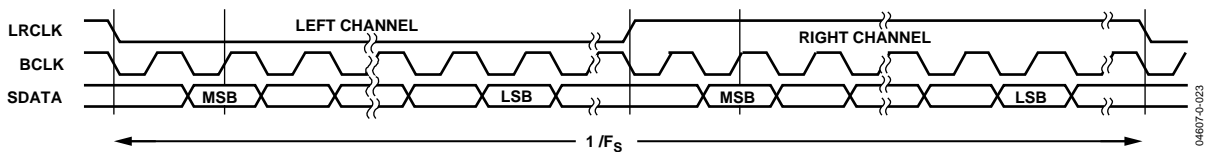

Figure 23. I²S Mode—16 to 24 Bits per Channel

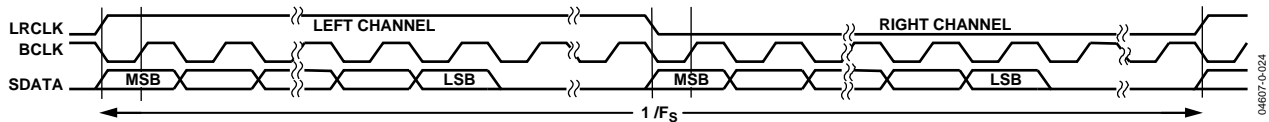

Figure 24. Left-Justified Mode—16 to 24 Bits per Channel

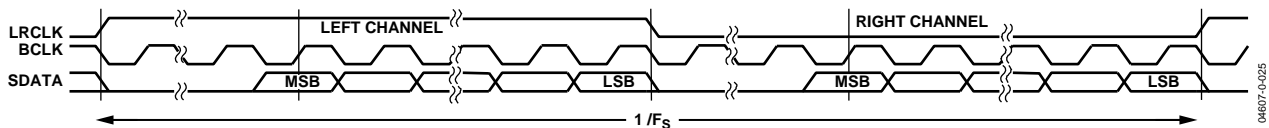
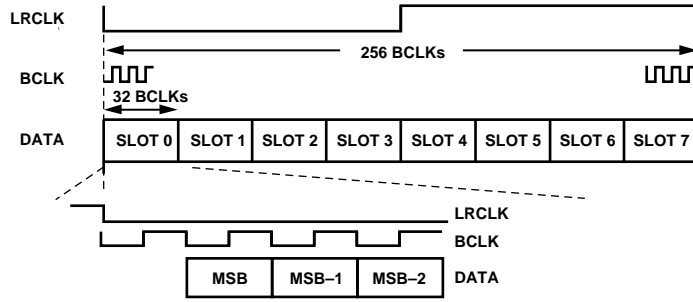
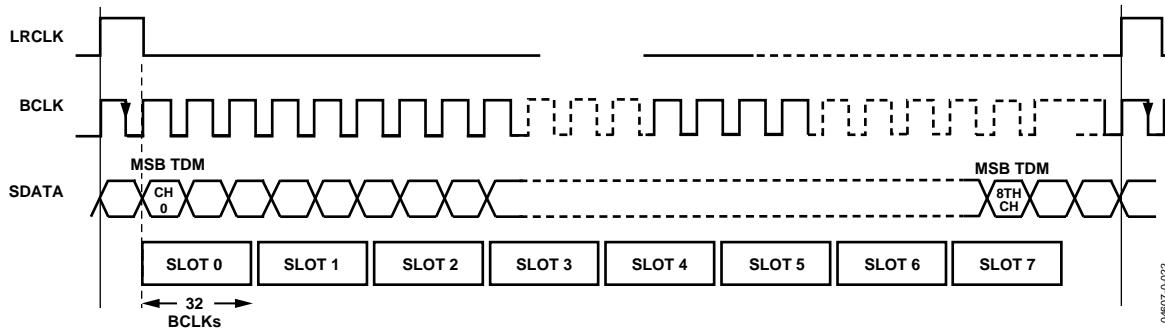

Figure 25. Right-Justified Mode—16 to 24 Bits per Channel



04607-0-012

Figure 26. 8-Channel TDM Mode



04607-0-022

Figure 27. TDM Mode with Pulse Word Clock

INITIALIZATION

POWER-UP SEQUENCE

The AD1940/AD1941 have a built-in power-up sequence that initializes the contents of all internal RAMs. During this time, the contents of the internal program boot ROM are copied to the internal program RAM memory and the parameter RAM (all 0s) is filled with values from its associated boot ROM. The default boot ROM program simply copies the serial inputs to the serial outputs with no processing. The data memories are also cleared during this time.

The boot sequence, which starts on the rising edge of the RESETB pin, lasts for 8,192 cycles of the signal on the MCLK pin at start-up. Assuming even the slowest possible signal on this pin, a $64 \times f_s$ clock, the boot sequence still completes before the PLL locks to the input clock. Since the boot sequence requires a stable master clock, the user should avoid writing to or reading from the registers until the MCLK input signal has settled and the PLL has locked. The PLL takes approximately 3 ms to lock. Coming out of reset, the clock mode is immediately set by the PLL_CTRL0, PLL_CTRL1, and PLL_CTRL2 pins. Reset is synched to the falling edge of the internal MCLK.

The power-up default signal processing flow in the AD1940/AD1941 simply takes the eight inputs and copies these signals to the 16 digital outputs, as shown in Figure 28.

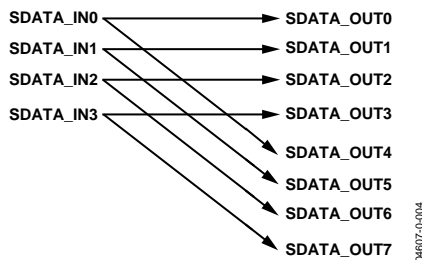

Figure 28. Default Program Signal Flow

SETTING MASTER CLOCK/PLL MODE

The AD1940/AD1941's MCLK input feeds a PLL, which generates the $1536 \times f_s$ clock to run the DSP core. In normal operation, the input to MCLK must be one of the following; $64 \times f_s$, $256 \times f_s$, $384 \times f_s$, or $512 \times f_s$, where f_s is the input sampling rate. The mode is set on PLL_CTRL0, PLL_CTRL1, and PLL_CTRL2, according to Table 41. If the AD1940/AD1941 are set to receive double-rate signals (by reducing the number of program steps/sample by a factor of 2 using the core control register), then the master clock frequencies must be either $32 \times f_s$, $128 \times f_s$, $192 \times f_s$, or $256 \times f_s$. If the AD1940/AD1941 are set to receive quad rate signals (by reducing the number of program steps/sample by a factor of 4 using the core control register), then the master clock frequencies must be $16 \times f_s$, $64 \times f_s$, $96 \times f_s$, or $128 \times f_s$. On power-up, a clock signal must be present on MCLK so that the AD1940/AD1941 can complete their initialization routine. The

PLL can also run in bypass mode, where the clock present on MCLK is fed directly to the DSP core, although this setting is not recommended for normal operation.

Table 41. PLL Modes

MCLK Input	PLL_CTRL2	PLL_CTRL1	PLL_CTRL0
$64 \times f_s$	0	0	0
$256 \times f_s$	0	1	0
$384 \times f_s$	X ¹	X ¹	1
$512 \times f_s$	1	0	0
Bypass	1	1	0

¹ X = don't care

The clock mode should not be changed without also resetting the AD1940/AD1941. If the mode is changed on the fly, a click or pop may result on the outputs. The state of the PLL_CTRLx pins should be changed while RESETB is held low.

VOLTAGE REGULATOR

The AD1940/AD1941 include an on-board voltage regulator that allows the chip to be used in systems where a 2.5 V supply is not available, but 3.3 V or 5 V is. The only external components needed for this are a PNP transistor such as a ZX5T953G, a single capacitor, and a single resistor. The recommended design for the voltage regulator is shown in Figure 29. The 10 μ F and 100 nF capacitors shown in this schematic are recommended for bypassing, but are not necessary for operation. Here, VDD is the main system voltage (3.3 V or 5 V) and should be connected to VSUPPLY. 2.5 V is generated at the transistor's collector, which is connected to the VDD pins, PLL_VDD and VSENSE. The reference voltage on VREF is 1.15 V and is generated by the regulator. A 1 nF capacitor should be connected between this pin and ground. VDRIVE is connected to the base of the PNP transistor. A 1 k Ω resistor should be connected between VDRIVE and VSUPPLY.

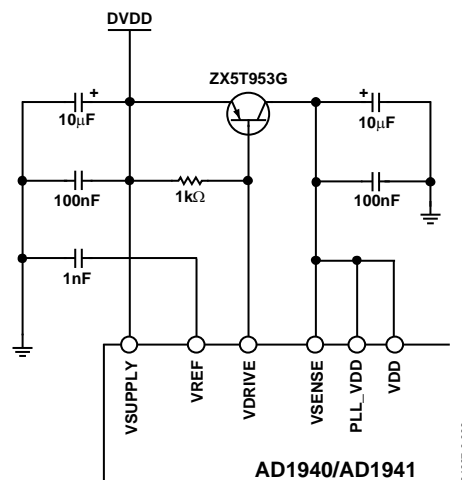

Figure 29. Voltage Regulator Design

AD1940/AD1941

There are two specifications that should be taken into consideration when choosing a regulator transistor. First, the transistor's current amplification factor (h_{FE} or beta) should be at least 100. Second, the transistor's collector needs to be able to dissipate the heat generated when regulating from 3.3 V or 5 V to 2.5 V. The maximum current draw of the AD1940/AD1941 is 163 mA (maximum digital current + maximum PLL current). The equations for the minimum power dissipation specs for both 3.3 V and 5 V follow:

$$(5 \text{ V} - 2.5 \text{ V}) \times 163 \text{ mA} = 480 \text{ mW}$$

$$(3.3 \text{ V} - 2.5 \text{ V}) \times 163 \text{ mA} = 130 \text{ mW}$$

If the regulator is not used in the design, VREF, VDRIVE, and VSENSE can be tied to ground. VSUPPLY should be connected to the same or higher potential as the VDD pin.

OUTLINE DIMENSIONS

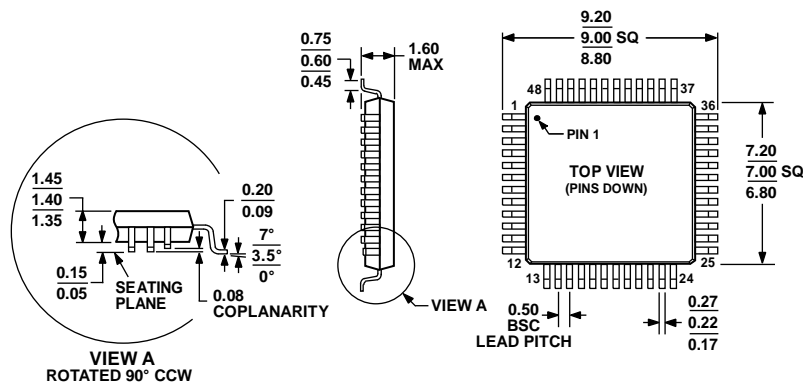

COMPLIANT TO JEDEC STANDARDS MS-026-BBC

Figure 30. 48-Lead Low-Profile Quad Flat Package [LQFP] (ST-48)
Dimensions shown in millimeters

051706-A

ORDERING GUIDE

Model ¹	Temperature Range	Package Description	Package Option
AD1940YSTZ	-40°C to +105°C	48-Lead LQFP	ST-48
AD1940YSTZRL	-40°C to +105°C	48-Lead LQFP, 13" Tape and Reel	ST-48
AD1941YSTZ	-40°C to +105°C	48-Lead LQFP	ST-48
AD1941YSTZRL	-40°C to +105°C	48-Lead LQFP, 13" Tape and Reel	ST-48
Eval-AD1940AZ		Evaluation Board	
Eval-AD1940MINIBZ		Evaluation Board	

¹ Z = RoHS Compliant Part.

NOTES

Purchase of licensed I²C components of Analog Devices or one of its sublicensed Associated Companies conveys a license for the purchaser under the Philips I²C Patent Rights to use these components in an I²C system, provided that the system conforms to the I²C Standard Specification as defined by Philips.

Looking for pricing, stock, or lifecycle information?

Click below to explore more details on WIN SOURCE:

 [View AD1941YSTZ-29 on WIN SOURCE](#)

 [Analog Devices Inc. Information](#)

Optimize Your Supply Chain with WIN SOURCE Solutions

-  Global Sourcing Solution
-  Obsolete Management
-  Cost Control Management
-  Shortage Management
-  Alternative Solution
-  Excess Inventory Management