

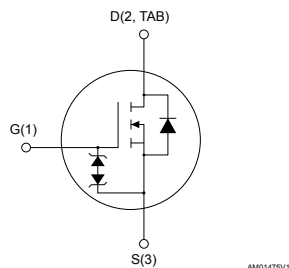

# THE DATASHEET OF STP7N60M2

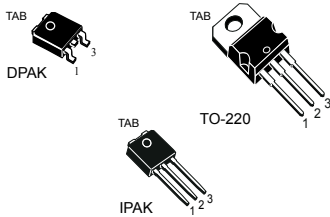

## N-channel 600 V, 0.86 $\Omega$ typ., 5 A, MDmesh™ M2 Power MOSFETs in DPAK, TO-220 and IPAK packages



### Features

Order codes	$V_{DS} @ T_{Jmax}$	$R_{DS(on)}$ max.	$I_D$
STD7N60M2	650 V	0.95 $\Omega$	5 A
STP7N60M2			
STU7N60M2			

- Extremely low gate charge
- Excellent output capacitance ( $C_{OSS}$ ) profile
- 100% avalanche tested
- Zener-protected

### Applications

- Switching applications

### Description

These devices are N-channel Power MOSFETs developed using MDmesh™ M2 technology. Thanks to their strip layout and improved vertical structure, these devices exhibit low on-resistance and optimized switching characteristics, rendering them suitable for the most demanding high efficiency converters.

#### Product status link

[STD7N60M2](#)

[STP7N60M2](#)

[STU7N60M2](#)

#### Product summary

Order code	STD7N60M2
Marking	7N60M2
Package	DPAK
Packing	Tape and reel
Order code	STP7N60M2
Marking	7N60M2
Package	TO-220
Packing	Tube
Order code	STU7N60M2
Marking	7N60M2
Package	IPAK
Packing	Tube

# 1 Electrical ratings

**Table 1. Absolute maximum ratings**

Symbol	Parameter	Value	Unit
$V_{GS}$	Gate-source voltage	$\pm 25$	V
$I_D^{(1)}$	Drain current (continuous) at $T_{case} = 25\text{ }^\circ\text{C}$	5	A
	Drain current (continuous) at $T_{case} = 100\text{ }^\circ\text{C}$	3.5	
$I_{DM}^{(2)}$	Drain current (pulsed)	20	A
$P_{TOT}$	Total dissipation at $T_{case} = 25\text{ }^\circ\text{C}$	60	W
$dv/dt^{(3)}$	Peak diode recovery voltage slope	15	V/ns
$dv/dt^{(4)}$	MOSFET $dv/dt$ ruggedness	50	
$T_{stg}$	Storage temperature range	-55 to 150	$^\circ\text{C}$
$T_j$	Operating junction temperature range		

- Limited by maximum junction temperature.
- Pulse width limited by safe operating area.
- $I_{SD} \leq 5\text{ A}$ ,  $di/dt \leq 400\text{ A}/\mu\text{s}$ ;  $V_{DS\ peak} < V_{(BR)DSS}$ ,  $V_{DD}=400\text{ V}$
- $V_{DS} \leq 480\text{ V}$

**Table 2. Thermal data**

Symbol	Parameter	Value			Unit
		DPAK	TO-220	IPAK	
$R_{thj-case}$	Thermal resistance junction-case	2.08			$^\circ\text{C}/\text{W}$
$R_{thj-pcb}^{(1)}$	Thermal resistance junction-pcb	50			$^\circ\text{C}/\text{W}$
$R_{thj-amb}$	Thermal resistance junction-ambient		62.5	100	$^\circ\text{C}/\text{W}$

- When mounted on 1 inch<sup>2</sup> FR-4, 2 Oz copper board

**Table 3. Avalanche characteristics**

Symbol	Parameter	Value	Unit
$I_{AR}$	Avalanche current, repetitive or non-repetitive (pulse width limited by $T_{Jmax}$ )	1.5	A
$E_{AS}$	Single pulse avalanche energy (starting $T_j = 25\text{ }^\circ\text{C}$ , $I_D = I_{AR}$ , $V_{DD} = 50\text{ V}$ )	99	mJ

## 2 Electrical characteristics

( $T_{\text{case}} = 25\text{ °C}$  unless otherwise specified)

**Table 4. Static**

Symbol	Parameter	Test conditions	Min.	Typ.	Max.	Unit
$V_{(\text{BR})\text{DSS}}$	Drain-source breakdown voltage	$V_{\text{GS}} = 0\text{ V}$ , $I_{\text{D}} = 1\text{ mA}$	600			V
$I_{\text{DSS}}$	Zero gate voltage drain current	$V_{\text{GS}} = 0\text{ V}$ , $V_{\text{DS}} = 600\text{ V}$			1	$\mu\text{A}$
		$V_{\text{GS}} = 0\text{ V}$ , $V_{\text{DS}} = 600\text{ V}$ , $T_{\text{case}} = 125\text{ °C}$ <sup>(1)</sup>			100	
$I_{\text{GSS}}$	Gate-body leakage current	$V_{\text{DS}} = 0\text{ V}$ , $V_{\text{GS}} = \pm 25\text{ V}$			$\pm 10$	$\mu\text{A}$
$V_{\text{GS(th)}}$	Gate threshold voltage	$V_{\text{DS}} = V_{\text{GS}}$ , $I_{\text{D}} = 250\text{ }\mu\text{A}$	2	3	4	V
$R_{\text{DS(on)}}$	Static drain-source on-resistance	$V_{\text{GS}} = 10\text{ V}$ , $I_{\text{D}} = 2.5\text{ A}$		0.86	0.95	$\Omega$

1. Defined by design, not subject to production test.

**Table 5. Dynamic**

Symbol	Parameter	Test conditions	Min.	Typ.	Max.	Unit
$C_{\text{iss}}$	Input capacitance	$V_{\text{DS}} = 100\text{ V}$ , $f = 1\text{ MHz}$ , $V_{\text{GS}} = 0\text{ V}$	-	271	-	$\text{pF}$
$C_{\text{oss}}$	Output capacitance		-	15.7	-	
$C_{\text{riss}}$	Reverse transfer capacitance		-	0.68	-	
$C_{\text{oss eq.}}^{(1)}$	Equivalent output capacitance	$V_{\text{DS}} = 0\text{ to }480\text{ V}$ , $V_{\text{GS}} = 0\text{ V}$	-	75.5	-	$\text{pF}$
$R_{\text{G}}$	Intrinsic gate resistance	$f = 1\text{ MHz}$ , $I_{\text{D}} = 0\text{ A}$	-	7.2	-	$\Omega$
$Q_{\text{g}}$	Total gate charge	$V_{\text{DD}} = 480\text{ V}$ , $I_{\text{D}} = 5\text{ A}$ , $V_{\text{GS}} = 0\text{ to }10\text{ V}$ (see Figure 17. Test circuit for gate charge behavior)	-	8.8	-	$\text{nC}$
$Q_{\text{gs}}$	Gate-source charge		-	1.8	-	
$Q_{\text{gd}}$	Gate-drain charge		-	4.3	-	

1.  $C_{\text{oss eq.}}$  is defined as a constant equivalent capacitance giving the same charging time as  $C_{\text{oss}}$  when  $V_{\text{DS}}$  increases from 0 to 80%  $V_{\text{DSS}}$ .

**Table 6. Switching times**

Symbol	Parameter	Test conditions	Min.	Typ.	Max.	Unit
$t_{\text{d(on)}}$	Turn-on delay time	$V_{\text{DD}} = 300\text{ V}$ , $I_{\text{D}} = 2.5\text{ A}$ , $R_{\text{G}} = 4.7\text{ }\Omega$ , $V_{\text{GS}} = 10\text{ V}$ (see Figure 16. Test circuit for resistive load switching times and Figure 21. Switching time waveform)	-	7.6	-	ns
$t_{\text{r}}$	Rise time		-	7.2	-	
$t_{\text{d(off)}}$	Turn-off delay time		-	19.3	-	
$t_{\text{f}}$	Fall time		-	15.9	-	

**Table 7. Source-drain diode**

Symbol	Parameter	Test conditions	Min.	Typ.	Max.	Unit
$I_{SD}$	Source-drain current		-		5	A
$I_{SDM}^{(1)}$	Source-drain current (pulsed)		-		20	A
$V_{SD}^{(2)}$	Forward on voltage	$V_{GS} = 0\text{ V}$ , $I_{SD} = 5\text{ A}$	-		1.6	V
$t_{rr}$	Reverse recovery time	$I_{SD} = 5\text{ A}$ , $di/dt = 100\text{ A}/\mu\text{s}$ , $V_{DD} = 60\text{ V}$ (see Figure 18. Test circuit for inductive load switching and diode recovery times )	-	275		ns
$Q_{rr}$	Reverse recovery charge		-	1.55		$\mu\text{C}$
$I_{RRM}$	Reverse recovery current		-	11		A
$t_{rr}$	Reverse recovery time	$I_{SD} = 5\text{ A}$ , $di/dt = 100\text{ A}/\mu\text{s}$ , $V_{DD} = 60\text{ V}$ , $T_j = 150\text{ }^\circ\text{C}$ (see Figure 18. Test circuit for inductive load switching and diode recovery times )	-	376		ns
$Q_{rr}$	Reverse recovery charge		-	2.1		$\mu\text{C}$
$I_{RRM}$	Reverse recovery current		-	11		A

1. Pulse width is limited by safe operating area.

2. Pulse test: pulse duration = 300  $\mu\text{s}$ , duty cycle 1.5%.

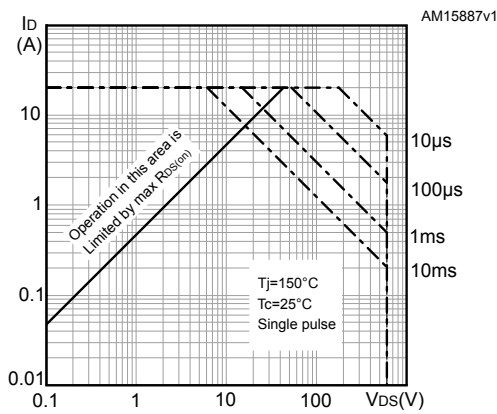
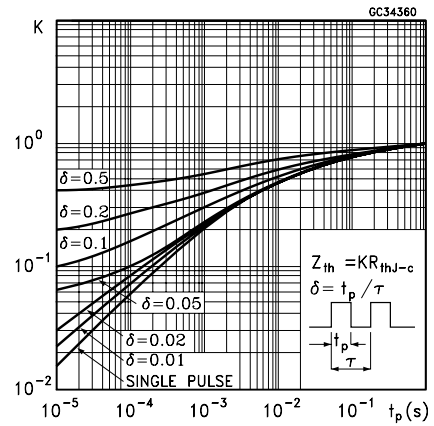
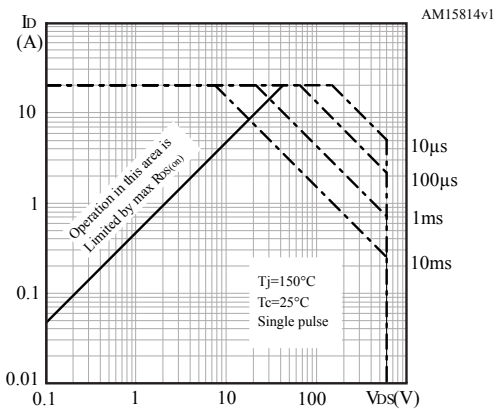
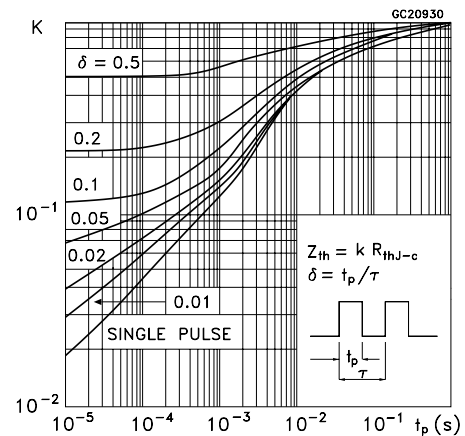
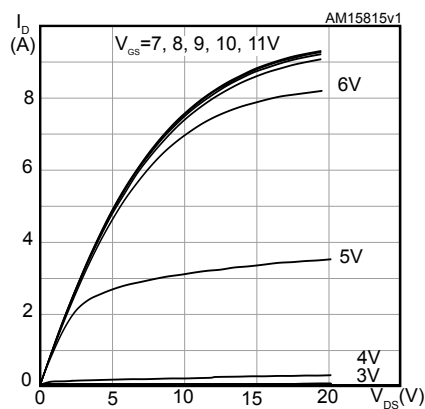
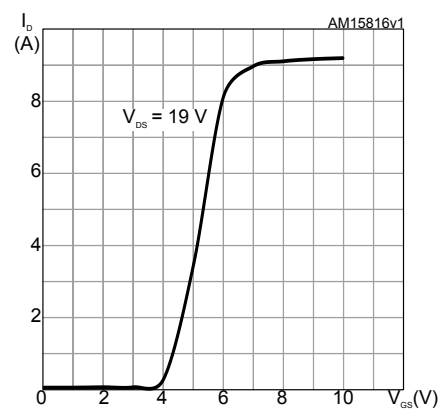
**2.1 Electrical characteristics (curves)**
**Figure 2. Safe operating area for DPAK and IPAK**

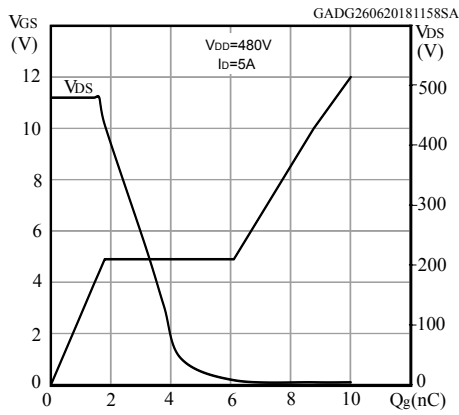
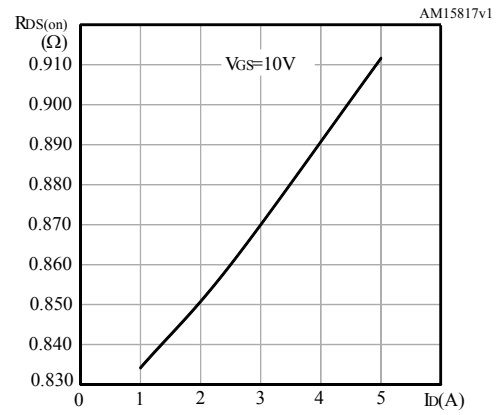
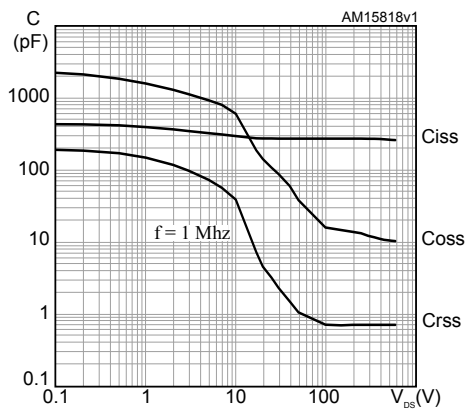
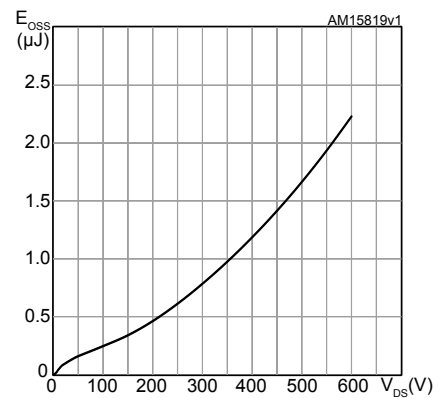
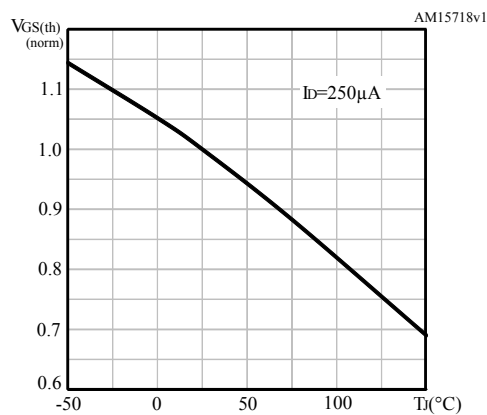
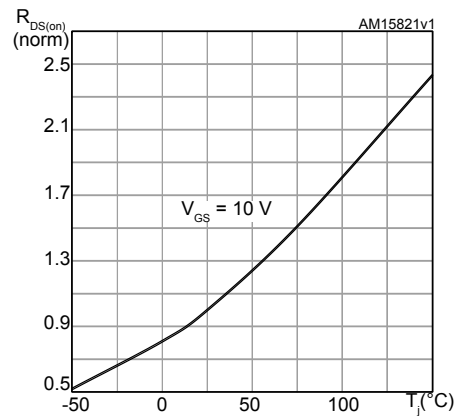
**Figure 3. Thermal impedance for DPAK and IPAK**

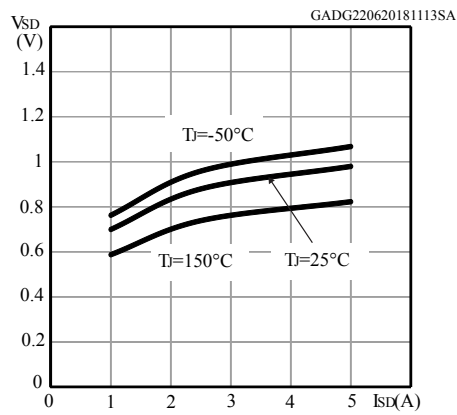
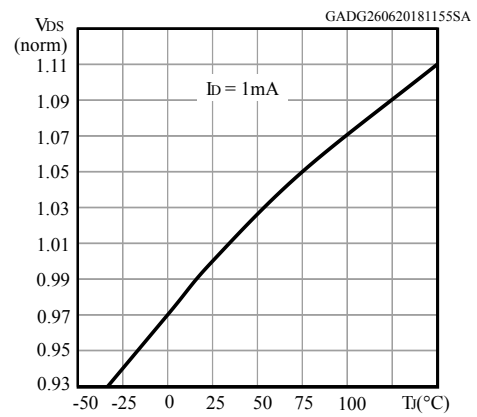
**Figure 4. Safe operating area for TO-220**

**Figure 5. Thermal impedance for TO-220**

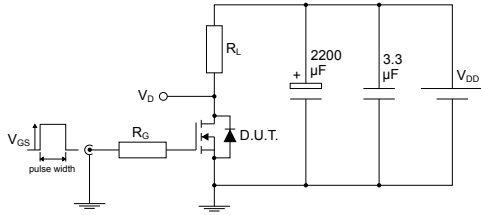
**Figure 6. Output characteristics**

**Figure 7. Transfer characteristics**

**Figure 8. Gate charge vs gate-source voltage**

**Figure 9. Static drain-source on-resistance**

**Figure 10. Capacitance variations**

**Figure 11. Output capacitance stored energy**

**Figure 12. Normalized gate threshold voltage vs temperature**

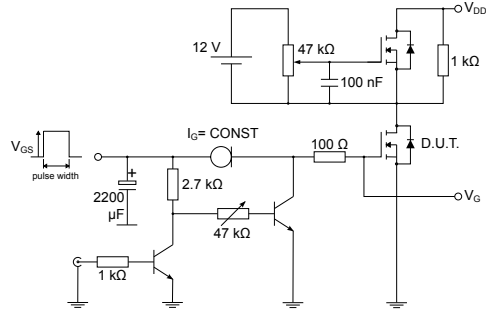
**Figure 13. Normalized on-resistance vs temperature**

**Figure 14. Source-drain diode forward characteristics**

**Figure 15. Normalized  $V_{(BR)DSS}$  vs temperature**

### 3 Test circuits

**Figure 16. Test circuit for resistive load switching times**

AM01468v1

**Figure 17. Test circuit for gate charge behavior**

AM01469v1

**Figure 18. Test circuit for inductive load switching and diode recovery times**

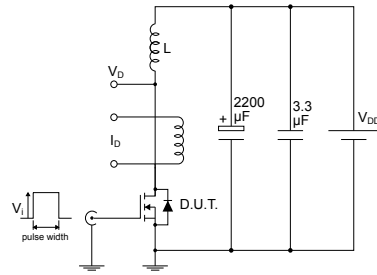

AM01470v1

**Figure 19. Unclamped inductive load test circuit**

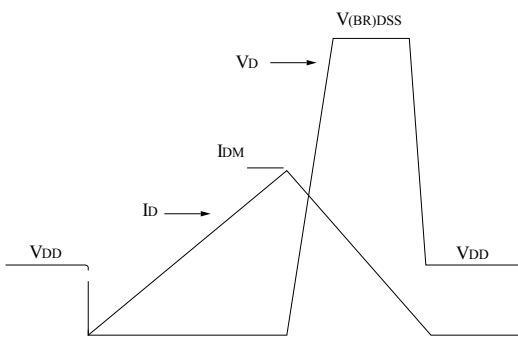
AM01471v1

**Figure 20. Unclamped inductive waveform**

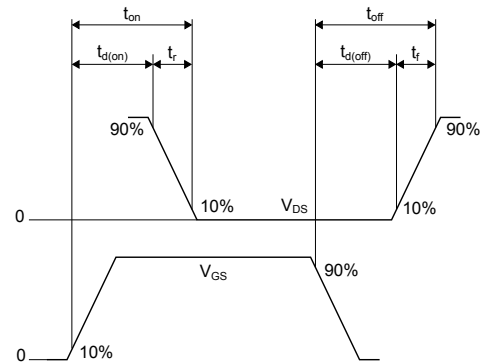
AM01472v1

**Figure 21. Switching time waveform**

AM01473v1

## 4 Package information

---

In order to meet environmental requirements, ST offers these devices in different grades of ECOPACK® packages, depending on their level of environmental compliance. ECOPACK® specifications, grade definitions and product status are available at: [www.st.com](http://www.st.com). ECOPACK® is an ST trademark.

### 4.1 DPAK (TO-252) type A package information

Figure 22. DPAK (TO-252) type A package outline

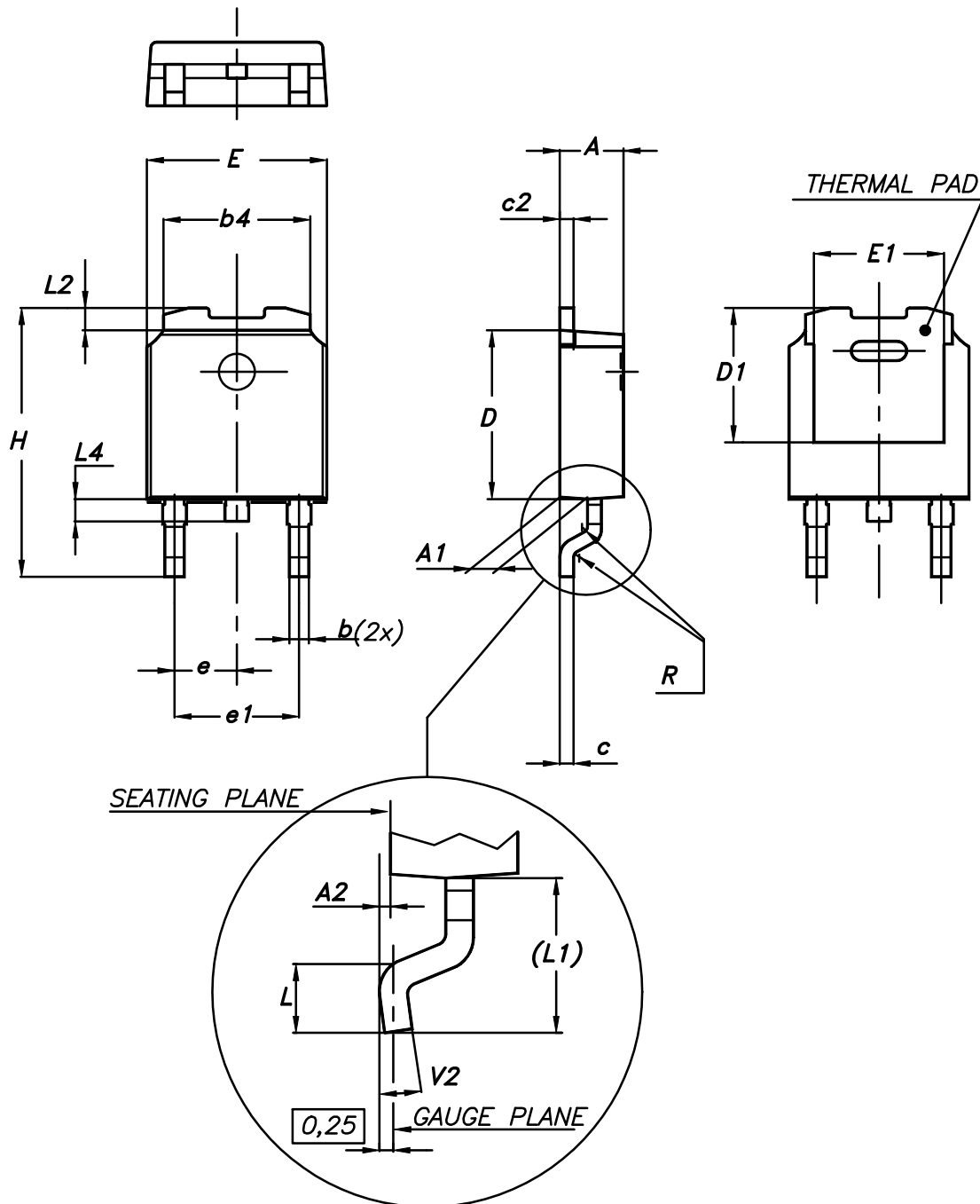

0068772\_A\_25

**Table 8. DPAK (TO-252) type A mechanical data**

Dim.	mm		
	Min.	Typ.	Max.
A	2.20		2.40
A1	0.90		1.10
A2	0.03		0.23
b	0.64		0.90
b4	5.20		5.40
c	0.45		0.60
c2	0.48		0.60
D	6.00		6.20
D1	4.95	5.10	5.25
E	6.40		6.60
E1	4.60	4.70	4.80
e	2.159	2.286	2.413
e1	4.445	4.572	4.699
H	9.35		10.10
L	1.00		1.50
(L1)	2.60	2.80	3.00
L2	0.65	0.80	0.95
L4	0.60		1.00
R		0.20	
V2	0°		8°

## 4.2 DPAK (TO-252) type C package information

Figure 23. DPAK (TO-252) type C package outline

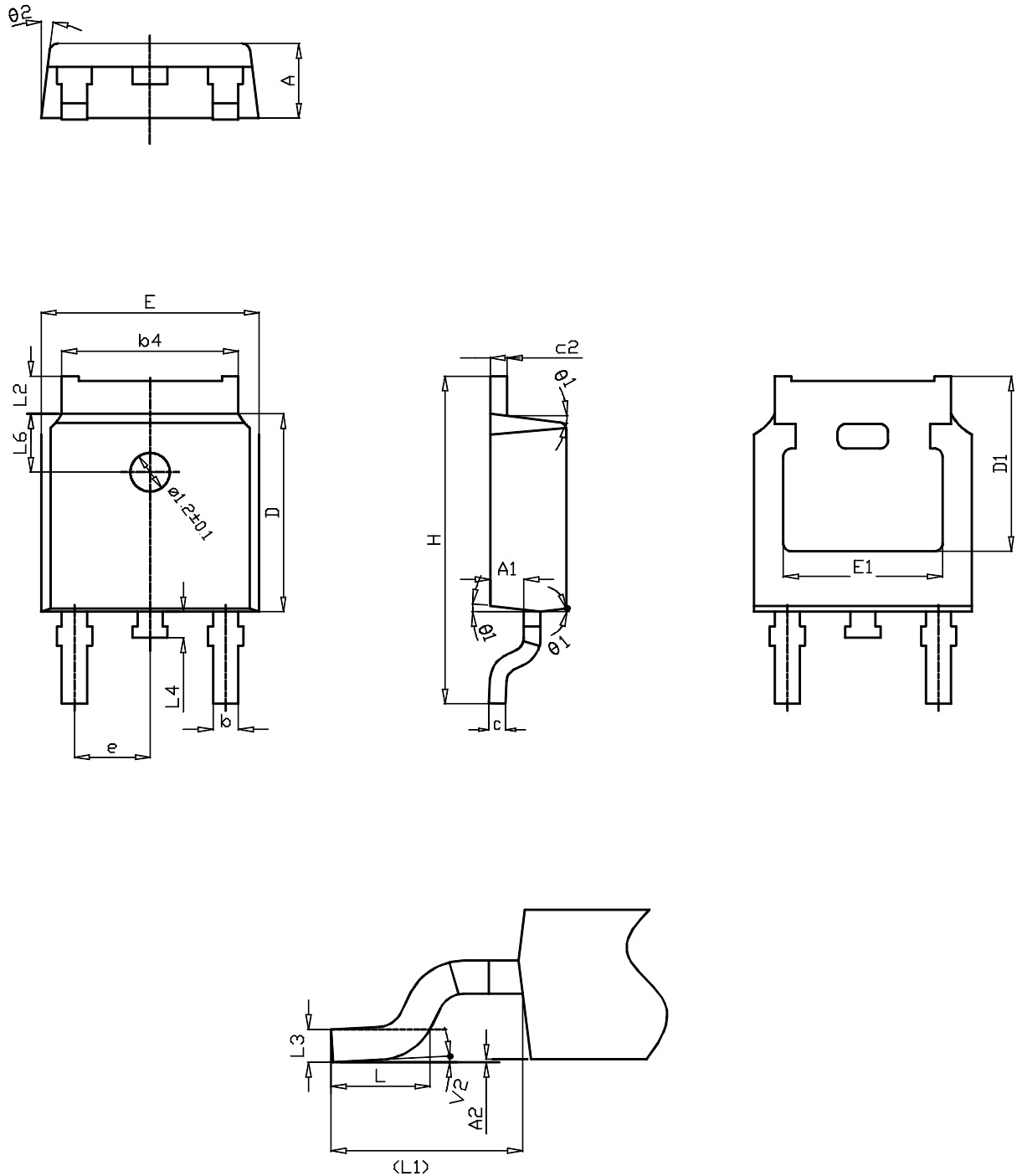

0068772\_C\_25

**Table 9. DPAK (TO-252) type C mechanical data**

Dim.	mm		
	Min.	Typ.	Max.
A	2.20	2.30	2.38
A1	0.90	1.01	1.10
A2	0.00		0.10
b	0.72		0.85
b4	5.13	5.33	5.46
c	0.47		0.60
c2	0.47		0.60
D	6.00	6.10	6.20
D1	5.25		
E	6.50	6.60	6.70
E1	4.70		
e	2.186	2.286	2.386
H	9.80	10.10	10.40
L	1.40	1.50	1.70
L1	2.90 REF		
L2	0.90		1.25
L3	0.51 BSC		
L4	0.60	0.80	1.00
L6	1.80 BSC		
θ1	5°	7°	9°
θ2	5°	7°	9°
V2	0°		8°

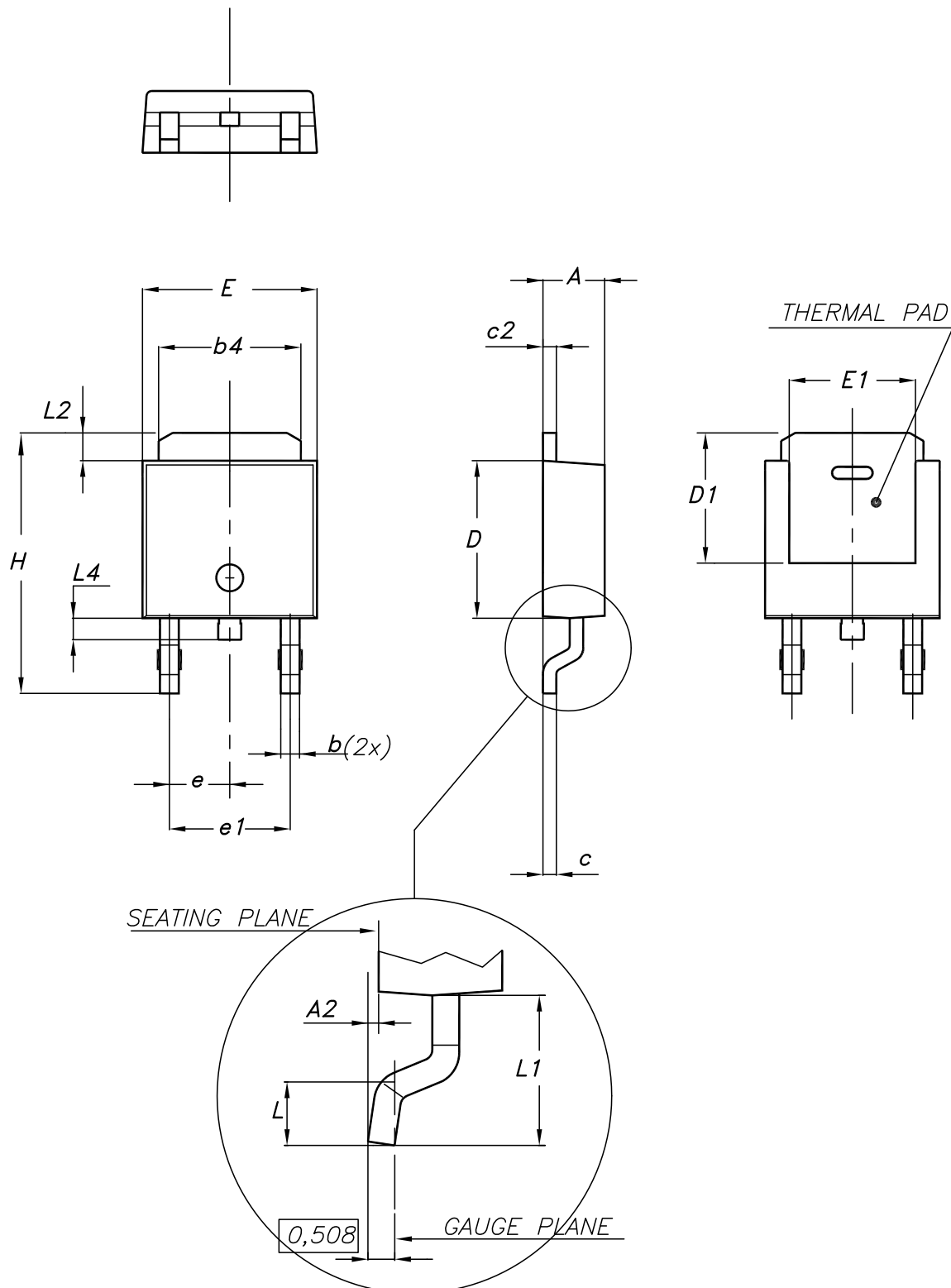
**4.3 DPAK (TO-252) type E package information**
**Figure 24. DPAK (TO-252) type E package outline**

**Table 10. DPAK (TO-252) type E mechanical data**

Dim.	mm		
	Min.	Typ.	Max.
A	2.18		2.39
A2			0.13
b	0.65		0.884
b4	4.95		5.46
c	0.46		0.61
c2	0.46		0.60
D	5.97		6.22
D1	5.21		
E	6.35		6.73
E1	4.32		
e		2.286	
e1		4.572	
H	9.94		10.34
L	1.50		1.78
L1		2.74	
L2	0.89		1.27
L4			1.02

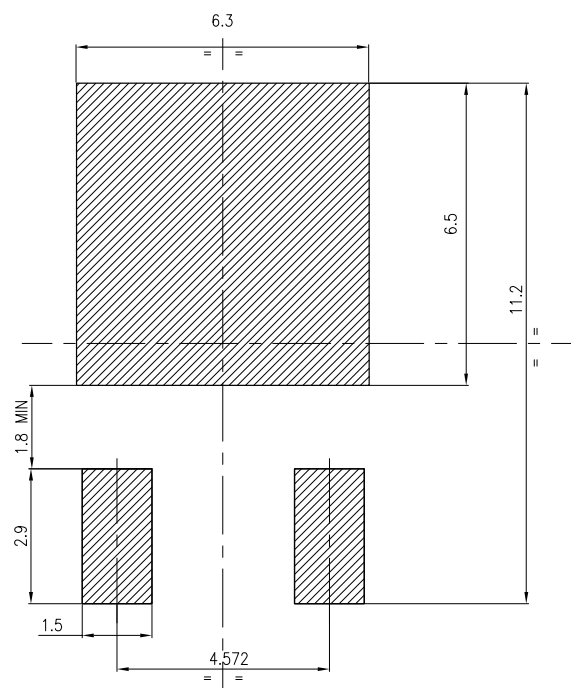
**Figure 25. DPAK (TO-252) recommended footprint (dimensions are in mm)**

FP\_0068772\_25

### 4.4 DPAK (TO-252) packing information

Figure 26. DPAK (TO-252) tape outline

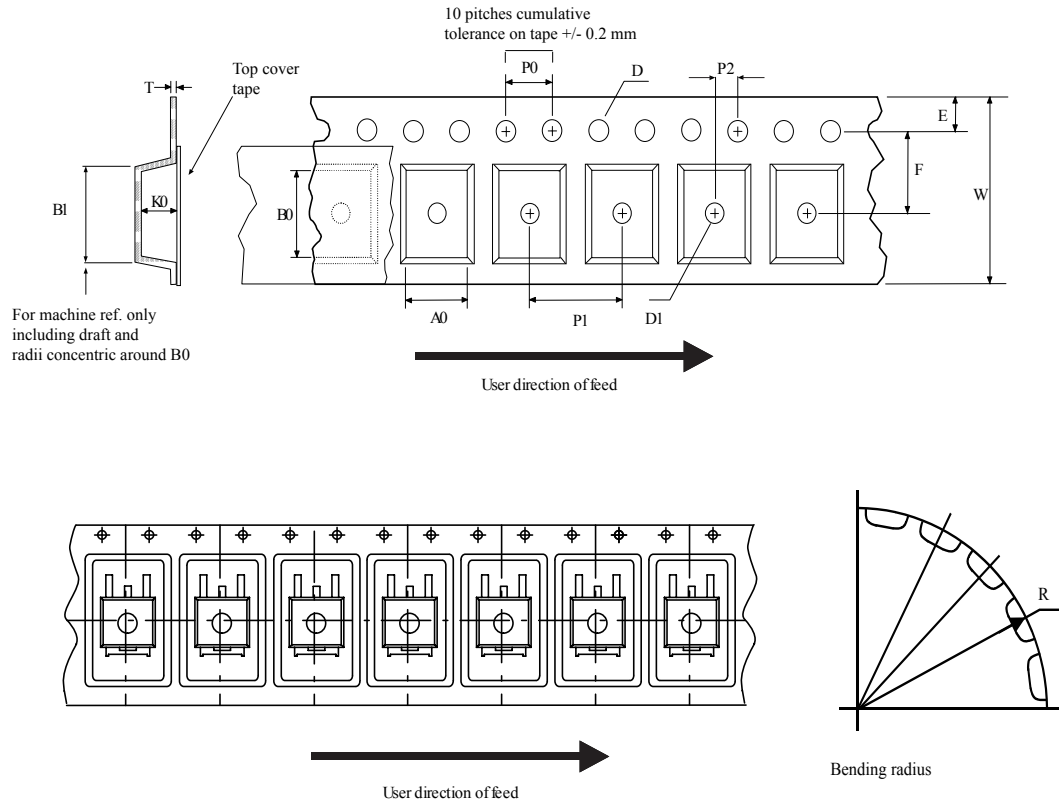

AM08852v1

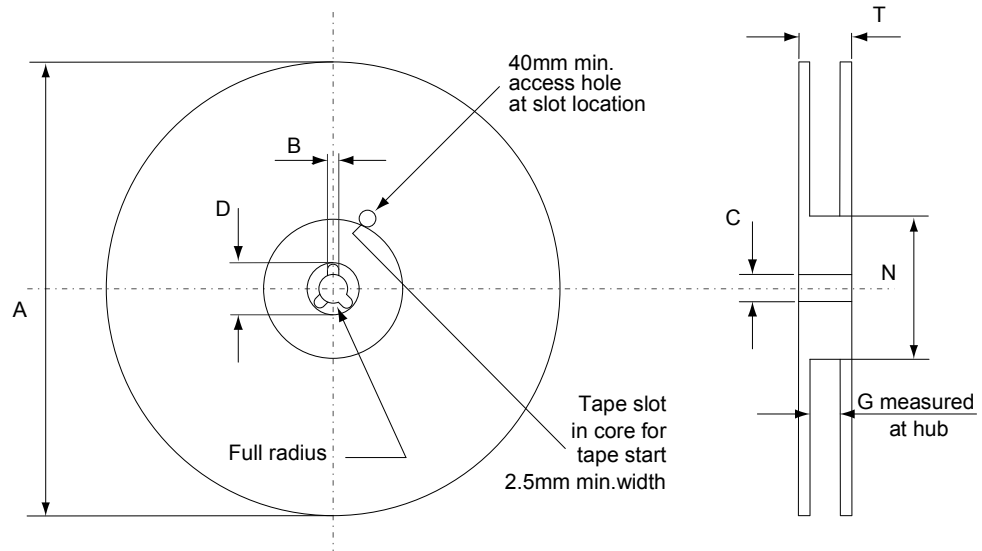
**Figure 27. DPAK (TO-252) reel outline**

AM06038v1

**Table 11. DPAK (TO-252) tape and reel mechanical data**

Tape			Reel		
Dim.	mm		Dim.	mm	
	Min.	Max.		Min.	Max.
A0	6.8	7	A		330
B0	10.4	10.6	B	1.5	
B1		12.1	C	12.8	13.2
D	1.5	1.6	D	20.2	
D1	1.5		G	16.4	18.4
E	1.65	1.85	N	50	
F	7.4	7.6	T		22.4
K0	2.55	2.75			
P0	3.9	4.1	Base qty.		2500
P1	7.9	8.1	Bulk qty.		2500
P2	1.9	2.1			
R	40				
T	0.25	0.35			
W	15.7	16.3			

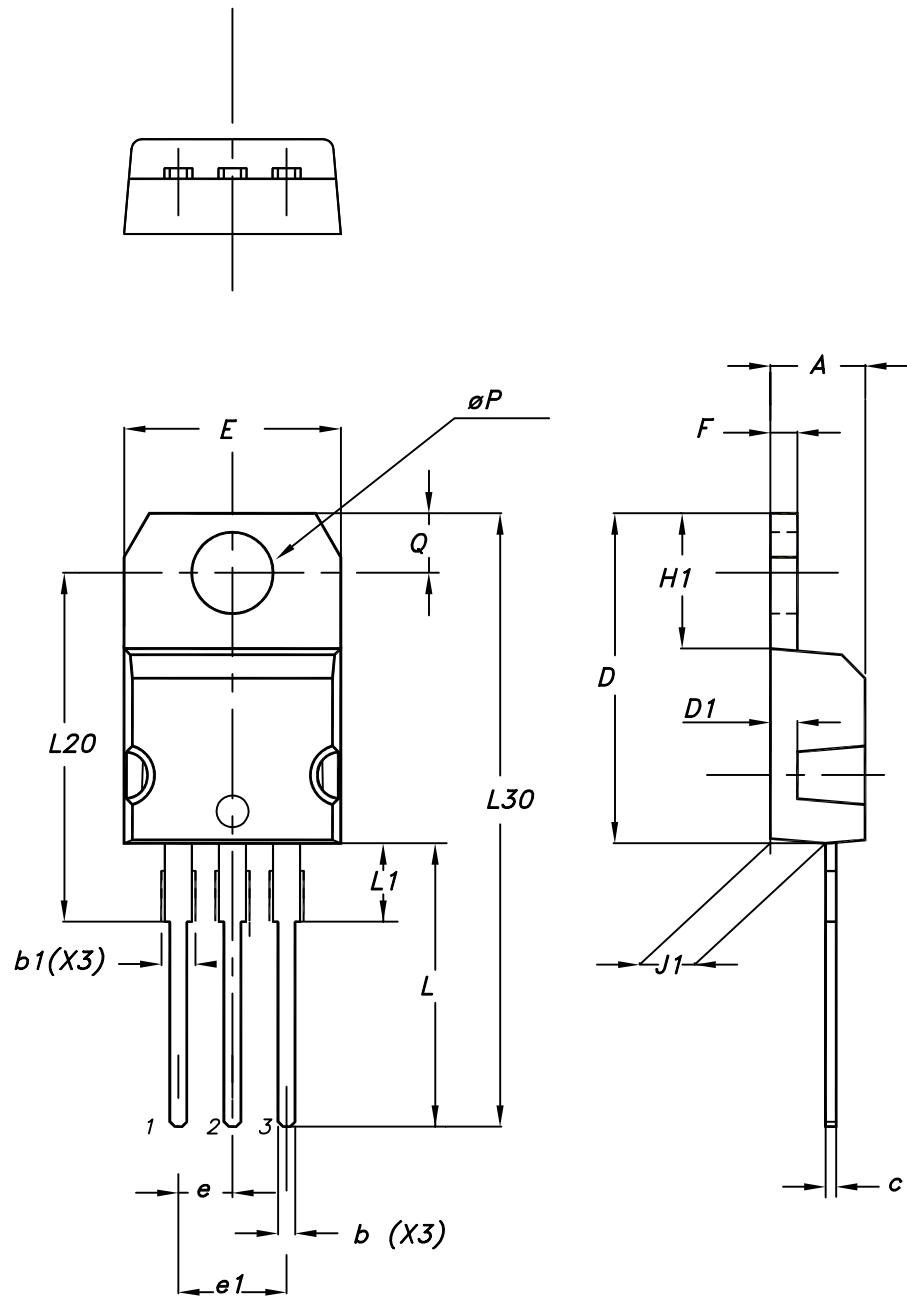
**4.5 TO-220 type A package information**
**Figure 28. TO-220 type A package outline**

0015988\_typeA\_Rev\_21

**Table 12. TO-220 type A package mechanical data**

Dim.	mm		
	Min.	Typ.	Max.
A	4.40		4.60
b	0.61		0.88
b1	1.14		1.55
c	0.48		0.70
D	15.25		15.75
D1		1.27	
E	10.00		10.40
e	2.40		2.70
e1	4.95		5.15
F	1.23		1.32
H1	6.20		6.60
J1	2.40		2.72
L	13.00		14.00
L1	3.50		3.93
L20		16.40	
L30		28.90	
øP	3.75		3.85
Q	2.65		2.95

#### 4.6 IPAK (TO-251) type A package information

Figure 29. IPAK (TO-251) type A package outline

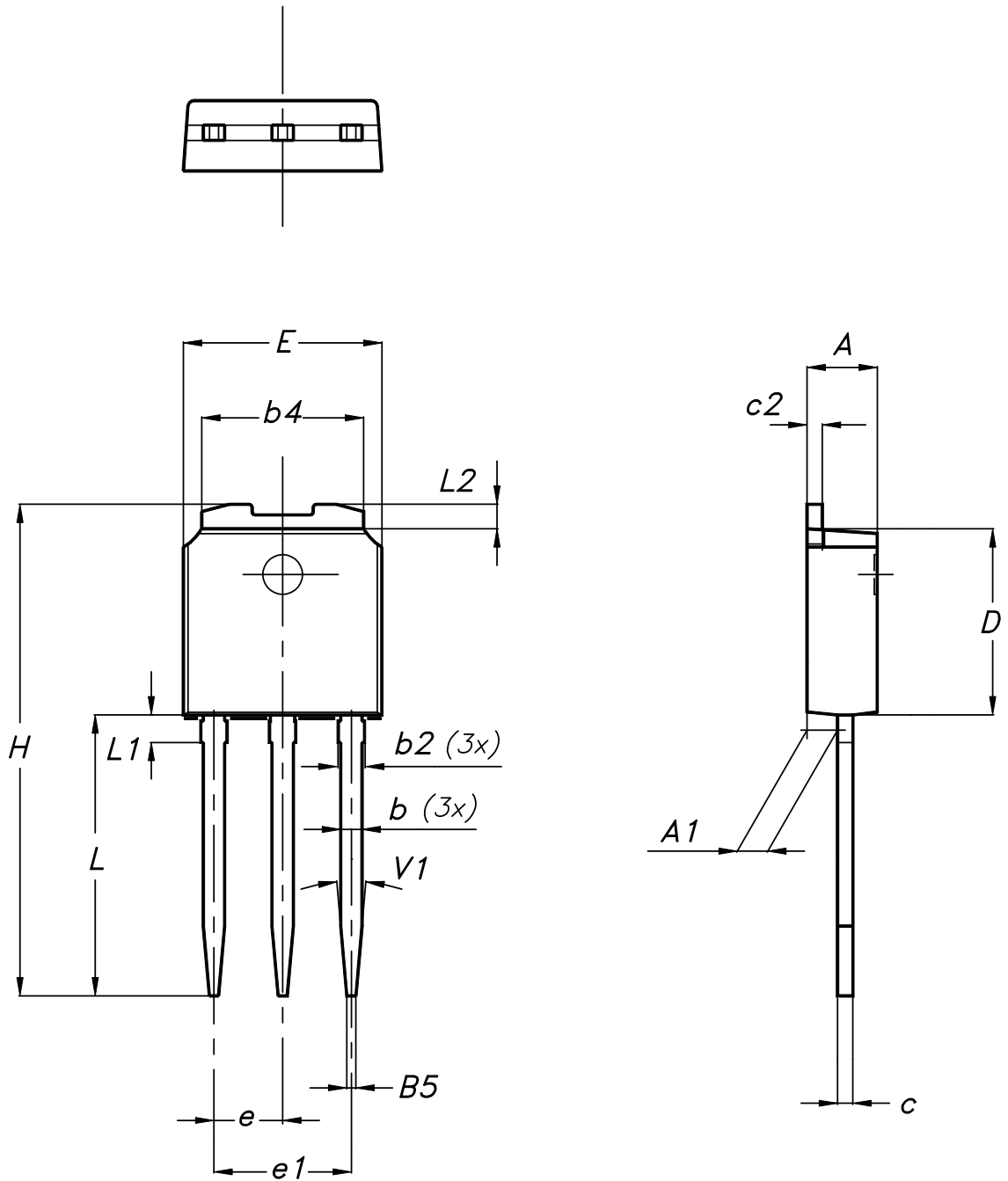

0068771\_IK\_typeA\_rev14

**Table 13. IPAK (TO-251) type A package mechanical data**

Dim.	mm		
	Min.	Typ.	Max.
A	2.20		2.40
A1	0.90		1.10
b	0.64		0.90
b2			0.95
b4	5.20		5.40
B5		0.30	
c	0.45		0.60
c2	0.48		0.60
D	6.00		6.20
E	6.40		6.60
e		2.28	
e1	4.40		4.60
H		16.10	
L	9.00		9.40
L1	0.80		1.20
L2		0.80	1.00
V1		10°	

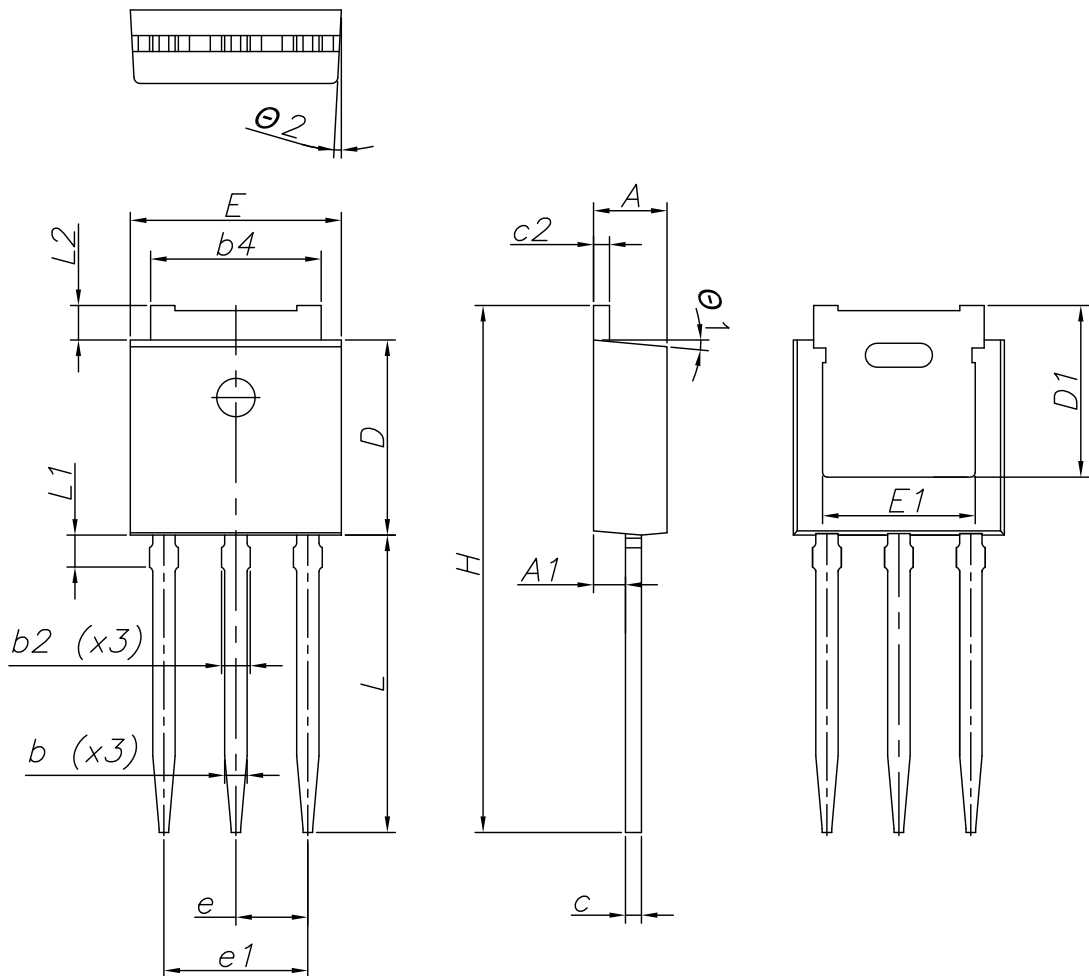
**4.7 IPAK (TO-251) type C package information**
**Figure 30. IPAK (TO-251) type C package outline**

0068771\_IK\_typeC\_rev14

**Table 14. IPAK (TO-251) type C package mechanical data**

Dim.	mm		
	Min.	Typ.	Max.
A	2.20	2.30	2.35
A1	0.90	1.00	1.10
b	0.66		0.79
b2			0.90
b4	5.23	5.33	5.43
c	0.46		0.59
c2	0.46		0.59
D	6.00	6.10	6.20
D1	5.20	5.37	5.55
E	6.50	6.60	6.70
E1	4.60	4.78	4.95
e	2.20	2.25	2.30
e1	4.40	4.50	4.60
H	16.18	16.48	16.78
L	9.00	9.30	9.60
L1	0.80	1.00	1.20
L2	0.90	1.08	1.25
θ1	3°	5°	7°
θ2	1°	3°	5°

## Revision history

**Table 15. Document revision history**

Date	Revision	Changes
06-Jun-2013	1	First release.
12-Jul-2018	2	Removed maturity status indication from cover page. The document status is production data. Added <a href="#">Section 4.2 DPAK (TO-252) type C package information</a> and <a href="#">Section 4.3 DPAK (TO-252) type E package information</a> . Minor text changes.

## Contents

<b>1</b>	<b>Electrical ratings</b> .....	<b>2</b>
<b>2</b>	<b>Electrical characteristics</b> .....	<b>3</b>
<b>2.1</b>	Electrical characteristics (curves) .....	5
<b>3</b>	<b>Test circuits</b> .....	<b>8</b>
<b>4</b>	<b>Package information</b> .....	<b>9</b>
<b>4.1</b>	DPAK (TO-252) type A package information .....	9
<b>4.2</b>	DPAK (TO-252) type C package information .....	11
<b>4.3</b>	DPAK (TO-252) type E package information .....	13
<b>4.4</b>	DPAK (TO-252) packing information .....	15
<b>4.5</b>	TO-220 type A package information .....	17
<b>4.6</b>	IPAK (TO-251) type A package information .....	19
<b>4.7</b>	IPAK (TO-251) type C package information .....	21
	<b>Revision history</b> .....	<b>24</b>

**IMPORTANT NOTICE – PLEASE READ CAREFULLY**

STMicroelectronics NV and its subsidiaries (“ST”) reserve the right to make changes, corrections, enhancements, modifications, and improvements to ST products and/or to this document at any time without notice. Purchasers should obtain the latest relevant information on ST products before placing orders. ST products are sold pursuant to ST’s terms and conditions of sale in place at the time of order acknowledgement.

Purchasers are solely responsible for the choice, selection, and use of ST products and ST assumes no liability for application assistance or the design of Purchasers’ products.

No license, express or implied, to any intellectual property right is granted by ST herein.

Resale of ST products with provisions different from the information set forth herein shall void any warranty granted by ST for such product.



ST and the ST logo are trademarks of ST. All other product or service names are the property of their respective owners.

Information in this document supersedes and replaces information previously supplied in any prior versions of this document.

© 2018 STMicroelectronics – All rights reserved

## Looking for pricing, stock, or lifecycle information?

Click below to explore more details on WIN SOURCE:

-  [View STP7N60M2 on WIN SOURCE](#)
-  [STMicroelectronics Information](#)

## Optimize Your Supply Chain with WIN SOURCE Solutions

-  Global Sourcing Solution
-  Obsolete Management
-  Cost Control Management
-  Shortage Management
-  Alternative Solution
-  Excess Inventory Management