



**THE DATASHEET OF
CD74HC4094PWR**



CDx4HC4094, CD74HCT4094 High-Speed CMOS Logic 8-Stage Shift and Store Bus Register, Three-State

1 Features

- Buffered inputs
- Separate serial outputs synchronous to both positive and negative clock edges for cascading
- Fanout (over temperature range)
 - Standard outputs: 10 LSTTL loads
 - Bus driver outputs: 15 LSTTL loads
- Wide operating temp range: -55°C to 125°C
- Balanced propagation delay and transition times
- Significant power reduction compared to LSTTL logic ICs
- HC types
 - 2- to 6-V operation
 - High noise immunity: $N_{IL} = 30\%$, $N_{IH} = 30\%$ of V_{CC} at $V_{CC} = 5\text{ V}$
- HCT types
 - 4.5- to 5.5-V operation
 - Direct LSTTL input logic compatibility, $V_{IL} = 0.8\text{ V}$ (Max), $V_{IH} = 2\text{ V}$ (Min)
 - CMOS input compatibility, $I_I \leq 1\mu\text{A}$ at V_{OL} , V_{OH}

2 Description

The CDx4HC4094 and CD74HCT4094 are 8-stage serial shift registers having a storage latch associated with each stage for strobing data from the serial input to parallel buffered tri-state outputs. The parallel outputs may be connected directly to common bus lines. Data is shifted on positive clock transitions. The data in each shift register stage is transferred to the storage register when the Strobe input is high. Data in the storage register appears at the outputs whenever the Output-Enable signal is high.

Device Information

PART NUMBER	PACKAGE ⁽¹⁾	BODY SIZE (NOM)
CD54HC4094F3A	CDIP (16)	24.38 mm × 6.92 mm
CD74HC4094M	SOIC (16)	9.90 mm × 3.90 mm
CD74HC4094E	PDIP (16)	19.31 mm × 6.35 mm
CD74HC4094NSR	SO (16)	6.20 mm × 5.30 mm
CD74HC4094PW	TSSOP (16)	5.00 mm × 4.40 mm
CD74HCT4094M	SOIC (16)	9.90 mm × 3.90 mm
CD74HCT4094E	PDIP (16)	19.31 mm × 6.35 mm

(1) For all available packages, see the orderable addendum at the end of the data sheet.

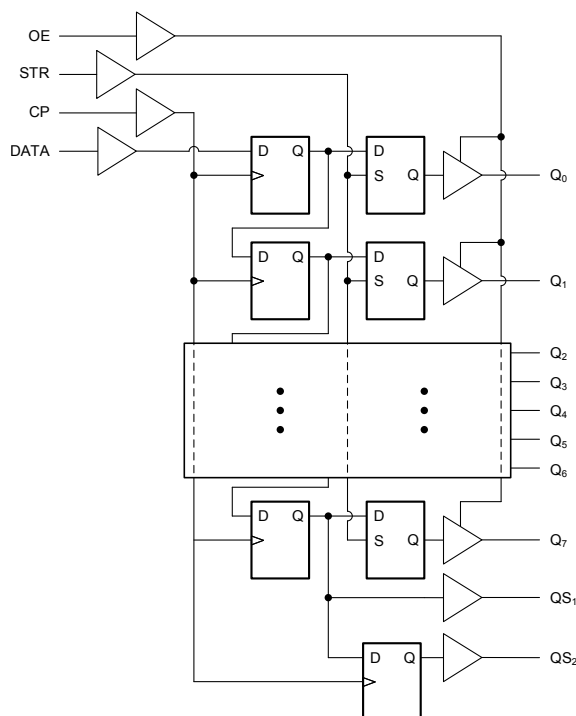

Functional Block Diagram



Table of Contents

1 Features	1	7.2 Functional Block Diagram.....	10
2 Description	1	7.3 Device Functional Modes.....	11
3 Revision History	2	8 Power Supply Recommendations	12
4 Pin Configuration and Functions	3	9 Layout	12
5 Specifications	4	9.1 Layout Guidelines.....	12
5.1 Absolute Maximum Ratings.....	4	10 Device and Documentation Support	13
5.2 Recommended Operating Conditions.....	4	10.1 Documentation Support.....	13
5.3 Thermal Information.....	4	10.2 Receiving Notification of Documentation Updates..	13
5.4 Electrical Characteristics.....	5	10.3 Support Resources.....	13
5.5 Prerequisite for Switching Characteristics.....	6	10.4 Trademarks.....	13
5.6 Switching Characteristics.....	7	10.5 Electrostatic Discharge Caution.....	13
6 Parameter Measurement Information	9	10.6 Glossary.....	13
7 Detailed Description	10	11 Mechanical, Packaging, and Orderable Information	13
7.1 Overview.....	10		

3 Revision History

Changes from Revision E (December 2010) to Revision F (March 2022)	Page
• Updated the numbering, formatting, tables, figures, and cross-references throughout the document to reflect modern data sheet standards.....	1

4 Pin Configuration and Functions

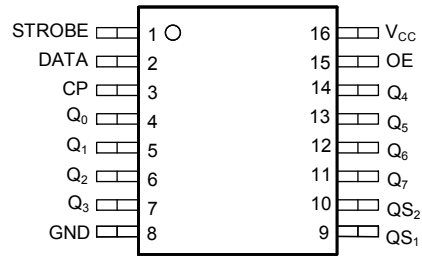

J, N, D, NS, or PW package
16-Pin CDIP, PDIP, SOIC, SO, or TSSOP
Top View

5 Specifications

5.1 Absolute Maximum Ratings

over operating free-air temperature range (unless otherwise noted) ⁽¹⁾

		MIN	MAX	UNIT
V _{CC}	Supply voltage	-0.5	7	V
I _{IK}	Input diode current	For V _I < -0.5 V or V _I > V _{CC} + 0.5 V		±20 mA
I _{OK}	Output diode current	For V _O < -0.5 V or V _O > V _{CC} + 0.5 V		±20 mA
I _O	Output source or sink current per output pin	For V _O > -0.5 V or V _O < V _{CC} + 0.5 V		±25 mA
	Continuous current through V _{CC} or GND			±50 mA
T _J	Junction temperature			150 °C
T _{stg}	Storage temperature	-65	150	°C
	Maximum lead temperature (Soldering 10s) (SOIC - lead tips only)			300 °C

- (1) Stresses beyond those listed under *Absolute Maximum Ratings* may cause permanent damage to the device. These are stress ratings only, which do not imply functional operation of the device at these or any other conditions beyond those indicated under *Recommended Operating Conditions*. Exposure to absolute-maximum-rated conditions for extended periods may affect device reliability.

5.2 Recommended Operating Conditions

over operating free-air temperature range (unless otherwise noted)

		MIN	NOM	MAX	UNIT
V _{CC}	Supply voltage range	HC types		6	V
		HCT types	4.5	5.5	
V _I , V _O	Input or output voltage	0		V _{CC}	V
t _t	Input rise and fall time	2 V		1000	ns
		4.5 V		500	
		6 V		400	
T _A	Temperature range	-55		125	°C

5.3 Thermal Information

THERMAL METRIC		N (PDIP)	D (SOIC) ⁽²⁾	NS (SOP)	PW (TSSOP)	UNIT
		PINS	PINS	PINS	PINS	
R _{θJA}	Junction-to-ambient thermal resistance ⁽¹⁾	67	73	64	108	°C/W

- (1) For more information about traditional and new thermal metrics, see the [Semiconductor and IC package thermal metrics](#) application report.
 (2) Lead tips only

5.4 Electrical Characteristics

over operating free-air temperature range (unless otherwise noted)

PARAMETER	TEST CONDITIONS ⁽²⁾	V _{CC} (V)	25°C			–40°C to 85°C		–55°C to 125°C		UNIT	
			MIN	TYP	MAX	MIN	MAX	MIN	MAX		
HC TYPES											
V _{IH}	High-level input voltage		2	1.5		1.5		1.5		V	
			4.5	3.15		3.15		3.15		V	
			6	4.2		4.2		4.2		V	
V _{IL}	Low-level input voltage		2		0.5		0.5		0.5	V	
			4.5		1.35		1.35		1.35	V	
			6		1.8		1.8		1.8	V	
V _{OH}	High-level output voltage CMOS loads	I _{OH} = –20μA	2	1.9		1.9		1.9		V	
		I _{OH} = –20μA	4.5	4.4		4.4		4.4		V	
		I _{OH} = –20μA	6	5.9		5.9		5.9		V	
	High-level output voltage TTL loads	I _{OH} = –6mA	4.5	3.98		3.84		3.7		V	
		I _{OH} = –7.8mA	6	5.48		5.34		5.2		V	
V _{OL}	Low-level output voltage CMOS loads	I _{OL} = 20μA	2		0.1		0.1		0.1	V	
		I _{OL} = 20μA	4.5		0.1		0.1		0.1	V	
		I _{OL} = 20μA	6		0.1		0.1		0.1	V	
	Low-level output voltage TTL loads	I _{OL} = 6mA	4.5		0.26		0.33		0.4	V	
		I _{OL} = 7.8mA	6		0.26		0.33		0.4	V	
I _I	Input leakage current	V _{CC} or GND	6		±0.1		±1		±1	μA	
I _{CC}	Supply current	V _{CC} or GND	6		8		80		160	μA	
HCT TYPES											
V _{IH}	High-level input voltage		4.5 to 5.5	2		2		2		V	
V _{IL}	Low-level input voltage		4.5 to 5.5		0.8		0.8		0.8	V	
V _{OH}	High-level output voltage CMOS loads	I _{OH} = –20μA	4.5	4.4		4.4		4.4		V	
	High-level output voltage TTL loads	I _{OH} = –6mA	4.5	3.98		3.84		3.7		V	
V _{OL}	Low-level output voltage CMOS loads	I _{OL} = 20μA	4.5		0.1		0.1		0.1	V	
	Low-level output voltage TTL loads	I _{OL} = 6mA	4.5		0.26		0.33		0.4	V	
I _I	Input leakage current	V _{CC} and GND	5.5		±0.1		±1		±1	μA	
I _{CC}	Supply Current	V _{CC} and GND	5.5		8		80		160	μA	
ΔI _{CC} ^{(1) (3)}	Additional quiescent device current per input pin: 1 unit load	D	4.5 to 5.5		40	144		180		196	μA
		CP, OE	4.5 to 5.5		150	540		675		735	μA
		STR	4.5 to 5.5		100	360		450		490	μA

(1) For dual-supply systems theoretical worst case (V_I = 2.4 V, V_{CC} = 5.5 V) specification is 1.8 mA.

(2) V_I = V_{IH} or V_{IL}, unless otherwise noted.

(3) Inputs held at V_{CC} – 2.1.

5.5 Prerequisite for Switching Characteristics

over operating free-air temperature range (unless otherwise noted)

PARAMETER		V _{CC} (V)	25°C		–40 to 85°C		–55 to 125°C		UNIT
			MIN	MAX	MIN	MAX	MIN	MAX	
HC TYPES									
t _W	CP pulse duration	2	80	100	120	ns			
		4.5	16	20	24				
		6	14	17	20				
t _{WH}	STR pulse duration	2	80	100	120	ns			
		4.5	16	20	24				
		6	14	17	20				
t _{SU}	Data set-up time	2	50	65	75	ns			
		4.5	10	13	15				
		6	9	11	13				
t _H	Data hold time	2	3	3	3	ns			
		4.5	3	3	3				
		6	3	3	3				
t _{SU}	STR set-up time	2	100	125	150	ns			
		4.5	20	25	30				
		6	17	21	26				
t _H	STR hold time	2	0	0	0	ns			
		4.5	0	0	0				
		6	0	0	0				
f _{CL (MAX)}	Maximum CP frequency	2	6	5	4	MHz			
		4.5	30	24	20				
		6	35	28	24				
HCT TYPES									
t _W	CP pulse duration	4.5	16	20	24	ns			
t _{WH}	STR pulse duration	4.5	16	20	24	ns			
t _{SU}	Data set-up time	4.5	10	13	15	ns			
t _H	Data hold time	4.5	4	4	4	ns			
t _{SU}	STR set-up time	4.5	20	25	30	ns			
t _H	STR hold time	4.5	0	0	0	ns			
f _{CL (MAX)}	Maximum CP frequency	4.5	30	24	20	MHz			

5.6 Switching Characteristics

Input t_r , t_f = 6 ns. Unless otherwise specified, C_L = 50pF [Parameter Measurement Information](#)

PARAMETER		V_{CC} (V)	25°C			-40 to 85°C		-55 to 125°C		UNIT
			MIN	TYP	MAX	MIN	MAX	MIN	MAX	
HC TYPES										
t_{pd}	Propagation delay time CP to QS_1	2		150		190		225	ns	
		4.5		12 ⁽³⁾	30		38	45		
		6		26		33		38		
t_{pd}	CP to QS_2	2		135		170		205	ns	
		4.5		11 ⁽³⁾	27		34	41		
		6		23		29		35		
t_{pd}	CP to Q_n	2		195		245		295	ns	
		4.5		16 ⁽³⁾	39		49	59		
		6		33		42		50		
t_t	STR to Q_n	2		180		225		270	ns	
		4.5		36		45		54		
		6		31		38		46		
t_{PZH} , t_{PZL}	Output enable to Q_n	2		175		220		265	ns	
		4.5		35		44		53		
		6		30		37		45		
t_{PHZ} , t_{PLZ}	Output disable to Q_n	2		125		155		190	ns	
		4.5		25		31		38		
		6		21		26		32		
t_{TLH} , t_{THL}	Output transition time	2		75		95		110	ns	
		4.5		15		19		22		
		6		13		16		19		
t_{PHZ} , t_{PLZ}	Output disabling time	5		10 ⁽³⁾					ns	
f_{MAX}	Maximum CP frequency	5		60 ⁽³⁾					MHz	
C_{IN}	Input capacitance			10		10		10	pF	
C_{PD}	Power dissipation capacitance ^{(1), (2)}	5		90 ⁽³⁾					pF	
C_O	Tri-state output capacitance			15		15		15	pF	
HCT TYPES										
t_{PLH} , t_{PHL}	Propagation delay time CP to QS_1	4.5		16 ⁽³⁾	39					ns
	CP to QS_2	4.5		15 ⁽³⁾	36					ns
	CP to Q_n	4.5		18 ⁽³⁾	43					ns
	STR to Q_n	4.5		39						ns
t_{PZH} , t_{PZL}	Output enable to Q_n	4.5		35						ns
t_{PHZ} , t_{PLZ}	Output disable to Q_n	4.5		35						ns
t_{TLH} , t_{THL}	Output transition time	4.5		15						ns
t_{PHZ} , t_{PLZ}	Output disabling time	5		14 ⁽³⁾						ns
f_{MAX}	Maximum CP frequency	5		60 ⁽³⁾						MHz
C_{IN}	Input capacitance			10		10		10		pF

Input t_r , t_f = 6 ns. Unless otherwise specified, C_L = 50pF [Parameter Measurement Information](#)

PARAMETER		V _{CC} (V)	25°C			-40 to 85°C		-55 to 125°C		UNIT
			MIN	TYP	MAX	MIN	MAX	MIN	MAX	
C _{PD}	Power dissipation capacitance ⁽¹⁾ , (2)	5	110 ⁽³⁾							pF
C _O	Tri-state output capacitance				15		15		15	pF

(1) C_{PD} is used to determine the dynamic power consumption, per register.

(2) $P_D = V_{CC}^2 f_i (C_{PD} + C_L)$ where f_i = Input frequency, C_L = Output load capacitance, V_{CC} = Supply voltage.

(3) Typical value tested at 5V, C_L = 15pF

6 Parameter Measurement Information

t_{PD} is the maximum between t_{PLH} and t_{PHL}

t_t is the maximum between t_{TLH} and t_{THL}

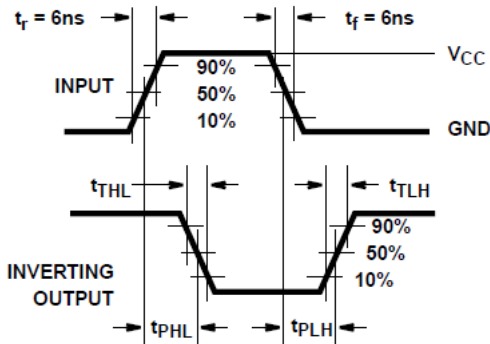

Figure 6-1. HC and HCT transition times and propagation delay times, combination logic

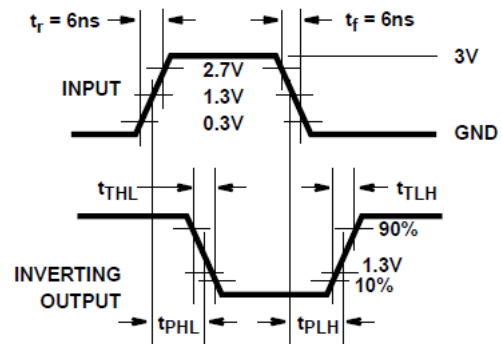

Figure 6-2. HCT transition times and propagation delay times, combination logic

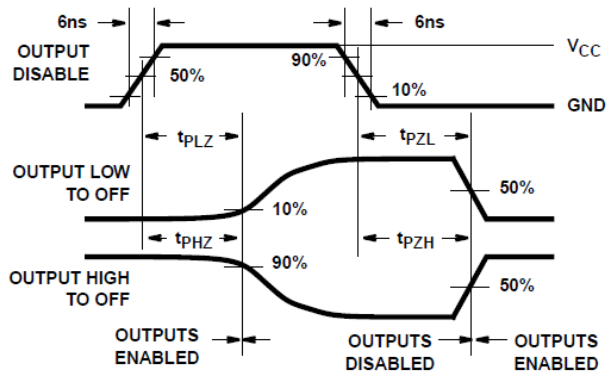

Figure 6-3. HC three-state propagation delay waveform

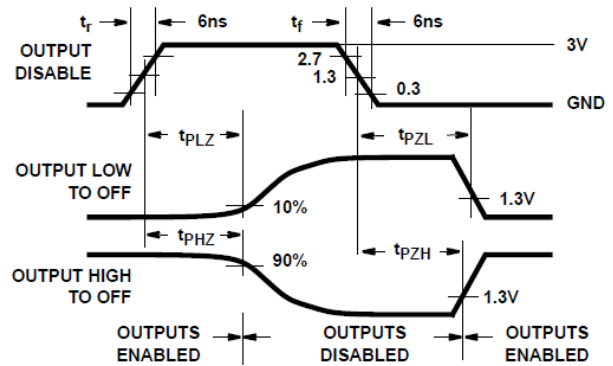
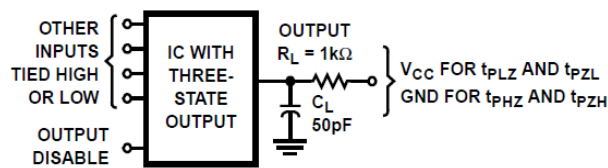

Figure 6-4. HCT three-state propagation delay waveform



NOTE: Open drain waveforms t_{PLZ} and t_{PZL} are the same as those for three-state shown on the left. The test circuit is Output $R_L = 1k\Omega$ to V_{CC} , $C_L = 50pF$.

Figure 6-5. HC and HCT three-state propagation delay test circuit

7 Detailed Description

7.1 Overview

The CDx4HC4094 and CD74HCT4094 are 8-stage serial shift registers having a storage latch associated with each stage for strobing data from the serial input to parallel buffered tri-state outputs. The parallel outputs may be connected directly to common bus lines. Data is shifted on positive clock transitions. The data in each shift register stage is transferred to the storage register when the Strobe input is high. Data in the storage register appears at the outputs whenever the Output-Enable signal is high.

Two serial outputs are available for cascading a number of these devices. Data is available at the QS₁ serial output terminal on positive clock edges to allow for high-speed operation in cascaded system in which the clock rise time is fast. The same serial information, available at the QS₂ terminal on the next negative clock edge, provides a means for cascading these devices when the clock rise time is slow.

7.2 Functional Block Diagram

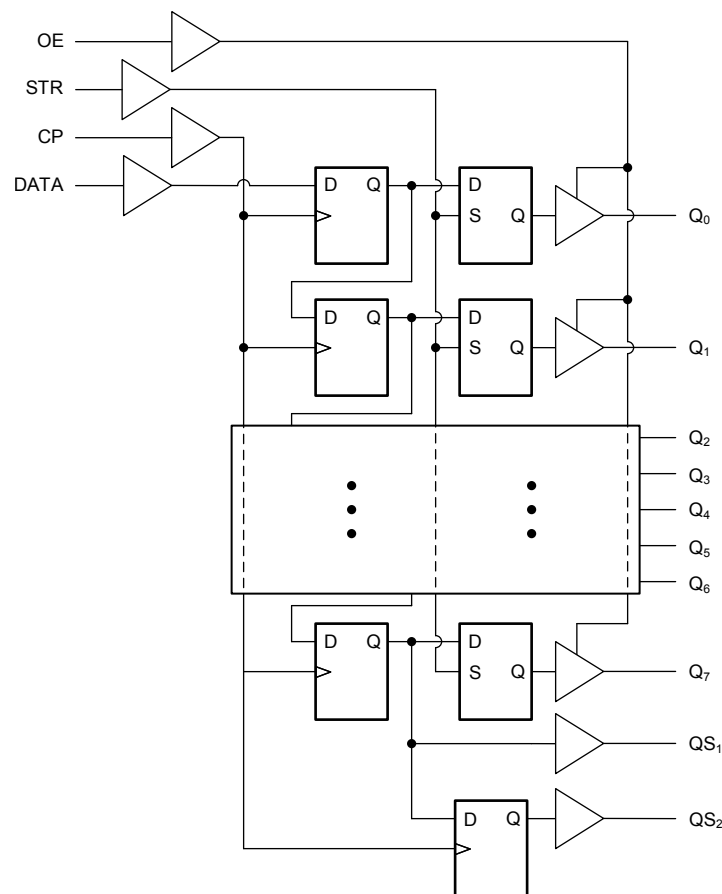

7.3 Device Functional Modes

Table 7-1. Truth Table

Inputs ⁽²⁾				Parallel Outputs		Serial Outputs	
CP	OE	STR	D	Q ₀	Q _n	QS ₁ ⁽¹⁾	QS ₂
↑	L	X	X	Z	Z	Q ₆	NC
↓	L	X	X	Z	Z	NC	Q ₇
↑	H	L	X	NC	NC	Q ₆	NC
↑	H	H	L	L	Q _n – 1	Q ₆	NC
↑	H	H	H	H	Q _n – 1	Q ₆	NC
↓	H	H	H	NC	NC	NC	Q ₇

- (1) At the positive clock edge the information in the seventh register stage is transferred to the eighth register stage and QS₁ output.
- (2) H = High voltage level, L = Low voltage level, X = Don't care, NC = No charge, Z = High-impedance off-state, ↑ = Transition from low-to-high level, ↓ = Transition from high to low.

8 Power Supply Recommendations

The power supply can be any voltage between the minimum and maximum supply voltage rating located in the *Recommended Operating Conditions*. Each V_{CC} terminal should have a good bypass capacitor to prevent power disturbance. A 0.1- μ F capacitor is recommended for this device. It is acceptable to parallel multiple bypass caps to reject different frequencies of noise. The 0.1- μ F and 1- μ F capacitors are commonly used in parallel. The bypass capacitor should be installed as close to the power terminal as possible for best results.

9 Layout

9.1 Layout Guidelines

When using multiple-input and multiple-channel logic devices inputs must not ever be left floating. In many cases, functions or parts of functions of digital logic devices are unused; for example, when only two inputs of a triple-input AND gate are used or only 3 of the 4 buffer gates are used. Such unused input pins must not be left unconnected because the undefined voltages at the outside connections result in undefined operational states. All unused inputs of digital logic devices must be connected to a logic high or logic low voltage, as defined by the input voltage specifications, to prevent them from floating. The logic level that must be applied to any particular unused input depends on the function of the device. Generally, the inputs are tied to GND or V_{CC} , whichever makes more sense for the logic function or is more convenient.

10 Device and Documentation Support

TI offers an extensive line of development tools. Tools and software to evaluate the performance of the device, generate code, and develop solutions are listed below.

10.1 Documentation Support

10.1.1 Related Documentation

10.2 Receiving Notification of Documentation Updates

To receive notification of documentation updates, navigate to the device product folder on ti.com. Click on *Subscribe to updates* to register and receive a weekly digest of any product information that has changed. For change details, review the revision history included in any revised document.

10.3 Support Resources

[TI E2E™ support forums](#) are an engineer's go-to source for fast, verified answers and design help — straight from the experts. Search existing answers or ask your own question to get the quick design help you need.

Linked content is provided "AS IS" by the respective contributors. They do not constitute TI specifications and do not necessarily reflect TI's views; see TI's [Terms of Use](#).

10.4 Trademarks

TI E2E™ is a trademark of Texas Instruments.
All trademarks are the property of their respective owners.

10.5 Electrostatic Discharge Caution



This integrated circuit can be damaged by ESD. Texas Instruments recommends that all integrated circuits be handled with appropriate precautions. Failure to observe proper handling and installation procedures can cause damage.

ESD damage can range from subtle performance degradation to complete device failure. Precision integrated circuits may be more susceptible to damage because very small parametric changes could cause the device not to meet its published specifications.

10.6 Glossary

[TI Glossary](#) This glossary lists and explains terms, acronyms, and definitions.

11 Mechanical, Packaging, and Orderable Information

The following pages include mechanical, packaging, and orderable information. This information is the most current data available for the designated devices. This data is subject to change without notice and revision of this document. For browser-based versions of this data sheet, refer to the left-hand navigation.

PACKAGING INFORMATION

Orderable Device	Status (1)	Package Type	Package Drawing	Pins	Package Qty	Eco Plan (2)	Lead finish/ Ball material (6)	MSL Peak Temp (3)	Op Temp (°C)	Device Marking (4/5)	Samples
CD54HC4094F3A	ACTIVE	CDIP	J	16	25	Non-RoHS & Green	SNPB	N / A for Pkg Type	-55 to 125	CD54HC4094F3A	Samples
CD74HC4094E	ACTIVE	PDIP	N	16	25	RoHS & Green	NIPDAU	N / A for Pkg Type	-55 to 125	CD74HC4094E	Samples
CD74HC4094M96	ACTIVE	SOIC	D	16	2500	RoHS & Green	NIPDAU SN	Level-1-260C-UNLIM	-55 to 125	HC4094M	Samples
CD74HC4094M96G3	ACTIVE	SOIC	D	16	2500	RoHS & Green	SN	Level-1-260C-UNLIM	-55 to 125	HC4094M	Samples
CD74HC4094M96G4	ACTIVE	SOIC	D	16	2500	RoHS & Green	NIPDAU	Level-1-260C-UNLIM	-55 to 125	HC4094M	Samples
CD74HC4094NSR	ACTIVE	SO	NS	16	2000	RoHS & Green	NIPDAU	Level-1-260C-UNLIM	-55 to 125	HC4094M	Samples
CD74HC4094NSRE4	ACTIVE	SO	NS	16	2000	RoHS & Green	NIPDAU	Level-1-260C-UNLIM	-55 to 125	HC4094M	Samples
CD74HC4094PWR	ACTIVE	TSSOP	PW	16	2000	RoHS & Green	NIPDAU SN	Level-1-260C-UNLIM	-55 to 125	HJ4094	Samples
CD74HC4094PWRE4	ACTIVE	TSSOP	PW	16	2000	RoHS & Green	NIPDAU	Level-1-260C-UNLIM	-55 to 125	HJ4094	Samples
CD74HC4094PWRG4	ACTIVE	TSSOP	PW	16	2000	RoHS & Green	NIPDAU	Level-1-260C-UNLIM	-55 to 125	HJ4094	Samples
CD74HCT4094E	ACTIVE	PDIP	N	16	25	RoHS & Green	NIPDAU	N / A for Pkg Type	-55 to 125	CD74HCT4094E	Samples
CD74HCT4094EE4	ACTIVE	PDIP	N	16	25	RoHS & Green	NIPDAU	N / A for Pkg Type	-55 to 125	CD74HCT4094E	Samples
CD74HCT4094M96	ACTIVE	SOIC	D	16	2500	RoHS & Green	NIPDAU SN	Level-1-260C-UNLIM	-55 to 125	HCT4094M	Samples

(1) The marketing status values are defined as follows:

ACTIVE: Product device recommended for new designs.

LIFEBUY: TI has announced that the device will be discontinued, and a lifetime-buy period is in effect.

NRND: Not recommended for new designs. Device is in production to support existing customers, but TI does not recommend using this part in a new design.

PREVIEW: Device has been announced but is not in production. Samples may or may not be available.

OBSOLETE: TI has discontinued the production of the device.

(2) **RoHS:** TI defines "RoHS" to mean semiconductor products that are compliant with the current EU RoHS requirements for all 10 RoHS substances, including the requirement that RoHS substance do not exceed 0.1% by weight in homogeneous materials. Where designed to be soldered at high temperatures, "RoHS" products are suitable for use in specified lead-free processes. TI may reference these types of products as "Pb-Free".

RoHS Exempt: TI defines "RoHS Exempt" to mean products that contain lead but are compliant with EU RoHS pursuant to a specific EU RoHS exemption.

Green: TI defines "Green" to mean the content of Chlorine (Cl) and Bromine (Br) based flame retardants meet JS709B low halogen requirements of ≤ 1000 ppm threshold. Antimony trioxide based flame retardants must also meet the ≤ 1000 ppm threshold requirement.

- (3) MSL, Peak Temp. - The Moisture Sensitivity Level rating according to the JEDEC industry standard classifications, and peak solder temperature.
- (4) There may be additional marking, which relates to the logo, the lot trace code information, or the environmental category on the device.
- (5) Multiple Device Markings will be inside parentheses. Only one Device Marking contained in parentheses and separated by a "~" will appear on a device. If a line is indented then it is a continuation of the previous line and the two combined represent the entire Device Marking for that device.
- (6) Lead finish/Ball material - Orderable Devices may have multiple material finish options. Finish options are separated by a vertical ruled line. Lead finish/Ball material values may wrap to two lines if the finish value exceeds the maximum column width.

Important Information and Disclaimer: The information provided on this page represents TI's knowledge and belief as of the date that it is provided. TI bases its knowledge and belief on information provided by third parties, and makes no representation or warranty as to the accuracy of such information. Efforts are underway to better integrate information from third parties. TI has taken and continues to take reasonable steps to provide representative and accurate information but may not have conducted destructive testing or chemical analysis on incoming materials and chemicals. TI and TI suppliers consider certain information to be proprietary, and thus CAS numbers and other limited information may not be available for release.

In no event shall TI's liability arising out of such information exceed the total purchase price of the TI part(s) at issue in this document sold by TI to Customer on an annual basis.

OTHER QUALIFIED VERSIONS OF CD54HC4094, CD74HC4094 :

- Catalog : [CD74HC4094](#)
- Military : [CD54HC4094](#)

NOTE: Qualified Version Definitions:

- Catalog - TI's standard catalog product
- Military - QML certified for Military and Defense Applications

TAPE AND REEL INFORMATION

QUADRANT ASSIGNMENTS FOR PIN 1 ORIENTATION IN TAPE



*All dimensions are nominal

Device	Package Type	Package Drawing	Pins	SPQ	Reel Diameter (mm)	Reel Width W1 (mm)	A0 (mm)	B0 (mm)	K0 (mm)	P1 (mm)	W (mm)	Pin1 Quadrant
CD74HC4094M96	SOIC	D	16	2500	330.0	16.4	6.5	10.3	2.1	8.0	16.0	Q1
CD74HC4094M96G3	SOIC	D	16	2500	330.0	16.8	6.5	10.3	2.1	8.0	16.0	Q1
CD74HC4094M96G4	SOIC	D	16	2500	330.0	16.4	6.5	10.3	2.1	8.0	16.0	Q1
CD74HC4094NSR	SO	NS	16	2000	330.0	16.4	8.2	10.5	2.5	12.0	16.0	Q1
CD74HC4094NSR	SO	NS	16	2000	330.0	16.4	8.45	10.55	2.5	12.0	16.2	Q1
CD74HC4094PWR	TSSOP	PW	16	2000	330.0	12.4	6.9	5.6	1.6	8.0	12.0	Q1
CD74HC4094PWR	TSSOP	PW	16	2000	330.0	12.4	6.9	5.6	1.6	8.0	12.0	Q1
CD74HC4094PWRG4	TSSOP	PW	16	2000	330.0	12.4	6.9	5.6	1.6	8.0	12.0	Q1
CD74HCT4094M96	SOIC	D	16	2500	330.0	16.4	6.5	10.3	2.1	8.0	16.0	Q1

TAPE AND REEL BOX DIMENSIONS

*All dimensions are nominal

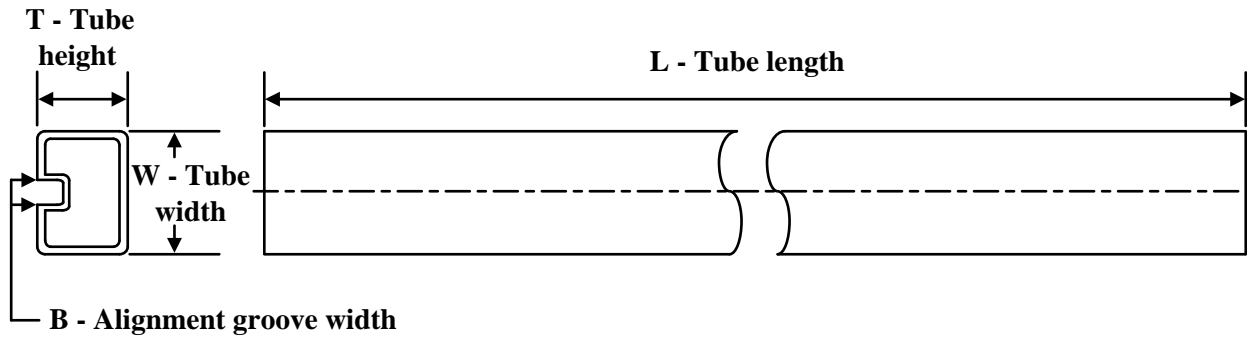
Device	Package Type	Package Drawing	Pins	SPQ	Length (mm)	Width (mm)	Height (mm)
CD74HC4094M96	SOIC	D	16	2500	356.0	356.0	35.0
CD74HC4094M96G3	SOIC	D	16	2500	364.0	364.0	27.0
CD74HC4094M96G4	SOIC	D	16	2500	340.5	336.1	32.0
CD74HC4094NSR	SO	NS	16	2000	356.0	356.0	35.0
CD74HC4094NSR	SO	NS	16	2000	356.0	356.0	35.0
CD74HC4094PWR	TSSOP	PW	16	2000	356.0	356.0	35.0
CD74HC4094PWR	TSSOP	PW	16	2000	356.0	356.0	35.0
CD74HC4094PWRG4	TSSOP	PW	16	2000	356.0	356.0	35.0
CD74HCT4094M96	SOIC	D	16	2500	356.0	356.0	35.0

TUBE

*All dimensions are nominal

Device	Package Name	Package Type	Pins	SPQ	L (mm)	W (mm)	T (μm)	B (mm)
CD74HC4094E	N	PDIP	16	25	506	13.97	11230	4.32
CD74HC4094E	N	PDIP	16	25	506	13.97	11230	4.32
CD74HCT4094E	N	PDIP	16	25	506	13.97	11230	4.32
CD74HCT4094E	N	PDIP	16	25	506	13.97	11230	4.32
CD74HCT4094EE4	N	PDIP	16	25	506	13.97	11230	4.32
CD74HCT4094EE4	N	PDIP	16	25	506	13.97	11230	4.32

D (R-PDSO-G16)

PLASTIC SMALL OUTLINE



- NOTES:
- A. All linear dimensions are in inches (millimeters).
 - B. This drawing is subject to change without notice.
 - C. Body length does not include mold flash, protrusions, or gate burrs. Mold flash, protrusions, or gate burrs shall not exceed 0.006 (0,15) each side.
 - D. Body width does not include interlead flash. Interlead flash shall not exceed 0.017 (0,43) each side.
 - E. Reference JEDEC MS-012 variation AC.

D (R-PDSO-G16)

PLASTIC SMALL OUTLINE



- NOTES:
- All linear dimensions are in millimeters.
 - This drawing is subject to change without notice.
 - Publication IPC-7351 is recommended for alternate designs.
 - Laser cutting apertures with trapezoidal walls and also rounding corners will offer better paste release. Customers should contact their board assembly site for stencil design recommendations. Refer to IPC-7525 for other stencil recommendations.
 - Customers should contact their board fabrication site for solder mask tolerances between and around signal pads.



4220204/A 02/2017

NOTES:

1. All linear dimensions are in millimeters. Any dimensions in parenthesis are for reference only. Dimensioning and tolerancing per ASME Y14.5M.
2. This drawing is subject to change without notice.
3. This dimension does not include mold flash, protrusions, or gate burrs. Mold flash, protrusions, or gate burrs shall not exceed 0.15 mm per side.
4. This dimension does not include interlead flash. Interlead flash shall not exceed 0.25 mm per side.
5. Reference JEDEC registration MO-153.

EXAMPLE BOARD LAYOUT

PW0016A

TSSOP - 1.2 mm max height

SMALL OUTLINE PACKAGE



LAND PATTERN EXAMPLE
EXPOSED METAL SHOWN
SCALE: 10X



4220204/A 02/2017

NOTES: (continued)

- 6. Publication IPC-7351 may have alternate designs.
- 7. Solder mask tolerances between and around signal pads can vary based on board fabrication site.

EXAMPLE STENCIL DESIGN

PW0016A

TSSOP - 1.2 mm max height

SMALL OUTLINE PACKAGE



SOLDER PASTE EXAMPLE
BASED ON 0.125 mm THICK STENCIL
SCALE: 10X

4220204/A 02/2017

NOTES: (continued)

8. Laser cutting apertures with trapezoidal walls and rounded corners may offer better paste release. IPC-7525 may have alternate design recommendations.
9. Board assembly site may have different recommendations for stencil design.

MECHANICAL DATA

NS (R-PDSO-G**)

PLASTIC SMALL-OUTLINE PACKAGE

14-PINS SHOWN



- NOTES:
- A. All linear dimensions are in millimeters.
 - B. This drawing is subject to change without notice.
 - C. Body dimensions do not include mold flash or protrusion, not to exceed 0,15.

J (R-GDIP-T**)

14 LEADS SHOWN

CERAMIC DUAL IN-LINE PACKAGE



DIM \ PINS **	14	16	18	20
A	0.300 (7,62) BSC	0.300 (7,62) BSC	0.300 (7,62) BSC	0.300 (7,62) BSC
B MAX	0.785 (19,94)	.840 (21,34)	0.960 (24,38)	1.060 (26,92)
B MIN	—	—	—	—
C MAX	0.300 (7,62)	0.300 (7,62)	0.310 (7,87)	0.300 (7,62)
C MIN	0.245 (6,22)	0.245 (6,22)	0.220 (5,59)	0.245 (6,22)



4040083/F 03/03

- NOTES:
- All linear dimensions are in inches (millimeters).
 - This drawing is subject to change without notice.
 - This package is hermetically sealed with a ceramic lid using glass frit.
 - Index point is provided on cap for terminal identification only on press ceramic glass frit seal only.
 - Falls within MIL STD 1835 GDIP1-T14, GDIP1-T16, GDIP1-T18 and GDIP1-T20.

N (R-PDIP-T**)

PLASTIC DUAL-IN-LINE PACKAGE

16 PINS SHOWN



- NOTES:
- A. All linear dimensions are in inches (millimeters).
 - B. This drawing is subject to change without notice.
 - C. Falls within JEDEC MS-001, except 18 and 20 pin minimum body length (Dim A).
 - D. The 20 pin end lead shoulder width is a vendor option, either half or full width.



PACKAGE OUTLINE

NS0016A

SOP - 2.00 mm max height

SOP



4220735/A 12/2021

NOTES:

1. All linear dimensions are in millimeters. Dimensions in parenthesis are for reference only. Dimensioning and tolerancing per ASME Y14.5M.
2. This drawing is subject to change without notice.
3. This dimension does not include mold flash, protrusions, or gate burrs. Mold flash, protrusions, or gate burrs shall not exceed 0.15 mm, per side.
4. This dimension does not include interlead flash. Interlead flash shall not exceed 0.25 mm, per side.

EXAMPLE BOARD LAYOUT

NS0016A

SOP - 2.00 mm max height

SOP



4220735/A 12/2021

NOTES: (continued)

5. Publication IPC-7351 may have alternate designs.

6. Solder mask tolerances between and around signal pads can vary based on board fabrication site.

EXAMPLE STENCIL DESIGN

NS0016A

SOP - 2.00 mm max height

SOP



SOLDER PASTE EXAMPLE
BASED ON 0.125 mm THICK STENCIL
SCALE:7X

4220735/A 12/2021

NOTES: (continued)

7. Laser cutting apertures with trapezoidal walls and rounded corners may offer better paste release. IPC-7525 may have alternate design recommendations.
8. Board assembly site may have different recommendations for stencil design.

IMPORTANT NOTICE AND DISCLAIMER

TI PROVIDES TECHNICAL AND RELIABILITY DATA (INCLUDING DATA SHEETS), DESIGN RESOURCES (INCLUDING REFERENCE DESIGNS), APPLICATION OR OTHER DESIGN ADVICE, WEB TOOLS, SAFETY INFORMATION, AND OTHER RESOURCES "AS IS" AND WITH ALL FAULTS, AND DISCLAIMS ALL WARRANTIES, EXPRESS AND IMPLIED, INCLUDING WITHOUT LIMITATION ANY IMPLIED WARRANTIES OF MERCHANTABILITY, FITNESS FOR A PARTICULAR PURPOSE OR NON-INFRINGEMENT OF THIRD PARTY INTELLECTUAL PROPERTY RIGHTS.

These resources are intended for skilled developers designing with TI products. You are solely responsible for (1) selecting the appropriate TI products for your application, (2) designing, validating and testing your application, and (3) ensuring your application meets applicable standards, and any other safety, security, regulatory or other requirements.

These resources are subject to change without notice. TI grants you permission to use these resources only for development of an application that uses the TI products described in the resource. Other reproduction and display of these resources is prohibited. No license is granted to any other TI intellectual property right or to any third party intellectual property right. TI disclaims responsibility for, and you will fully indemnify TI and its representatives against, any claims, damages, costs, losses, and liabilities arising out of your use of these resources.

TI's products are provided subject to [TI's Terms of Sale](#) or other applicable terms available either on [ti.com](https://www.ti.com) or provided in conjunction with such TI products. TI's provision of these resources does not expand or otherwise alter TI's applicable warranties or warranty disclaimers for TI products.

TI objects to and rejects any additional or different terms you may have proposed.

Mailing Address: Texas Instruments, Post Office Box 655303, Dallas, Texas 75265
Copyright © 2024, Texas Instruments Incorporated

Looking for pricing, stock, or lifecycle information?

Click below to explore more details on WIN SOURCE:

 [View CD74HC4094PWR on WIN SOURCE](#)

 [Texas Instruments](#) Information

Optimize Your Supply Chain with WIN SOURCE Solutions

-  Global Sourcing Solution
-  Obsolete Management
-  Cost Control Management
-  Shortage Management
-  Alternative Solution
-  Excess Inventory Management