



**THE DATASHEET OF
TRS207CDBR**



FEATURES

- ESD Protection for RS-232 Bus Pins
 - ± 15 -kV Human-Body Model (HBM)
- Meets or Exceeds the Requirements of TIA/EIA-232-F and ITU v.28 Standards
- Operates at 5-V V_{CC} Supply
- Operates up to 120 kbit/s
- External Capacitors . . . $4 \times 0.1 \mu\text{F}$
- Latch-Up Performance Exceeds 100 mA Per JESD 78, Class II

APPLICATIONS

- Battery-Powered Systems
- PDAs
- Notebooks
- Laptops
- Palmtop PCs
- Hand-Held Equipment

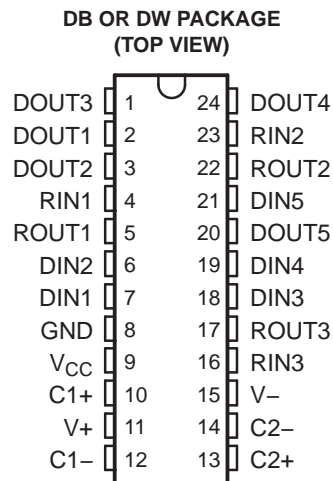

DESCRIPTION/ORDERING INFORMATION

The TRS207 consists of five line drivers, three line receivers, and a dual charge-pump circuit with ± 15 -kV ESD protection pin to pin (serial-port connection pins, including GND). The device meets the requirements of TIA/EIA-232-F and provides the electrical interface between an asynchronous communication controller and the serial-port connector. The charge pump and four small external capacitors allow operation from a single 5-V supply. The devices operate at data signaling rates up to 120 kbit/s and a maximum of 30-V/ μs driver output slew rate.

ORDERING INFORMATION

T_A	PACKAGE ⁽¹⁾⁽²⁾		ORDERABLE PART NUMBER	TOP-SIDE MARKING
0°C to 70°C	SOIC – DW	Tube of 25	TRS207CDW	TRS207C
		Reel of 2000	TRS207CDWR	
	SSOP – DB	Reel of 2000	TRS207CDBR	RU07C
–40°C to 85°C	SOIC – DW	Tube of 25	TRS207IDW	TRS207I
		Reel of 2000	TRS207IDWR	
	SSOP – DB	Reel of 2000	TRS207IDBR	RU07I

- (1) Package drawings, standard packing quantities, thermal data, symbolization, and PCB design guidelines are available at www.ti.com/sc/package.
- (2) For the most current package and ordering information, see the Package Option Addendum at the end of this document, or see the TI Web site at www.ti.com.



Please be aware that an important notice concerning availability, standard warranty, and use in critical applications of Texas Instruments semiconductor products and disclaimers thereto appears at the end of this data sheet.

FUNCTION TABLES

Each Driver⁽¹⁾

INPUT DIN	OUTPUT DOUT
L	H
H	L

(1) H = high level, L = low level

Each Receiver⁽¹⁾

INPUT RIN	OUTPUT ROUT
L	H
H	L
Open	H

(1) H = high level, L = low level,
 Open = input disconnected or
 connected driver off

LOGIC DIAGRAM (POSITIVE LOGIC)

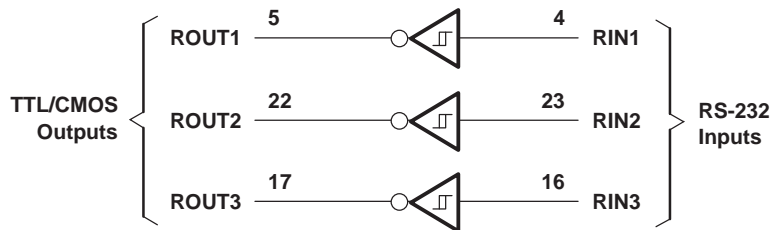
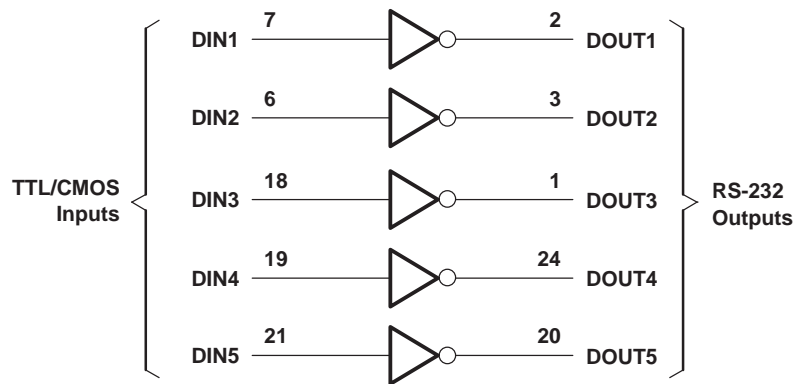

Absolute Maximum Ratings⁽¹⁾

over operating free-air temperature range (unless otherwise noted)

		MIN	MAX	UNIT
V _{CC}	Supply voltage range ⁽²⁾	-0.3	6	V
V+	Positive output supply voltage range ⁽²⁾	V _{CC} - 0.3	14	V
V-	Negative output supply voltage range ⁽²⁾	-14	0.3	V
V _I	Input voltage range	Drivers	V+ + 0.3	V
		Receivers	±30	
V _O	Output voltage range	Drivers	V- - 0.3	V
		Receivers	-0.3	
	Short-circuit duration	DOUT		Continuous
θ _{JA}	Package thermal impedance ⁽³⁾⁽⁴⁾	DB package		63
		DW package		46
T _J	Operating virtual junction temperature			150
T _{stg}	Storage temperature range	-65	150	°C

- (1) Stresses beyond those listed under "absolute maximum ratings" may cause permanent damage to the device. These are stress ratings only, and functional operation of the device at these or any other conditions beyond those indicated under "recommended operating conditions" is not implied. Exposure to absolute-maximum-rated conditions for extended periods may affect device reliability.
- (2) All voltages are with respect to network GND.
- (3) Maximum power dissipation is a function of T_J(max), θ_{JA}, and T_A. The maximum allowable power dissipation at any allowable ambient temperature is P_D = (T_J(max) - T_A)/θ_{JA}. Operating at the absolute maximum T_J of 150°C can affect reliability.
- (4) The package thermal impedance is calculated in accordance with JESD 51-7.

Recommended Operating Conditions⁽¹⁾

See [Figure 4](#)

		MIN	NOM	MAX	UNIT
Supply voltage		4.5	5	5.5	V
V _{IH}	Driver high-level input voltage	DIN		2	V
V _{IL}	Driver low-level input voltage	DIN		0.8	V
V _I	Driver input voltage	DIN		0	V
	Receiver input voltage			30	
T _A	Operating free-air temperature	TRS207C		0	°C
		TRS207I		-40	

- (1) Test conditions are C1–C4 = 0.1 μF at V_{CC} = 5 V ± 0.5 V.

Electrical Characteristics⁽¹⁾

over recommended ranges of supply voltage (unless otherwise noted) (see [Figure 4](#))

PARAMETER	TEST CONDITIONS			MIN	TYP	MAX	UNIT
I _{CC}	Supply current	No load,	V _{CC} = 5 V, T _A = 25°C		11	20	mA

- (1) Test conditions are C1–C4 = 0.1 μF at V_{CC} = 5 V ± 0.5 V.

TRS207

5-V MULTICHANNEL RS-232 LINE DRIVER/RECEIVER WITH ± 15 -kV ESD PROTECTION

SLLS809–JUNE 2007

DRIVER SECTION

Electrical Characteristics⁽¹⁾

over recommended ranges of supply voltage and operating free-air temperature (unless otherwise noted) (see [Figure 4](#))

PARAMETER	TEST CONDITIONS	MIN	TYP ⁽²⁾	MAX	UNIT
V _{OH}	High-level output voltage DOUT at R _L = 3 k Ω to GND, DIN = GND	5	9		V
V _{OL}	Low-level output voltage DOUT at R _L = 3 k Ω to GND, DIN = V _{CC}	–5	–9		V
I _{IH}	High-level input current V _I = V _{CC}		15	200	μ A
I _{IL}	Low-level input current V _I at 0 V		–15	–200	μ A
I _{OS} ⁽³⁾	Short-circuit output current V _{CC} = 5.5 V, V _O = 0 V		± 10	± 60	mA
r _o	Output resistance V _{CC} , V+, and V– = 0 V, V _O = ± 2 V	300			Ω

(1) Test conditions are C1–C4 = 0.1 μ F at V_{CC} = 5 V \pm 0.5 V.

(2) All typical values are at V_{CC} = 5 V, and T_A = 25°C.

(3) Short-circuit durations should be controlled to prevent exceeding the device absolute power dissipation ratings, and not more than one output should be shorted at a time.

Switching Characteristics⁽¹⁾

over recommended ranges of supply voltage and operating free-air temperature (unless otherwise noted) (see [Figure 4](#))

PARAMETER	TEST CONDITIONS	MIN	TYP ⁽²⁾	MAX	UNIT
Maximum data rate	C _L = 50 pF to 1000 pF, One DOUT switching, R _L = 3 k Ω to 7 k Ω , See Figure 1	120			kbit/s
t _{PLH(D)}	Propagation delay time, low- to high-level output C _L = 2500 pF, All drivers loaded, R _L = 3 k Ω , See Figure 1		2		μ s
t _{PHL(D)}	Propagation delay time, high- to low-level output C _L = 2500 pF, All drivers loaded, R _L = 3 k Ω , See Figure 1		2		μ s
t _{sk(p)}	Pulse skew ⁽³⁾ C _L = 150 pF to 2500 pF, See Figure 2 , R _L = 3 k Ω to 7 k Ω ,		300		ns
SR(tr)	Slew rate, transition region (see Figure 1) C _L = 50 pF to 1000 pF, V _{CC} = 5 V, R _L = 3 k Ω to 7 k Ω ,	3	6	30	V/ μ s

(1) Test conditions are C1–C4 = 0.1 μ F at V_{CC} = 5 V \pm 0.5 V.

(2) All typical values are at V_{CC} = 5 V, and T_A = 25°C.

(3) Pulse skew is defined as |t_{PLH} – t_{PHL}| of each channel of the same device.

ESD Protection

PIN	TEST CONDITIONS	TYP	UNIT
DOUT, RIN	Human-Body Model	± 15	kV

RECEIVER SECTION

Electrical Characteristics⁽¹⁾

over recommended ranges of supply voltage and operating free-air temperature (unless otherwise noted) (see [Figure 4](#))

PARAMETER		TEST CONDITIONS	MIN	TYP ⁽²⁾	MAX	UNIT
V _{OH}	High-level output voltage	I _{OH} = -1 mA	3.5	V _{CC} - 0.4		V
V _{OL}	Low-level output voltage	I _{OL} = 1.6 mA			0.4	V
V _{IT+}	Positive-going input threshold voltage	V _{CC} = 5 V, T _A = 25°C		1.7	2.4	V
V _{IT-}	Negative-going input threshold voltage	V _{CC} = 5 V, T _A = 25°C	0.8	1.2		V
V _{hys}	Input hysteresis (V _{IT+} - V _{IT-})		0.2	0.5	1	V
r _i	Input resistance	V _I = ± 3 V to ± 25 V	3	5	7	k Ω

(1) Test conditions are C1–C4 = 0.1 μ F at V_{CC} = 5 V \pm 0.5 V.

(2) All typical values are at V_{CC} = 5 V, and T_A = 25°C.

Switching Characteristics⁽¹⁾

over recommended ranges of supply voltage and operating free-air temperature (unless otherwise noted) (see [Figure 3](#))

PARAMETER		TEST CONDITIONS	MIN	TYP ⁽²⁾	MAX	UNIT
t _{PLH}	Propagation delay time, low- to high-level output	C _L = 150 pF		0.5	10	μ s
t _{PHL}	Propagation delay time, high- to low-level output			0.5	10	μ s
t _{sk(p)}	Pulse skew ⁽³⁾			300		ns

(1) Test conditions are C1–C4 = 0.1 μ F at V_{CC} = 5 V \pm 0.5 V.

(2) All typical values are at V_{CC} = 5 V, and T_A = 25°C.

(3) Pulse skew is defined as |t_{PLH} - t_{PHL}| of each channel of the same device.

PARAMETER MEASUREMENT INFORMATION

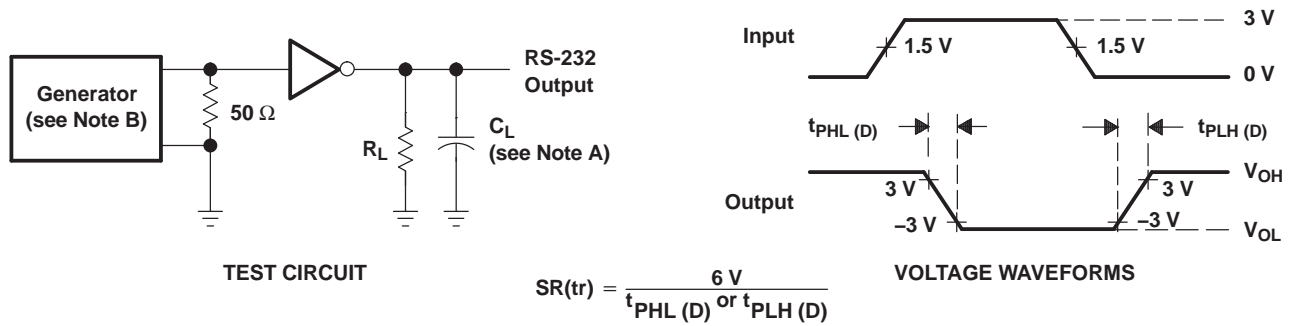

- A. C_L includes probe and jig capacitance.
- B. The pulse generator has the following characteristics: PRR = 120 kbit/s, $Z_O = 50\ \Omega$, 50% duty cycle, $t_r \leq 10\ \text{ns}$, $t_f \leq 10\ \text{ns}$.

Figure 1. Driver Slew Rate

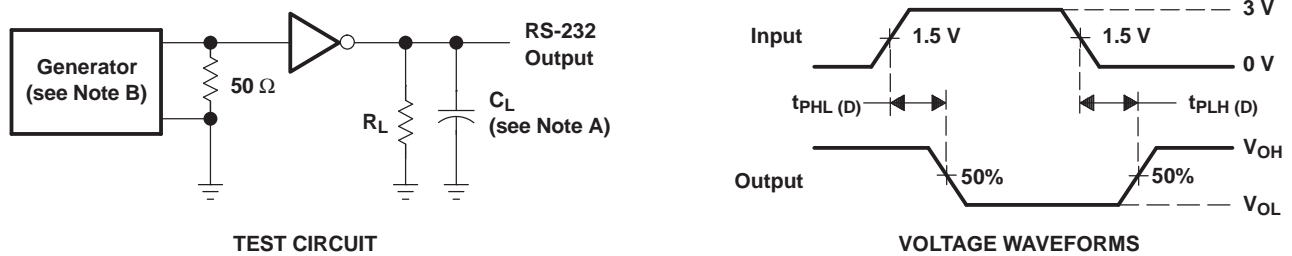

- A. C_L includes probe and jig capacitance.
- B. The pulse generator has the following characteristics: PRR = 120 kbit/s, $Z_O = 50\ \Omega$, 50% duty cycle, $t_r \leq 10\ \text{ns}$, $t_f \leq 10\ \text{ns}$.

Figure 2. Driver Pulse Skew

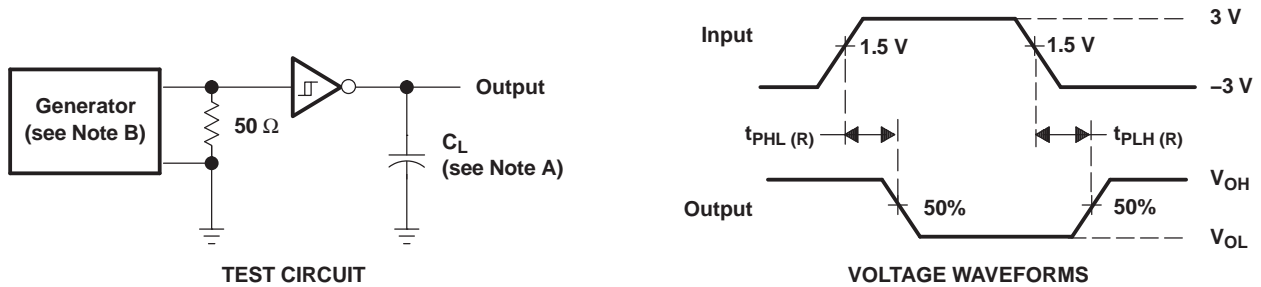

- A. C_L includes probe and jig capacitance.
- B. The pulse generator has the following characteristics: $Z_O = 50\ \Omega$, 50% duty cycle, $t_r \leq 10\ \text{ns}$, $t_f \leq 10\ \text{ns}$.

Figure 3. Receiver Propagation Delay Times

APPLICATION INFORMATION

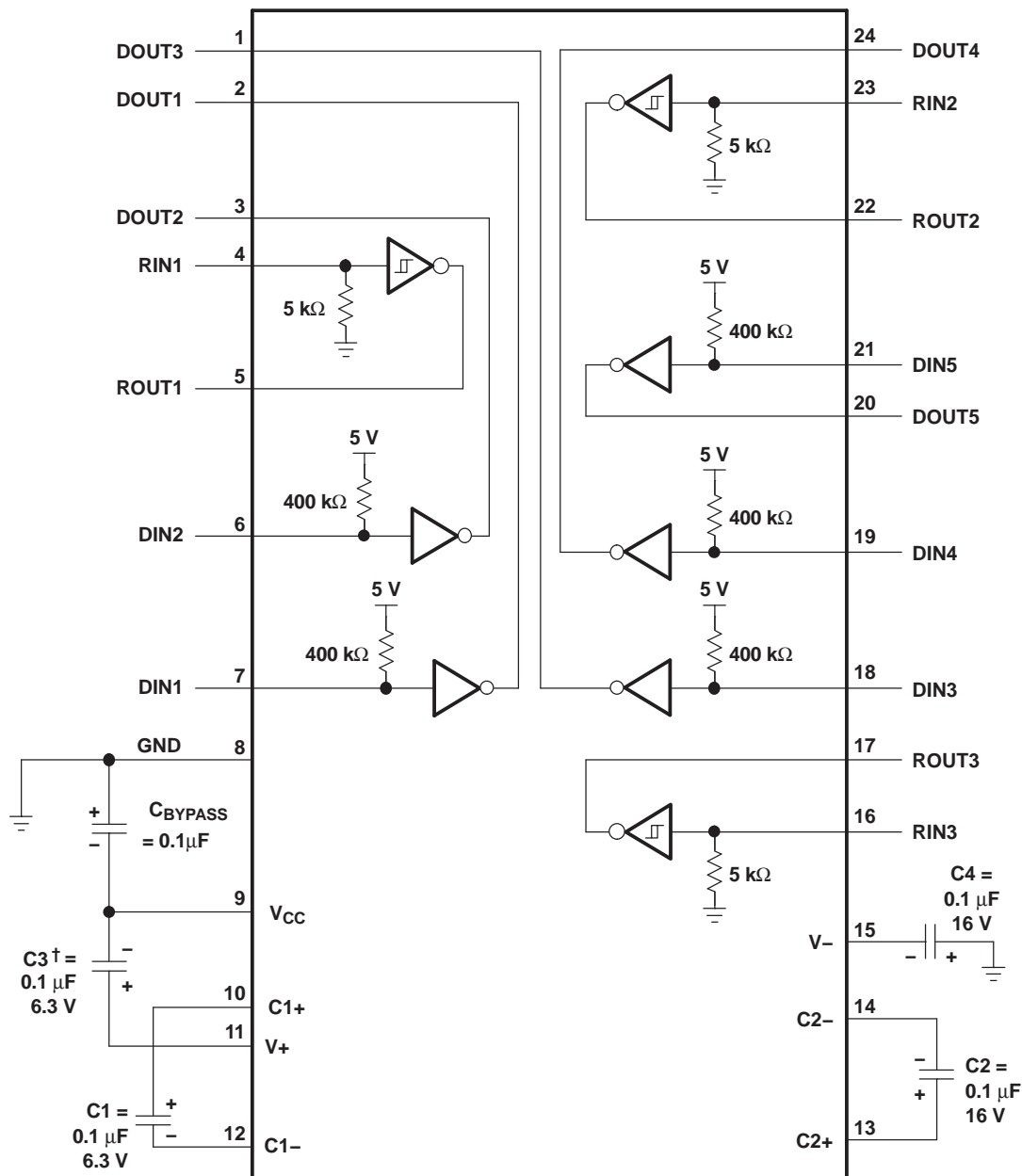

† C3 can be connected to V_{CC} or GND.

- A. Resistor values shown are nominal.
- B. Nonpolarized ceramic capacitors are acceptable. If polarized tantalum or electrolytic capacitors are used, they should be connected as shown.

Figure 4. Typical Operating Circuit and Capacitor Values

APPLICATION INFORMATION (continued)

Capacitor Selection

The capacitor type used for C1–C4 is not critical for proper operation. The TRS207 requires 0.1- μ F capacitors, although capacitors up to 10 μ F can be used without harm. Ceramic dielectrics are suggested for the 0.1- μ F capacitors. When using the minimum recommended capacitor values, make sure the capacitance value does not degrade excessively as the operating temperature varies. If in doubt, use capacitors with a larger (e.g., 2 \times) nominal value. The capacitors' effective series resistance (ESR), which usually rises at low temperatures, influences the amount of ripple on V+ and V–.

Use larger capacitors (up to 10 μ F) to reduce the output impedance at V+ and V–.

Bypass V_{CC} to ground with at least 0.1 μ F. In applications sensitive to power-supply noise generated by the charge pumps, decouple V_{CC} to ground with a capacitor the same size as (or larger than) the charge-pump capacitors (C1–C4).

Electrostatic Discharge (ESD) Protection

TI TRS207 devices have standard ESD protection structures incorporated on the pins to protect against electrostatic discharges encountered during assembly and handling. In addition, the RS-232 bus pins (driver outputs and receiver inputs) of these devices have an extra level of ESD protection. Advanced ESD structures were designed to successfully protect these bus pins against ESD discharge of ± 15 -kV when powered down.

ESD Test Conditions

ESD testing is stringently performed by TI, based on various conditions and procedures. Please contact TI for a reliability report that documents test setup, methodology, and results.

Human-Body Model (HBM)

The HBM of ESD testing is shown in Figure 5, while Figure 6 shows the current waveform that is generated during a discharge into a low impedance. The model consists of a 100-pF capacitor, charged to the ESD voltage of concern, and subsequently discharged into the DUT through a 1.5-k Ω resistor.

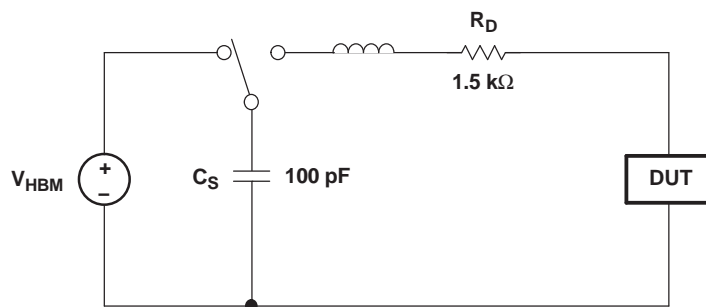

Figure 5. HBM ESD Test Circuit

APPLICATION INFORMATION (continued)

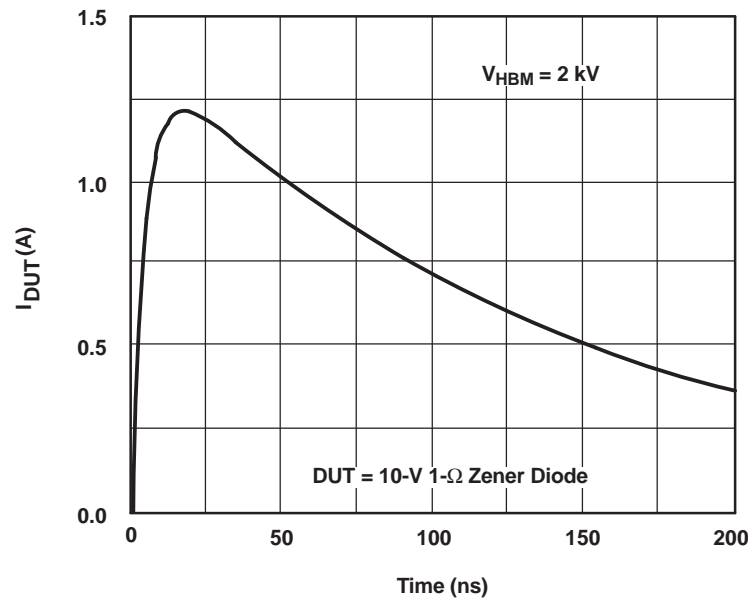

Figure 6. Typical HBM Current Waveform

Machine Model (MM)

The MM ESD test applies to all pins using a 200-pF capacitor with no discharge resistance. The purpose of the MM test is to simulate possible ESD conditions that can occur during the handling and assembly processes of manufacturing. In this case, ESD protection is required for all pins, not just RS-232 pins. However, after PC board assembly, the MM test is no longer as pertinent to the RS-232 pins.

PACKAGING INFORMATION

Orderable Device	Status (1)	Package Type	Package Drawing	Pins	Package Qty	Eco Plan (2)	Lead/Ball Finish (6)	MSL Peak Temp (3)	Op Temp (°C)	Device Marking (4/5)	Samples
TRS207CDBR	ACTIVE	SSOP	DB	24	2000	Green (RoHS & no Sb/Br)	CU NIPDAU	Level-1-260C-UNLIM	0 to 70	RU07C	Samples

(1) The marketing status values are defined as follows:

ACTIVE: Product device recommended for new designs.

LIFEBUY: TI has announced that the device will be discontinued, and a lifetime-buy period is in effect.

NRND: Not recommended for new designs. Device is in production to support existing customers, but TI does not recommend using this part in a new design.

PREVIEW: Device has been announced but is not in production. Samples may or may not be available.

OBSOLETE: TI has discontinued the production of the device.

(2) Eco Plan - The planned eco-friendly classification: Pb-Free (RoHS), Pb-Free (RoHS Exempt), or Green (RoHS & no Sb/Br) - please check <http://www.ti.com/productcontent> for the latest availability information and additional product content details.

TBD: The Pb-Free/Green conversion plan has not been defined.

Pb-Free (RoHS): TI's terms "Lead-Free" or "Pb-Free" mean semiconductor products that are compatible with the current RoHS requirements for all 6 substances, including the requirement that lead not exceed 0.1% by weight in homogeneous materials. Where designed to be soldered at high temperatures, TI Pb-Free products are suitable for use in specified lead-free processes.

Pb-Free (RoHS Exempt): This component has a RoHS exemption for either 1) lead-based flip-chip solder bumps used between the die and package, or 2) lead-based die adhesive used between the die and leadframe. The component is otherwise considered Pb-Free (RoHS compatible) as defined above.

Green (RoHS & no Sb/Br): TI defines "Green" to mean Pb-Free (RoHS compatible), and free of Bromine (Br) and Antimony (Sb) based flame retardants (Br or Sb do not exceed 0.1% by weight in homogeneous material)

(3) MSL, Peak Temp. - The Moisture Sensitivity Level rating according to the JEDEC industry standard classifications, and peak solder temperature.

(4) There may be additional marking, which relates to the logo, the lot trace code information, or the environmental category on the device.

(5) Multiple Device Markings will be inside parentheses. Only one Device Marking contained in parentheses and separated by a "~" will appear on a device. If a line is indented then it is a continuation of the previous line and the two combined represent the entire Device Marking for that device.

(6) Lead/Ball Finish - Orderable Devices may have multiple material finish options. Finish options are separated by a vertical ruled line. Lead/Ball Finish values may wrap to two lines if the finish value exceeds the maximum column width.

Important Information and Disclaimer: The information provided on this page represents TI's knowledge and belief as of the date that it is provided. TI bases its knowledge and belief on information provided by third parties, and makes no representation or warranty as to the accuracy of such information. Efforts are underway to better integrate information from third parties. TI has taken and continues to take reasonable steps to provide representative and accurate information but may not have conducted destructive testing or chemical analysis on incoming materials and chemicals. TI and TI suppliers consider certain information to be proprietary, and thus CAS numbers and other limited information may not be available for release.

In no event shall TI's liability arising out of such information exceed the total purchase price of the TI part(s) at issue in this document sold by TI to Customer on an annual basis.

TAPE AND REEL INFORMATION

REEL DIMENSIONS

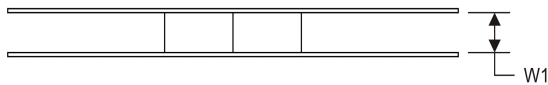
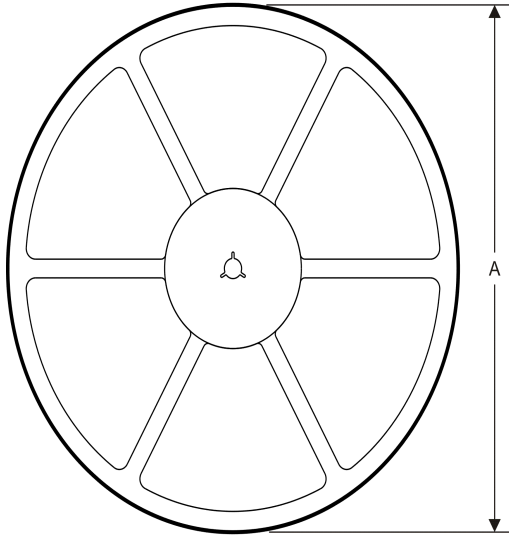

TAPE DIMENSIONS

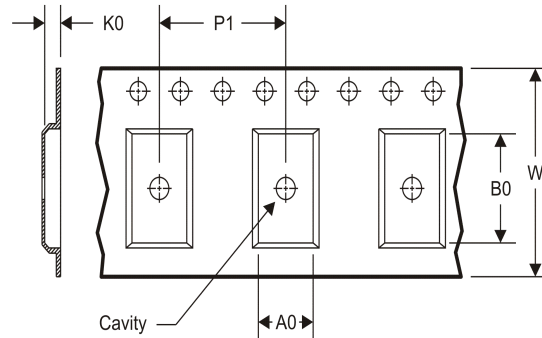

A0	Dimension designed to accommodate the component width
B0	Dimension designed to accommodate the component length
K0	Dimension designed to accommodate the component thickness
W	Overall width of the carrier tape
P1	Pitch between successive cavity centers

TAPE AND REEL INFORMATION

*All dimensions are nominal

Device	Package Type	Package Drawing	Pins	SPQ	Reel Diameter (mm)	Reel Width W1 (mm)	A0 (mm)	B0 (mm)	K0 (mm)	P1 (mm)	W (mm)	Pin1 Quadrant
TRS207CDBR	SSOP	DB	24	2000	330.0	16.4	8.2	8.8	2.5	12.0	16.0	Q1

TAPE AND REEL BOX DIMENSIONS



*All dimensions are nominal

Device	Package Type	Package Drawing	Pins	SPQ	Length (mm)	Width (mm)	Height (mm)
TRS207CDBR	SSOP	DB	24	2000	367.0	367.0	38.0

DB (R-PDSO-G**)

PLASTIC SMALL-OUTLINE

28 PINS SHOWN



- NOTES: A. All linear dimensions are in millimeters.
 B. This drawing is subject to change without notice.
 C. Body dimensions do not include mold flash or protrusion not to exceed 0,15.
 D. Falls within JEDEC MO-150

IMPORTANT NOTICE

Texas Instruments Incorporated (TI) reserves the right to make corrections, enhancements, improvements and other changes to its semiconductor products and services per JESD46, latest issue, and to discontinue any product or service per JESD48, latest issue. Buyers should obtain the latest relevant information before placing orders and should verify that such information is current and complete.

TI's published terms of sale for semiconductor products (<http://www.ti.com/sc/docs/stdterms.htm>) apply to the sale of packaged integrated circuit products that TI has qualified and released to market. Additional terms may apply to the use or sale of other types of TI products and services.

Reproduction of significant portions of TI information in TI data sheets is permissible only if reproduction is without alteration and is accompanied by all associated warranties, conditions, limitations, and notices. TI is not responsible or liable for such reproduced documentation. Information of third parties may be subject to additional restrictions. Resale of TI products or services with statements different from or beyond the parameters stated by TI for that product or service voids all express and any implied warranties for the associated TI product or service and is an unfair and deceptive business practice. TI is not responsible or liable for any such statements.

Buyers and others who are developing systems that incorporate TI products (collectively, "Designers") understand and agree that Designers remain responsible for using their independent analysis, evaluation and judgment in designing their applications and that Designers have full and exclusive responsibility to assure the safety of Designers' applications and compliance of their applications (and of all TI products used in or for Designers' applications) with all applicable regulations, laws and other applicable requirements. Designer represents that, with respect to their applications, Designer has all the necessary expertise to create and implement safeguards that (1) anticipate dangerous consequences of failures, (2) monitor failures and their consequences, and (3) lessen the likelihood of failures that might cause harm and take appropriate actions. Designer agrees that prior to using or distributing any applications that include TI products, Designer will thoroughly test such applications and the functionality of such TI products as used in such applications.

TI's provision of technical, application or other design advice, quality characterization, reliability data or other services or information, including, but not limited to, reference designs and materials relating to evaluation modules, (collectively, "TI Resources") are intended to assist designers who are developing applications that incorporate TI products; by downloading, accessing or using TI Resources in any way, Designer (individually or, if Designer is acting on behalf of a company, Designer's company) agrees to use any particular TI Resource solely for this purpose and subject to the terms of this Notice.

TI's provision of TI Resources does not expand or otherwise alter TI's applicable published warranties or warranty disclaimers for TI products, and no additional obligations or liabilities arise from TI providing such TI Resources. TI reserves the right to make corrections, enhancements, improvements and other changes to its TI Resources. TI has not conducted any testing other than that specifically described in the published documentation for a particular TI Resource.

Designer is authorized to use, copy and modify any individual TI Resource only in connection with the development of applications that include the TI product(s) identified in such TI Resource. NO OTHER LICENSE, EXPRESS OR IMPLIED, BY ESTOPPEL OR OTHERWISE TO ANY OTHER TI INTELLECTUAL PROPERTY RIGHT, AND NO LICENSE TO ANY TECHNOLOGY OR INTELLECTUAL PROPERTY RIGHT OF TI OR ANY THIRD PARTY IS GRANTED HEREIN, including but not limited to any patent right, copyright, mask work right, or other intellectual property right relating to any combination, machine, or process in which TI products or services are used. Information regarding or referencing third-party products or services does not constitute a license to use such products or services, or a warranty or endorsement thereof. Use of TI Resources may require a license from a third party under the patents or other intellectual property of the third party, or a license from TI under the patents or other intellectual property of TI.

TI RESOURCES ARE PROVIDED "AS IS" AND WITH ALL FAULTS. TI DISCLAIMS ALL OTHER WARRANTIES OR REPRESENTATIONS, EXPRESS OR IMPLIED, REGARDING RESOURCES OR USE THEREOF, INCLUDING BUT NOT LIMITED TO ACCURACY OR COMPLETENESS, TITLE, ANY EPIDEMIC FAILURE WARRANTY AND ANY IMPLIED WARRANTIES OF MERCHANTABILITY, FITNESS FOR A PARTICULAR PURPOSE, AND NON-INFRINGEMENT OF ANY THIRD PARTY INTELLECTUAL PROPERTY RIGHTS. TI SHALL NOT BE LIABLE FOR AND SHALL NOT DEFEND OR INDEMNIFY DESIGNER AGAINST ANY CLAIM, INCLUDING BUT NOT LIMITED TO ANY INFRINGEMENT CLAIM THAT RELATES TO OR IS BASED ON ANY COMBINATION OF PRODUCTS EVEN IF DESCRIBED IN TI RESOURCES OR OTHERWISE. IN NO EVENT SHALL TI BE LIABLE FOR ANY ACTUAL, DIRECT, SPECIAL, COLLATERAL, INDIRECT, PUNITIVE, INCIDENTAL, CONSEQUENTIAL OR EXEMPLARY DAMAGES IN CONNECTION WITH OR ARISING OUT OF TI RESOURCES OR USE THEREOF, AND REGARDLESS OF WHETHER TI HAS BEEN ADVISED OF THE POSSIBILITY OF SUCH DAMAGES.

Unless TI has explicitly designated an individual product as meeting the requirements of a particular industry standard (e.g., ISO/TS 16949 and ISO 26262), TI is not responsible for any failure to meet such industry standard requirements.

Where TI specifically promotes products as facilitating functional safety or as compliant with industry functional safety standards, such products are intended to help enable customers to design and create their own applications that meet applicable functional safety standards and requirements. Using products in an application does not by itself establish any safety features in the application. Designers must ensure compliance with safety-related requirements and standards applicable to their applications. Designer may not use any TI products in life-critical medical equipment unless authorized officers of the parties have executed a special contract specifically governing such use. Life-critical medical equipment is medical equipment where failure of such equipment would cause serious bodily injury or death (e.g., life support, pacemakers, defibrillators, heart pumps, neurostimulators, and implantables). Such equipment includes, without limitation, all medical devices identified by the U.S. Food and Drug Administration as Class III devices and equivalent classifications outside the U.S.

TI may expressly designate certain products as completing a particular qualification (e.g., Q100, Military Grade, or Enhanced Product). Designers agree that it has the necessary expertise to select the product with the appropriate qualification designation for their applications and that proper product selection is at Designers' own risk. Designers are solely responsible for compliance with all legal and regulatory requirements in connection with such selection.

Designer will fully indemnify TI and its representatives against any damages, costs, losses, and/or liabilities arising out of Designer's non-compliance with the terms and provisions of this Notice.

Looking for pricing, stock, or lifecycle information?

Click below to explore more details on WIN SOURCE:

 [View TRS207CDBR](#) on WIN SOURCE

 [Texas Instruments](#) Information

Optimize Your Supply Chain with WIN SOURCE Solutions

-  Global Sourcing Solution
-  Obsolete Management
-  Cost Control Management
-  Shortage Management
-  Alternative Solution
-  Excess Inventory Management