

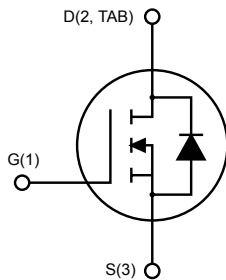

THE DATASHEET OF STD100N10F7

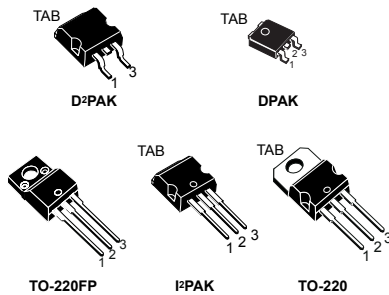

N-channel 100 V, 6.8 mΩ typ., 80 A STripFET™ F7 Power MOSFETs
in D²PAK, DPAK, TO-220FP, I²PAK and TO-220 packages



AM01475v1_noZen

Features

Order codes	V _{DS}	R _{DS(on)} max.	I _D	Package
STB100N10F7	100 V	8.0 mΩ	80 A	D ² PAK
STD100N10F7			80 A	DPAK
STF100N10F7			45 A	TO-220FP
STI100N10F7			80 A	I ² PAK
STP100N10F7			80 A	TO-220

- Among the lowest R_{DS(on)} on the market
- Excellent FoM (figure of merit)
- Low C_{rss}/C_{iss} ratio for EMI immunity
- High avalanche ruggedness

Applications

- Switching applications

Description

These N-channel Power MOSFETs utilize STripFET™ F7 technology with an enhanced trench gate structure that results in very low on-state resistance, while also reducing internal capacitance and gate charge for faster and more efficient switching.

Product status links

[STB100N10F7](#)
[STD100N10F7](#)
[STF100N10F7](#)
[STI100N10F7](#)
[STP100N10F7](#)

1 Electrical ratings

Table 1. Absolute maximum ratings

Symbol	Parameter	Value			Unit
		DPAK	TO-220FP	TO-220 D ² PAK I ² PAK	
V _{DS}	Drain-source voltage	100			V
V _{GS}	Gate-source voltage	±20			V
I _D	Drain current (continuous) at T _C = 25 °C	80	45 ⁽¹⁾	80	A
	Drain current (continuous) at T _C = 100 °C	62	32 ⁽¹⁾	70	A
I _{DM} ⁽²⁾	Drain current (pulsed)	320	180	320	A
P _{TOT} ⁽¹⁾	Total dissipation at T _C = 25 °C	120	30	150	W
V _{ISO}	Insulation withstand voltage (RMS) from all three leads to external heatsink (t = 1 s, T _C = 25 °C)	2.5			kV
T _J	Operating junction temperature	-55 to 175			°C
T _{stg}	Storage temperature range				°C

1. This value is limited by package.
2. Pulse width is limited by safe operating area.

Table 2. Thermal resistance

Symbol	Parameter	Value				Unit
		D ² PAK	DPAK	TO-220FP	TO-220 I ² PAK	
R _{thj-case}	Thermal resistance junction-case	1	1.25	5	1	°C/W
R _{thj-amb}	Thermal resistance junction-ambient	62.5				°C/W
R _{thj-pcb} ⁽¹⁾	Thermal resistance junction-pcb	30	50			°C/W

1. When mounted on an 1-inch² FR-4 board, 2oz CU, t < 10 s.

Table 3. Avalanche characteristics

Symbol	Parameter	Value	Unit
E _{AS}	Single pulse avalanche energy (T _J = 25 °C, L = 3.5 mH, I _{AS} = 15 A, V _{DD} = 50 V, V _{GS} = 10 V)	400	mJ

2 Electrical characteristics

($T_{CASE} = 25\text{ °C}$ unless otherwise specified)

Table 4. On-/off-states

Symbol	Parameter	Test conditions	Min.	Typ.	Max.	Unit
$V_{(BR)DSS}$	Drain-source breakdown voltage	$I_D = 250\ \mu\text{A}$, $V_{GS} = 0\ \text{V}$	100			V
I_{DSS}	Zero gate voltage drain current	$V_{DS} = 100\ \text{V}$, $V_{GS} = 0\ \text{V}$			1	μA
		$V_{DS} = 100\ \text{V}$, $V_{GS} = 0\ \text{V}$, $T_C = 125\text{ °C}^{(1)}$			100	μA
I_{GSS}	Gate-body leakage current	$V_{GS} = 20\ \text{V}$, $V_{DS} = 0\ \text{V}$			100	nA
$V_{GS(th)}$	Gate threshold voltage	$V_{DS} = V_{GS}$, $I_D = 250\ \mu\text{A}$	2.5		4.5	V
$R_{DS(on)}$	Static drain-source on-resistance	For D²PAK, DPAK, I²PAK and TO-220: $V_{GS} = 10\ \text{V}$, $I_D = 40\ \text{A}$ For TO-220FP: $V_{GS} = 10\ \text{V}$, $I_D = 22.5\ \text{A}$		6.8	8.0	m Ω

1. Defined by design, not subject to production test.

Table 5. Dynamic

Symbol	Parameter	Test conditions	Min.	Typ.	Max.	Unit
C_{iss}	Input capacitance	$V_{DS} = 50\ \text{V}$, $f = 1\ \text{MHz}$, $V_{GS} = 0\ \text{V}$	-	4369	-	pF
C_{oss}	Output capacitance		-	823	-	pF
C_{riss}	Reverse transfer capacitance		-	36	-	pF
Q_g	Total gate charge	$V_{DD} = 50\ \text{V}$, $I_D = 80\ \text{A}$, $V_{GS} = 0$ to $10\ \text{V}$ (see Figure 17. Test circuit for gate charge behavior)	-	61	-	nC
Q_{gs}	Gate-source charge		-	26	-	nC
Q_{gd}	Gate-drain charge		-	13	-	nC

Table 6. Switching times

Symbol	Parameter	Test conditions	Min.	Typ.	Max.	Unit
$t_{d(on)}$	Turn-on delay time	$V_{DD} = 50\ \text{V}$, $I_D = 40\ \text{A}$, $R_G = 4.7\ \Omega$, $V_{GS} = 10\ \text{V}$	-	27	-	ns
t_r	Rise time		-	40	-	ns
$t_{d(off)}$	Turn-off delay time	(see Figure 16. Test circuit for resistive load switching times and Figure 21. Switching time waveform)	-	46	-	ns
t_f	Fall time		-	15	-	ns

Table 7. Source-drain diode

Symbol	Parameter	Test conditions	Min.	Typ.	Max.	Unit
I_{SD}	Source-drain current		-		80	A
$I_{SDM}^{(1)}$	Source-drain current (pulsed)		-		320	A
$V_{SD}^{(2)}$	Forward on voltage	$I_{SD} = 80 \text{ A}$, $V_{GS} = 0 \text{ V}$	-		1.2	V
t_{rr}	Reverse recovery time	$I_{SD} = 80 \text{ A}$, $di/dt = 100 \text{ A}/\mu\text{s}$	-	77		ns
Q_{rr}	Reverse recovery charge	$V_{DD} = 80 \text{ V}$, $T_J = 150 \text{ }^\circ\text{C}$	-	146		nC
I_{RRM}	Reverse recovery current	(see Figure 18. Test circuit for inductive load switching and diode recovery times)	-	4		A

1. Pulse width is limited by safe operating area.
2. Pulsed: pulse duration = 300 μs , duty cycle 1.5%

2.1 Electrical characteristics (curves)
Figure 1. Safe operating area for DPAK

Figure 2. Thermal impedance for DPAK

Figure 3. Safe operating area for TO-220FP

Figure 4. Thermal impedance for TO-220FP

Figure 5. Safe operating area for D²PAK, I²PAK and TO-220

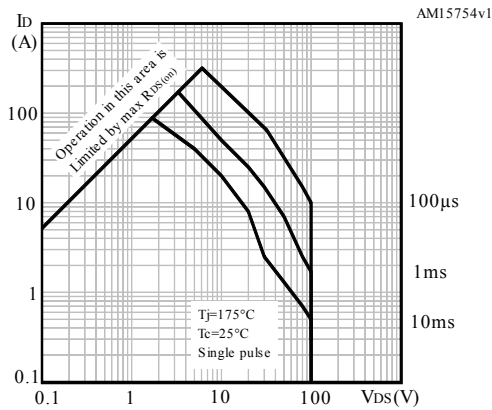
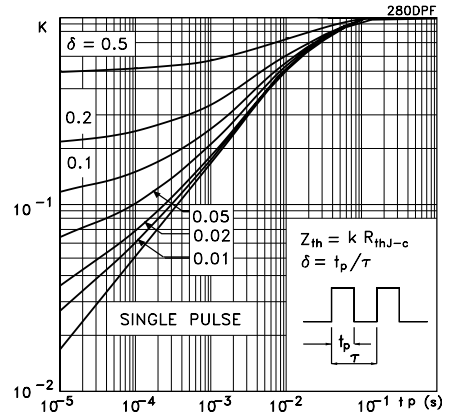
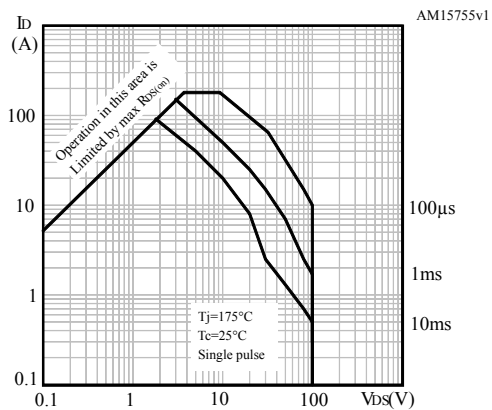
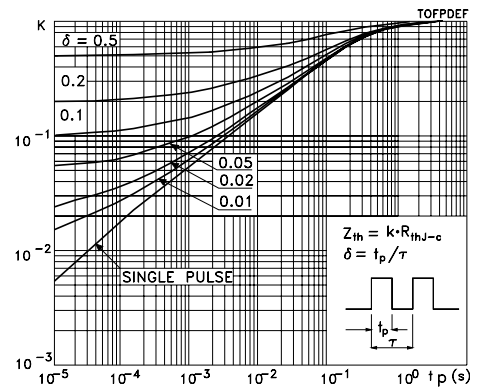
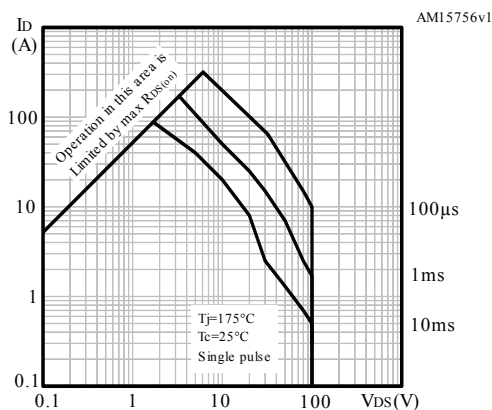
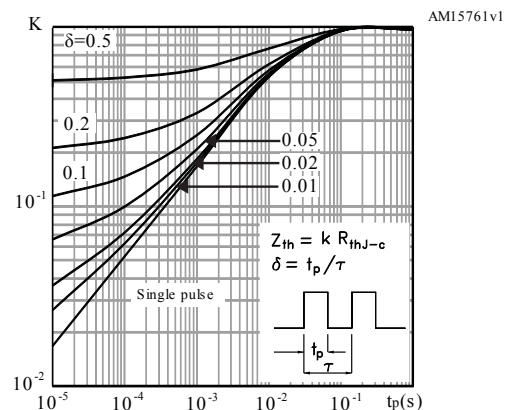
Figure 6. Thermal impedance for D²PAK, I²PAK and TO-220

Figure 7. Output characteristics

Figure 8. Transfer characteristics

Figure 9. Normalized $V_{(BR)DSS}$ vs temperature

Figure 10. Static drain-source on-resistance

Figure 11. Gate charge vs gate-source voltage

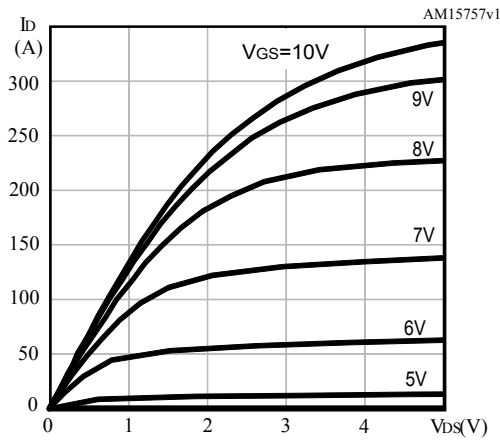
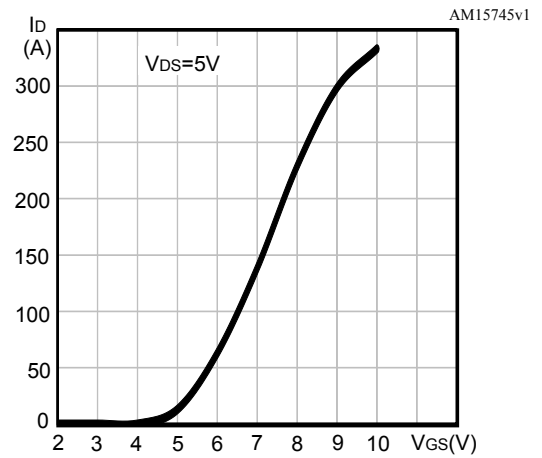
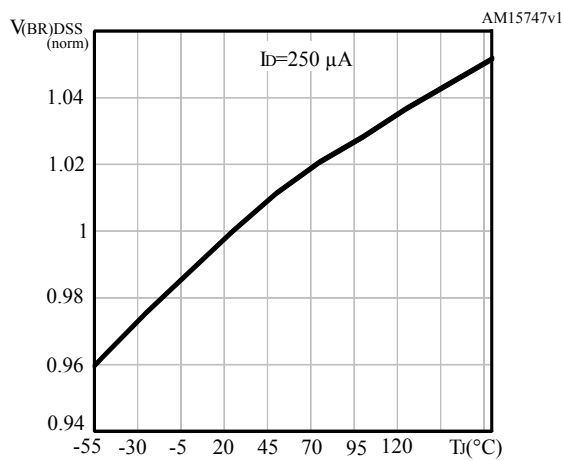
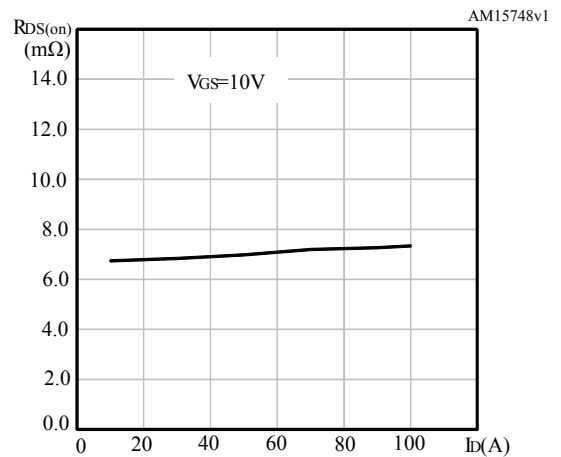
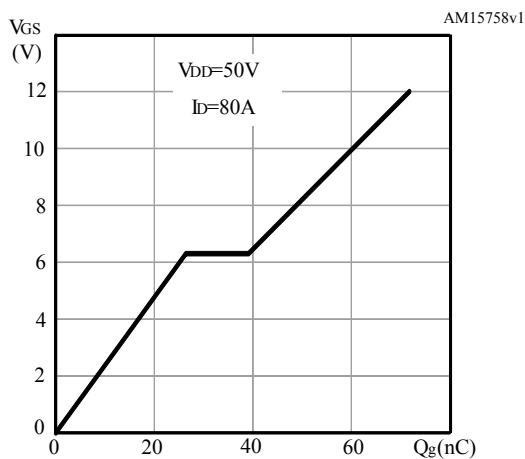
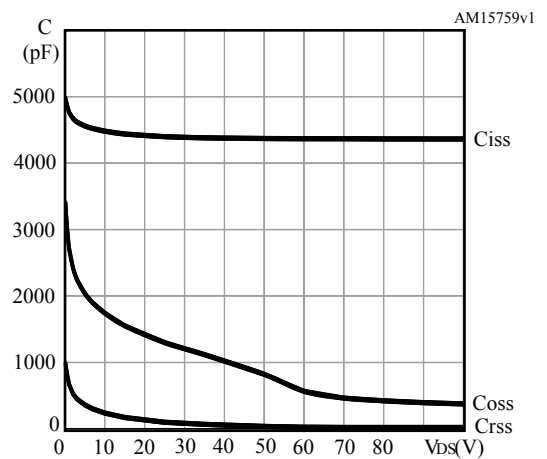
Figure 12. Capacitance variations

Figure 13. Normalized gate threshold voltage vs temperature

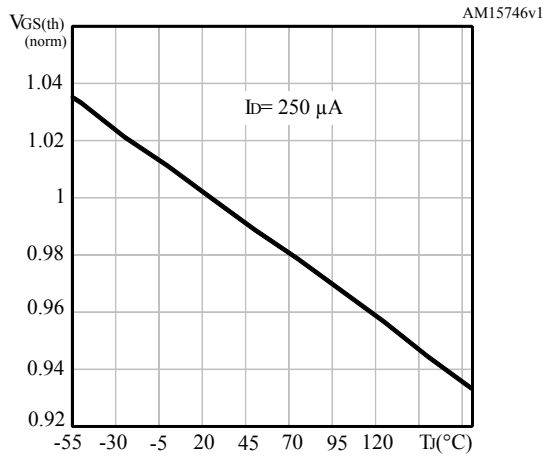

Figure 14. Normalized on-resistance vs temperature

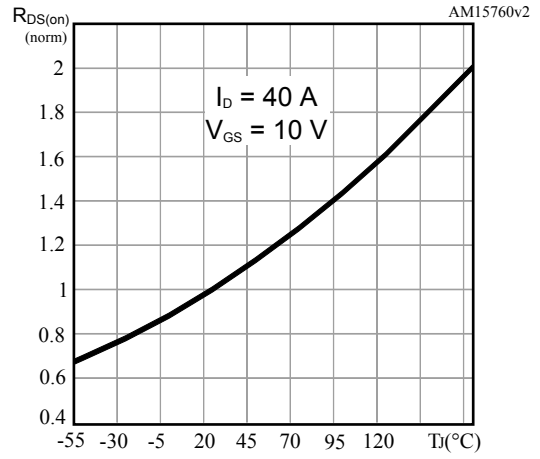
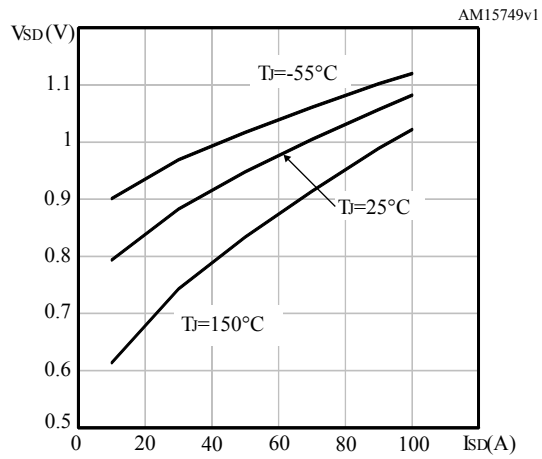
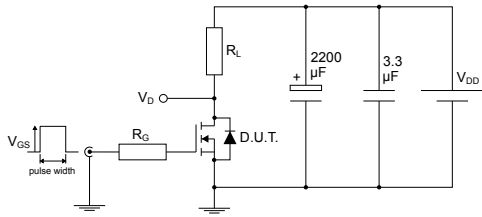

Figure 15. Source-drain diode forward characteristics



3 Test circuits

Figure 16. Test circuit for resistive load switching times



AM01468v1

Figure 17. Test circuit for gate charge behavior

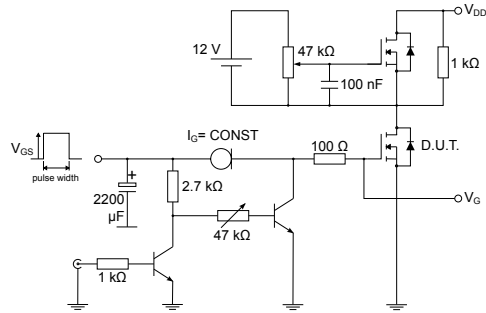

AM01469v1

Figure 18. Test circuit for inductive load switching and diode recovery times



AM01470v1

Figure 19. Unclamped inductive load test circuit



AM01471v1

Figure 20. Unclamped inductive waveform



AM01472v1

Figure 21. Switching time waveform

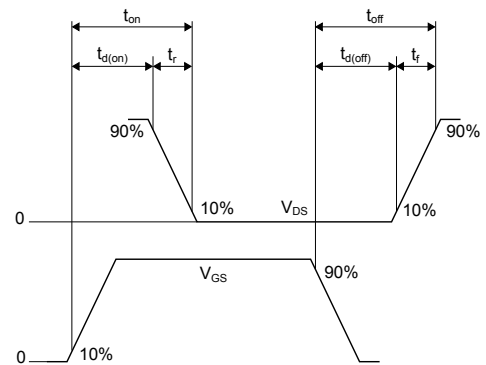

AM01473v1



4 Package information

In order to meet environmental requirements, ST offers these devices in different grades of ECOPACK® packages, depending on their level of environmental compliance. ECOPACK® specifications, grade definitions and product status are available at: www.st.com. ECOPACK® is an ST trademark.

4.1 D²PAK (TO-263) type A package information

Figure 22. D²PAK (TO-263) type A package outline

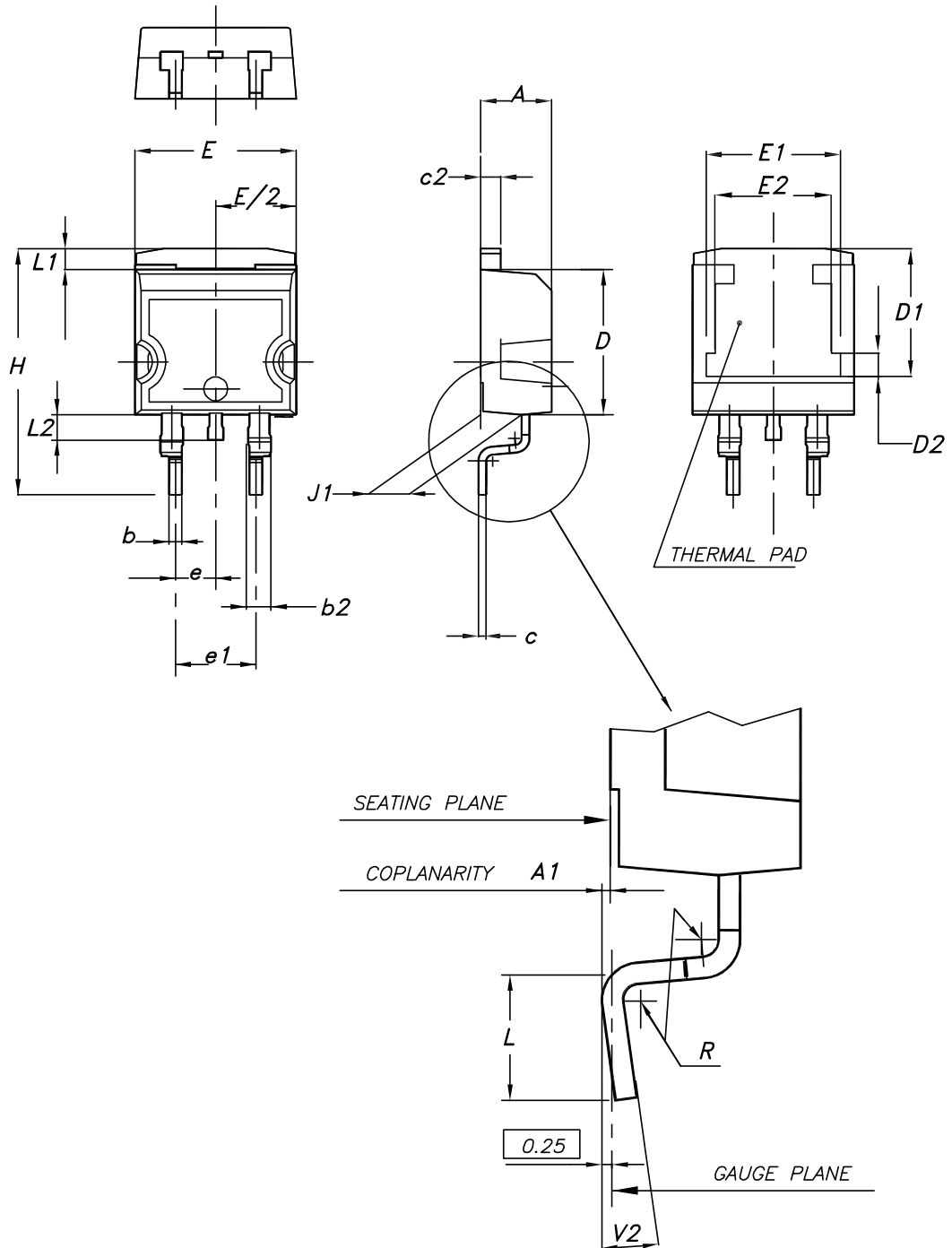

0079457_25

Table 8. D²PAK (TO-263) type A package mechanical data

Dim.	mm		
	Min.	Typ.	Max.
A	4.40		4.60
A1	0.03		0.23
b	0.70		0.93
b2	1.14		1.70
c	0.45		0.60
c2	1.23		1.36
D	8.95		9.35
D1	7.50	7.75	8.00
D2	1.10	1.30	1.50
E	10.00		10.40
E1	8.30	8.50	8.70
E2	6.85	7.05	7.25
e		2.54	
e1	4.88		5.28
H	15.00		15.85
J1	2.49		2.69
L	2.29		2.79
L1	1.27		1.40
L2	1.30		1.75
R		0.40	
V2	0°		8°

Figure 23. D²PAK (TO-263) recommended footprint (dimensions are in mm)

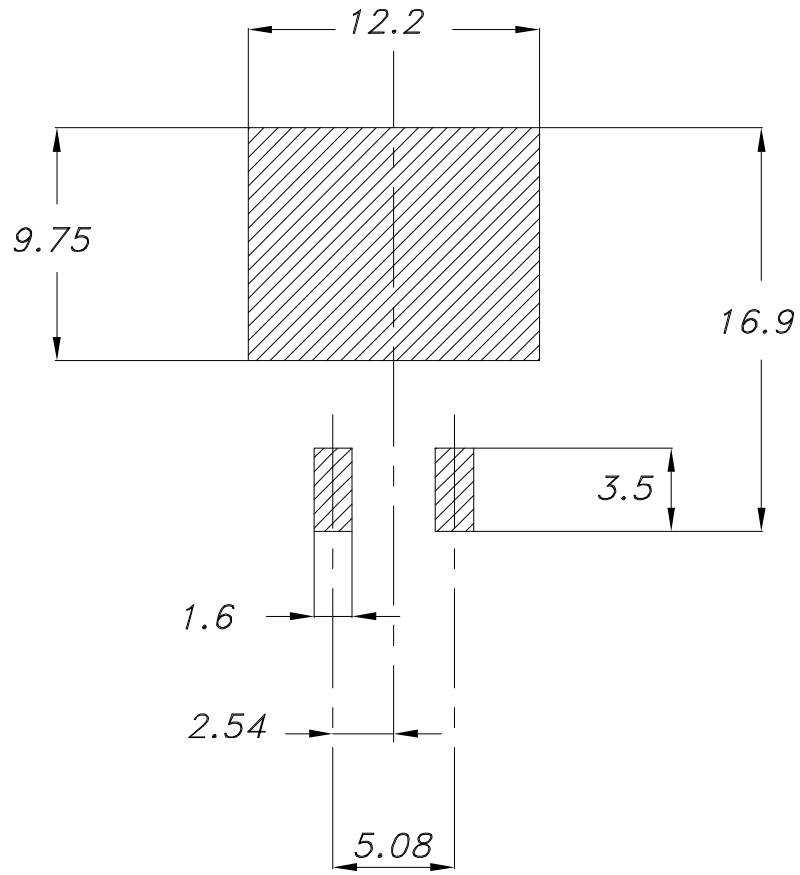

Footprint

4.2 DPAK (TO-252) type A2 package information

Figure 24. DPAK (TO-252) type A2 package outline

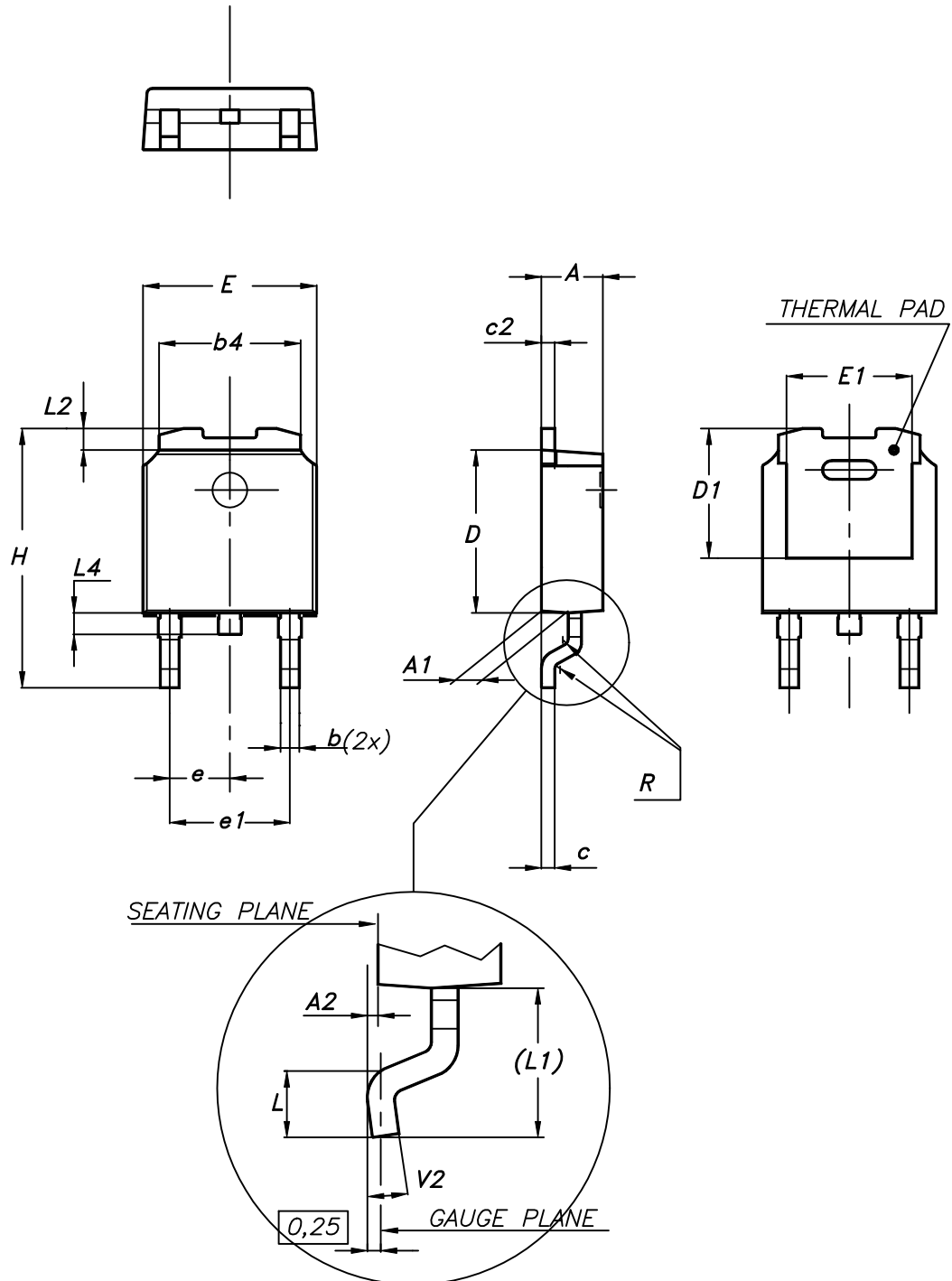

0068772_type-A2_rev25

Table 9. DPAK (TO-252) type A2 mechanical data

Dim.	mm		
	Min.	Typ.	Max.
A	2.20		2.40
A1	0.90		1.10
A2	0.03		0.23
b	0.64		0.90
b4	5.20		5.40
c	0.45		0.60
c2	0.48		0.60
D	6.00		6.20
D1	4.95	5.10	5.25
E	6.40		6.60
E1	5.10	5.20	5.30
e	2.159	2.286	2.413
e1	4.445	4.572	4.699
H	9.35		10.10
L	1.00		1.50
L1	2.60	2.80	3.00
L2	0.65	0.80	0.95
L4	0.60		1.00
R		0.20	
V2	0°		8°

Figure 25. DPAK (TO-252) recommended footprint (dimensions are in mm)

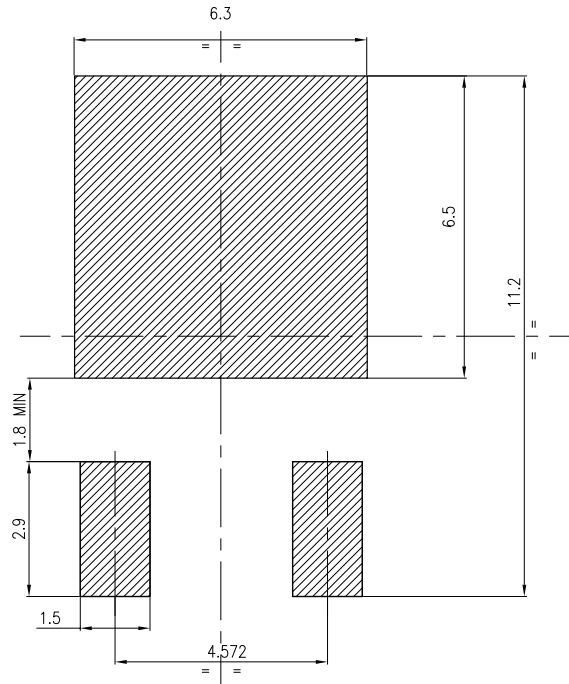

FP_0068772_25

4.3 D²PAK and DPAK packing information

Figure 26. Tape outline

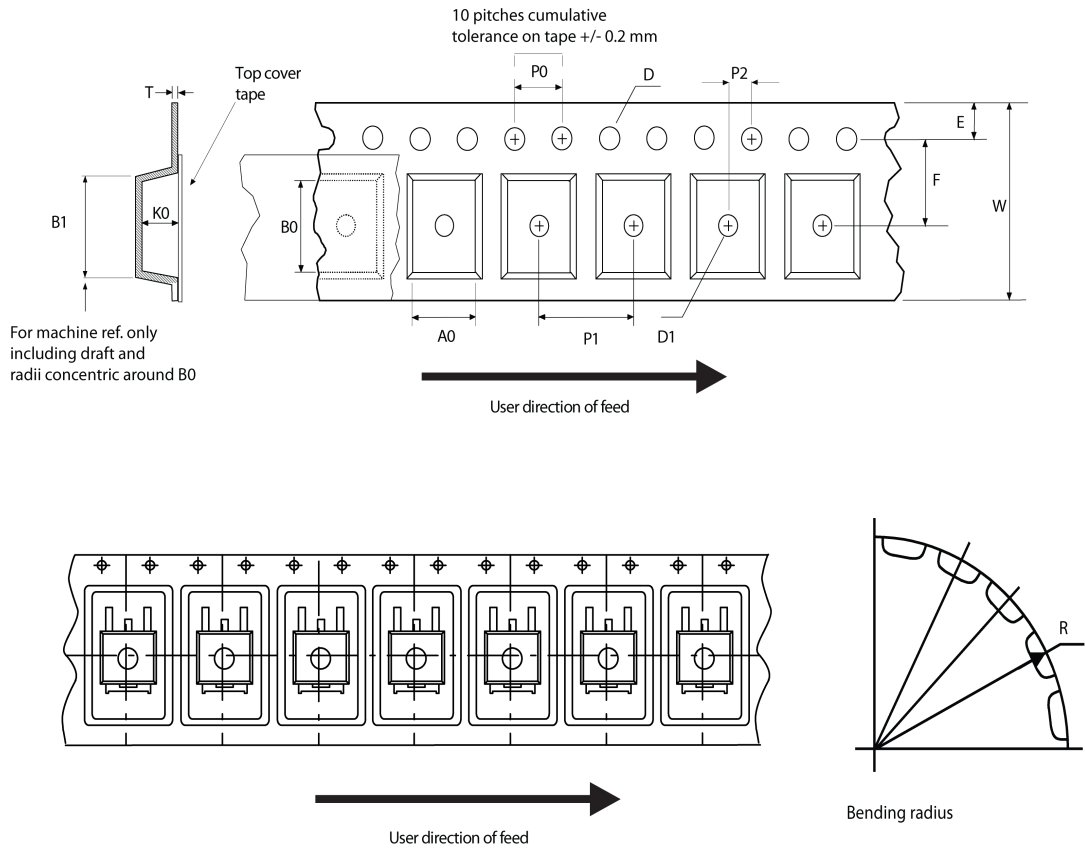

AM08852v1

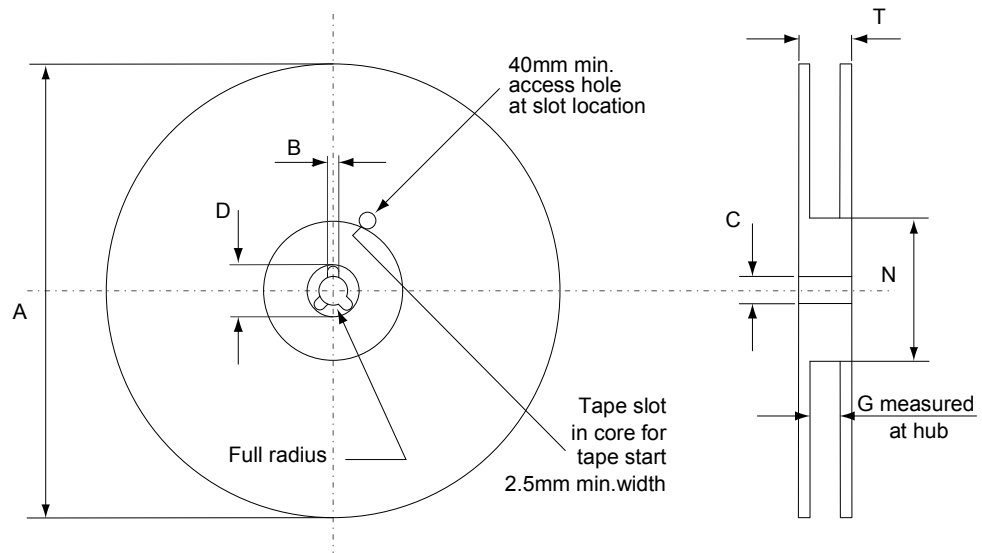
Figure 27. Reel outline

AM06038v1

Table 10. D²PAK tape and reel mechanical data

Tape			Reel		
Dim.	mm		Dim.	mm	
	Min.	Max.		Min.	Max.
A0	10.5	10.7	A		330
B0	15.7	15.9	B	1.5	
D	1.5	1.6	C	12.8	13.2
D1	1.59	1.61	D	20.2	
E	1.65	1.85	G	24.4	26.4
F	11.4	11.6	N	100	
K0	4.8	5.0	T		30.4
P0	3.9	4.1	Base quantity		
P1	11.9	12.1			
P2	1.9	2.1	Bulk quantity		
R	50				
T	0.25	0.35			
W	23.7	24.3			

Table 11. DPAK tape and reel mechanical data

Tape			Reel		
Dim.	mm		Dim.	mm	
	Min.	Max.		Min.	Max.
A0	6.8	7	A		330
B0	10.4	10.6	B	1.5	
B1		12.1	C	12.8	13.2
D	1.5	1.6	D	20.2	
D1	1.5		G	16.4	18.4
E	1.65	1.85	N	50	
F	7.4	7.6	T		22.4
K0	2.55	2.75			
P0	3.9	4.1	Base qty.		2500
P1	7.9	8.1	Bulk qty.		2500
P2	1.9	2.1			
R	40				
T	0.25	0.35			
W	15.7	16.3			

4.4 TO-220FP package information

Figure 28. TO-220FP package outline

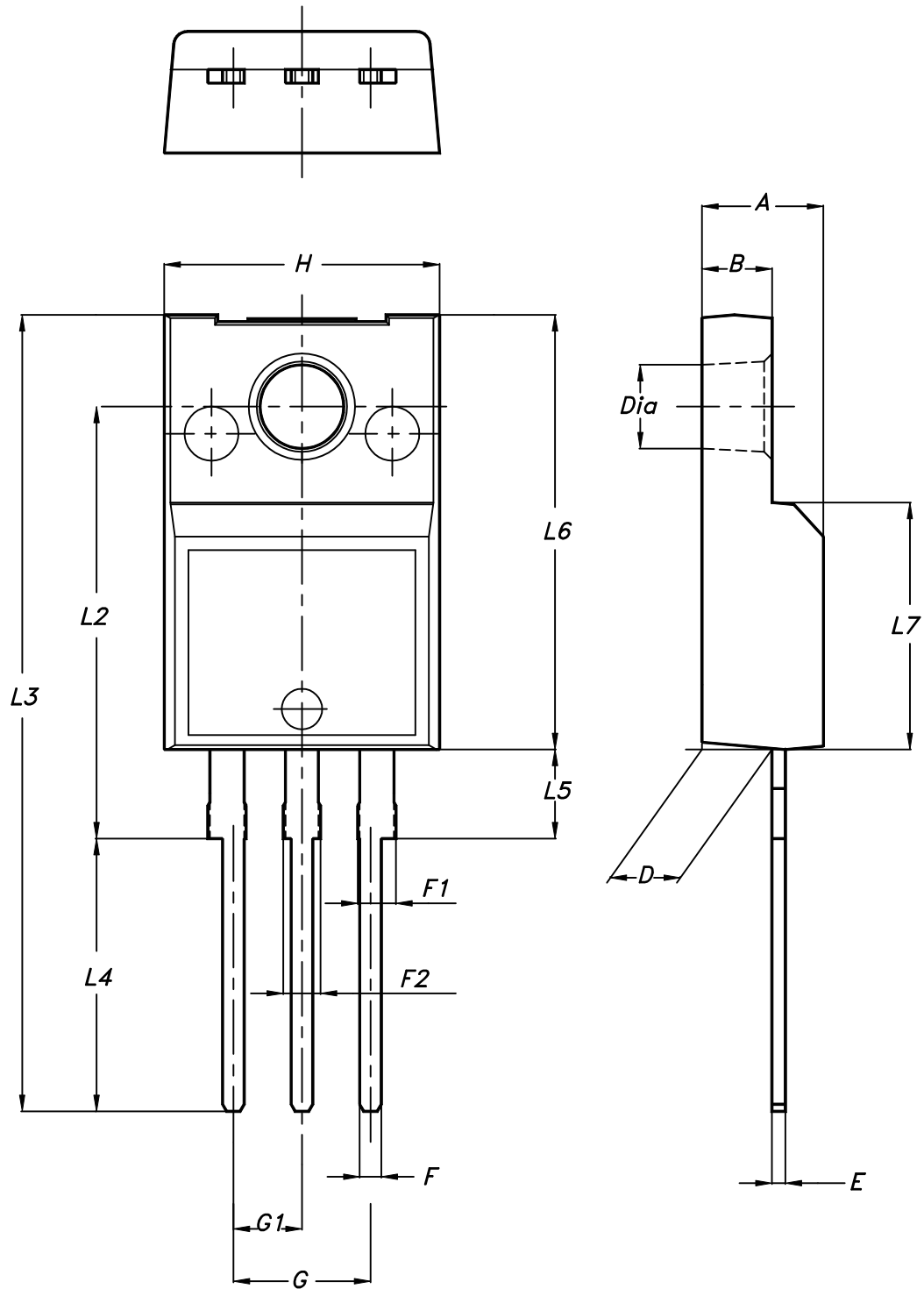

7012510_Rev_12_B

Table 12. TO-220FP package mechanical data

Dim.	mm		
	Min.	Typ.	Max.
A	4.4		4.6
B	2.5		2.7
D	2.5		2.75
E	0.45		0.7
F	0.75		1
F1	1.15		1.70
F2	1.15		1.70
G	4.95		5.2
G1	2.4		2.7
H	10		10.4
L2		16	
L3	28.6		30.6
L4	9.8		10.6
L5	2.9		3.6
L6	15.9		16.4
L7	9		9.3
Dia	3		3.2

4.5 I²PAK package information

Figure 29. I²PAK package outline

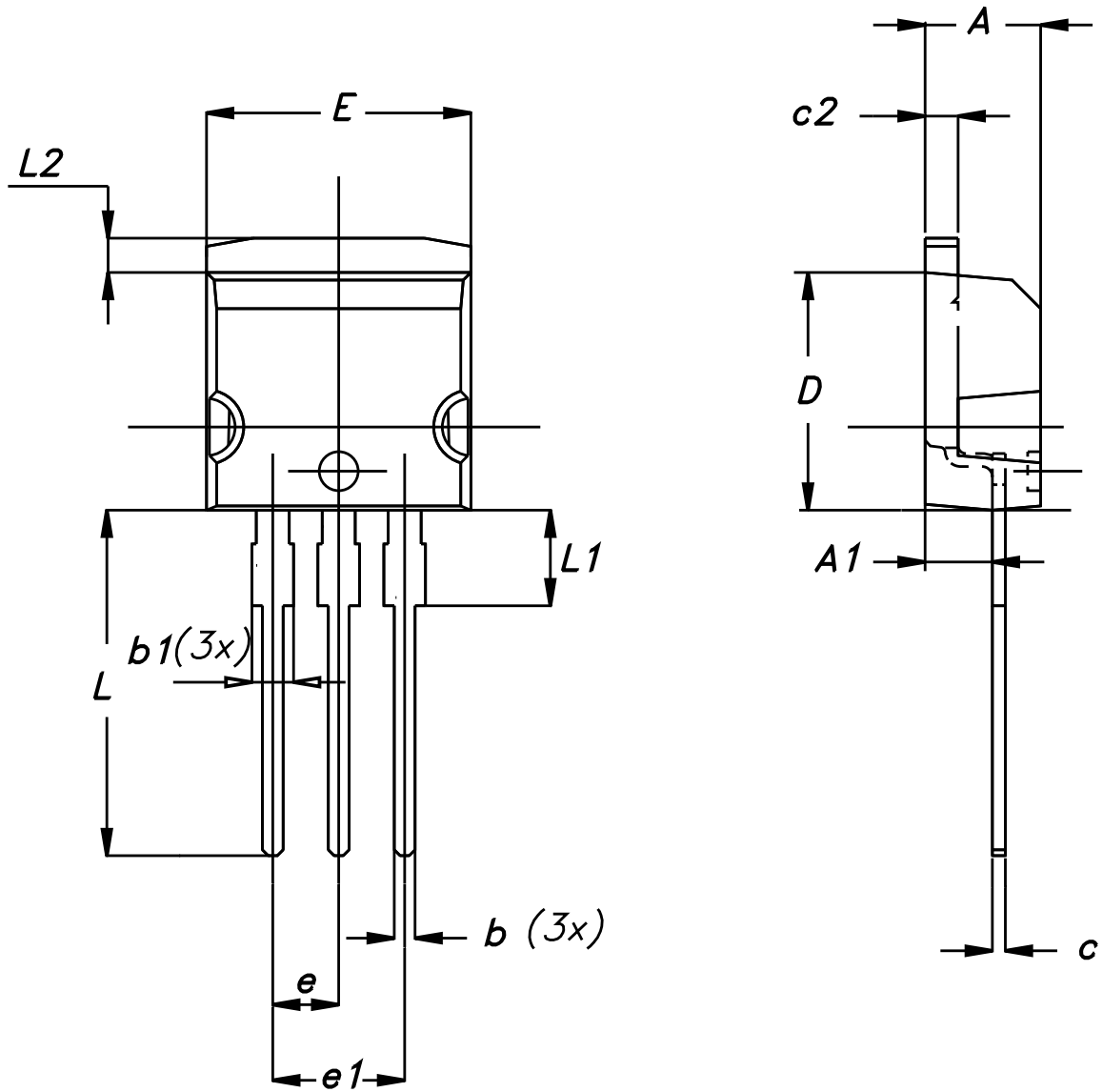

0004982_Rev_H

Table 13. I²PAK package mechanical data

Dim.	mm		
	Min.	Typ.	Max.
A	4.40	-	4.60
A1	2.40	-	2.72
b	0.61	-	0.88
b1	1.14	-	1.70
c	0.49	-	0.70
c2	1.23	-	1.32
D	8.95	-	9.35
e	2.40	-	2.70
e1	4.95	-	5.15
E	10	-	10.40
L	13	-	14
L1	3.50	-	3.93
L2	1.27	-	1.40

4.6 TO-220 type A package information

Figure 30. TO-220 type A package outline

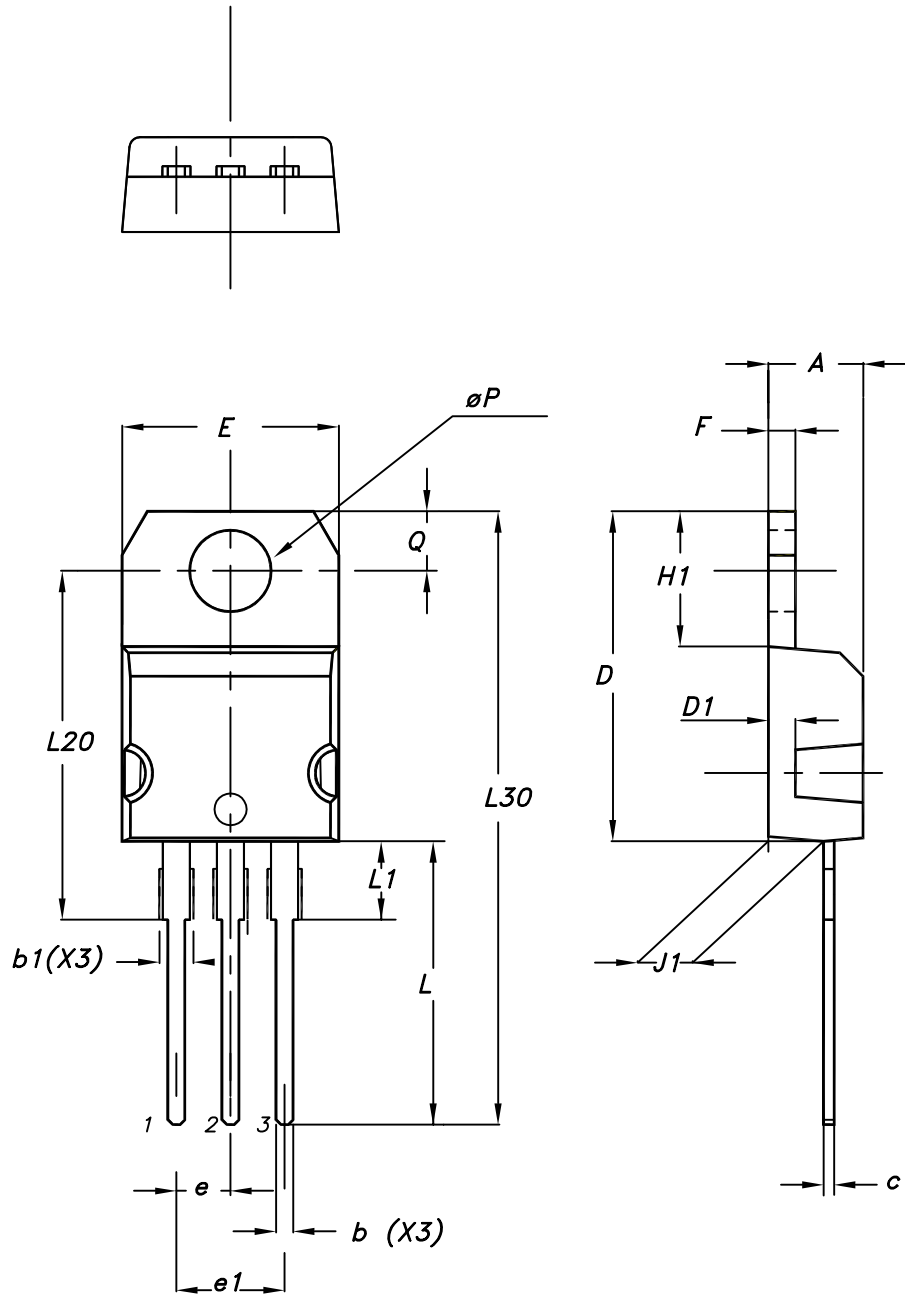

0015988_typeA_Rev_21

Table 14. TO-220 type A package mechanical data

Dim.	mm		
	Min.	Typ.	Max.
A	4.40		4.60
b	0.61		0.88
b1	1.14		1.55
c	0.48		0.70
D	15.25		15.75
D1		1.27	
E	10.00		10.40
e	2.40		2.70
e1	4.95		5.15
F	1.23		1.32
H1	6.20		6.60
J1	2.40		2.72
L	13.00		14.00
L1	3.50		3.93
L20		16.40	
L30		28.90	
øP	3.75		3.85
Q	2.65		2.95

5 Ordering information

Table 15. Order codes

Order code	Marking	Package	Packing
STB100N10F7	100N10F7	D ² PAK	Tape and reel
STD100N10F7		DPAK	Tape and reel
STF100N10F7		TO-220FP	Tube
STI100N10F7		I ² PAK	Tube
STP100N10F7		TO-220	Tube

Revision history

Table 16. Document revision history

Date	Version	Changes
05-Oct-2012	1	Initial release.
07-Feb-2013	2	<p>Inserted device in TO-220FP.</p> <p>Updated title and features on the cover page, <i>Table 1: Device summary</i>, <i>Table 2: Absolute maximum ratings</i>, <i>Table 3: Thermal resistance</i> and <i>Table 5: On/off states</i> accordingly.</p> <p>Updated <i>Table 6: Dynamic</i>, <i>Table 7: Switching times</i>, <i>Table 8: Source drain diode</i> and <i>Section 4: Package mechanical data</i>.</p> <p>Added <i>Section 5: Packaging mechanical data</i>.</p>
29-Apr-2013	3	<p>Modified: the entire typical values in <i>Table 6</i>, <i>t_f</i> typical value in <i>Table 7</i>, VSD and typical values for <i>t_{rr}</i>, <i>q_{rr}</i>, IRRM</p> <p>Inserted: <i>Table 4: Avalanche characteristics</i> and <i>Section 2.1: Electrical characteristics (curves)</i></p> <p>Minor text changes</p>
25-Nov-2013	4	<p>Inserted device in D²PAK.</p> <p>Updated title and features on the cover page, <i>Table 1: Device summary</i>, <i>Table 2: Absolute maximum ratings</i>, <i>Table 3: Thermal resistance</i> and <i>Table 5: On/off states</i> accordingly.</p> <p>Updated <i>Table 6: Dynamic</i>, <i>Section 4: Package mechanical data</i> and <i>Section 5: Packaging mechanical data</i>.</p>
18-Jun-2018	5	<p>Added STI100N10F7 device and updated the document accordingly.</p> <p>Removed maturity status indication, updated title, features and description on cover page.</p> <p>Updated Table 1. Absolute maximum ratings.</p> <p>Updated Section 4 Package information.</p> <p>Minor text changes</p>

Contents

1	Electrical ratings	2
2	Electrical characteristics	3
2.1	Electrical characteristics (curves)	5
3	Test circuits	8
4	Package information	9
4.1	D ² PAK (TO-263) type A package information	9
4.2	DPAK (TO-252) type A2 package information	12
4.3	D ² PAK and DPAK packing information	15
4.4	TO-220FP package information	18
4.5	I ² PAK package information	20
4.6	TO-220 type A package information	22
5	Ordering information	25
	Revision history	26



IMPORTANT NOTICE – PLEASE READ CAREFULLY

STMicroelectronics NV and its subsidiaries (“ST”) reserve the right to make changes, corrections, enhancements, modifications, and improvements to ST products and/or to this document at any time without notice. Purchasers should obtain the latest relevant information on ST products before placing orders. ST products are sold pursuant to ST’s terms and conditions of sale in place at the time of order acknowledgement.

Purchasers are solely responsible for the choice, selection, and use of ST products and ST assumes no liability for application assistance or the design of Purchasers’ products.

No license, express or implied, to any intellectual property right is granted by ST herein.

Resale of ST products with provisions different from the information set forth herein shall void any warranty granted by ST for such product.



ST and the ST logo are trademarks of ST. All other product or service names are the property of their respective owners.

Information in this document supersedes and replaces information previously supplied in any prior versions of this document.

© 2018 STMicroelectronics – All rights reserved

Looking for pricing, stock, or lifecycle information?

Click below to explore more details on WIN SOURCE:

-  [View STD100N10F7 on WIN SOURCE](#)
-  [STMicroelectronics Information](#)

Optimize Your Supply Chain with WIN SOURCE Solutions

-  Global Sourcing Solution
-  Obsolete Management
-  Cost Control Management
-  Shortage Management
-  Alternative Solution
-  Excess Inventory Management