



# THE DATASHEET OF CM6300



# CM6300

## EMI Filters with ESD Protection for SIM Card Applications

### Product Description

The CM6300 is a 3 x 3, 8-bump EMI filter with ESD protection device for SIM card applications in 0.5 mm pitch CSP form factor. It is fully compliant with IEC 61000-4-2. The CM6300 is RoHS II compliant.

**Table 1. PIN DESCRIPTIONS**

8-bump CSP Package	
Pin	Description
A2	Channel 1 External
A3	Channel 1 Internal
B1	Channel 2 External
B2	GND
B3	Channel 2 Internal
C1	Channel 3 External
C2	V External
C3	Channel 3 Internal



**ON Semiconductor®**

<http://onsemi.com>



WLCSP8  
CASE 567CD

### MARKING DIAGRAM

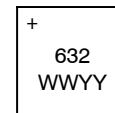

632 = CM6300  
WWYY = Date Code

### PACKAGE / PINOUT DIAGRAMS

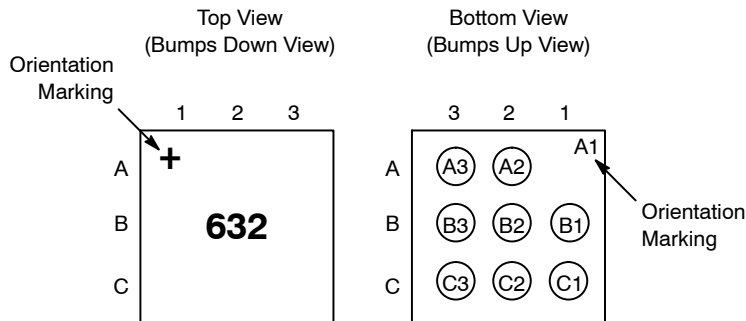

### ELECTRICAL SCHEMATIC

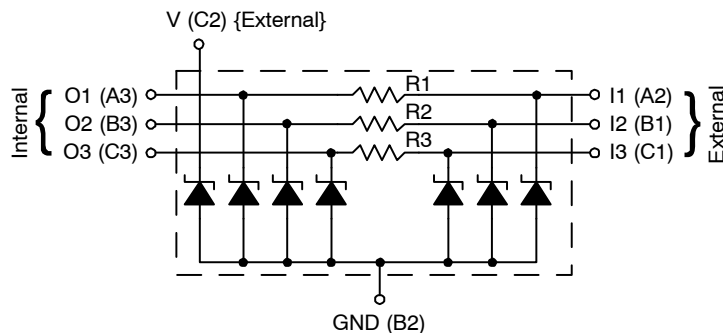

### ORDERING INFORMATION

Device	Package	Shipping†
CM6300	CSP-8 (Pb-Free)	5000/Tape & Reel

†For information on tape and reel specifications, including part orientation and tape sizes, please refer to our Tape and Reel Packaging Specification Brochure, BRD8011/D.

# CM6300

## ELECTRICAL SPECIFICATIONS AND CONDITIONS

**Table 2. PARAMETERS AND OPERATING CONDITIONS**

Parameter	Rating	Units
Storage Temperature Range	-55 to +150	°C
Operating Temperature Range	-40 to +85	°C

**Table 3. ELECTRICAL OPERATING CHARACTERISTICS** (Note 1)

Symbol	Parameter	Conditions	Min	Typ	Max	Units
R <sub>1</sub>	Resistance		80	100	120	Ω
R <sub>2</sub>	Resistance		37.6	47	56.4	Ω
R <sub>3</sub>	Resistance		80	100	120	Ω
C	Capacitance on filter channels 1, 2 and 3	At 1 MHz, V <sub>IN</sub> = 0 V	13.4	16.7	20	pF
	Capacitance on clamp channel (pin C2)	At 1 MHz, V <sub>IN</sub> = 0 V	8.2	10.3	12.4	pF
V <sub>B</sub>	Breakdown Voltage (Positive)	I <sub>F</sub> = 8 mA	6	6.8	20	V
V <sub>ESD</sub>	ESD Protection Peak Discharge Voltage at A2, B1 and C1 pins a) Contact Discharge per IEC 61000-4-2 standard b) Air Discharge per IEC 61000-4-2 standard	(Note 2)	±15 ±15			kV
	ESD Protection Peak Discharge Voltage at C2 pin a) Contact Discharge per IEC 61000-4-2 standard b) Air Discharge per IEC 61000-4-2 standard	(Note 2)	±15 ±15			kV
	ESD Protection Peak Discharge Voltage at A3, B3 and C3 pins a) Contact Discharge per IEC 61000-4-2 standard b) Air Discharge per IEC 61000-4-2 standard	(Note 2)	±4 ±4			kV

- All parameters specified at T<sub>A</sub> = 25°C unless otherwise noted.
- Standard IEC 61000-4-2 with C<sub>Discharge</sub> = 150 pF, R<sub>Discharge</sub> = 330 Ω.

## MECHANICAL SPECIFICATION

**Table 4. VERTICAL STRUCTURE DIMENSIONS** (nominal)

Ref.	Parameter	Material	Dimension
a	Die Thickness	Silicon	396 μm
h	Repassivation	Polyimide	10 μm
d	UBM-(Ti/Cu)	Plated Cu	5.0 μm
		Sputtered Cu	0.4 μm
		Sputtered Ti	0.1 μm
e	UBM Wetting Area Diameter		280 μm
b	Bump Standoff		240 μm
f	Solder Bump Diameter after Bump Reflow		320 μm
c	Metal Pad Height	AlSiCu	1.5 μm
g	Metal Pad Diameter		60 μm
D1	Finished Thickness		0.650 mm
D2			0.406 mm

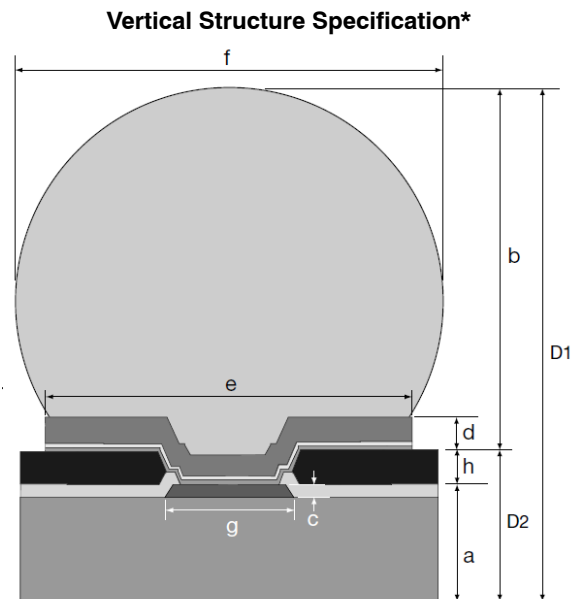

**Figure 1. Sectional View**

\* Daisy Chain CM6020

# CM6300

## RF CHARACTERISTICS

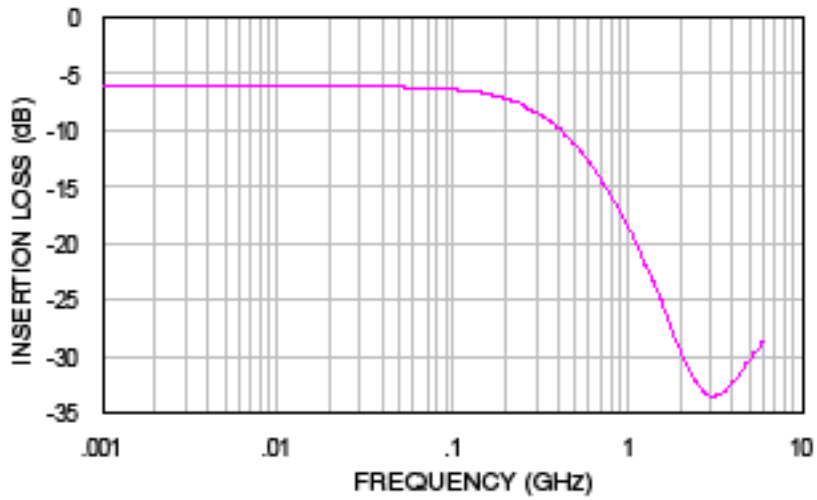

Figure 2. Insertion Loss, Filter 1 (pins A2, A3) and Filter 3 (pins C1, C3) (Bias = 0 V,  $T_A = 25^\circ\text{C}$ )

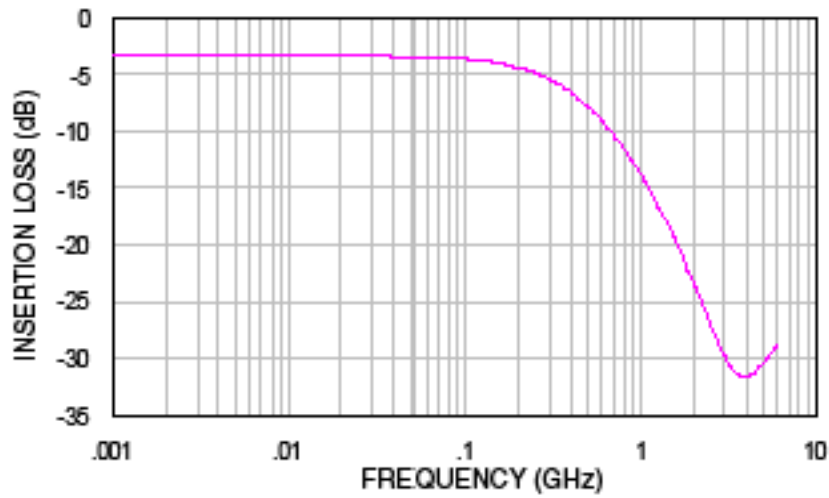
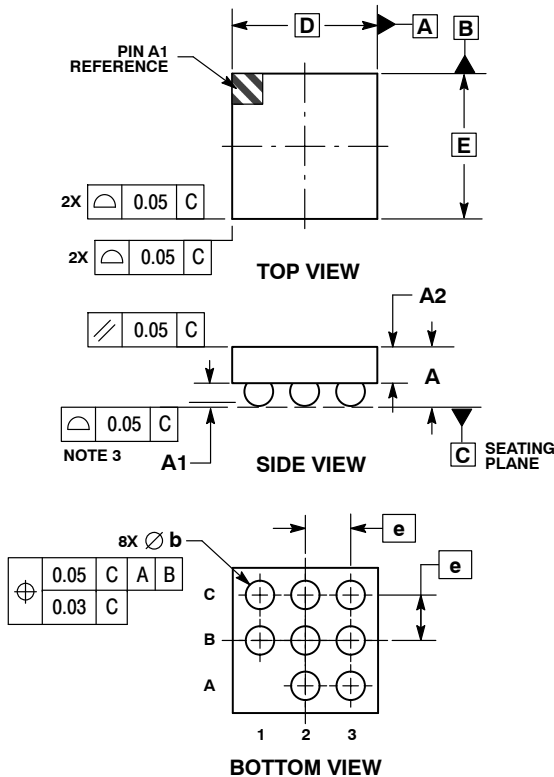

Figure 3. Insertion Loss, Filter 2 (pins B1, B3) (Bias = 0 V,  $T_A = 25^\circ\text{C}$ )

# CM6300

## PACKAGE DIMENSIONS

WLCSP8, 1.6x1.6  
CASE 567CD-01  
ISSUE O



**NOTES:**

1. DIMENSIONING AND TOLERANCING PER ASME Y14.5M, 1994.
2. CONTROLLING DIMENSION: MILLIMETERS.
3. COPLANARITY APPLIES TO SPHERICAL CROWNS OF SOLDER BALLS.

DIM	MILLIMETERS	
	MIN	MAX
A	0.61	0.69
A1	0.21	0.27
A2	0.41 REF	
b	0.29	0.34
D	1.60 BSC	
E	1.60 BSC	
e	0.50 BSC	

**RECOMMENDED SOLDERING FOOTPRINT\***

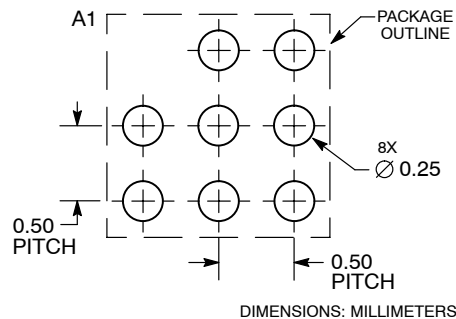

\*For additional information on our Pb-Free strategy and soldering details, please download the ON Semiconductor Soldering and Mounting Techniques Reference Manual, SOLDERRM/D.

ON Semiconductor and are registered trademarks of Semiconductor Components Industries, LLC (SCILLC). SCILLC reserves the right to make changes without further notice to any products herein. SCILLC makes no warranty, representation or guarantee regarding the suitability of its products for any particular purpose, nor does SCILLC assume any liability arising out of the application or use of any product or circuit, and specifically disclaims any and all liability, including without limitation special, consequential or incidental damages. "Typical" parameters which may be provided in SCILLC data sheets and/or specifications can and do vary in different applications and actual performance may vary over time. All operating parameters, including "Typicals" must be validated for each customer application by customer's technical experts. SCILLC does not convey any license under its patent rights nor the rights of others. SCILLC products are not designed, intended, or authorized for use as components in systems intended for surgical implant into the body, or other applications intended to support or sustain life, or for any other application in which the failure of the SCILLC product could create a situation where personal injury or death may occur. Should Buyer purchase or use SCILLC products for any such unintended or unauthorized application, Buyer shall indemnify and hold SCILLC and its officers, employees, subsidiaries, affiliates, and distributors harmless against all claims, costs, damages, and expenses, and reasonable attorney fees arising out of, directly or indirectly, any claim of personal injury or death associated with such unintended or unauthorized use, even if such claim alleges that SCILLC was negligent regarding the design or manufacture of the part. SCILLC is an Equal Opportunity/Affirmative Action Employer. This literature is subject to all applicable copyright laws and is not for resale in any manner.

**PUBLICATION ORDERING INFORMATION**



**LITERATURE FULFILLMENT:**  
Literature Distribution Center for ON Semiconductor  
P.O. Box 5163, Denver, Colorado 80217 USA  
**Phone:** 303-675-2175 or 800-344-3860 Toll Free USA/Canada  
**Fax:** 303-675-2176 or 800-344-3867 Toll Free USA/Canada  
**Email:** orderlit@onsemi.com

**N. American Technical Support:** 800-282-9855 Toll Free USA/Canada  
**Europe, Middle East and Africa Technical Support:**  
Phone: 421 33 790 2910  
**Japan Customer Focus Center**  
Phone: 81-3-5773-3850



**ON Semiconductor Website:** [www.onsemi.com](http://www.onsemi.com)  
**Order Literature:** <http://www.onsemi.com/orderlit>  
For additional information, please contact your local Sales Representative

## Looking for pricing, stock, or lifecycle information?

Click below to explore more details on WIN SOURCE:

-  [View CM6300](#) on WIN SOURCE
-  [ON Semiconductor](#) Information

## Optimize Your Supply Chain with WIN SOURCE Solutions

-  Global Sourcing Solution
-  Obsolete Management
-  Cost Control Management
-  Shortage Management
-  Alternative Solution
-  Excess Inventory Management