



# THE DATASHEET OF OMH3020B



# High Reliability Hallogtic® Hall-Effect Sensors



OMH090, OMH3019, OMH3020, OMH3040, OMH3075, OMH3131 (B, S versions)



Ceramic Package

## Features:

- Designed for non-contact switching operations
- Operates over a broad range of supply voltages
- Excellent temperature stability operates in harsh environments
- Suitable for military and space applications
- Processing patterned after class B or S of MIL-STD-883
- Through Hole 0.40" [10.16 mm] lead length minimum
- ESD Rating of Class 3B per MIL-STD-883G, M3015.7, HB model.

## Description:

These Hall-effect devices contain a monolithic integrated circuit which incorporates a Hall element, a linear amplifier, a threshold amplifier, and Schmitt trigger on a single Hallogtic® silicon chip. Included on-chip is a band-gap voltage regulator that allows operation with a wide range of supply voltages. These devices feature logic level output and provide up to 21 mA of sink current. This allows direct driving of more than 7 TTL loads or any standard logic family using power supplies ranging from 4.5 to 24 volts. Output amplitude is constant at switching frequencies from DC to over 200 kHz.

The **Uni-Polar** turns on with a (logic level "0") after a sufficient magnetic field from the south pole of a magnet approaches the symbolized face of the device (operating point) and turns off (logic level "1") after the magnetic field reaches a minimum value. The **Bi-Polar** device turns on (logic level "0") in the presence of a magnetic south pole and turns off (logic level "1") when subjected to a magnetic north pole. Both magnetic poles are necessary for operation for Bi-Polar devices. This feature makes these sensors ideal for applications in non-contact switching operations, brushless DC motors and for use with multiple pole magnets.

B and S devices are processed to OPTEK's military screening program patterned after MIL-STD-883. This product has passed Radiation Hardness testing up to 350 Krad (si) per MIL-STD-883 method 1019.6 and up to 150 Krad (si) for ELDRS.

Contact your local representative or OPTEK for more information.

## Applications:

- Non-contact switching operations
- Brushless DC motors
- Multiple pole magnets

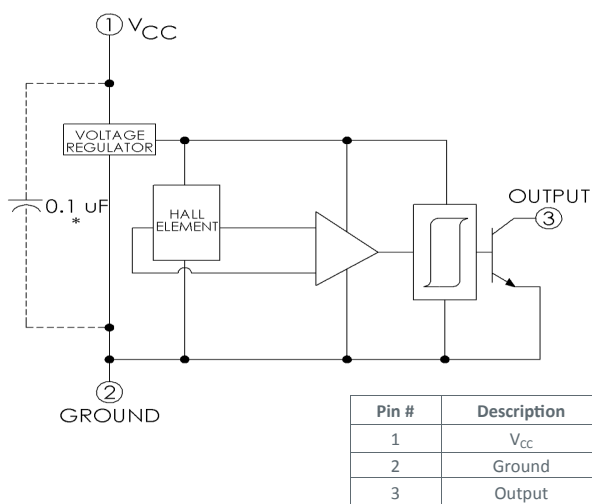

\* Add capacitor for stable operation

Lead finish = Solder Dipped (Sn 63/37)

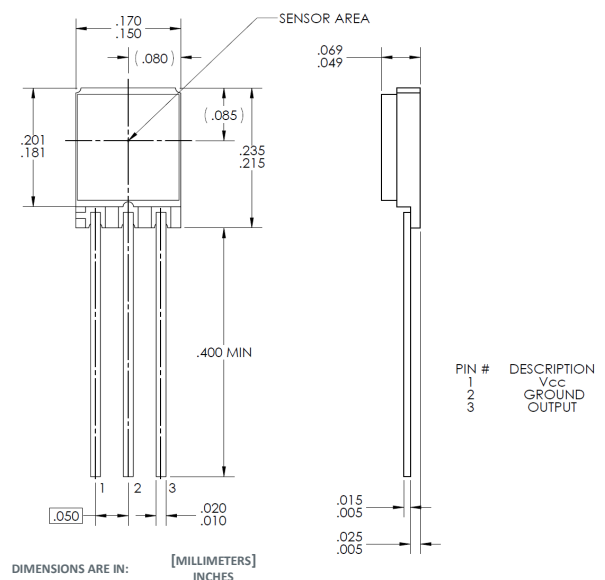

## General Note

TT Electronics reserves the right to make changes in product specification without notice or liability. All information is subject to TT Electronics' own data and is considered accurate at time of going to print.

OPTEK Technology, Inc.  
1645 Wallace Drive, Carrollton, TX 75006 | Ph: +1 972 323 2200  
www.optekinc.com | www.ttelectronics.com

# High Reliability Halloglic® Hall-Effect Sensors



OMH090, OMH3019, OMH3020, OMH3040,  
OMH3075, OMH3131 (B, S versions)

## Absolute Maximum Ratings ( $T_A = 25^\circ\text{C}$ unless otherwise noted)

Supply Voltage, $V_{CC}$	25 V
Storage Temperature Range, $T_S$	-65°C to +150°C
Operating Temperature Range, $T_A$	-55°C to +150°C
Lead Soldering Temperature (1/8 in. (3.2 mm) from case for 5 seconds with soldering iron)	260°C <sup>(1)</sup>
Output ON Current, $I_{SINK}$	25 mA
Output OFF Voltage, $V_{OUT}$	25 V
Magnetic Flux Density, B	Unlimited

### Notes:

(1) Heat sink leads during hand soldering.

Part Number	Hi-Reliability Halloglic® Sensor	Operate Point Gauss Min / Typ / Max	Release Point Gauss Min / Typ / Max	Hysteresis Gauss Min / Typ / Max	$V_{CC}$ (Volts) Min / Max	Package
OMH090B	Uni-Polar Non-Latching	50/90/180	30 / 65 / 160	10 / 30 / 60	4.5 / 24.0	Through Hole
OMH090S						
OMH3019B						
OMH3019S		175 / 300 / 500	125 / 235 / 420	30 / 100 / 155		
OMH3020B		70 / 220 / 350	50 / 180 / 330	15 / 55 / 200		
OMH3020S						
OMH3040B		70 / 150 / 200	50 / 115 / 180	10 / 35 / 60		
OMH3040S						
OMH3131B						
OMH3131S		20 / 60 / 95	10 / 45 / 85	5 / 15 / 40		
OMH3075B	Bi-Polar Latching	50 / 150 / 250	-250 / -150 / -50	100 / 250 / 500		
OMH3075S						

### General Note

TT Electronics reserves the right to make changes in product specification without notice or liability. All information is subject to TT Electronics' own data and is considered accurate at time of going to print.

OPTEK Technology, Inc.  
1645 Wallace Drive, Carrollton, TX 75006 | Ph: +1 972 323 2200  
www.optekinc.com | www.ttelectronics.com

# High Reliability Halloglic® Hall-Effect Sensors



OMH090, OMH3019, OMH3020, OMH3040,  
OMH3075, OMH3131 (B, S versions)

## Electrical Characteristics ( $V_{CC} = 4.5\text{ V to }24\text{ V}$ , $T_A = 25^\circ\text{ C}$ unless otherwise noted) OMH090, OMH090B, OMH090S Uni-Polar

SYMBOL	PARAMETER	MIN	TYP	MAX	UNITS	TEST CONDITIONS
$B_{OP}$	Magnetic Operate Point <sup>(1)</sup>	45 50 20	- 90 -	210 180 180	Gauss	-55°C +25°C +125°C
$B_{RP}$	Magnetic Release Point	25 30 25	- 65 -	150 160 140	Gauss	-55°C +25°C +125°C
$B_H$	Magnetic Hysteresis	5 10	- 30	95 60	Gauss	-55°C +25°C & +125°C
$I_{CC}$	Supply Current	- - -	- 5 -	9 11 5	mA	-55°C, $V_{CC} = 24\text{ V}$ , Output On, $B \geq 250\text{ Gauss}$ +25° +125°C
$V_{OL}$	Output Saturation Voltage	- -	- 125	300 400	mV	-55°C, $V_{CC} = 4.5\text{ V}$ , $I_{OL} = 30\text{ mA}$ , $B \geq 250\text{ Gauss}$ +25°C & +125°C
$I_{OH}$	Output Leakage Current	- - -	- 0.50 -	10 11 12	μA	-55°C, $V_{CC} = 24\text{ V}$ , $V_{OUT} = 24\text{ V}$ , $B \leq 250\text{ Gauss}$ +25° +125°C
$t_r$	Output Rise Time	-	0.13	1.00	μs	$R_L = 820\ \Omega$ , $C_L = 20\text{ pF}$ , $V_{CC} = 14\text{ V}$ (guaranteed not tested)
$t_f$	Output Fall Time	-	0.14	1.00	μs	

## Electrical Characteristics ( $V_{CC} = 4.5\text{ V to }24\text{ V}$ , $T_A = 25^\circ\text{ C}$ unless otherwise noted) OMH3019, OMH3019B, OMH3019S Uni-Polar

SYMBOL	PARAMETER	MIN	TYP	MAX	UNITS	TEST CONDITIONS
$B_{OP}$	Magnetic Operate Point <sup>(1)</sup>	175 -	300 -	500 575	Gauss	+25°C -55°C & +125°C
$B_{RP}$	Magnetic Release Point	125 100	235 -	420 -	Gauss	+25°C -55°C & +125°C
$B_H$	Magnetic Hysteresis	30 20	100 -	155 -	Gauss	+25°C -55°C to +125°C
$I_{CC}$	Supply Current	-	5	9	mA	$V_{CC} = 24\text{ V}$ , Output On, $B \leq 50\text{ Gauss}$
$V_{OL}$	Output Saturation Voltage	-	125	300	mV	$V_{CC} = 4.5\text{ V}$ , $I_{OL} = 15\text{ mA}$ , $B \geq 500\text{ Gauss}$
$I_{OH}$	Output Leakage Current	-	0.10	1.0	μA	$V_{CC} = 24\text{ V}$ , $V_{OUT} = 24\text{ V}$ , $B < 50\text{ Gauss}$
$t_r$	Output Rise Time	-	0.13	1	μs	$R_L = 460\ \Omega$ , $C_L = 20\text{ pF}$ , $V_{CC} = 12\text{ V}$ (guaranteed not tested)
$t_f$	Output Fall Time	-	0.14	1	μs	

Notes:

(1) South pole facing symbolized surface.

### General Note

TT Electronics reserves the right to make changes in product specification without notice or liability. All information is subject to TT Electronics' own data and is considered accurate at time of going to print.

OPTEK Technology, Inc.  
1645 Wallace Drive, Carrollton, TX 75006 | Ph: +1 972 323 2200  
www.optekinc.com | www.ttelectronics.com

# High Reliability Hallogtic® Hall-Effect Sensors



OMH090, OMH3019, OMH3020, OMH3040,  
OMH3075, OMH3131 (B, S versions)

## Electrical Characteristics ( $V_{CC} = 4.5\text{ V to }24\text{ V}$ , $T_A = 25^\circ\text{ C}$ unless otherwise noted)

### OMH3020, OMH3020B, OMH3020S Uni-Polar

SYMBOL	PARAMETER	MIN	TYP	MAX	UNITS	TEST CONDITIONS
$B_{OP}$	Magnetic Operate Point <sup>(1)</sup>	70 -	220 -	350 425	Gauss	+25°C -55°C & +125°C
$B_{RP}$	Magnetic Release Point	50 25	180 -	330 -	Gauss	+25°C -55°C & +125°C
$B_H$	Magnetic Hysteresis	15 10	55 -	200 -	Gauss	+25°C -55°C & +125°C
$I_{CC}$	Supply Current	-	4	7	mA	$V_{CC} = 24\text{ V}$ , Output On, $B \leq 50\text{ Gauss}$
$V_{OL}$	Output Saturation Voltage	-	100	400	mV	$V_{CC} = 4.5\text{ V}$ , $I_{OL} = 15\text{ mA}$ , $B \geq 350\text{ Gauss}$
$I_{OH}$	Output Leakage Current	-	0.10	10	$\mu\text{A}$	$V_{CC} = 24\text{ V}$ , $V_{OUT} = 24\text{ V}$ , $B \leq 50\text{ Gauss}$
$t_r$	Output Rise Time	-	0.21	1	$\mu\text{s}$	$R_L = 820\ \Omega$ , $C_L = 20\text{ pF}$ , $V_{CC} = 12\text{ V}$ (guaranteed not tested)
$t_f$	Output Fall Time	-	0.10	1	$\mu\text{s}$	

## Electrical Characteristics ( $V_{CC} = 4.5\text{ V to }24\text{ V}$ , $T_A = 25^\circ\text{ C}$ unless otherwise noted)

### OMH3040, OMH3040B, OMH3040S Uni-Polar

SYMBOL	PARAMETER	MIN	TYP	MAX	UNITS	TEST CONDITIONS
$B_{OP}$	Magnetic Operate Point <sup>(1)</sup>	70 75	150 -	200 270	Gauss	+25°C -55°C & +125°C
$B_{RP}$	Magnetic Release Point	50 25	115 -	180 210	Gauss	+25°C -55°C & +125°C
$B_H$	Magnetic Hysteresis	10 20	35 -	60 -	Gauss	+25°C -55°C & +125°C
$I_{CC}$	Supply Current	- -	4 -	8 8 10	mA	+25°C, $V_{CC} = 24\text{ V}$ , Output On, $B \geq 300\text{ Gauss}$ +125°C -55°C
$V_{OL}$	Output Saturation Voltage	-	100	400	mV	$V_{CC} = 4.5\text{ V}$ , $I_{OL} = 20\text{ mA}$ , $B \geq 250\text{ Gauss}$
$I_{OH}$	Output Leakage Current	- - -	- 0.10 -	11 10 12	$\mu\text{A}$	-55°C, $V_{CC} = 24\text{ V}$ , $V_{OUT} = 24\text{ V}$ , $B \leq 75\text{ Gauss}$ +25°C, $V_{CC} = 24\text{ V}$ , $V_{OUT} = 24\text{ V}$ , $B \leq 100\text{ Gauss}$ +125°C, $V_{CC} = 24\text{ V}$ , $V_{OUT} = 24\text{ V}$ , $B \leq 75\text{ G}$
$t_r$	Output Rise Time	-	0.21	1	$\mu\text{s}$	$R_L = 820\ \Omega$ , $C_L = 20\text{ pF}$ , $V_{CC} = 12\text{ V}$ (guaranteed not tested)
Notes: $t_f$	Output Fall Time	-	0.10	1	$\mu\text{s}$	

(1) South pole facing symbolized surface.

#### General Note

TT Electronics reserves the right to make changes in product specification without notice or liability. All information is subject to TT Electronics' own data and is considered accurate at time of going to print.

OPTEK Technology, Inc.  
1645 Wallace Drive, Carrollton, TX 75006 | Ph: +1 972 323 2200  
www.optekinc.com | www.ttelectronics.com

# High Reliability Hallogig® Hall-Effect Sensors



OMH090, OMH3019, OMH3020, OMH3040,  
OMH3075, OMH3131 (B, S versions)

## Electrical Characteristics ( $V_{CC} = 4.5\text{ V to }24\text{ V}$ , $T_A = 25^\circ\text{ C}$ unless otherwise noted) OMH3075, OMH3075B, OMH3075S Bi-Polar Latching

SYMBOL	PARAMETER	MIN	TYP	MAX	UNITS	TEST CONDITIONS
$B_{OP}$	Magnetic Operate Point <sup>(1)</sup>	50 25	150 -	250 275	Gauss	+25°C -55°C & +125°C
$B_{RP}$	Magnetic Release Point	-250 -275	-150 -	-50 -25	Gauss	+25°C -55°C & +125°C
$B_H$	Magnetic Hysteresis	100 50	250 -	500 -	Gauss	+25°C -55°C & +125°C
$I_{CC}$	Supply Current	- -	4 -	8 8 10	mA	+25°C, $V_{CC} = 24\text{ V}$ , (Output On), $B \geq -250\text{ Gauss}$ +125°C -55°C
$V_{OL}$	Output Saturation Voltage	- - -	- 100 -	500 400 400	mV	-55°C +25°C, $V_{CC} = 4.5\text{ V}$ , $I_{OL} = 20\text{ mA}$ , $B \geq 250\text{ Gauss}$ +125°C
$I_{OH}$	Output Leakage Current	-	0.10	1.0	μA	$V_{CC} = 24\text{ V}$ , $V_{OUT} = 24\text{ V}$ , $B \leq -250\text{ Gauss}$
$t_r$	Output Rise Time	-	0.21	1	μs	$R_L = 820\ \Omega$ , $C_L = 20\text{ pF}$ , $V_{CC} = 12\text{ V}$ (guaranteed not tested)
$t_f$	Output Fall Time	-	0.10	1	μs	

## Electrical Characteristics ( $V_{CC} = 4.5\text{ V to }24\text{ V}$ , $T_A = 25^\circ\text{ C}$ unless otherwise noted) OMH3131, OMH3131B & OMH3131S Uni-Polar

SYMBOL	PARAMETER	MIN	TYP	MAX	UNITS	TEST CONDITIONS
$B_{OP}$	Magnetic Operate Point <sup>(1)</sup>	20 10	60 -	95 150	Gauss	+25°C -55°C to +125°C
$B_{RP}$	Magnetic Release Point	10 5	45 -	85 145	Gauss	+25°C -55°C to +125°C
$B_H$	Magnetic Hysteresis	5 5	15 -	40 145	Gauss	+25°C -55°C to +125°C
$I_{CC}$	Supply Current	-	4	7	mA	$V_{CC} = 24\text{ V}$ , Output On, $B > 250\text{ Gauss}$
$V_{OL}$	Output Saturation Voltage	-	100	400	mV	$V_{CC} = 4.5\text{ V}$ , $I_{OL} = 15\text{ mA}$ , $B \geq 250\text{ Gauss}$
$I_{OH}$	Output Leakage Current	-	0.10	10	μA	$V_{CC} = 24\text{ V}$ , $V_{OUT} = 24\text{ V}$ , $B \leq 0\text{ Gauss}$
$t_r$	Output Rise Time	-	0.21	1	μs	$R_L = 820\ \Omega$ , $C_L = 20\text{ pF}$ , $V_{CC} = 12\text{ V}$ (guaranteed not tested)
$t_f$	Output Fall Time	-	0.10	1	μs	

Notes:

(1) South pole facing symbolized surface.

### General Note

TT Electronics reserves the right to make changes in product specification without notice or liability. All information is subject to TT Electronics' own data and is considered accurate at time of going to print.

OPTEK Technology, Inc.  
1645 Wallace Drive, Carrollton, TX 75006 | Ph: +1 972 323 2200  
www.optekinc.com | www.ttelectronics.com

# High Reliability Halloglic® Hall-Effect Sensors



OMH090, OMH3019, OMH3020, OMH3040,  
OMH3075, OMH3131 (B, S versions)

OMH090, OMH3019, OMH3020, OMH3040, OMH3075, OMH3131 (B, S)

**Magnetic Operate & Release Points vs Temperature**

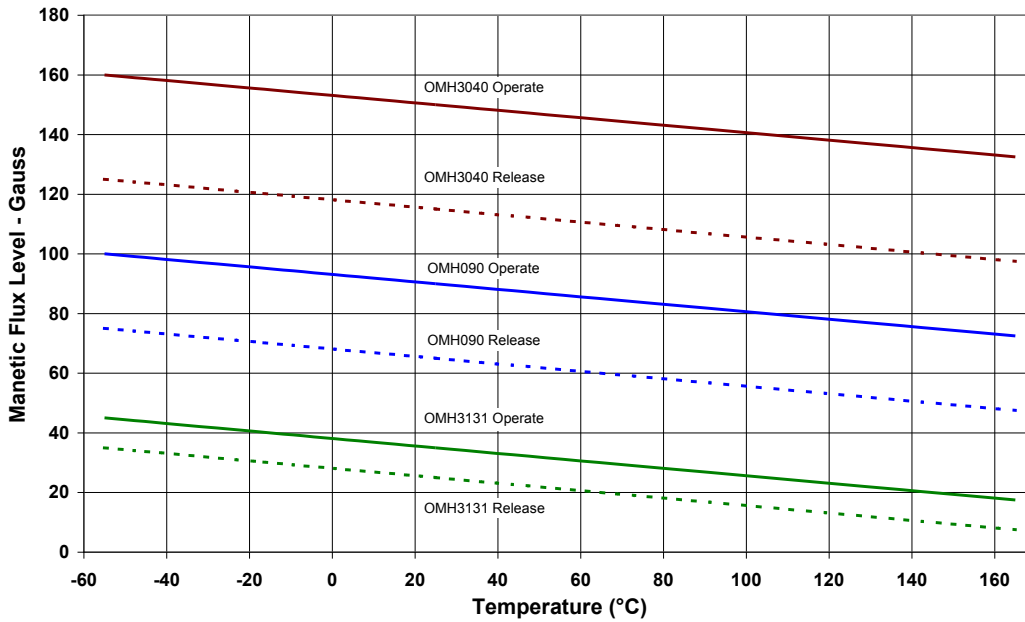

**Magnetic Operate & Release Points vs Temperature**

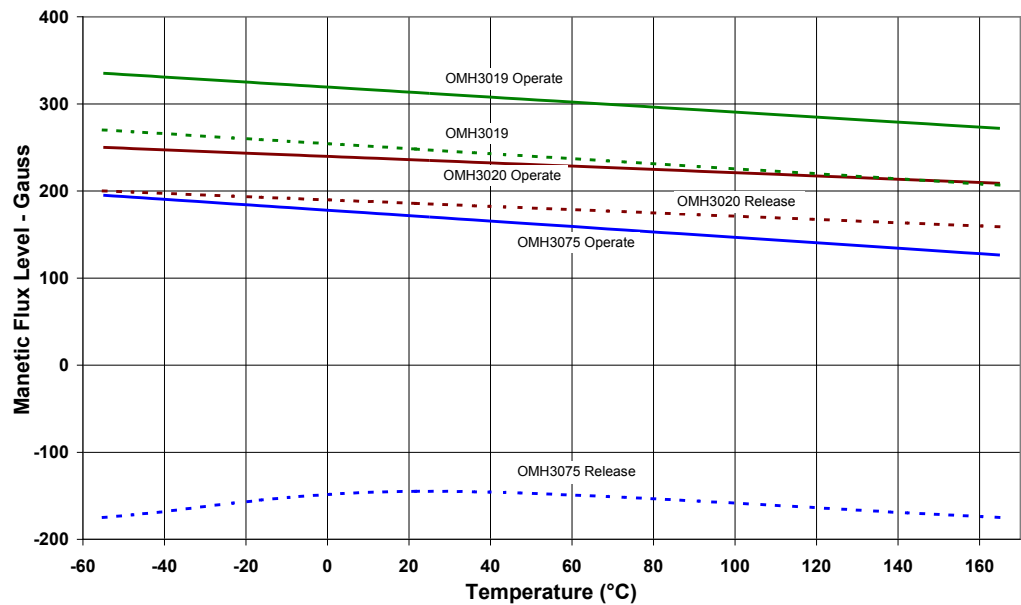

General Note  
TT Electronics reserves the right to make changes in product specification without notice or liability. All information is subject to TT Electronics' own data and is considered accurate at time of going to print.

OPTEK Technology, Inc.  
1645 Wallace Drive, Carrollton, TX 75006 | Ph: +1 972 323 2200  
www.optekinc.com | www.ttelectronics.com

# High Reliability Hallogic® Hall-Effect Sensors



OMH090, OMH3019, OMH3020, OMH3040,  
OMH3075, OMH3131 (B, S versions)

OMH090, OMH3019, OMH3020, OMH3040, OMH3075, OMH3131 (B, S)

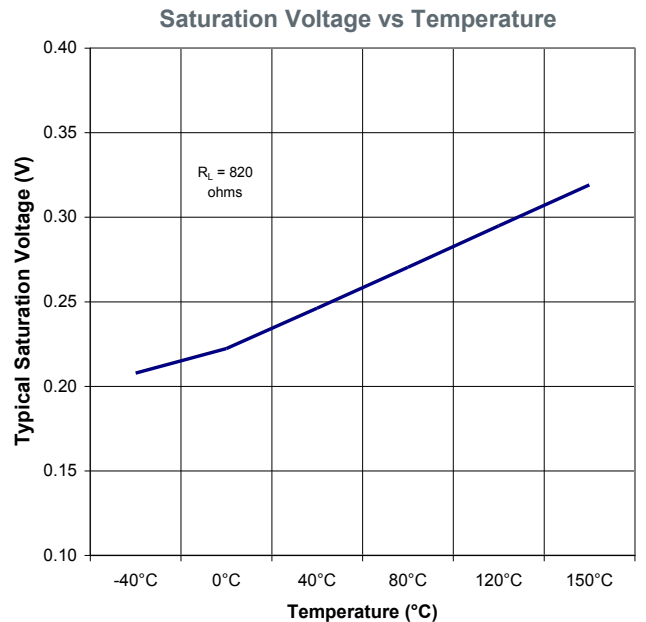
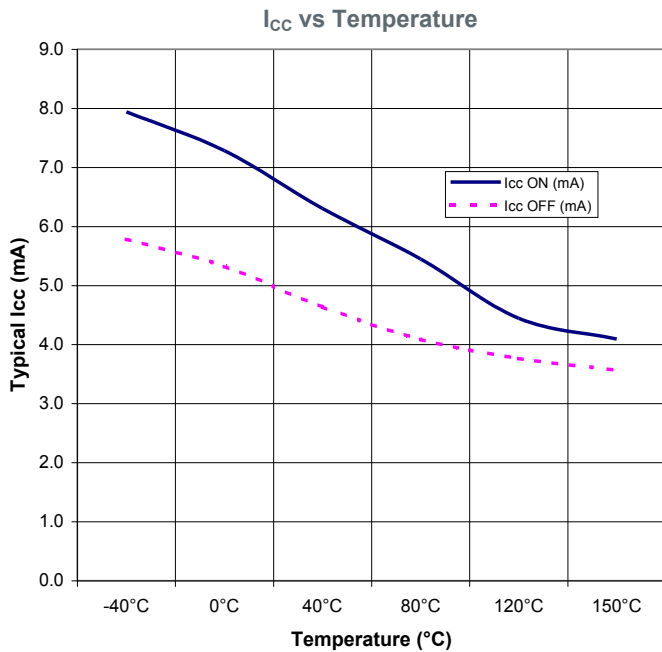
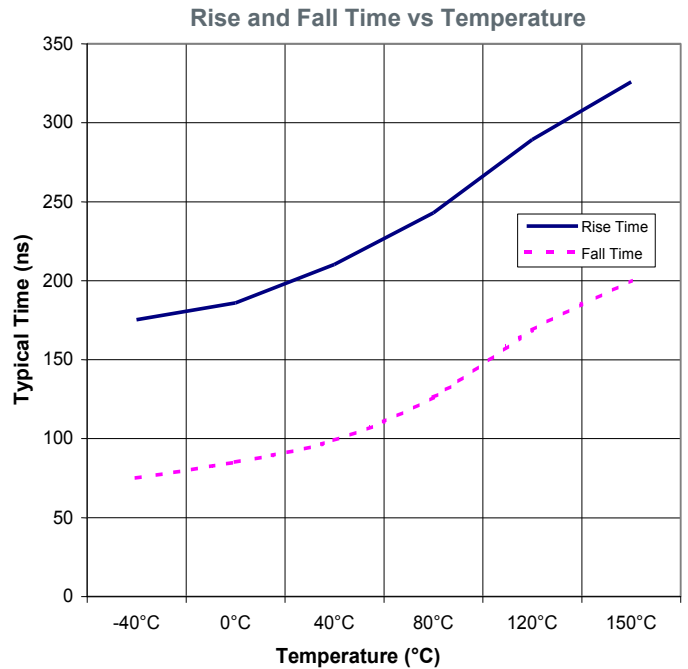
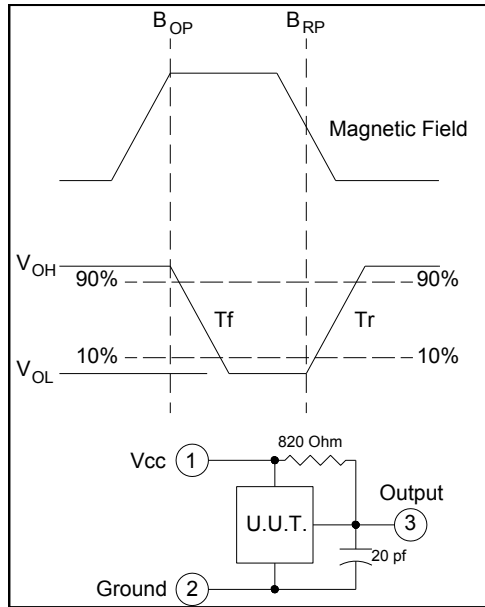

General Note  
TT Electronics reserves the right to make changes in product specification without notice or liability. All information is subject to TT Electronics' own data and is considered accurate at time of going to print.

OPTEK Technology, Inc.  
1645 Wallace Drive, Carrollton, TX 75006 | Ph: +1 972 323 2200  
www.optekinc.com | www.ttelectronics.com

# High Reliability Hallogig<sup>®</sup> Hall-Effect Sensors



OMH090, OMH3019, OMH3020, OMH3040,  
OMH3075, OMH3131 (B, S versions)

Issue	Change Description	Approval	Date
A	Initial Release		02/05
A.1	Put into new template. Required changes on all pages. Added new .jpg logo. Updated data and graphs		08/18/06
B	Updated graphs and Typical Op and Rel points for OMH3075	Sergio DeLaGarza	03/09/07
B.1	Added sentence to Description last paragraph on front page	Sergio DeLaGarza	06/06/07
C	Added SMD versions	Sergio DeLaGarza	05/21/08
C.1	Added Lead finish = Solder Dipped (Sn 63/37), added Rad Hard testing on page 1	Sergio DeLaGarza	07/31/08
C.2	Delete both SMD illustrations from cover page. Delete all –SM part numbers from table on page 2.	Sergio DeLaGarza	2/18/09
C.3	Change test conditions for tests $I_{CC}$ & $I_{OH}$ .	Sergio DeLaGarza	5/28/10
C.4	Change 100 Krad to 150 Krad. Update dimensions on through hole illustration.	Sergio DeLaGarza	6/3/10
D	Add 10 to Max for Supply Current at –55°C	Sergio DeLaGarza	9/20/10
E	Update schematic on page 1 and add “Add capacitor...” note.	Sergio DeLaGarza	11/9/10
F	Add ESD rating bullet to first page. Update limits for OMH090B,S, OMH3019B, S, OMH3020B, S & OMH3040B & S. Update the BH, BOP and BRP limits in the Electrical Characteristics charts.	Sergio DeLaGarza	12/22/10
G	Change 300 to 250 under Magnetic Hysteresis. Change - to 15 under TYP for BH on the Electrical Characteristics table for OMH3131, OMH3131B etc.	Sergio DeLaGarza	1/7/11
H	Move OMH3131B & S to the Uni-Polar section on the Part Number chart on page 2	Sergio DeLaGarza	11/8/11
I	Update package outline on page 1, $I_{CC}$ electrical test condition for OMH3075 & 3040	Sergio DeLaGarza	8/4/14
J	Delete the surface mount.....lead length feature from page 1.	Sergio DeLaGarza	11/2/15
K	Updated Supply Current Test Conditions pg 5—changed Output On, $B \leq 250$ to Output Off, $B \leq -250$ . And, Output Leakage Current from $B \leq 250$ to $B \leq -250$	Mark Miller	05/17/16
K-1	Pg 2 changed Operate Point Gauss for OMH090B from 70/90/200 to 50/90/180; pg 3 changed $B_{OP}$ Min from 45, 70, 20 to 45, 50, 20 and Max from 210, 200, 180 to 210, 180, 180; pg 3 changed BRP Min from 30, 25 to 25, 30, 25 and Max from 180, 170 to 150, 180, 1400 and Test conditions changed “-55°C ^ + 25°C” to “-55°C”; pg 3 changed ICC Test conditions “+55°C, $V_{CC} = 24$ V, Output On, $B \leq 250$ Gauss” to “-55°C, $V_{CC} = 24$ V, Output On, $B \geq 250$ Gauss”; pg 5 changed ICC Test conditions from “+25°C, $V_{CC} = 24$ V, (Output Off), $B \leq -250$ Gauss” to “+25°C, $V_{CC} = 24$ V, (Output On), $B \geq -250$ Gauss”	Rodney Bailey	08/17/16

## Looking for pricing, stock, or lifecycle information?

Click below to explore more details on WIN SOURCE:

 [View OMH3020B](#) on WIN SOURCE

 [TT Electronics](#) Information

## Optimize Your Supply Chain with WIN SOURCE Solutions

-  Global Sourcing Solution
-  Obsolete Management
-  Cost Control Management
-  Shortage Management
-  Alternative Solution
-  Excess Inventory Management