



**THE DATASHEET OF  
IRG7PH30K10DPBF**

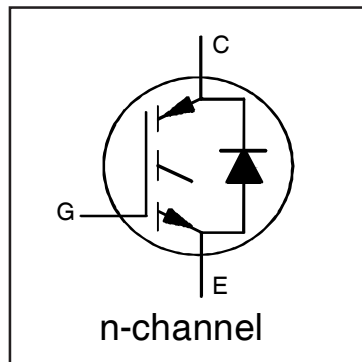


# IRG7PH30K10DPbF

## INSULATED GATE BIPOLAR TRANSISTOR WITH ULTRAFAST SOFT RECOVERY DIODE

### Features

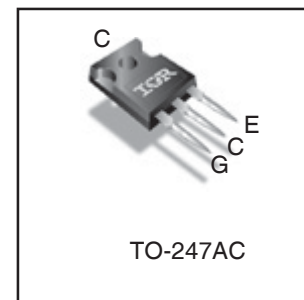
- Low  $V_{CE(ON)}$  Trench IGBT Technology
- Low switching losses
- 10  $\mu$ S short circuit SOA
- Square RBSOA
- 100% of the parts tested for  $I_{LM}$  ①
- Positive  $V_{CE(ON)}$  Temperature co-efficient
- Ultra fast soft Recovery Co-Pak Diode
- Tight parameter distribution
- Lead Free Package



$V_{CES} = 1200V$
$I_C = 16A, T_C = 100^\circ C$
$t_{SC} \geq 10\mu s, T_{J(max)} = 150^\circ C$
$V_{CE(on)} \text{ typ.} = 2.05V$

### Benefits

- High Efficiency in a wide range of applications
- Suitable for a wide range of switching frequencies due to Low  $V_{CE(ON)}$  and Low Switching losses
- Rugged transient Performance for increased reliability
- Excellent Current sharing in parallel operation



<b>G</b>	<b>C</b>	<b>E</b>
Gate	Collector	Emitter

### Absolute Maximum Ratings

	Parameter	Max.	Units
$V_{CES}$	Collector-to-Emitter Voltage	1200	V
$I_C @ T_C = 25^\circ C$	Continuous Collector Current	30	A
$I_C @ T_C = 100^\circ C$	Continuous Collector Current	16	
$I_{NOMINAL}$	Nominal Current	9.0	
$I_{CM}$	Pulse Collector Current, $V_{ge} = 15V$	27	
$I_{LM}$	Clamped Inductive Load Current, $V_{ge} = 20V$ ①	36	
$I_F @ T_C = 25^\circ C$	Diode Continuous Forward Current	30	
$I_F @ T_C = 100^\circ C$	Diode Continuous Forward Current	16	
$I_{FM}$	Diode Maximum Forward Current ②	36	
$V_{GE}$	Continuous Gate-to-Emitter Voltage	$\pm 30$	
$P_D @ T_C = 25^\circ C$	Maximum Power Dissipation	180	W
$P_D @ T_C = 100^\circ C$	Maximum Power Dissipation	71	
$T_J$	Operating Junction and	-55 to +150	$^\circ C$
$T_{STG}$	Storage Temperature Range		
	Soldering Temperature, for 10 sec.		
	Mounting Torque, 6-32 or M3 Screw	10 lbf·in (1.1 N·m)	

### Thermal Resistance

	Parameter	Min.	Typ.	Max.	Units
$R_{\theta JC}$ (IGBT)	Thermal Resistance Junction-to-Case-(each IGBT) ④	—	—	0.70	$^\circ C/W$
$R_{\theta JC}$ (Diode)	Thermal Resistance Junction-to-Case-(each Diode) ④	—	—	1.44	
$R_{\theta CS}$	Thermal Resistance, Case-to-Sink (flat, greased surface)	—	0.24	—	
$R_{\theta JA}$	Thermal Resistance, Junction-to-Ambient (typical socket mount)	—	40	—	

## Electrical Characteristics @ $T_J = 25^\circ\text{C}$ (unless otherwise specified)

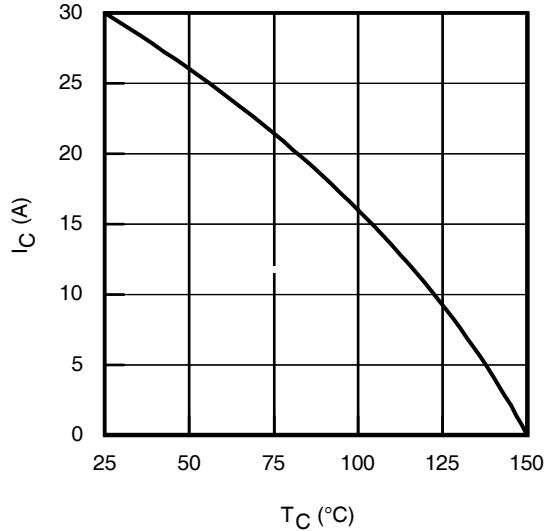
	Parameter	Min.	Typ.	Max.	Units	Conditions	Ref.Fig
$V_{(BR)CES}$	Collector-to-Emitter Breakdown Voltage	1200	—	—	V	$V_{GE} = 0V, I_C = 250\mu A$ ③	CT6
$\Delta V_{(BR)CES}/\Delta T_J$	Temperature Coeff. of Breakdown Voltage	—	1.11	—	V/°C	$V_{GE} = 0V, I_C = 1mA$ (25°C-150°C)	CT6
$V_{CE(on)}$	Collector-to-Emitter Saturation Voltage	—	2.05	2.35	V	$I_C = 9.0A, V_{GE} = 15V, T_J = 25^\circ\text{C}$	5,6,7
		—	2.56	—		$I_C = 9.0A, V_{GE} = 15V, T_J = 150^\circ\text{C}$	9,10,11
$V_{GE(th)}$	Gate Threshold Voltage	5.0	—	7.5	V	$V_{CE} = V_{GE}, I_C = 400\mu A$	9,10
$\Delta V_{GE(th)}/\Delta T_J$	Threshold Voltage temp. coefficient	—	-15	—	mV/°C	$V_{CE} = V_{GE}, I_C = 400\mu A$ (25°C - 150°C)	11,12
$g_{fe}$	Forward Transconductance	—	6.2	—	S	$V_{CE} = 50V, I_C = 9.0A, PW = 80\mu s$	
$I_{CES}$	Collector-to-Emitter Leakage Current	—	1.0	25	$\mu A$	$V_{GE} = 0V, V_{CE} = 1200V$	
		—	400	—		$V_{GE} = 0V, V_{CE} = 1200V, T_J = 150^\circ\text{C}$	
$V_{FM}$	Diode Forward Voltage Drop	—	2.0	3.0	V	$I_F = 9.0A$	8
		—	2.1	—		$I_F = 9.0A, T_J = 150^\circ\text{C}$	
$I_{GES}$	Gate-to-Emitter Leakage Current	—	—	$\pm 100$	nA	$V_{GE} = \pm 30V$	

## Switching Characteristics @ $T_J = 25^\circ\text{C}$ (unless otherwise specified)

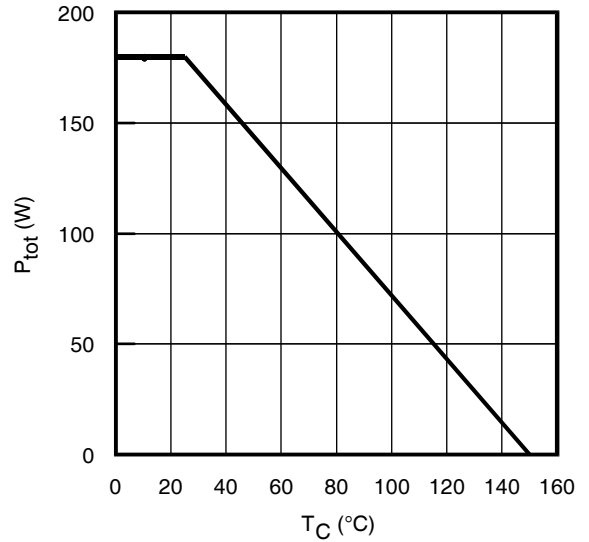
	Parameter	Min.	Typ.	Max.	Units	Conditions	Ref.Fig
$Q_g$	Total Gate Charge (turn-on)	—	45	68	nC	$I_C = 9.0A$ $V_{GE} = 15V$ $V_{CC} = 600V$	24
$Q_{ge}$	Gate-to-Emitter Charge (turn-on)	—	8.7	13			CT1
$Q_{gc}$	Gate-to-Collector Charge (turn-on)	—	20	30			
$E_{on}$	Turn-On Switching Loss	—	530	760	$\mu J$	$I_C = 9.0A, V_{CC} = 600V, V_{GE} = 15V$ $R_G = 22\Omega, L = 1.0mH, L_S = 150nH, T_J = 25^\circ\text{C}$ Energy losses include tail & diode reverse recovery	CT4
$E_{off}$	Turn-Off Switching Loss	—	380	600			
$E_{total}$	Total Switching Loss	—	910	1360			
$t_{d(on)}$	Turn-On delay time	—	14	31	ns	$I_C = 9.0A, V_{CC} = 600V, V_{GE} = 15V$ $R_G = 22\Omega, L = 1.0mH, L_S = 150nH, T_J = 25^\circ\text{C}$	CT4
$t_r$	Rise time	—	24	41			
$t_{d(off)}$	Turn-Off delay time	—	110	130			
$t_f$	Fall time	—	38	56			
$E_{on}$	Turn-On Switching Loss	—	810	—	$\mu J$	$I_C = 9.0A, V_{CC} = 600V, V_{GE} = 15V$ $R_G = 22\Omega, L = 1.0mH, L_S = 150nH, T_J = 150^\circ\text{C}$ ③ Energy losses include tail & diode reverse recovery	13,15
$E_{off}$	Turn-Off Switching Loss	—	680	—			CT4
$E_{total}$	Total Switching Loss	—	1490	—			WF1, WF2
$t_{d(on)}$	Turn-On delay time	—	11	—	ns	$I_C = 9.0A, V_{CC} = 600V, V_{GE} = 15V$ $R_G = 22\Omega, L = 1.0mH, L_S = 150nH$ $T_J = 150^\circ\text{C}$	14,16
$t_r$	Rise time	—	23	—			CT4
$t_{d(off)}$	Turn-Off delay time	—	130	—			WF1
$t_f$	Fall time	—	260	—			WF2
$C_{ies}$	Input Capacitance	—	1070	—	pF	$V_{GE} = 0V$ $V_{CC} = 30V$ $f = 1.0MHz$	23
$C_{oes}$	Output Capacitance	—	63	—			
$C_{res}$	Reverse Transfer Capacitance	—	26	—			
RBSOA	Reverse Bias Safe Operating Area	FULL SQUARE				$T_J = 150^\circ\text{C}, I_C = 36A$ $V_{CC} = 960V, V_p = 1200V$ $R_g = 22\Omega, V_{GE} = +20V$ to 0V	4 CT2
SCSOA	Short Circuit Safe Operating Area	10	—	—	$\mu s$	$T_J = 150^\circ\text{C}, V_{CC} = 600V, V_p = 1200V$ $R_g = 22\Omega, V_{GE} = +15V$ to 0V	22, CT3 WF4
$E_{rec}$	Reverse Recovery Energy of the Diode	—	710	—	$\mu J$	$T_J = 150^\circ\text{C}$	17,18,19
$t_{rr}$	Diode Reverse Recovery Time	—	140	—	ns	$V_{CC} = 600V, I_F = 9.0A$	20,21
$I_{rr}$	Peak Reverse Recovery Current	—	12	—	A	$V_{GE} = 15V, R_g = 20\Omega, L = 1.0mH, L_S = 150nH$	WF3

### Notes:

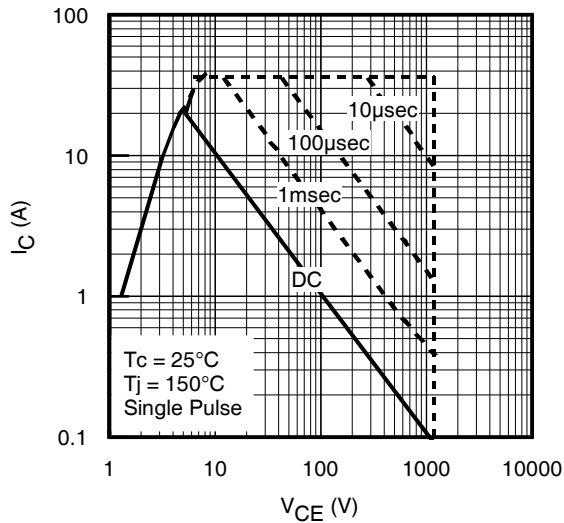
- $V_{CC} = 80\% (V_{CES}), V_{GE} = 20V, L = 36\mu H, R_G = 33\Omega.$
- Pulse width limited by max. junction temperature.
- Refer to AN-1086 for guidelines for measuring  $V_{(BR)CES}$  safely.
- $R_g$  is measured at  $T_J$  of approximately  $90^\circ\text{C}.$



**Fig. 1 - Maximum DC Collector Current vs. Case Temperature**

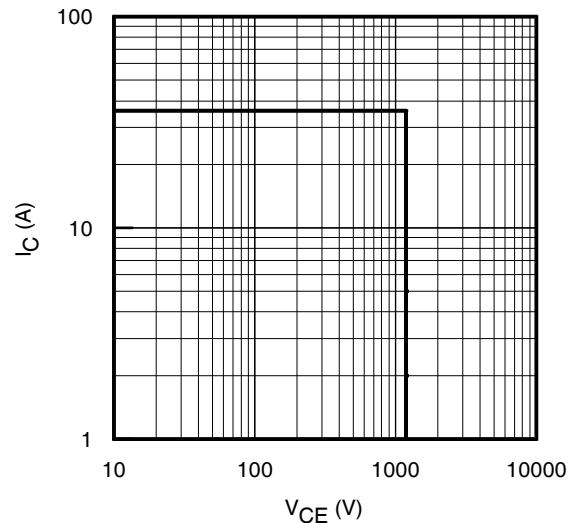


**Fig. 2 - Power Dissipation vs. Case Temperature**



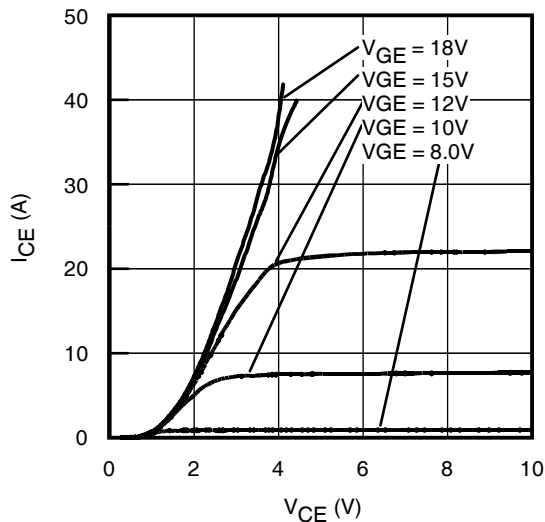
**Fig. 3 - Forward SOA**

$T_C = 25^\circ\text{C}$ ,  $T_J \leq 150^\circ\text{C}$ ;  $V_{GE} = 15\text{V}$

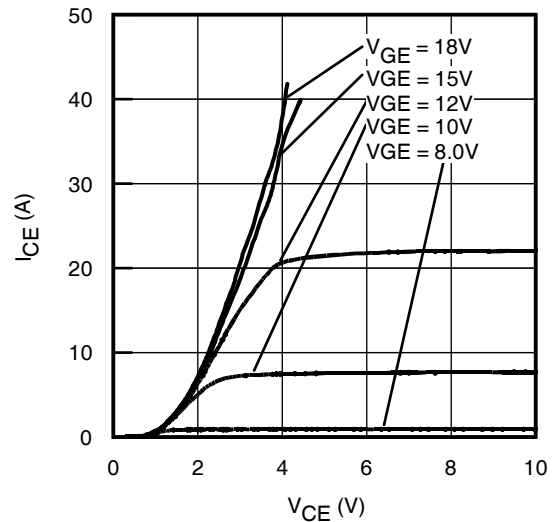


**Fig. 4 - Reverse Bias SOA**

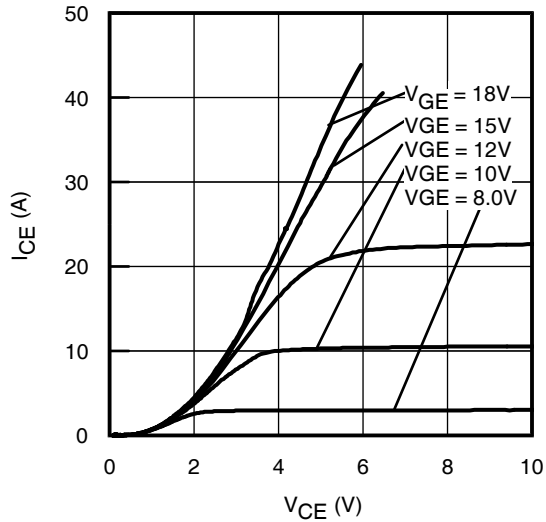
$T_J = 150^\circ\text{C}$ ;  $V_{GE} = 20\text{V}$



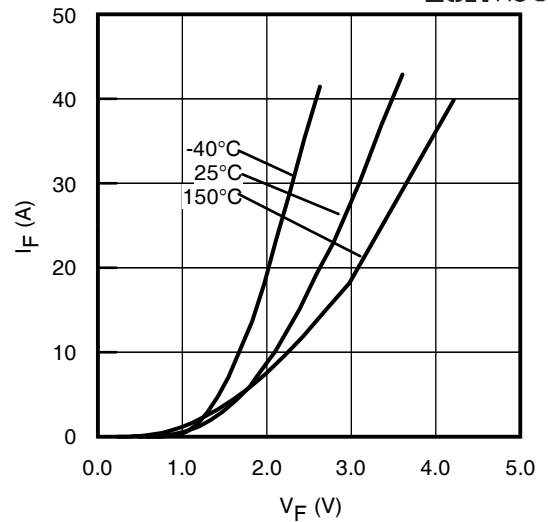
**Fig. 5 - Typ. IGBT Output Characteristics**  
 $T_J = -40^\circ\text{C}$ ;  $t_p = 80\mu\text{s}$



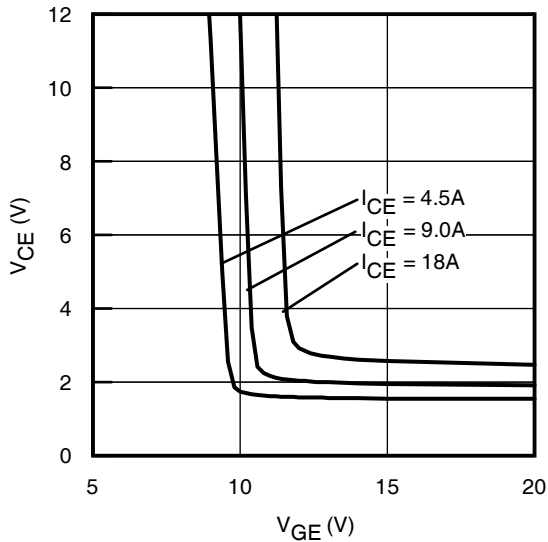
**Fig. 6 - Typ. IGBT Output Characteristics**  
 $T_J = 25^\circ\text{C}$ ;  $t_p = 80\mu\text{s}$



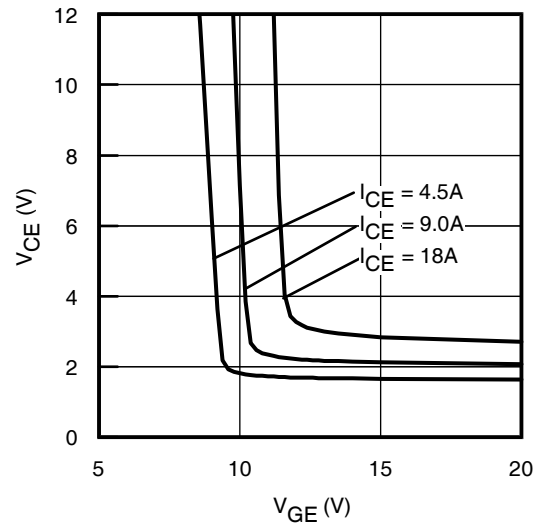
**Fig. 7** - Typ. IGBT Output Characteristics  
 $T_J = 150^\circ\text{C}$ ;  $t_p = 80\mu\text{s}$



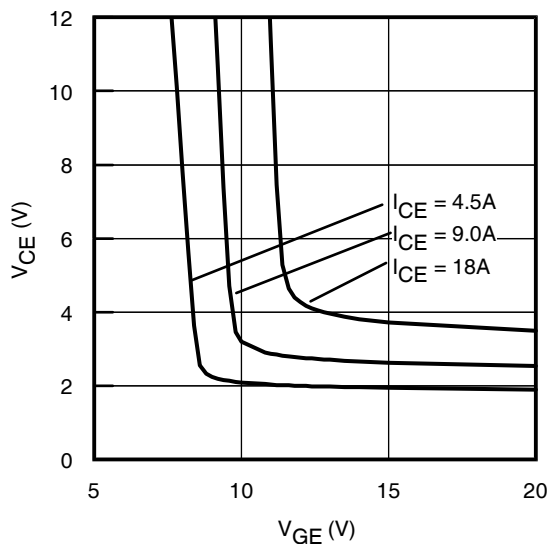
**Fig. 8** - Typ. Diode Forward Characteristics  
 $t_p = 80\mu\text{s}$



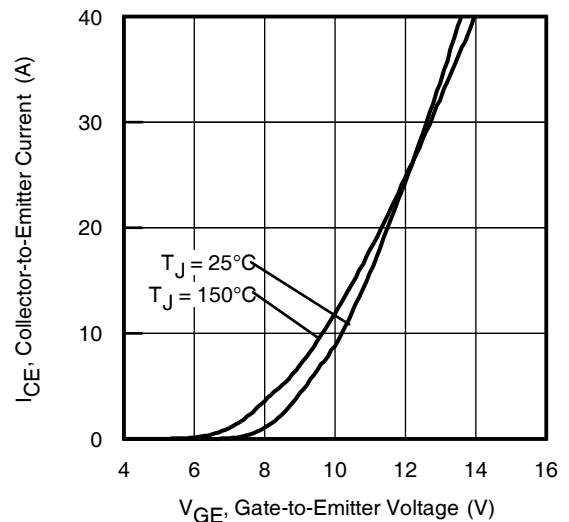
**Fig. 9** - Typical  $V_{CE}$  vs.  $V_{GE}$   
 $T_J = -40^\circ\text{C}$



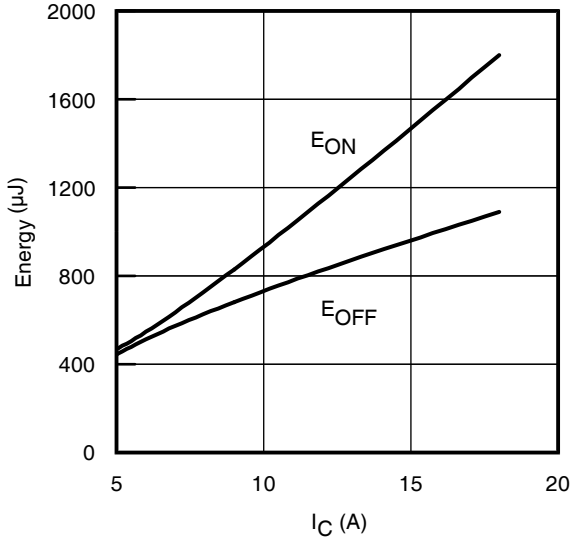
**Fig. 10** - Typical  $V_{CE}$  vs.  $V_{GE}$   
 $T_J = 25^\circ\text{C}$



**Fig. 11** - Typical  $V_{CE}$  vs.  $V_{GE}$   
 $T_J = 150^\circ\text{C}$

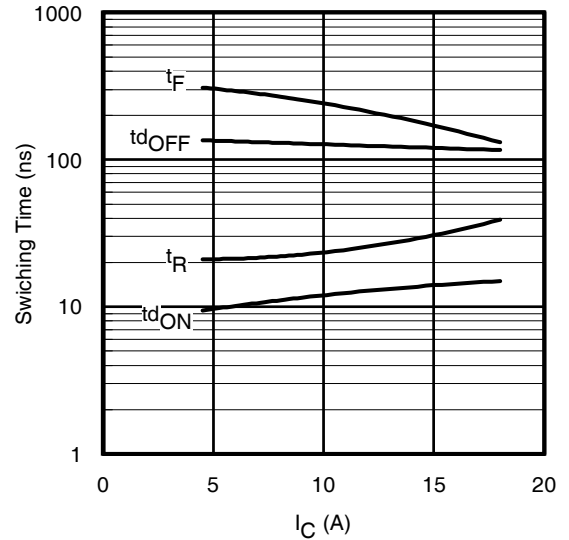


**Fig. 12** - Typ. Transfer Characteristics  
 $V_{CE} = 50\text{V}$



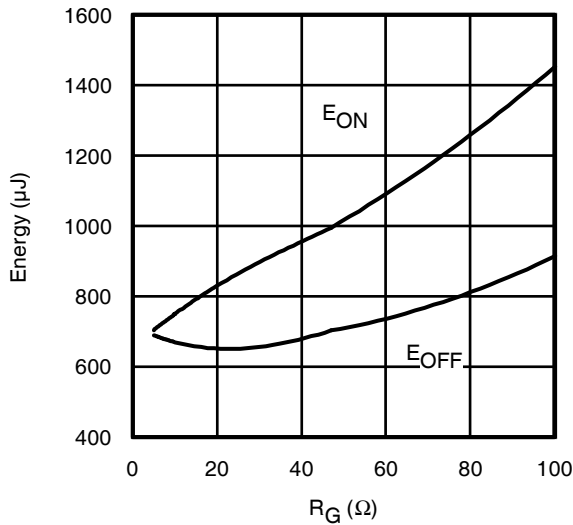
**Fig. 13** - Typ. Energy Loss vs.  $I_C$

$T_J = 150^\circ\text{C}$ ;  $L = 1.0\text{mH}$ ;  $V_{CE} = 600\text{V}$ ,  $R_G = 22\Omega$ ;  $V_{GE} = 15\text{V}$



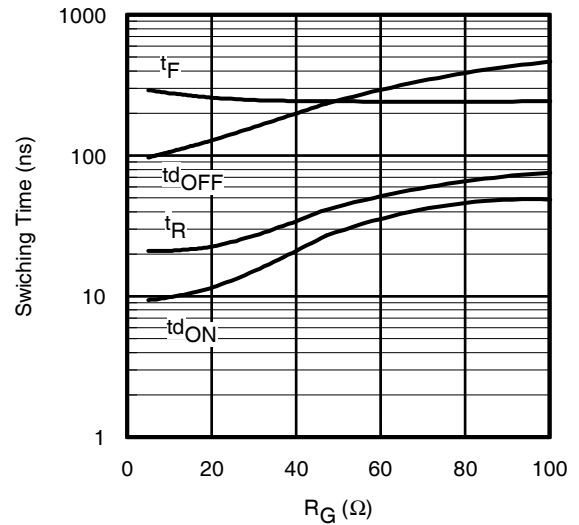
**Fig. 14** - Typ. Switching Time vs.  $I_C$

$T_J = 150^\circ\text{C}$ ;  $L = 1.0\text{mH}$ ;  $V_{CE} = 600\text{V}$ ,  $R_G = 22\Omega$ ;  $V_{GE} = 15\text{V}$



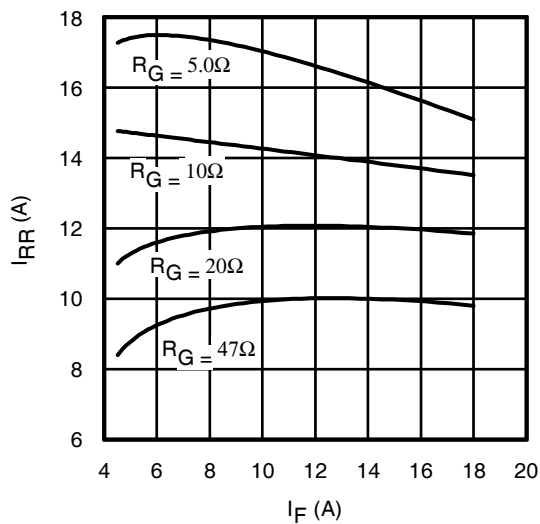
**Fig. 15** - Typ. Energy Loss vs.  $R_G$

$T_J = 150^\circ\text{C}$ ;  $L = 1.0\text{mH}$ ;  $V_{CE} = 600\text{V}$ ,  $I_{CE} = 9.0\text{A}$ ;  $V_{GE} = 15\text{V}$

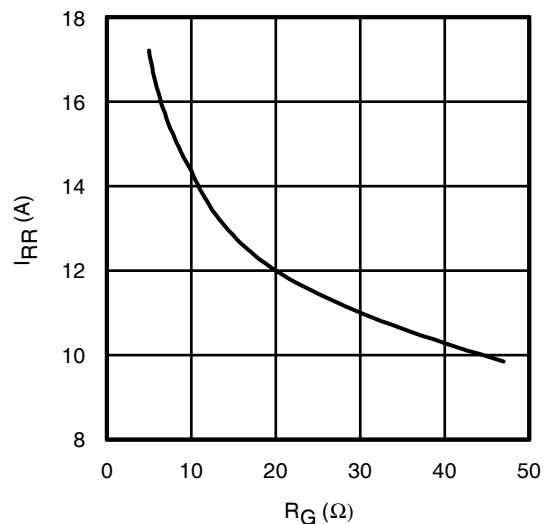


**Fig. 16** - Typ. Switching Time vs.  $R_G$

$T_J = 150^\circ\text{C}$ ;  $L = 1.0\text{mH}$ ;  $V_{CE} = 600\text{V}$ ,  $I_{CE} = 9.0\text{A}$ ;  $V_{GE} = 15\text{V}$

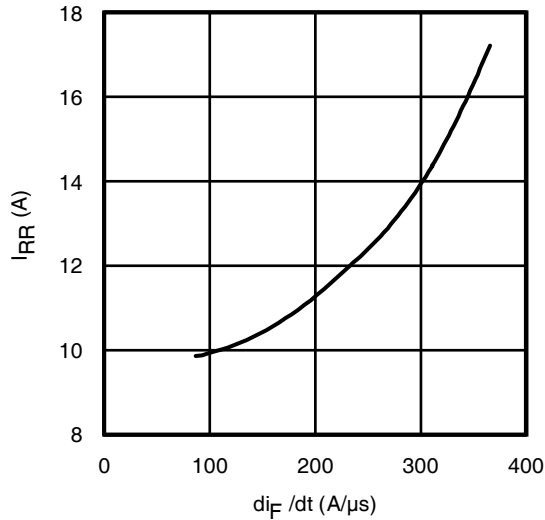


**Fig. 17** - Typ. Diode  $I_{RR}$  vs.  $I_F$   
 $T_J = 150^\circ\text{C}$

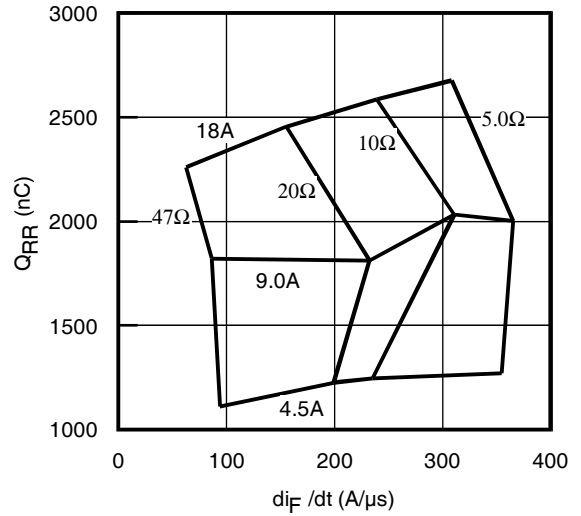


**Fig. 18** - Typ. Diode  $I_{RR}$  vs.  $R_G$   
 $T_J = 150^\circ\text{C}$

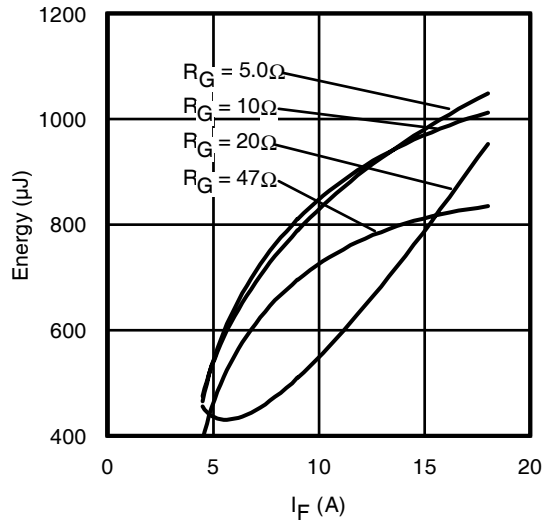
# IRG7PH30K10DPbF



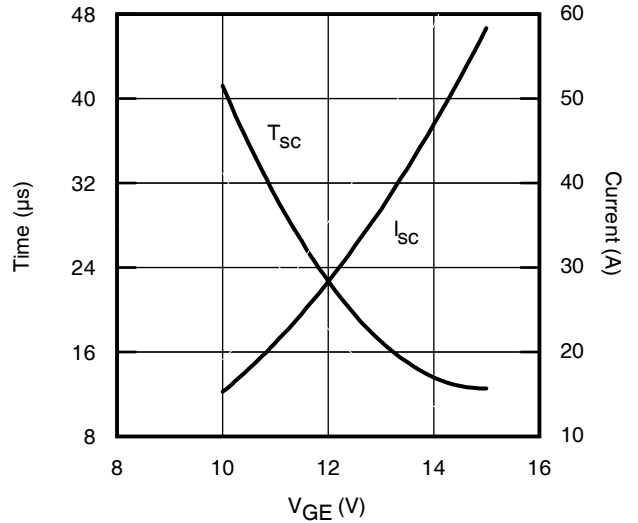
**Fig. 19** - Typ. Diode  $I_{RR}$  vs.  $di_F/dt$   
 $V_{CC} = 600V$ ;  $V_{GE} = 15V$ ;  $I_F = 9.0A$ ;  $T_J = 150^\circ C$



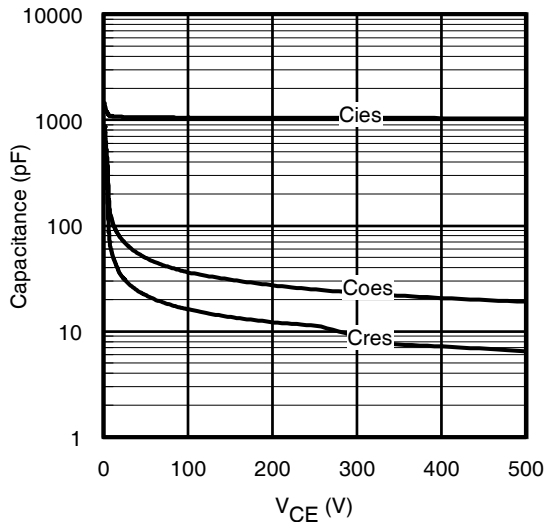
**Fig. 20** - Typ. Diode  $Q_{RR}$  vs.  $di_F/dt$   
 $V_{CC} = 600V$ ;  $V_{GE} = 15V$ ;  $T_J = 150^\circ C$



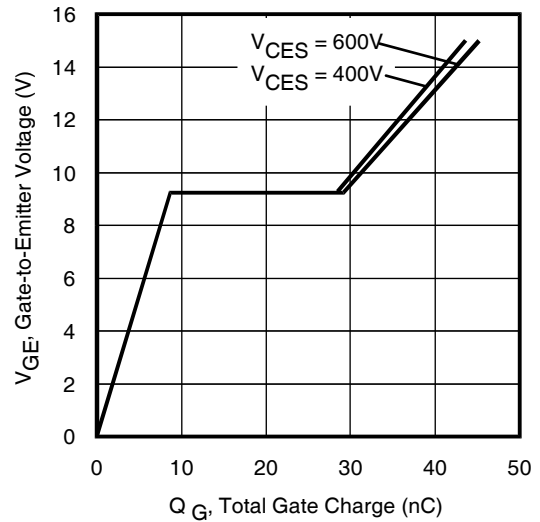
**Fig. 21** - Typ. Diode  $E_{RR}$  vs.  $I_F$   
 $T_J = 150^\circ C$



**Fig. 22** -  $V_{GE}$  vs. Short Circuit Time  
 $V_{CC} = 600V$ ;  $T_C = 150^\circ C$



**Fig. 23** - Typ. Capacitance vs.  $V_{CE}$   
 $V_{GE} = 0V$ ;  $f = 1MHz$



**Fig. 24** - Typical Gate Charge vs.  $V_{GE}$   
 $I_{CE} = 9.0A$ ;  $L = 600\mu H$

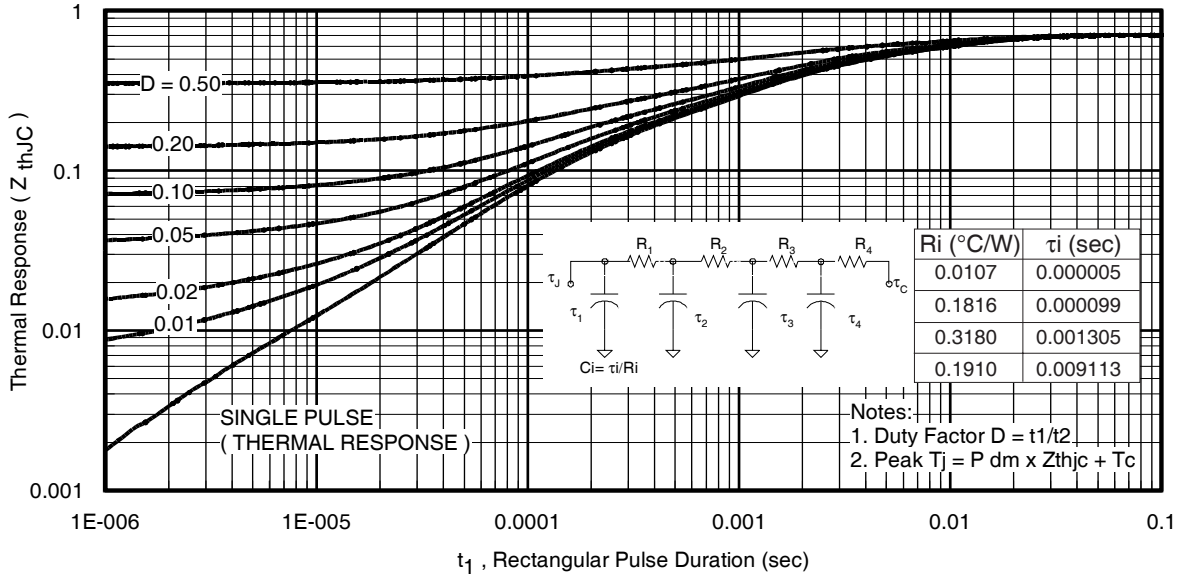


Fig 25. Maximum Transient Thermal Impedance, Junction-to-Case (IGBT)

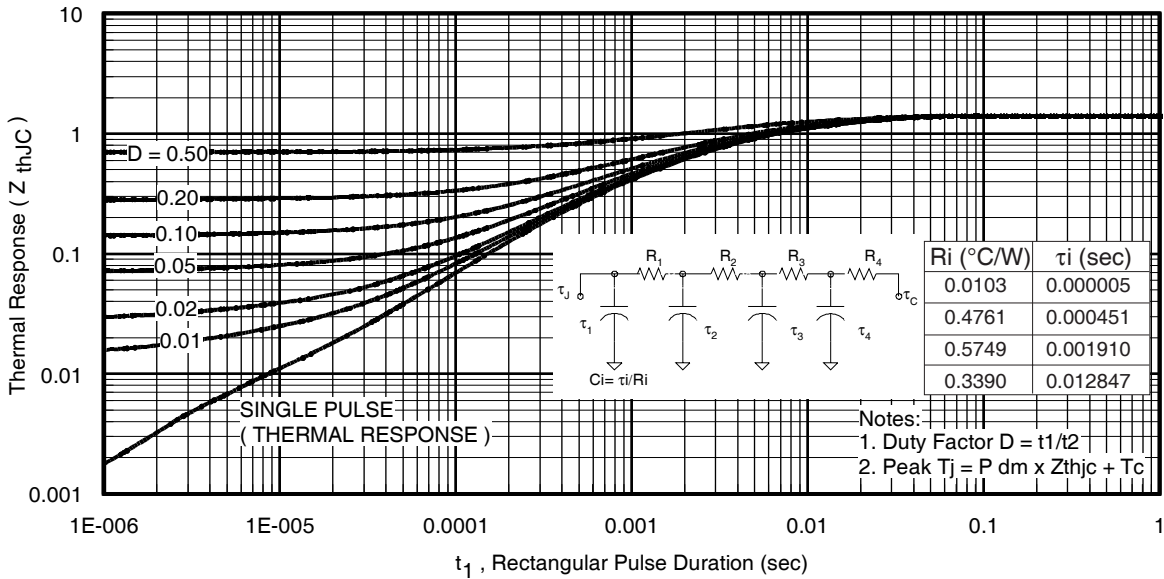
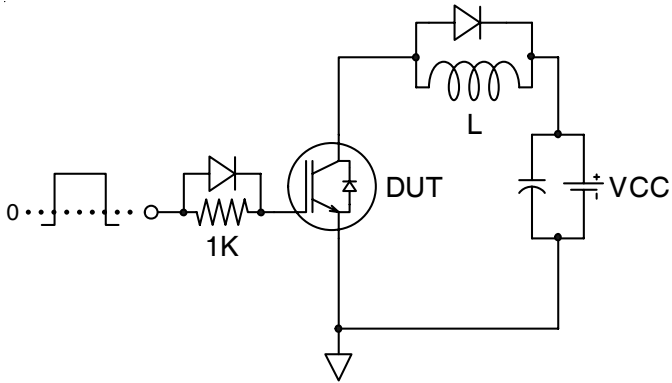
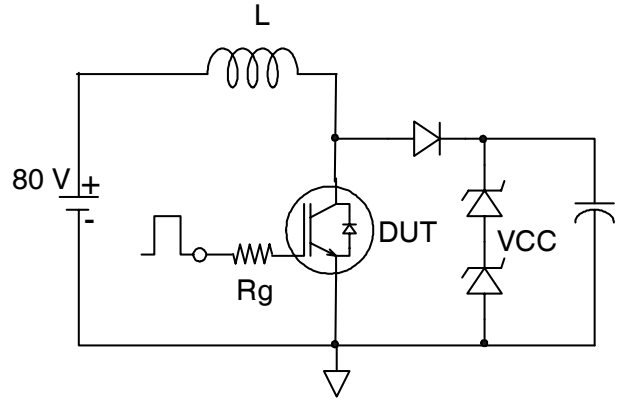


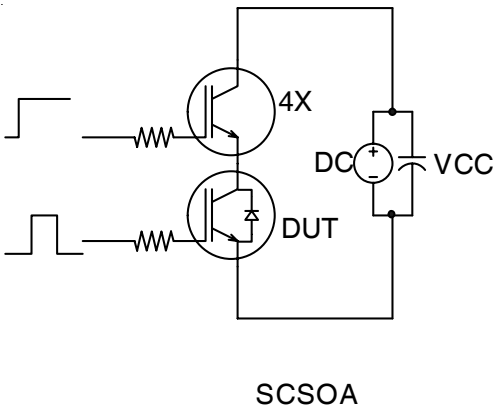
Fig. 26. Maximum Transient Thermal Impedance, Junction-to-Case (DIODE)



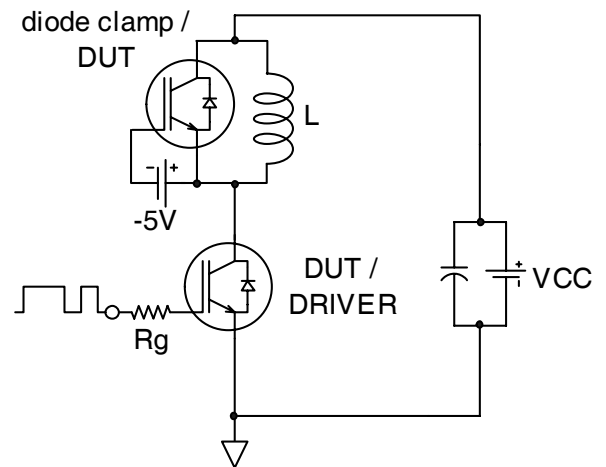
**Fig.C.T.1** - Gate Charge Circuit (turn-off)



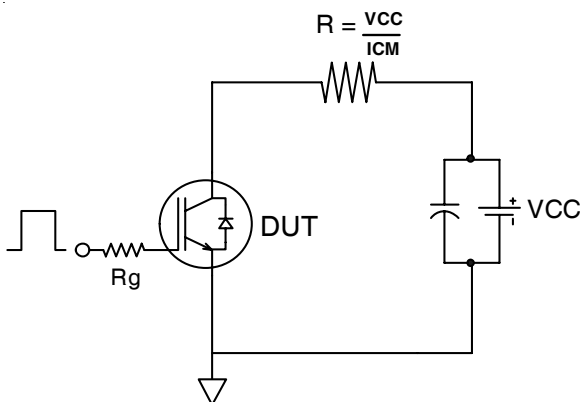
**Fig.C.T.2** - RBSOA Circuit



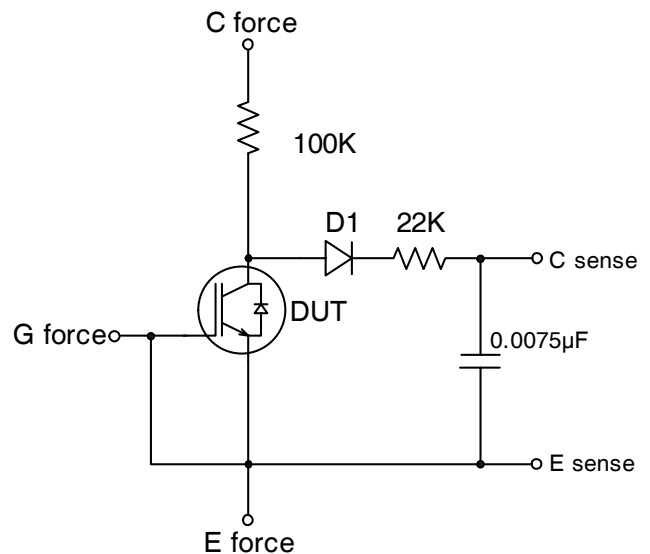
**Fig.C.T.3** - S.C. SOA Circuit



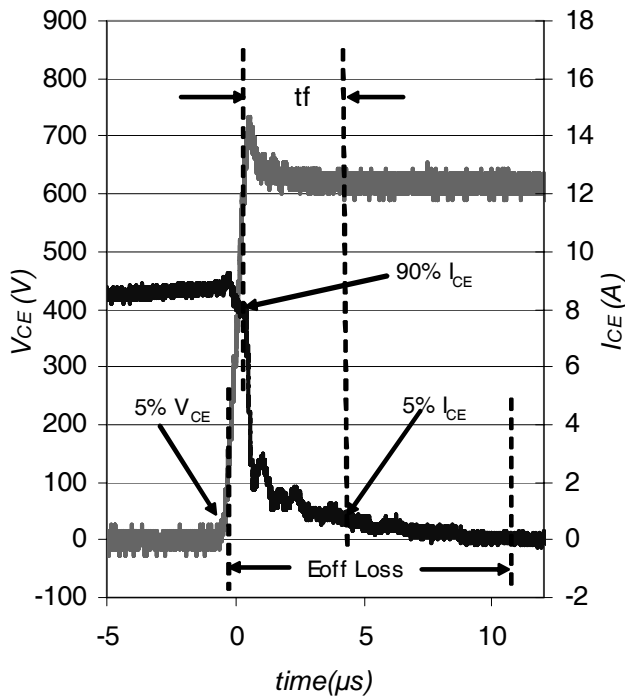
**Fig.C.T.4** - Switching Loss Circuit



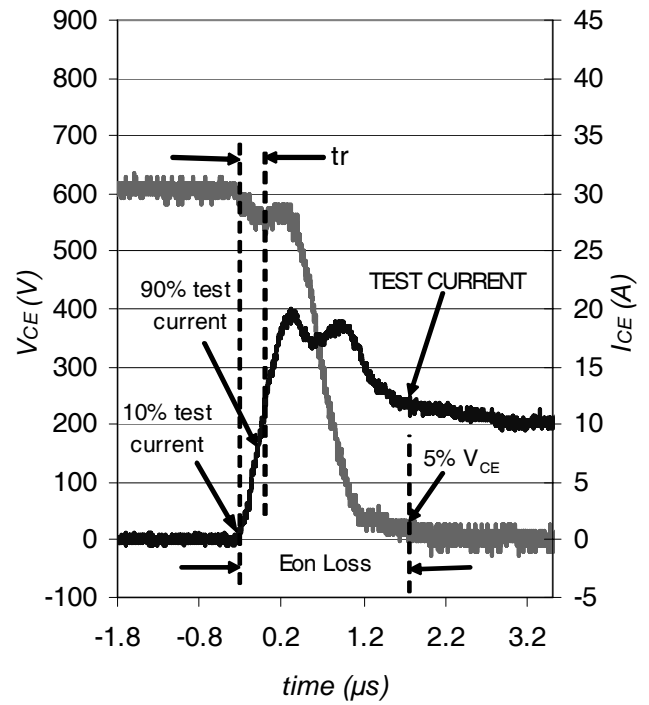
**Fig.C.T.5** - Resistive Load Circuit



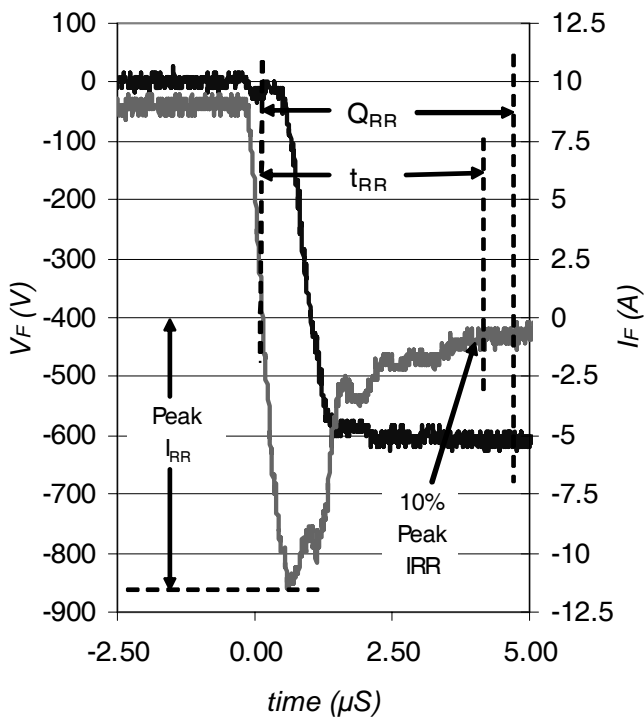
**Fig.C.T.6** - BVCES Filter Circuit



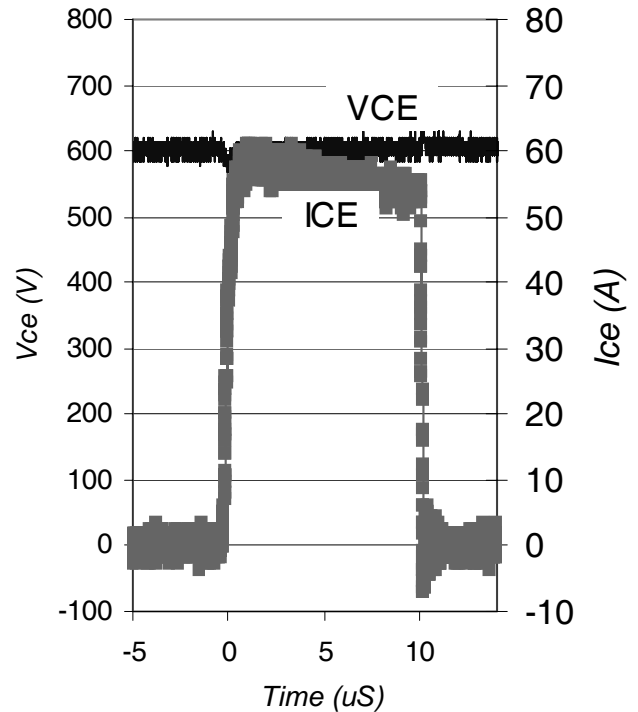
**Fig. WF1** - Typ. Turn-off Loss Waveform  
@  $T_J = 150^\circ\text{C}$  using Fig. CT.4



**Fig. WF2** - Typ. Turn-on Loss Waveform  
@  $T_J = 150^\circ\text{C}$  using Fig. CT.4



**Fig. WF3** - Typ. Diode Recovery Waveform  
@  $T_J = 150^\circ\text{C}$  using Fig. CT.4

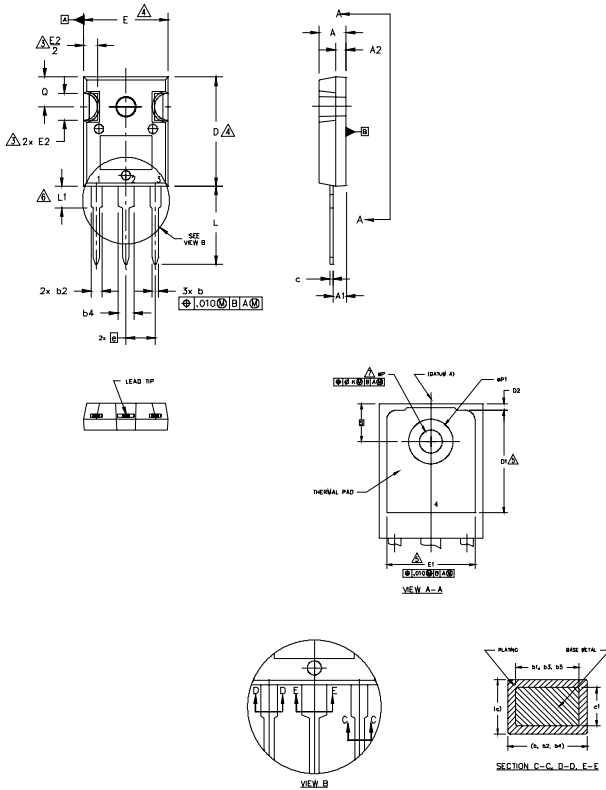


**Fig. WF4** - Typ. S.C. Waveform  
@  $T_J = 150^\circ\text{C}$  using Fig. CT.3

# IRG7PH30K10DPbF

## TO-247AC Package Outline

Dimensions are shown in millimeters (inches)



**NOTES:**

1. DIMENSIONING AND TOLERANCING AS PER ASME Y14.5M 1994.
2. DIMENSIONS ARE SHOWN IN INCHES.
3. CONTOUR OF SLOT OPTIONAL.
4. DIMENSION D & E DO NOT INCLUDE MOLD FLASH. MOLD FLASH SHALL NOT EXCEED .005" (0.127) PER SIDE. THESE DIMENSIONS ARE MEASURED AT THE OUTERMOST EXTREMES OF THE PLASTIC BODY.
5. THERMAL PAD CONTOUR OPTIONAL WITHIN DIMENSIONS D1 & E1.
6. LEAD FINISH UNCONTROLLED IN L1.
7. ØP TO HAVE A MAXIMUM DRAFT ANGLE OF 1.5 ° TO THE TOP OF THE PART WITH A MAXIMUM HOLE DIAMETER OF .154 INCH.
8. OUTLINE CONFORMS TO JEDEC OUTLINE TO-247AC .

SYMBOL	DIMENSIONS				NOTES
	INCHES		MILLIMETERS		
	MIN.	MAX.	MIN.	MAX.	
A	.183	.209	4.65	5.31	
A1	.087	.102	2.21	2.59	
A2	.059	.098	1.50	2.49	
b	.039	.055	0.99	1.40	
b1	.039	.053	0.99	1.35	
b2	.065	.094	1.65	2.39	
b3	.065	.092	1.65	2.34	
b4	.102	.135	2.59	3.43	
b5	.102	.133	2.59	3.38	
c	.015	.035	0.38	0.89	
c1	.015	.033	0.38	0.84	
D	.776	.815	19.71	20.70	4
D1	.515	-	13.08	-	5
D2	.020	.053	0.51	1.35	
E	.602	.625	15.29	15.87	4
E1	.530	-	13.46	-	
E2	.178	.216	4.52	5.49	
e	.215 BSC		5.46 BSC		
Øk	.010		0.25		
L	.559	.634	14.20	16.10	
L1	.146	.169	3.71	4.29	
ØP	.140	.144	3.56	3.66	
ØP1	-	.291	-	7.39	
Q	.209	.224	5.31	5.69	
S	.217 BSC		5.51 BSC		

**LEAD ASSIGNMENTS**

**HEXFET**

- 1.- GATE
- 2.- DRAIN
- 3.- SOURCE
- 4.- DRAIN

**IGBTs, CoPACK**

- 1.- GATE
- 2.- COLLECTOR
- 3.- EMITTER
- 4.- COLLECTOR

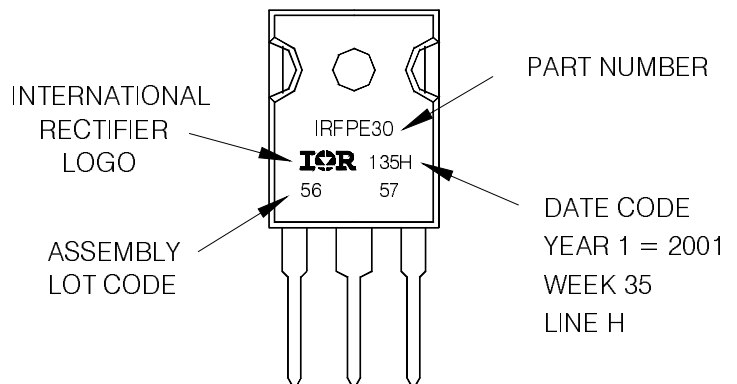
**DIODES**

- 1.- ANODE/OPEN
- 2.- CATHODE
- 3.- ANODE

## TO-247AC Part Marking Information

EXAMPLE: THIS IS AN IRFPE30  
WITH ASSEMBLY  
LOT CODE 5657  
ASSEMBLED ON WW 35, 2001  
IN THE ASSEMBLY LINE "H"

Note: "P" in assembly line position  
indicates "Lead-Free"



**TO-247AC package is not recommended for Surface Mount Application.**

Note: For the most current drawing please refer to IR website at <http://www.irf.com/package/>

Data and specifications subject to change without notice.  
This product has been designed and qualified for Industrial market.  
Qualification Standards can be found on IR's Web site.

## Looking for pricing, stock, or lifecycle information?

Click below to explore more details on WIN SOURCE:

 [View IRG7PH30K10DPBF on WIN SOURCE](#)

 [Infineon Technologies](#) Information

## Optimize Your Supply Chain with WIN SOURCE Solutions

-  Global Sourcing Solution
-  Obsolete Management
-  Cost Control Management
-  Shortage Management
-  Alternative Solution
-  Excess Inventory Management