



**THE DATASHEET OF
TPIC74101QPWPRQ1**



TPIC74101-Q1 Buck and Boost Switch-Mode Regulator

1 Features

- Qualified for Automotive Applications
- AEC-Q100 Qualified With the Following Results:
 - Device HBM ESD Classification level 1B for pin 7 (L2), pin 8 (V_{OUT}), pin 9 (5Vg)
 - Device HBM ESD Classification 2 for pins 1–6 and 10–20
 - Device CDM ESD Classification Level C4B
- Switch-Mode Regulator
 - 5 V ±2%, Buck Mode
 - 5 V ±3%, Low-Power or Boost or Boost/buck Crossover Mode
- Switching Frequency, 380 kHz (typical)
- Input Operating Range, 1.5 V to 40 V, (V_{driver})
 - 1-A Load-Current Capability
 - 200-mA Load-Current Capability Down to 2-V Input (V_{driver})
 - 120-mA Load-Current Capability Down to 1.5-V Input (V_{driver})
- Enable Function
- Low-Power Operation Mode
- Switched 5-V Regulated Output on 5Vg With Current Limit
- Programmable Slew Rate and Frequency Modulation for EMI Consideration
- Reset Function With Deglitch Timer and Programmable Delay
- Alarm Function for Undervoltage Detection and Indication
- Thermally Enhanced Package for Efficient Heat Management

2 Applications

- Automotive Infotainment & Cluster
- Body Electronics

3 Description

The TPIC74101-Q1 is a switch-mode regulator with integrated switches for voltage-mode control. With the aid of external components (LC combination), the device regulates the output to 5 V ±2% for a wide input-voltage range.

The TPIC74101-Q1 offers a reset function to detect and indicate when the 5-V output rail is outside of the specified tolerance. This reset delay is programmable using an external timing capacitor on the RESET Pin. Additionally, an alarm (A_{OUT}) feature is activated when the input supply rail V_{driver} is below a prescaled specified value (set by the A_{IN} pin).

The TPIC74101-Q1 has a frequency-modulation scheme to minimize EMI. The clock modulator permits a modulation of the switching frequency to reduce interference energy in the frequency band.

The 5Vg output is a switched 5-V regulated output with internal current limiting to prevent RESET from being asserted when powering a capacitive load on the supply line. This function is controlled by the 5Vg_ENABLE Pin. If there is a short to ground on this output (5Vg output), the output self-protects by operating in a chopping mode. This does, however, increase the output ripple voltage on V_{OUT} during this fault condition.

Device Information⁽¹⁾

PART NUMBER	PACKAGE	BODY SIZE (NOM)
TPIC74101-Q1	HTSSOP (20)	6.50 mm x 4.40 mm

(1) For all available packages, see the orderable addendum at the end of the datasheet.

Simplified Schematic

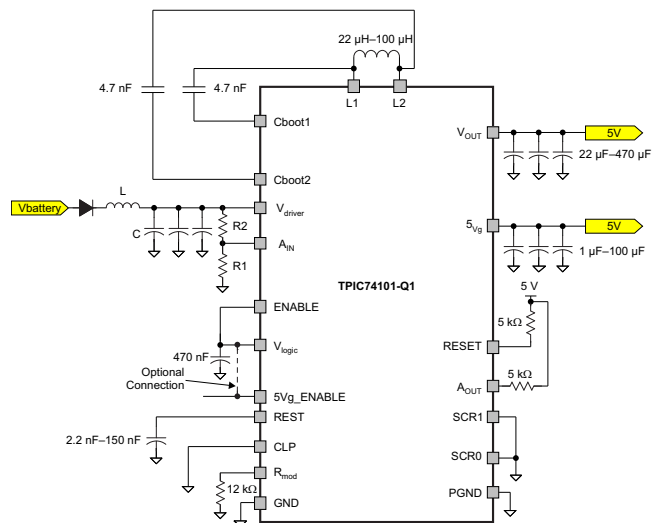

SD183-01



Table of Contents

1 Features	1	7.2 Functional Block Diagram	10
2 Applications	1	7.3 Feature Description	11
3 Description	1	7.4 Device Functional Modes	14
4 Revision History	2	8 Application and Implementation	17
5 Pin Configuration and Functions	3	8.1 Application Information	17
6 Specifications	4	8.2 Typical Application	17
6.1 Absolute Maximum Ratings	4	9 Power Supply Recommendations	20
6.2 ESD Ratings	4	10 Layout	20
6.3 Recommended Operating Conditions	4	10.1 Layout Guidelines	20
6.4 Thermal Information	5	10.2 Layout Example	23
6.5 Dissipation Rating	5	11 Device and Documentation Support	25
6.6 Electrical Characteristics	5	11.1 Trademarks	25
6.7 Typical Characteristics	7	11.2 Electrostatic Discharge Caution	25
7 Detailed Description	10	11.3 Glossary	25
7.1 Overview	10	12 Mechanical, Packaging, and Orderable Information	25

4 Revision History

Changes from Original (October 2011) to Revision A

Page

- Added *Pin Configuration and Functions* section, *ESD Rating* table, *Feature Description* section, *Device Functional Modes*, *Application and Implementation* section, *Power Supply Recommendations* section, *Layout* section, *Device and Documentation Support* section, and *Mechanical, Packaging, and Orderable Information* section **1**

5 Pin Configuration and Functions

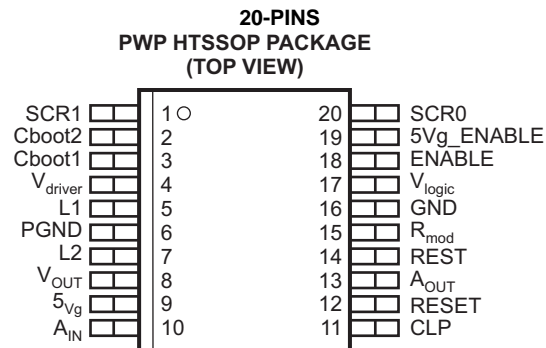

P0021-02

Pin Functions

PIN		I/O	DESCRIPTION
NAME	NO.		
SCR1	1	I	Programmable slew-rate control
Cboot2	2	I	External bootstrap capacitor
Cboot1	3	I	External bootstrap capacitor
V _{driver}	4	I	Input voltage source
L1	5	I	Inductor input (an external Schottky diode ⁽¹⁾ to GND must be connected to L1)
PGND	6	I	Power ground
L2	7	I	Inductor output
V _{OUT}	8	O	5-V regulated output
5Vg	9	O	Switched 5-V supply
A _{IN}	10	I	Programmable alarm setting
CLP	11	I/O	Low-power operation mode (digital input)
RESET	12	O	Reset function (open drain)
A _{OUT}	13	O	Alarm output (open drain)
REST	14	O	Programmable reset timer delay
R _{mod}	15	I	Main switching frequency modulation setting to minimize EMI
GND	16	I	Ground
V _{logic}	17	O	Supply decoupling output (may be used as a 5-V supply for logic-level inputs)
ENABLE	18	I	Switch-mode regulator enable/disable
5Vg_ENABLE	19	I	Switched 5-V voltage regulator output enable/disable
SCR0	20	I	Programmable slew-rate control

Exposed thermal pad of the package should be connected to GND or left floating.

(1) Maximum 0.4 V at 1 A and 125°C

6 Specifications

6.1 Absolute Maximum Ratings

 over recommended operating free-air temperature range (unless otherwise noted)⁽¹⁾

		MIN	MAX	UNIT
Unregulated input voltage, $V_{(driver)}$ ⁽²⁾		-0.5	40	V
Unregulated inputs, $V_{(AIN)}$, $V_{(ENABLE)}$ ⁽²⁾		-0.5	40	V
Bootstrap voltages	$V_{(Cboot1)}$		52	V
	$V_{(Cboot2)}$		14	V
Switch mode voltages	$V_{(L1)}$	-1	40	V
	$V_{(L2)}$	-1	7	V
Logic input voltages, $V_{(Rmod)}$, $V_{(SCR0)}$, $V_{(SCR1)}$, $V_{(CLP)}$, and $V_{(5Vg_ENABLE)}$ ⁽²⁾		-0.5	7	V
Low output voltages, $V_{(RESET)}$, $V_{(AOUT)}$, $V_{(logic)}$, and $V_{(REST)}$ ⁽²⁾		-0.5	7	V
Continuous power dissipation, P_D		See Dissipation Rating		
Operating virtual junction temperature range, T_J		-40	150	°C
Operating ambient temperature range, T_A		-40	125	°C
Lead temperature (soldering, 10 s), $T_{(LEAD)}$			260	°C
Storage temperature, T_{stg}		-65	125	°C

- (1) Stresses beyond those listed under Absolute Maximum Ratings may cause permanent damage to the device. These are stress ratings only, and functional operation of the device at these or any other conditions beyond those indicated under [Recommended Operating Conditions](#) is not implied. Exposure to absolute-maximum-rated conditions for extended periods may affect device reliability.
- (2) All voltage values are with respect to ground.

6.2 ESD Ratings

			VALUE	UNIT
$V_{(ESD)}$ Electrostatic discharge	Human body model (HBM), per JEDEC	Pin 7 (L2), pin 8 (V_{OUT}), Pin 9 (5Vg)	±800	V
		Pins 1–6 and 10–20	±2000	
	Charged device model (CDM), per JEDEC	Corner pins (SCR1, A_{IN} , SCR0, and CLP)	±750	
		Other pins	±750	

6.3 Recommended Operating Conditions

		MIN	NOM	MAX	UNIT
Unregulated input voltage, $V_{(driver)}$		6		24	V
Unregulated input voltages, $V_{(AIN)}$ and $V_{(ENABLE)}$		0		24	V
Switch-mode pins	$V_{(L1)}$	-1		17	V
	$V_{(L2)}$	5		5.5	
Bootstrap voltages	$V_{(Cboot1)}$			$V_{(driver)} + 10$	V
	$V_{(Cboot2)}$			8	
Logic levels (I/O), $V_{(Rmod)}$, $V_{(logic)}$, $V_{(SCR0)}$, $V_{(SCR1)}$, $V_{(5Vg_ENABLE)}$, $V_{(RESET)}$, $V_{(AOUT)}$, $V_{(CLP)}$, and $V_{(REST)}$		0		5.25	V
Operating ambient temperature range, T_A		-40		125	°C
Logic levels (I/O), $V_{(SCR0)}$, $V_{(SCR1)}$, $V_{(CLP)}$ directly connected to $V_{(logic)}$		$V_{(logic)}$		$V_{(logic)}$	V

6.4 Thermal Information

THERMAL METRIC ⁽¹⁾		TPIC74101-Q1	UNIT
		PWP	
		20 PINS	
R _{θJA} ⁽²⁾	Junction-to-ambient thermal resistance	32	°C/W
R _{θJA} ⁽³⁾	Junction-to-ambient thermal resistance	37.9	
R _{θJC(top)}	Junction-to-case (top) thermal resistance	22.7	
R _{θJB}	Junction-to-board thermal resistance	20.2	
ψ _{JT}	Junction-to-top characterization parameter	0.7	
ψ _{JB}	Junction-to-board characterization parameter	19.9	
R _{θJC(bot)}	Junction-to-case (bottom) thermal resistance	1.8	

- (1) For more information about traditional and new thermal metrics, see the *IC Package Thermal Metrics* application report, [SPRA953](#).
(2) The thermal data is based on using 2-oz copper trace with at least four square inches of copper footprint for heat dissipation. The copper pad is soldered to the thermal land pattern. Correct attachment procedure must be incorporated.
(3) The thermal data is based on using 1-oz copper trace with at least four square inches of copper footprint for heat dissipation. The copper pad is soldered to the thermal land pattern. Correct attachment procedure must be incorporated.

6.5 Dissipation Rating

R _{θJA}	T _A ≤ 25°C POWER RATING	DERATING FACTOR ABOVE T _A = 25°C	T _A = 85°C POWER RATING	T _A = 125°C POWER RATING
32°C/W	3.9 W	31.25 mW/°C	2.03 W	0.781 W
40°C/W	3.125 W	25 mW/°C	1.625 W	0.625 W

6.6 Electrical Characteristics

V_(driver) = 6 V to 17 V, T_A = -40°C to 125°C, unless otherwise noted

PARAMETERS		TEST CONDITIONS	MIN	TYP	MAX	UNIT
V _(driver)	Unregulated input voltage		1.5		40	V
V _(driver)	Start-up condition voltage	I _O = 600 mA			5	V
S _{OM}	Soft-start ramp	C _O = 36 μF (min) to 220 μF (max)	4		20	V/ms
		C _O = 220 μF (min) to 470 μF (max) ⁽¹⁾	2		20	
I _(standby)	Standby current	ENABLE = low		10	20	μA
I _q	Quiescent current	CLP = 0 V, V _(driver) = 11 V, I _O = 0 mA		110	160	μA
V _O	Output voltage	DC		5		V
V _O	Output-voltage tolerance	Buck mode			2%	
		Low-Power or Boost or Boost/buck crossover mode			3%	
I _O	Output current	V _(driver) ≥ 7 V			1	A
I _{O(Boost)}	Output current, boost mode	V _(driver) = 2 V, see Note ⁽²⁾			200	mA
		V _(driver) = 1.5 V, see Note ⁽²⁾			120	
I _{PPn}	Internal peak current limit (normal mode)	⁽¹⁾	1.75		2.5	A
I _{PPI}	Internal peak current limit (low-power mode)	⁽¹⁾	0.75		1.25	A
I _P	Peak current	V _(driver) = 16 V, I _O = 1 A, and L = 33 μH		1.5		A
V _(driver)	Boost/buck crossover voltage window	See Note ⁽³⁾	5		5.9	V
T _{ot}	Thermal shutdown ⁽⁴⁾		160	180	200	°C

- (1) Ensured by characterization
(2) Tested with inductor having following characteristics: L = 33 μH, R_{max} = 0.1 Ω, I_R = 1.8 A. Output current must be verified in application when inductor R_{max} (ESR) is increased.
(3) Ensured by characterization. For further details, see the [Buck/Boost Transitioning](#) section.
(4) Ensured by characterization; hysteresis 15°C (typical)

Electrical Characteristics (continued)
 $V_{(driver)} = 6\text{ V to }17\text{ V}$, $T_A = -40^\circ\text{C to }125^\circ\text{C}$, unless otherwise noted

PARAMETERS		TEST CONDITIONS	MIN	TYP	MAX	UNIT
5Vg OUTPUT AND ENABLE						
$r_{DS(on)}$	On-state resistance			140	225	m Ω
I_O	Output current				400	mA
V_I	5Vg_ENABLE input-voltage range		-0.5		V_O	V
V_{IH}	5Vg_ENABLE threshold high voltage	$V_{(5Vg)} = 5\text{ V}$	2.5	3	3.5	V
V_{IL}	5Vg_ENABLE threshold low voltage	$V_{(5Vg)} = 0\text{ V}$	1.5	2	2.5	V
$V_{(hys)}$	Hysteresis voltage		0.5	1		V
$r_{(pd)}$	Internal pulldown resistor		300	500	850	k Ω
ENABLE						
V_I	ENABLE input-voltage range		-0.5		40	V
V_{IH}	ENABLE threshold high voltage	$8\text{ V} \leq V_{(driver)} \leq 17\text{ V}$	2.5	3	3.5	V
		$6\text{ V} \leq V_{(driver)} < 8\text{ V}$	1.9	2.5	3.5	
V_{IL}	ENABLE threshold low voltage	$V_O = 5\text{ V}$	1.5	1.85	2.5	V
$V_{(hys)}$	Hysteresis voltage	$8\text{ V} \leq V_{(driver)} \leq 17\text{ V}$	0.5	1		V
		$6\text{ V} \leq V_{(driver)} < 8\text{ V}$	0.1			
RESET						
$V_{(th)}$	RESET threshold voltage		4.51	4.65	4.79	V
$V_{(RESET)}$	RESET tolerance				3%	
$t_{(RESET)}$	RESET time	$C_{(REST)} = 10\text{ nF}$	8	10	12	ms
		$C_{(REST)} = 100\text{ nF}$, see Note ⁽¹⁾	80	100	120	
V_{OL}	RESET output low voltage	$I_{sink} = 5\text{ mA}$			450	mV
		$I_{sink} = 1\text{ mA}$			84	
$t_{(deglitch)}$	RESET deglitch time	See Note ⁽¹⁾	8	10	12.5	μs
ALARM						
V_I	Alarm input-voltage range		-0.5		40	V
V_{IL}	Alarm threshold low voltage		2.2	2.3	2.35	V
V_{IH}	Alarm threshold high voltage		2.43	2.5	2.58	V
$V_{(hys)}$	Hysteresis voltage			240		mV
V_{OL}	Alarm output low voltage	$I_{sink} = 5\text{ mA}$			450	mV
		$I_{sink} = 1\text{ mA}$			84	
LOW-POWER MODE (PULSE MODE) PFM						
$I_{O(LPM)}$	Load current in low-power mode	$V_{(driver)} < 7\text{ V}$			50	mA
$I_{I(av)}$	Average input current	$V_{(driver)} = 11\text{ V}$, $I_O = 5\text{ mA}$, CLP = low			3.55	mA
V_O	Output-voltage tolerance	$V_O = 5\text{ V}$		2.4%	3%	
DIGITAL LOW-POWER MODE (CLP)						
V_{IH}	High-level CLP input threshold voltage	Normal mode	2.6			V
V_{IL}	Low-level CLP input threshold voltage	Low-power mode			1.15	V
SWITCHING PARAMETERS						
$f_{(sw)}$	Switching frequency	$V_{(Rmod)} = 0\text{ V}$, modulator OFF		380		kHz
$f_{(sw)ac}$	Operating-frequency accuracy	$f_{(sw)} = 380\text{ kHz}$			20%	
$f_{(sw)min}$	Modulation minimum frequency		230	285	385	kHz
$f_{(sw)max}$	Modulation maximum frequency		390	480	590	kHz
$f_{(mod)span}$	Modulation span			220		kHz
$f_{(mod)}$	Modulation frequency	$R_{mod} = 12\text{ k}\Omega \pm 1\%$		28		kHz
$f_{(mod)ac}$	Modulation-frequency accuracy				12%	

6.7 Typical Characteristics

(Reference L1 Pin, see Figure 10 through Figure 12)

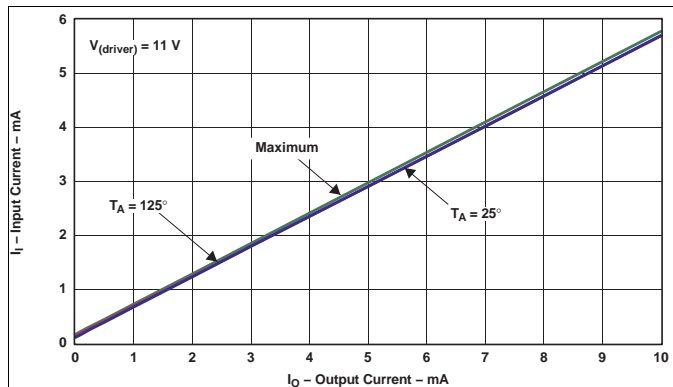

Maximum characteristic specified by design.
 $I_O = 0 \text{ mA} - 10 \text{ mA}$

Figure 1. Low-Power Mode Current

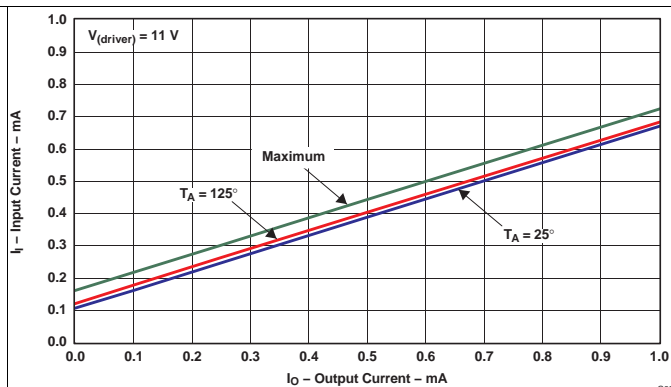

Maximum characteristic specified by design.
 $I_O = 0 \text{ mA} - 1 \text{ mA}$

Figure 2. Low-Power-Mode Current

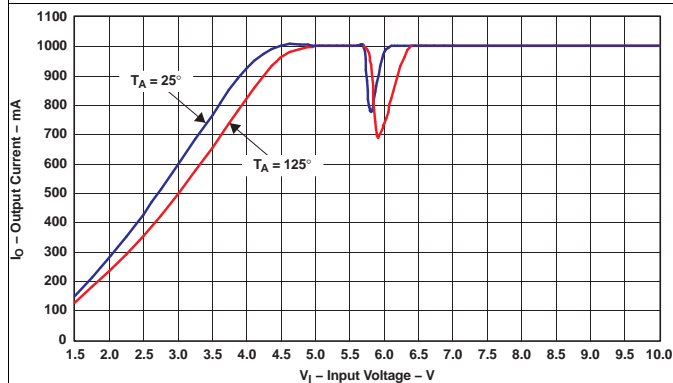

(1) Typical representation of input voltage vs output load current at $T_A = 25^\circ\text{C}$ and 125°C , after the correct power-up sequence is invoked.
 (2) The dip in the output current at 5.8 V is caused by the buck/boost transition of the IC.
 (3) The output current is clipped to 1 A by the measurement setup.

Figure 3. Typical Input Voltage ($V_{(driver)}$) vs Maximum Output Load Current (I_O)

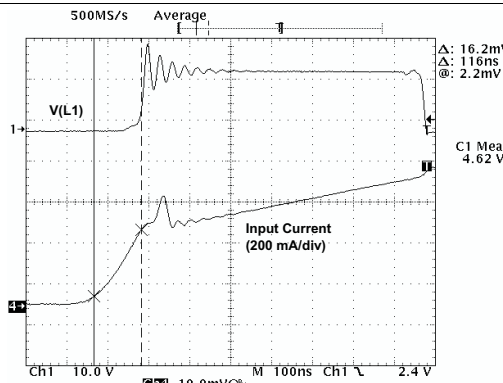

SCR0 = 0, SCR1 = 0, Input-Current Slew Rate = 2.8 A/ μs ,
 $I_L = 500 \text{ mA}$, $V_{(driver)} = 15 \text{ V}$

Figure 4. Input Current With Slope Control

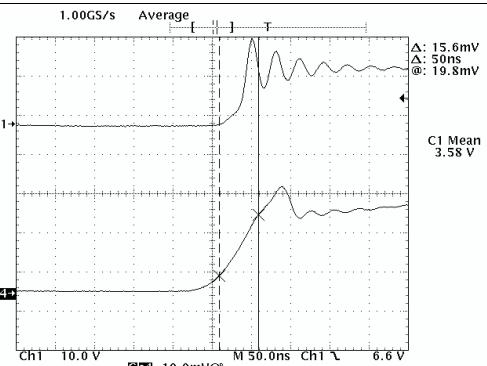

SCR1 = 0, SCR0 = 1, Input-Current Slew Rate = 6.25 A/ μs ,
 $I_L = 500 \text{ mA}$, $V_{(driver)} = 15 \text{ V}$

Figure 5. Input Current With Slope Control

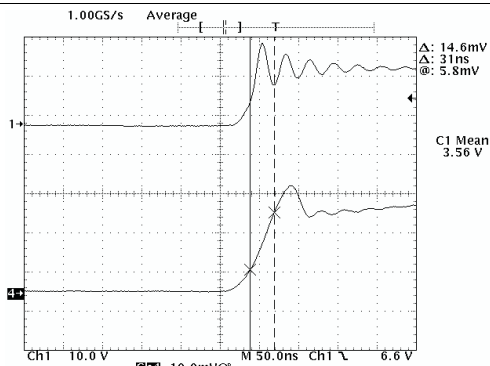

SCR1 = 1, SCR0 = 0, Input-Current Slew Rate = 9.4 A/ μs ,
 $I_L = 500 \text{ mA}$, $V_{(driver)} = 15 \text{ V}$

Figure 6. Input Current With Slope Control

Typical Characteristics (continued)

(Reference L1 Pin, see Figure 10 through Figure 12)

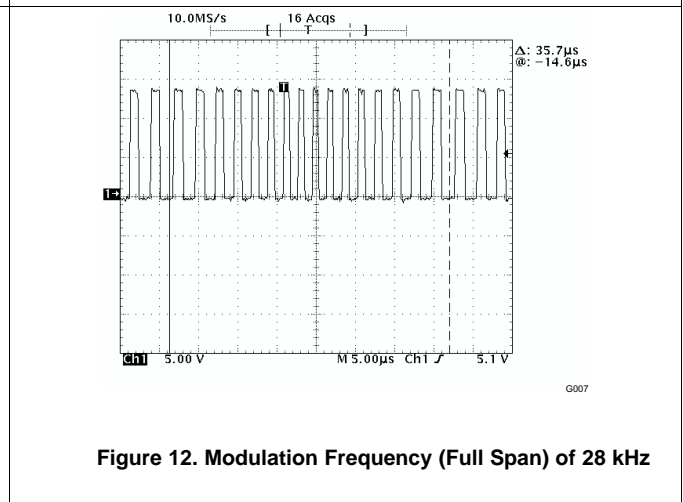
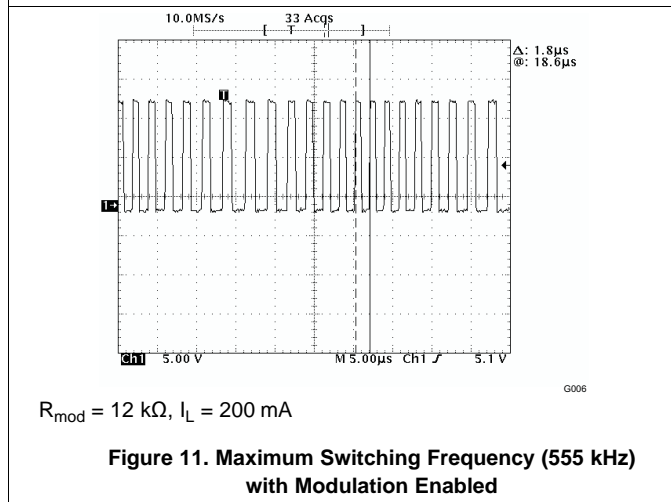
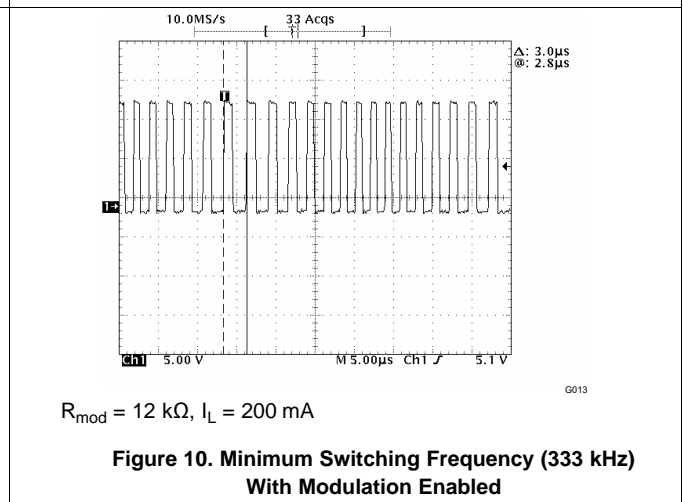
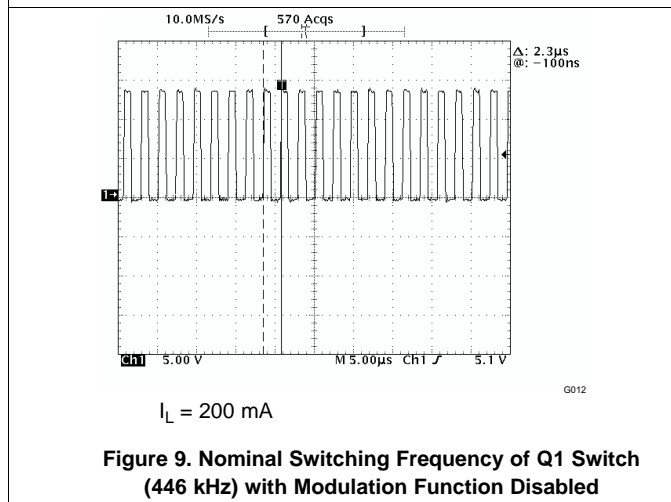
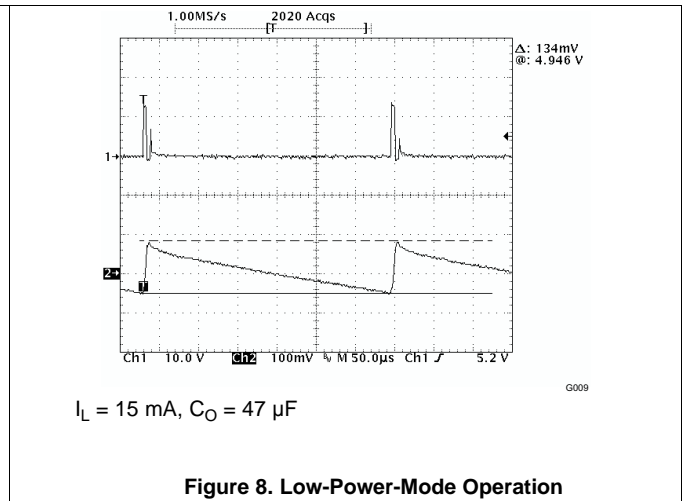
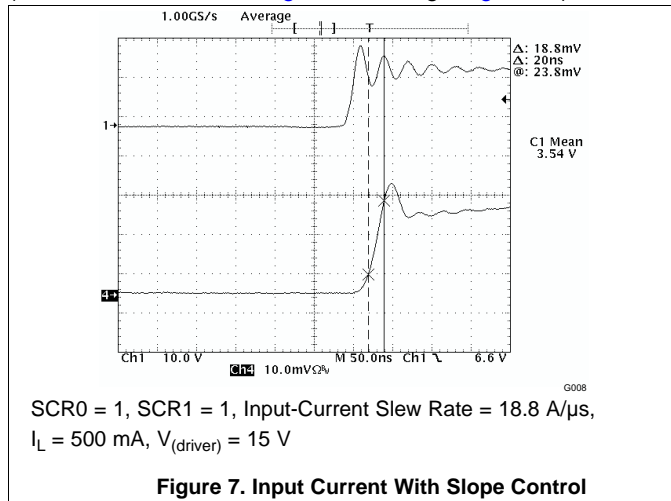

Typical Characteristics (continued)

(Reference L1 Pin, see Figure 10 through Figure 12)

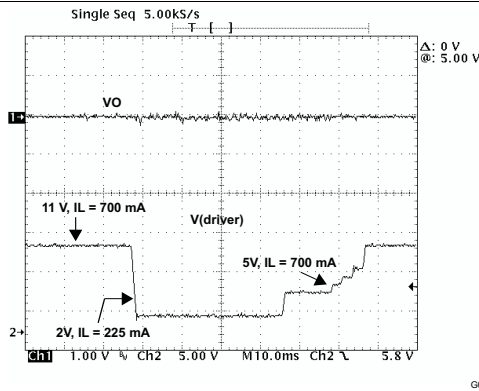
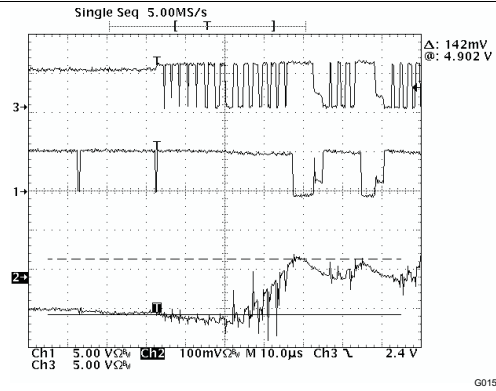
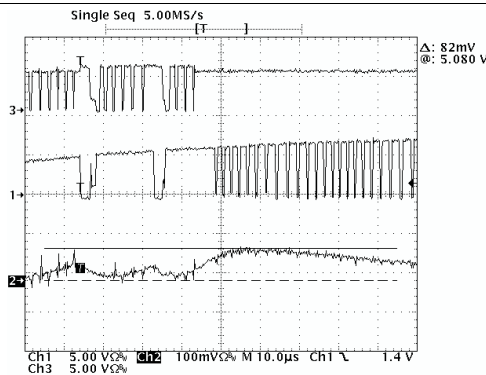

Figure 13. Input Voltage Excursions (Similar to Low-Crank Conditions)



$I_L = 400 \text{ mA}$

Figure 14. Switch-Mode Regulator Transition From Buck Mode to Boost Mode



$I_L = 400 \text{ mA}$

Figure 15. Switch-Mode Regulator Transition From Boost Mode to Buck Mode

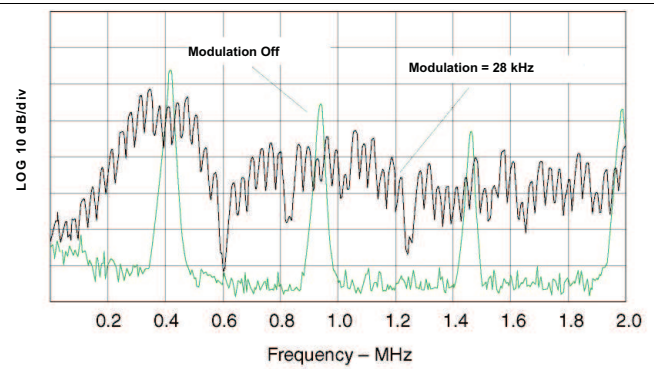

These values represent conducted EMI results of a test board for display purposes only. Actual results may vary greatly depending on board layout and external components and must be verified in actual application

Figure 16. Conducted Emissions on Test Board Showing Effects of Switching-Frequency Modulation

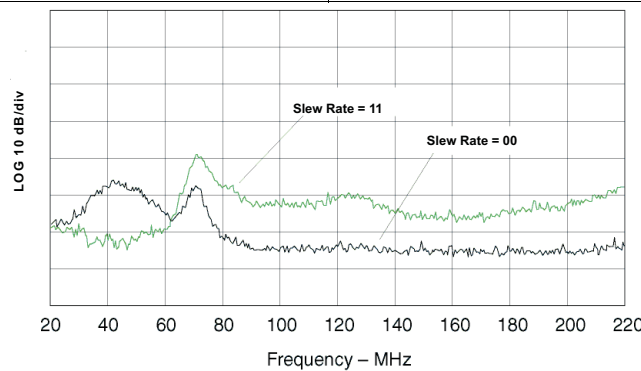

These values represent conducted EMI results of a test board for display purposes only. Actual results may vary greatly depending on board layout and external components and must be verified in actual application.

Figure 17. Conducted Emissions on Test Board Showing Effects of Minimum and Maximum Slew Rate Settings

7 Detailed Description

7.1 Overview

The TPIC74101-Q1 is a buck/boost switch-mode regulator that operates in a power-supply concept to ensure a stable output voltage with input voltage excursions and specified load range.

The device provides an alarm indicator and reset output to interface with systems that require supervisory function.

The switching regulator offers a clock modulator and a current-mode slew-rate control for the internal switching transistor (Q1) to minimize EMI.

An internal low- $r_{DS(on)}$ switch has a current-limit feature to prevent inadvertent reset when turning on the 5Vg output.

7.2 Functional Block Diagram

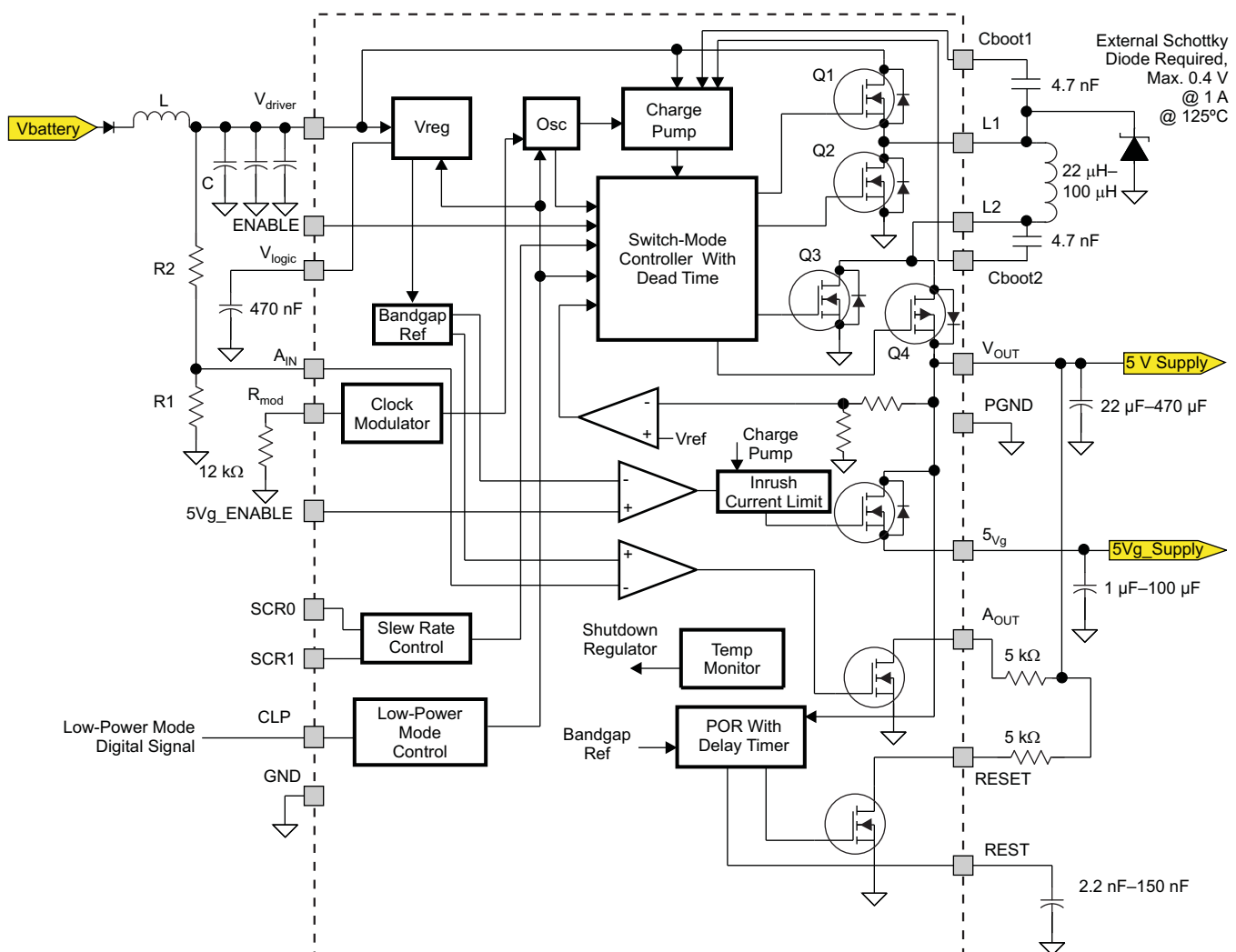

B0130-01

NOTE: All component values are typical.

7.3 Feature Description

7.3.1 Switch-Mode Input/Output Pins (L1, L2)

The external inductor for the switch-mode regulator is connected between pins L1 and L2. This inductor is placed close to the pins to minimize parasitic effects. For stability, an inductor with 20 μH to 100 μH should be used.

7.3.2 Supply Pin (V_{driver})

The input voltage of the device is connected to the V_{driver} pin. This input line requires a filter capacitor to minimize noise. A low-ESR aluminum or tantalum input capacitor is recommended. The relevant parameters for the input capacitor are the voltage rating and RMS current rating. The voltage rating should be approximately 1.5 times the maximum applied voltage for an aluminum capacitor and 2 times for a tantalum capacitor. In buck mode, the RMS current is $I_{\text{OUT}} \times \sqrt{D - D^2}$, where D is the duty cycle and its maximum RMS current value is reached when $D = 50\%$ with $I_{\text{RMS}} = I_{\text{OUT}}/2$. In boost mode, the RMS current is $0.3 \times \Delta I$, where ΔI is the peak-to-peak ripple current in the inductor. To achieve this, ESR ceramic capacitors are used in parallel with the aluminum or tantalum capacitors.

7.3.3 Internal Supply Decoupling Pin (V_{logic})

The V_{logic} pin is used to decouple the internal power-supply noise by use of a 470-nF capacitor. This pin can also be used as an output supply for the logic-level inputs for this device (SCR0, SCR1, ENABLE, CLP, and 5Vg_ENABLE).

7.3.4 Input Voltage Monitoring Pin (A_{IN})

The A_{IN} pin is used to program the threshold voltage for monitoring and detecting undervoltage conditions on the input supply. A maximum of 40 V may be applied to this pin and the voltage at this pin may exceed the V_{driver} input voltage without effecting the device operation. The resistor divider network is programmed to set the undervoltage detection threshold on this pin (see the application schematic). The input has a typical hysteresis of 200 mV with a typical upper limit threshold of 2.5 V and a typical lower limit threshold of 2.3 V. When V_{AIN} falls below 2.3 V, V_{AOUT} is asserted low; when V_{AIN} exceeds 2.5 V, V_{AOUT} is in the high-impedance state.

The equations to set the upper and lower thresholds of V_{AIN} are:

Upper:

$$V_{\text{driver}} = 2.5 \text{ V} \times \frac{R1 + R2}{R1}$$

Lower:

$$V_{\text{driver}} = 2.3 \text{ V} \times \frac{R1 + R2}{R1}$$

(1)

7.3.5 Input Undervoltage Alarm Pin (A_{OUT})

The A_{OUT} pin is an open-drain output that asserts low when the input voltage falls below the set threshold on the A_{IN} input.

7.3.6 Reset Delay Timer Pin (REST)

The REST pin sets the desired delay time to assert the RESET pin low after the 5-V supply has exceeded 4.65 V (typical). The delay can be programmed in the range of 2.2 ms to 150 ms using capacitors in the range of 2.2 nF to 150 nF. The delay time is calculated using the following equation:

$$\text{RESET delay} = C_{\text{REST}} \times 1 \text{ ms, where } C_{\text{REST}} \text{ has nF units}$$

7.3.7 Reset Pin (RESET)

The RESET pin is an open-drain output. The power-on reset output is asserted low until the output voltage exceeds the 4.65-V threshold and the reset delay timer has expired. Additionally, whenever the ENABLE pin is low, RESET is immediately asserted low regardless of the output voltage.

Feature Description (continued)

7.3.8 Main Regulator Output Pin (V_{OUT})

The V_{OUT} pin is the output of the switch-mode regulated supply. This pin requires a filter capacitor with low-ESR characteristics to minimize output ripple voltage. For stability, a capacitor with 22 μF to 470 μF should be used. The total capacitance at pin V_{OUT} and pin 5Vg must be less than or equal to 470 μF .

7.3.9 Low-Power-Mode Pin (CLP)

The CLP pin controls the low-power mode of the device. An external low digital signal switches the device to low-power mode or normal mode when the input is high.

7.3.10 Switch-Output Pin (5Vg)

The 5Vg pin switches the 5-V regulated output. The output voltage of the regulator can be enabled or disabled using this low- $r_{DS(on)}$ internal switch. This switch has a current-limiting function to prevent generation of a reset signal at turnon caused by the capacitive load on the output or overload condition. When the switch is enabled, the regulated output may deviate and drop momentarily to a tolerance of 7% until the 5Vg capacitor is fully charged. This deviation depends on the characteristics of the capacitors on V_{OUT} and 5Vg.

7.3.11 5Vg-Enable Pin (5Vg_ENABLE)

The 5Vg_ENABLE is a logic-level input for enabling the switch output on 5Vg.

For the functional pin, 5Vg_ENABLE results in [Table 1](#):

Table 1. 5Vg_ENABLE, Functional Pin

5Vg_ENABLE	FUNCTION
0	5Vg is off
Open (internal pulldown = 500 k Ω)	5Vg is off
1	5Vg is on

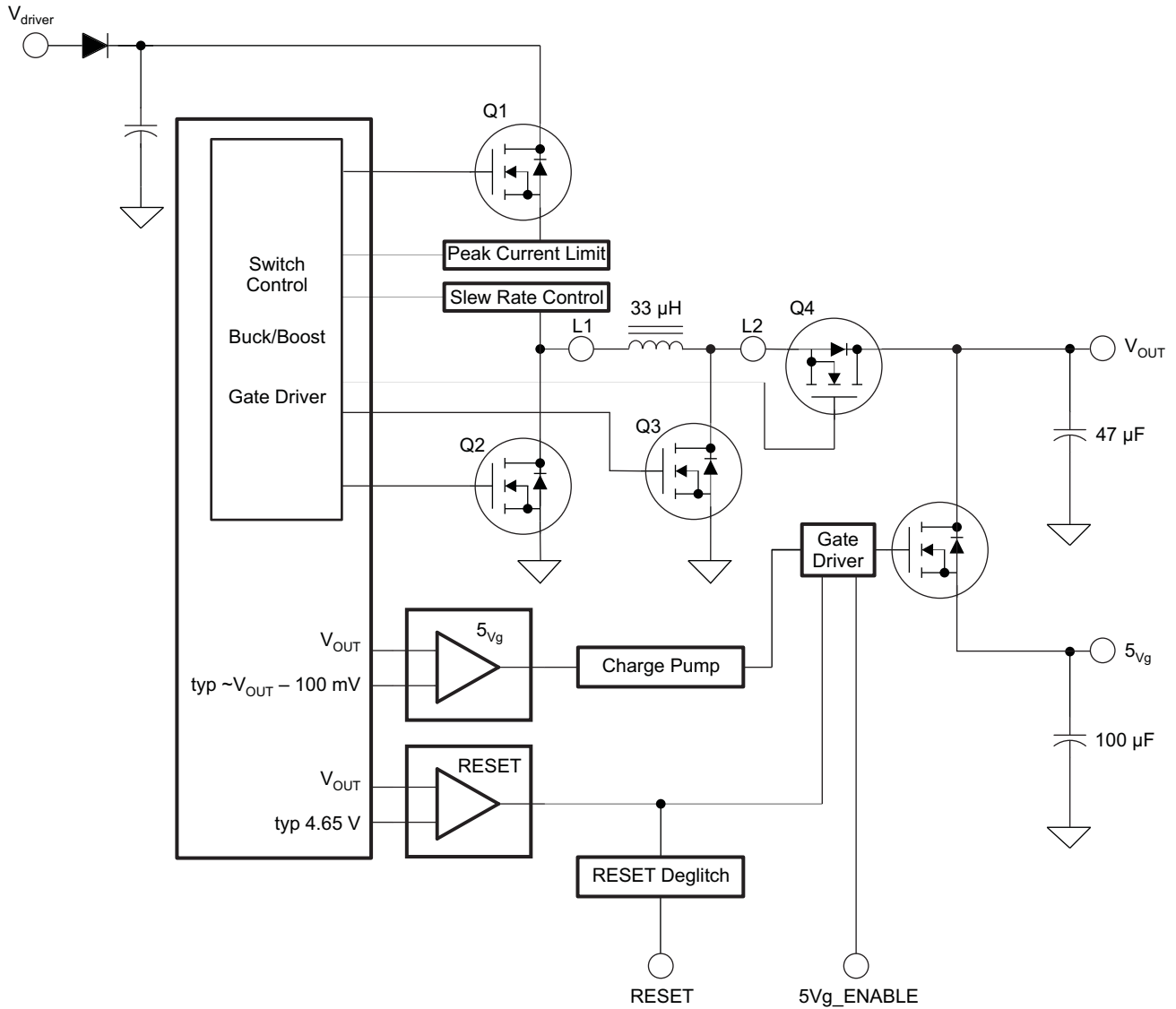

S0174-01

Figure 18. Current-Limit Switched Output 5Vg

7.3.12 Slew-Rate Control Pins (SCR0, SCR1)

The slew rate of the switching transistor Q1 is set using the SCR0 and SCR1 pins.

Table 2 shows the values of the slew rate (SR):

Table 2. Slew Rate Values (SR)

SCR1	SCR0	SR _{Q1}
0	0	Slow
0	1	Medium-slow
1	0	Medium-fast
1	1	Fast

See the converter efficiency plots in the *Typical Characteristics* section to determine power dissipation.

7.3.13 Modulator Frequency Setting (Pin R_{mod})

The R_{mod} pin adjusts the clock modulator frequency. A resistor of R_{mod} = 12 kΩ generates a modulation frequency of 28 kHz. The modulator function may be disabled by connecting R_{mod} to GND and the device operates with the nominal frequency. The modulator function cannot be activated during IC operation, only at IC start-up.

7.3.14 Ground Pin (PGND)

The PGND pin is the power ground for the device.

7.3.15 Enable Pin (ENABLE)

The ENABLE pin allows the enabling and disabling of the switch mode regulator. A maximum of 40 V may be applied to this pin to enable the device and increasing it above the V_(driver) input voltage does not affect the device operation.

Table 3 describes the functionality of the ENABLE pin.

Table 3. Functionality of the ENABLE Pin

ENABLE	FUNCTION
0	Vreg is off.
Open	Undefined
1	Vreg is on.

7.3.16 Bootstrap Pins (Cboot1 and Cboot2)

An external bootstrap capacitor is required for driving the internal high-side MOSFET switch. A 4.7-nF ceramic capacitor is typically required.

7.4 Device Functional Modes

7.4.1 Clock Modulator

To minimize EMI issues associated with the switch-mode regulator, the device offers an integrated clock modulator. The function of the clock modulator is to modulate the switching frequency and to distribute the energy over the wave band.

The average switching frequency is 380 kHz (typical) and varies between 285 kHz and 480 kHz at a rate set by the R_{mod} resistor. A typical value of 12 kΩ on the R_{mod} pin relates to a 28-kHz modulation frequency. The clock modulator function can only be activated during IC start-up, not during IC operation.

Equation 2 is for the modulation frequency.

$$f_{(\text{mod})} (\text{Hz}) = (-2.2 \times R_{\text{mod}}) + 54.5 \text{ kHz}, \quad (2)$$

when R_{mod} = 8 kΩ to 16 kΩ. Bigger resistor values like 100 kΩ are also allowed for Rmod.

7.4.2 Buck/Boost Transitioning

The operation mode switches automatically between buck and boost modes depending on the input voltage of V_(driver) and output load conditions. During start up, when V_(driver) is less than 5.8 V (typical), the device starts in boost mode and continues to run in boost mode until V_(driver) exceeds 5.8 V; at which time, the device switches over to buck mode. In buck mode, the device continues to run in buck mode until it is required to switch back to boost to hold regulation. This crossover window to switch to boost mode is when V_(driver) is between 5.8 V and 5 V and depends on the loading conditions. When V_{driver} drops below 5.8 V but the device is holding regulation (~2%), the device remains in buck mode. However, when V_(driver) is within the 5.8-V to 5-V window and V_{OUT} drops to 4.9 V, the device crosses over to boost mode to hold regulation. In boost mode, the device remains in

Device Functional Modes (continued)

boost mode until $V_{(driver)}$ exceeds 5.8 V; at which time, the device enters the buck mode. When the device is operating in boost mode and $V_{(driver)}$ is in the crossover window of 5.8 V to 5 V, the output regulation may contain a higher than normal ripple and only maintain a 3% tolerance. This ripple and tolerance depends on the loading and improves with a higher loading condition. When the device is operated with low-power mode active (CLP = low) and high output currents (>50 mA), the buck/boost transitioning can cause a reset signal at the RESET pin.

7.4.3 Buck SMPS

In buck mode, the duty cycle of transistor Q1 sets the voltage V_{OUT} . The duty cycle of transistor Q1 varies 10% to 99% depending on the input voltage, $V_{(driver)}$. If the peak inductor current (measured by Q1) exceeds 450 mA (typical), Q2 is turned on for this cycle (synchronized rectification). Otherwise, the current recirculates through Q2 as a free-wheeling diode. The detection for synchronous or asynchronous mode is done cycle-by-cycle.

To avoid a cross-conduction current between Q1 and Q2, an inherent delay is incorporated when switching Q1 off and Q2 on and vice versa.

In buck mode, transistor Q3 is not required and is switched off. Transistor Q4 is switched on to reduce power dissipation.

The switch timings for transistors Q3 and Q4 are not considered. In buck mode, the logical control of the transistors does not change.

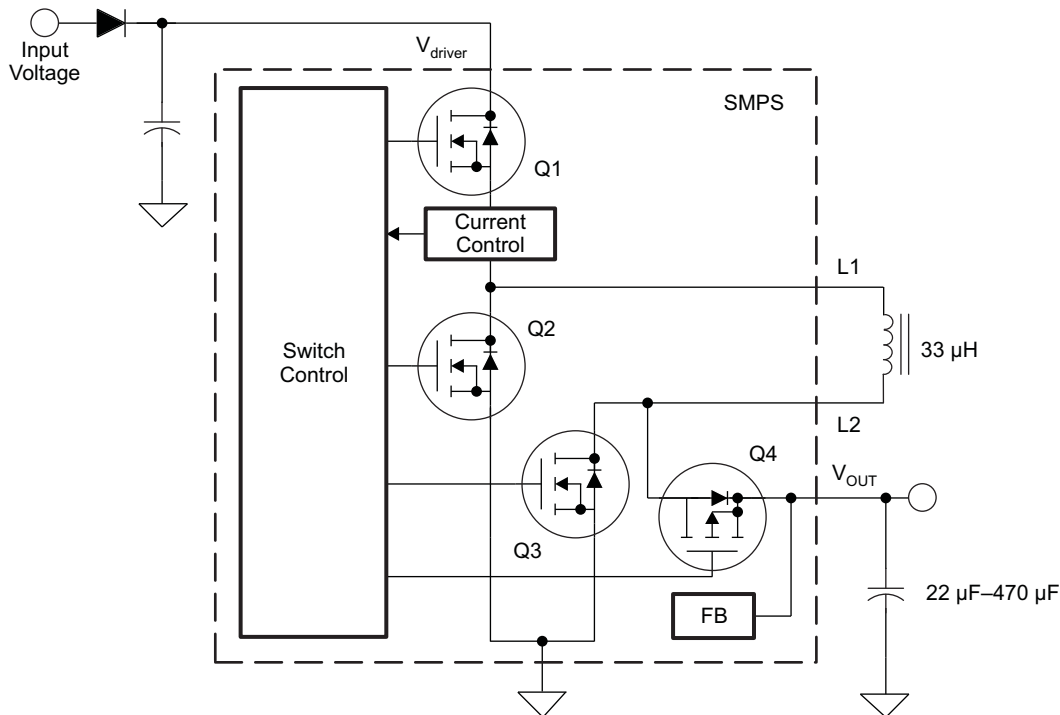

Figure 19. Buck/Boost Switch Mode Configuration

7.4.4 Boost SMPS

In boost mode, the duty cycle of transistor Q3 controls the output voltage V_{OUT} . The duty cycle is internally adjusted 5% to 85% depending on the internally sensed voltage of the output. Synchronized rectification occurs when $V_{(driver)}$ is below 5 V.

To avoid a discharging of the buffer capacitor, a simultaneous switching on of Q3 and Q4 is not allowed. An inherent delay is incorporated between Q3 switching off and Q4 switching on and vice versa.

In boost mode, transistor Q2 is not required and remains off. Transistor Q1 is switched on for the duration of the boost-mode operation (serves as a supply line).

Device Functional Modes (continued)

The switch timings of transistors Q1 and Q2 are not considered. In boost mode, the logical control of the transistors does not change.

7.4.5 Extension of the Input Voltage Range on $V_{(driver)}$

To ensure a stable 5-V output voltage with the output load in the specified range, the $V_{(driver)}$ supply must be greater than or equal to 5 V for greater than 1 ms (typical). After a period of 1 ms (typical), the logic may be supplied by the V_{OUT} regulator and the $V_{(driver)}$ supply may be capable of operating down to 1.5 V.

The switch-mode regulator does not start at $V_{(driver)}$ less than 5 V.

7.4.6 Low-Power Mode

To reduce quiescent current and to provide efficient operation, the regulator enters a pulsed mode.

The device enters this mode by a logic-level low on this pin.

Automatic low-power mode is not available. The low-power-mode function is not available in boost mode. The device leaves low-power mode during boost mode regardless of the logic level on the CLP pin.

7.4.7 Temperature and Short-Circuit Protection

To prevent thermal destruction, the device offers overtemperature protection to disable the IC. Also, short-circuit protection is included for added protection on V_{OUT} and 5Vg.

7.4.8 Switch Output Pin (5Vg) Current Limitation

A charge pump drives the internal FET, which switches the primary output voltage V_{OUT} to the 5Vg pin. Protection is implemented to prevent the output voltage from dropping below its specified value while enabling the secondary output voltage. An explanation of the block diagram (see Figure 1) is given by the following example:

- Device is enabled, output voltage V_{OUT} is up and stable.
- 5Vg is enabled (pin 5Vg_ENABLE set to high) with load resistance connected to 5Vg pin.
- If output voltage V_{OUT} drops below typical ($V_{OUT} - 100$ mV), the charge pump of the 5Vg FET is switched off and the FET remains on for a while as the gate voltage drops slowly.
- If V_{OUT} drops below the RESET threshold of 4.65 V (typical), the FET of the secondary output voltage 5Vg is switched off (gate drawn to ground level).
- A deglitch time ensures that a device reset does not occur if V_{OUT} drops to the reset level during the 5Vg turnon phase.
- If V_{OUT} rises above typical ($V_{OUT} - 100$ mV), the charge pump of the 5Vg FET is switched on and drives the gate of the 5Vg FET on.

7.4.9 Soft Start

On power up, the device offers a soft-start feature which ramps the output of the regulator at a slew of 10 V/ms. When a reset occurs, the soft start is reenabled. Additionally, if the output capacitor is greater than 220 μ F (typical), the slew rate decreases to a value set by the internal current limit. In boost mode, the soft-start feature is not active.

8 Application and Implementation

NOTE

Information in the following applications sections is not part of the TI component specification, and TI does not warrant its accuracy or completeness. TI's customers are responsible for determining suitability of components for their purposes. Customers should validate and test their design implementation to confirm system functionality.

8.1 Application Information

The TPIC74100-Q1 is a switch-mode regulator with integrated switches for voltage-mode control. With the help of external LC components, the device regulates the output to 5V +2% for a wide input voltage range. The device can monitor the output voltage as well as the input voltage.

8.2 Typical Application

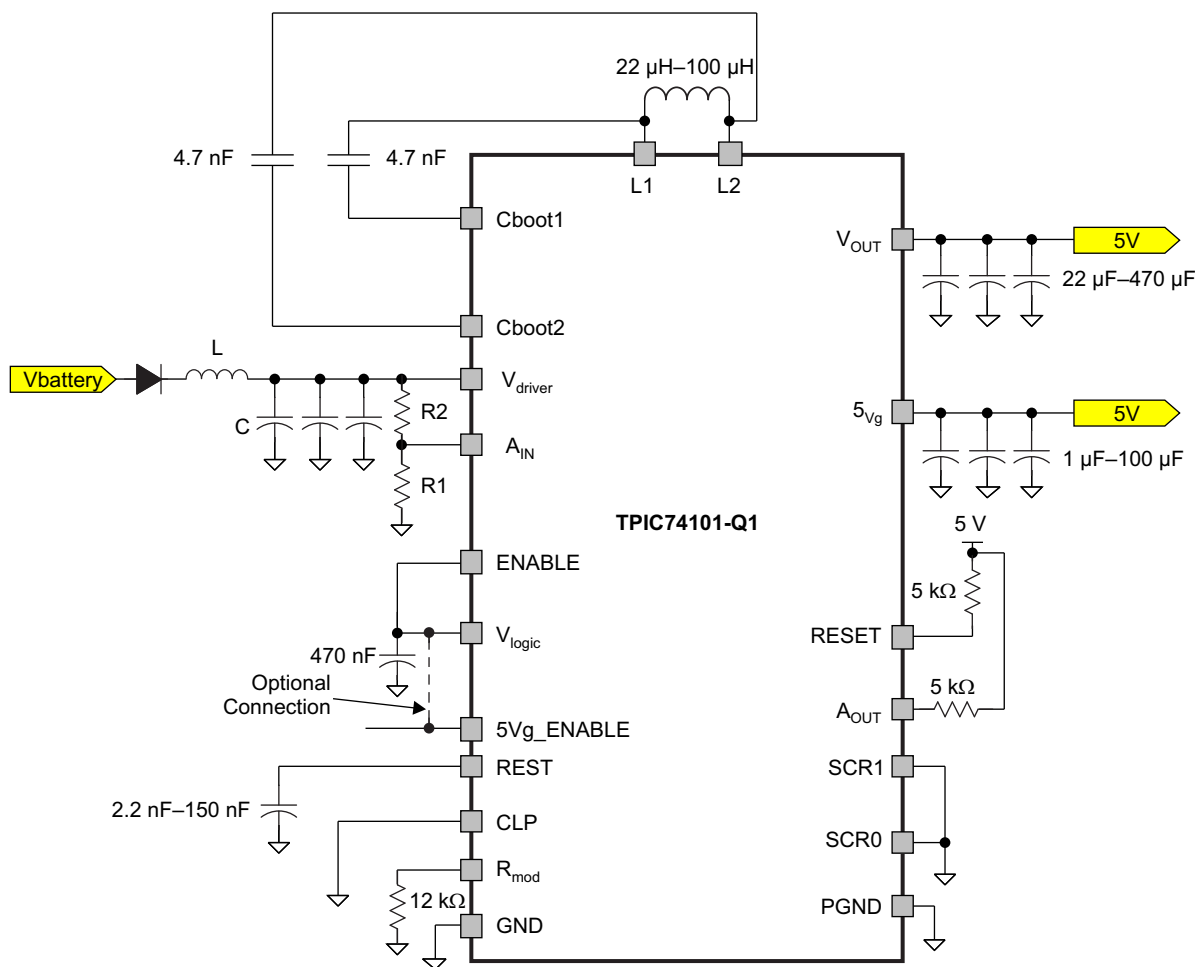

S0183-01

- A. To minimize voltage ripple on the output due to transients, it is recommended to use a low-ESR capacitor on the V_{OUT} line.
- B. The L and C component values are system application dependent for EMI consideration.

Figure 20. Application Schematic

8.2.1 Design Requirements

Plot the converter efficiency with four different slew rate controls (SCRx) at an input voltage of 11 V and 17 V. The slew rate of the switching transistor Q1 can be changed using the SCR0 and SCR1 pins.

Typical Application (continued)

8.2.2 Detailed Design Procedure

8.2.2.1 Buck Mode

- Select inductor ripple current ΔI_L : for example $\Delta I_L = 0.2 \times I_{OUT}$
- Calculate inductor L

$$L = \frac{(V_{IN} - V_{OUT}) \times V_{OUT}}{f_{SW} \times \Delta I_L \times V_{IN}} \quad (H) \quad (3)$$

where f_{SW} is the regulator switching frequency.

- Inductor peak current

$$I_{L,max} = I_{OUT} + \frac{\Delta I_L}{2} \quad (A) \quad (4)$$

- Output voltage ripple

$$\Delta V_{OUT} = \Delta I_L \times \left(ESR + \frac{1}{8 \times f_{SW} \times C_{OUT}} \right) \quad (V_{(p-p)}) \quad (5)$$

Usually, the first term is dominant.

$$C_{OUT} = \frac{I_{pk}(t_{on} + t_{off})}{8 \times V_{ripple}} \quad (F) \quad (6)$$

8.2.2.2 Boost Mode

- Select inductor ripple current ΔI_L : for example $\Delta I_L = 0.2 \times I_{IN}$
- Calculate inductor L

$$L = \frac{(V_{OUT} - V_{IN}) \times V_{IN}}{f_{SW} \times \Delta I_L \times V_{OUT}} \quad (H) \quad (7)$$

where f_{SW} is the regulator switching frequency.

- Inductor peak current

$$I_p = I_{L,max} = I_{IN} + \frac{\Delta I_L}{2} \quad (A) \quad (8)$$

- Output voltage ripple

$$\Delta V_{OUT} = I_p \times ESR + \frac{I_{OUT} \times \left(1 - \frac{V_{IN}}{V_{OUT}} \right)}{f_{SW} \times C_{OUT}} \quad (V_{(p-p)}) \quad (9)$$

Typical Application (continued)

8.2.3 Application Curves

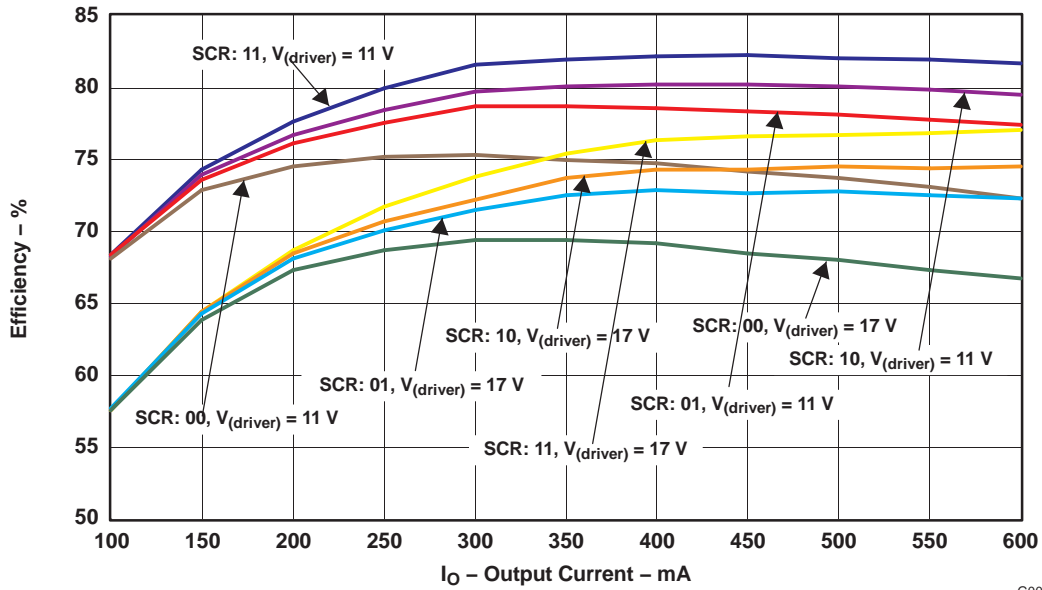

G004

NOTE: The average converter efficiency with four different slew rate controls (SCRx) on the Q1 switching FET with input voltage $V_{(driver)} = 11\text{ V}$ and 17 V , $T_A = 125^\circ\text{C}$.

Figure 21. Converter Efficiency

9 Power Supply Recommendations

The input decoupling capacitors and bootstrap capacitor must be located as close as possible to the device. Ensure that input power supply is clean. To minimize voltage ripple on the output due to transients, it is recommended to use a low-ESR capacitor on the VOUT line. The L and C component values are system application dependent for EMI consideration. TI recommends using a low EMI Inductor with a ferrite-type closed core.

10 Layout

10.1 Layout Guidelines

10.1.1 Switch-Mode Power Supply

The following guidelines are recommended for PCB layout of the TPIC74100 device.

10.1.1.1 Inductor

Use a low-EMI inductor with a ferrite-type closed core. Other types of inductors may be used; however, they must have low-EMI characteristics and be located away from the low-power traces and components in the circuit.

10.1.1.2 Filter Capacitors

Input ceramic filter capacitors should be located in the close proximity of the V_{driver} pin. Surface-mount capacitors are recommended to minimize lead length and reduce noise coupling.

10.1.1.3 Traces and Ground Plane

All power (high-current) traces should be thick and as short as possible. The inductor and output capacitors should be as close to each other as possible. This reduces EMI radiated by the power traces due to high switching currents.

In a two-sided PCB, it is recommended to have ground planes on both sides of the PCB to help reduce noise and ground-loop errors. The ground connection for the input and output capacitors and IC ground should be connected to this ground plane.

In a multilayer PCB, the ground plane is used to separate the power plane (where high switching currents and components are placed) from the signal plane (where the feedback trace and components are) for improved performance.

Also, arrange the components such that the switching-current loops curl in the same direction. Place the high-current components such that during conduction, the current path is in the same direction. This prevents magnetic field reversal caused by the traces between the two half-cycles, helping to reduce radiated EMI.

10.1.2 Package and PCB Land Configuration for a Multilayer PCB

To maximize the efficiency of this package for application on a single-layer or multilayer PCB, certain guidelines must be followed when laying out this device on the PCB.

The following information is to be used as a guideline only.

For further information see the *PowerPAD Thermally Enhanced Package* technical brief ([SLMA002](#)).

The following are guidelines for mounting the PowerPAD™ IC on a multilayer PCB with a ground plane.

Layout Guidelines (continued)

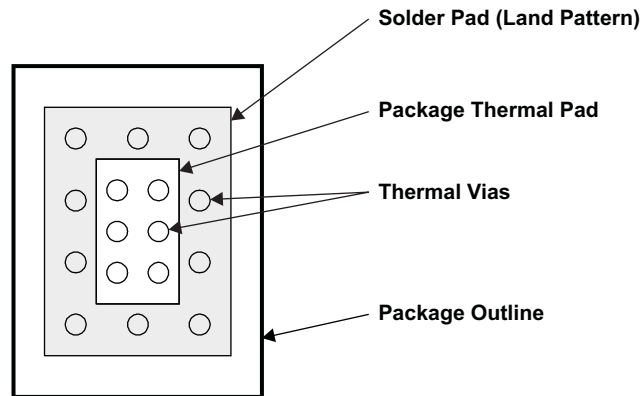

M0026-01

Figure 22. Package and PCB Land Configuration for a Multilayer PCB

10.1.3 Multilayer (Side View)

In a multilayer board application, the thermal vias are the primary method of heat transfer from the package thermal pad to the internal ground plane.

The efficiency of this method depends on several factors (die area, number of thermal vias, thickness of copper, etc.). See the *PowerPAD Thermally Enhanced Package* technical brief (SLMA002).

Layout recommendation is to use as much copper area for the power-management section of a single-layer board as possible. In a single-layer board application, the thermal pad is attached to a heat spreader (copper areas) by using a low-thermal-impedance attachment method (solder paste or thermal-conductive epoxy). In both of these cases, it is advisable to use as much copper and as many traces as possible to dissipate the heat.

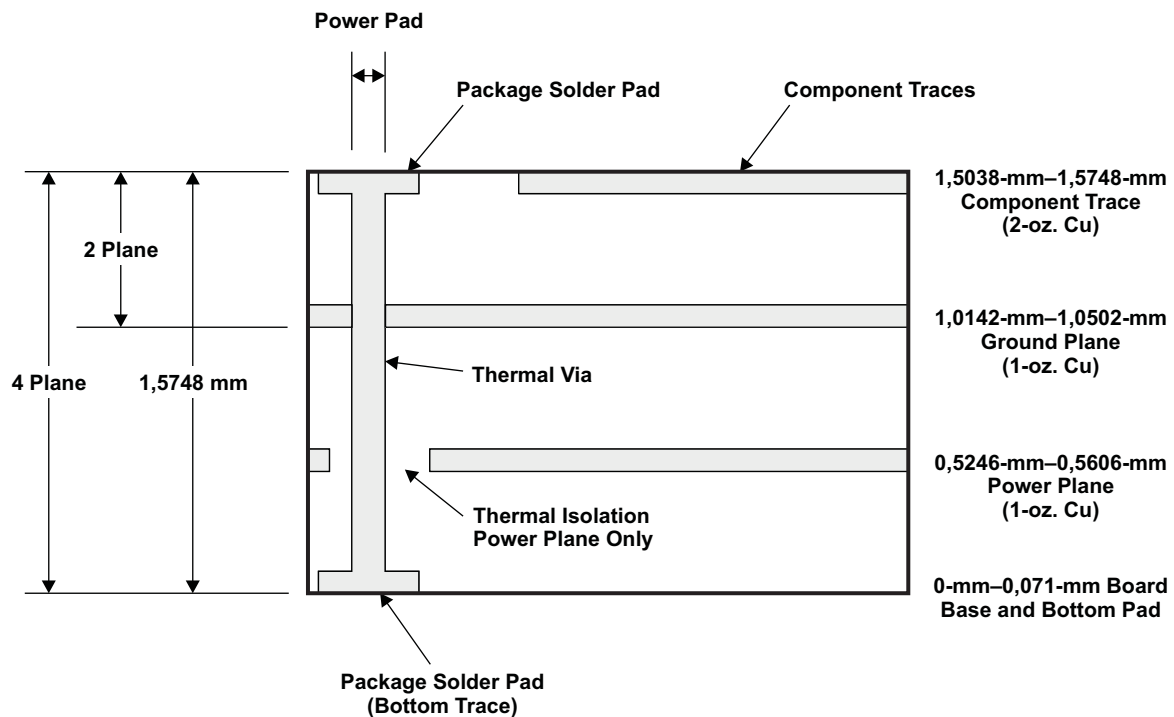

M0027-01

Figure 23. Multilayer Board (Side View)

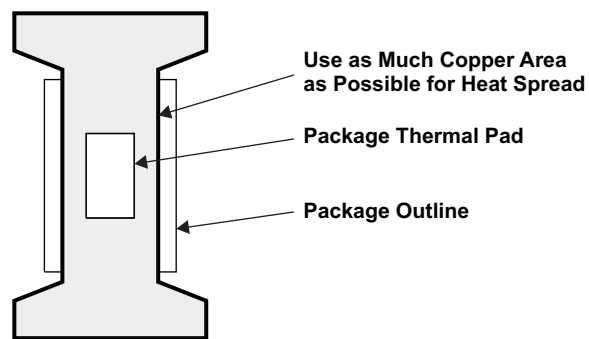
Layout Guidelines (continued)
10.1.4 Single-Layer

M0028-01

Figure 24. Land Configuration for Single-Layer PCB

When this attachment method is not implemented correctly, this product may operate inefficiently. Power dissipation capability may be adversely affected when the device is incorrectly mounted onto the circuit board.

10.2 Layout Example

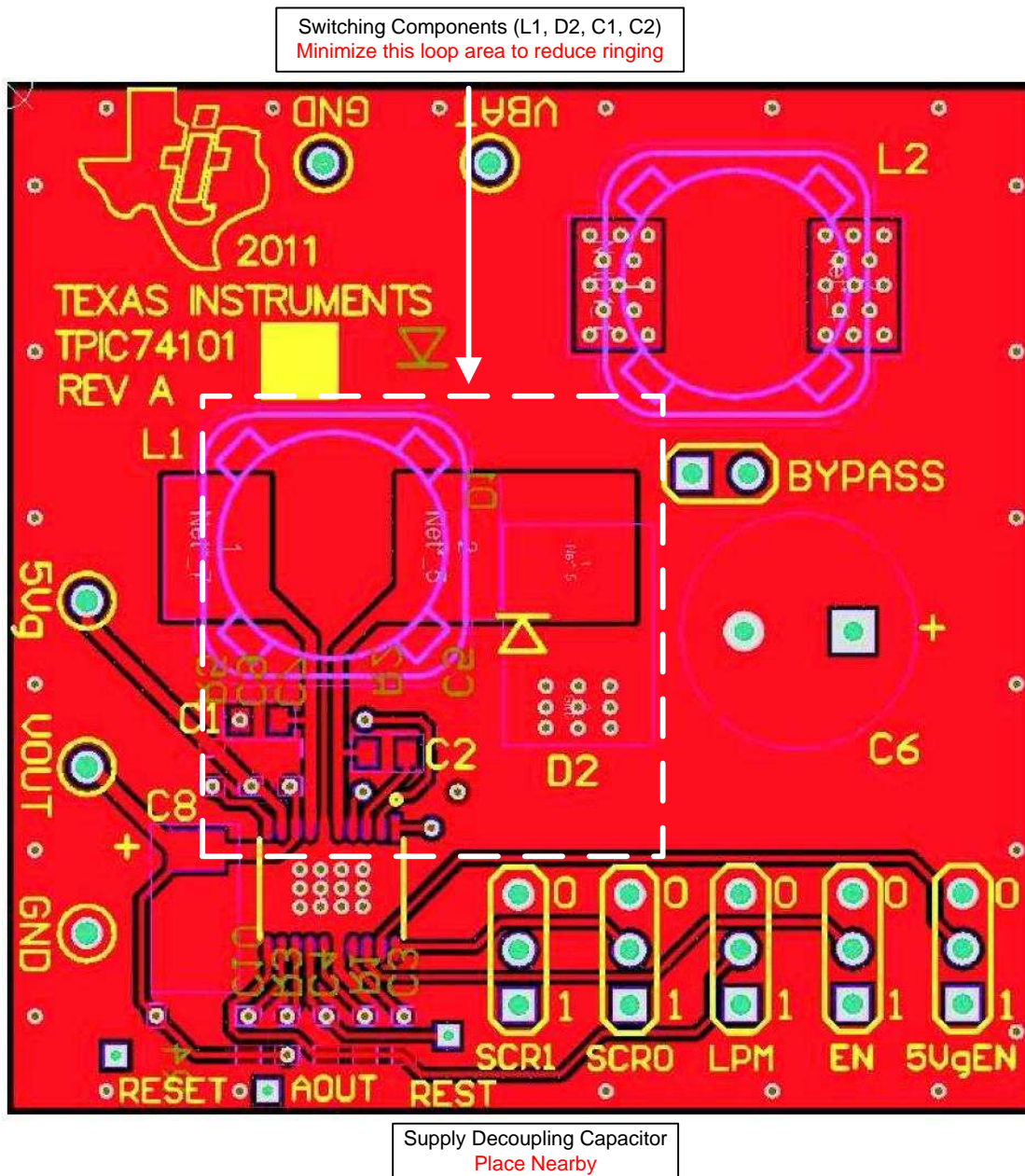

Figure 25. Layout Example 1

Layout Example (continued)

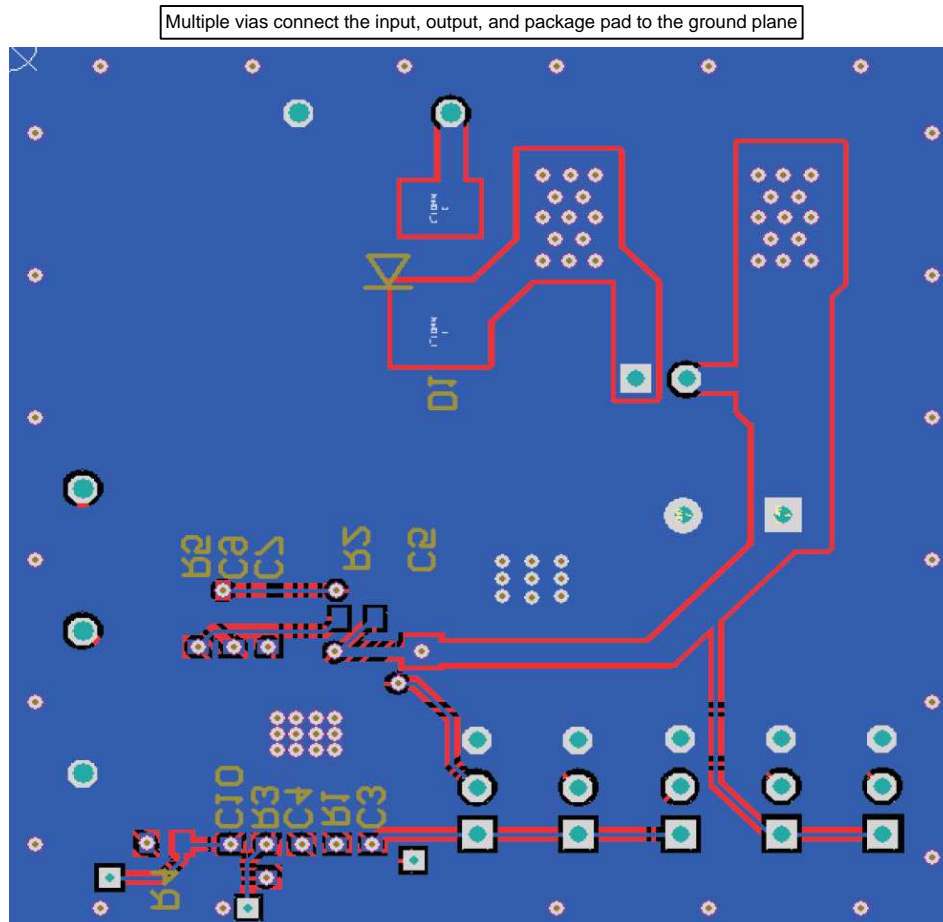

Figure 26. Layout Example 2

11 Device and Documentation Support

11.1 Trademarks

PowerPAD is a trademark of Texas Instruments.
All other trademarks are the property of their respective owners.

11.2 Electrostatic Discharge Caution



These devices have limited built-in ESD protection. The leads should be shorted together or the device placed in conductive foam during storage or handling to prevent electrostatic damage to the MOS gates.

11.3 Glossary

[SLYZ022](#) — *TI Glossary*.

This glossary lists and explains terms, acronyms, and definitions.

12 Mechanical, Packaging, and Orderable Information

The following pages include mechanical, packaging, and orderable information. This information is the most current data available for the designated devices. This data is subject to change without notice and revision of this document. For browser-based versions of this data sheet, refer to the left-hand navigation.

PACKAGING INFORMATION

Orderable Device	Status (1)	Package Type	Package Drawing	Pins	Package Qty	Eco Plan (2)	Lead/Ball Finish (6)	MSL Peak Temp (3)	Op Temp (°C)	Device Marking (4/5)	Samples
TPIC74101QPWRQ1	ACTIVE	HTSSOP	PWP	20	2000	Green (RoHS & no Sb/Br)	CU NIPDAU	Level-3-260C-168 HR	-40 to 125	T74101D5	Samples

(1) The marketing status values are defined as follows:

ACTIVE: Product device recommended for new designs.

LIFEBUY: TI has announced that the device will be discontinued, and a lifetime-buy period is in effect.

NRND: Not recommended for new designs. Device is in production to support existing customers, but TI does not recommend using this part in a new design.

PREVIEW: Device has been announced but is not in production. Samples may or may not be available.

OBSELETE: TI has discontinued the production of the device.

(2) Eco Plan - The planned eco-friendly classification: Pb-Free (RoHS), Pb-Free (RoHS Exempt), or Green (RoHS & no Sb/Br) - please check <http://www.ti.com/productcontent> for the latest availability information and additional product content details.

TBD: The Pb-Free/Green conversion plan has not been defined.

Pb-Free (RoHS): TI's terms "Lead-Free" or "Pb-Free" mean semiconductor products that are compatible with the current RoHS requirements for all 6 substances, including the requirement that lead not exceed 0.1% by weight in homogeneous materials. Where designed to be soldered at high temperatures, TI Pb-Free products are suitable for use in specified lead-free processes.

Pb-Free (RoHS Exempt): This component has a RoHS exemption for either 1) lead-based flip-chip solder bumps used between the die and package, or 2) lead-based die adhesive used between the die and leadframe. The component is otherwise considered Pb-Free (RoHS compatible) as defined above.

Green (RoHS & no Sb/Br): TI defines "Green" to mean Pb-Free (RoHS compatible), and free of Bromine (Br) and Antimony (Sb) based flame retardants (Br or Sb do not exceed 0.1% by weight in homogeneous material)

(3) MSL, Peak Temp. - The Moisture Sensitivity Level rating according to the JEDEC industry standard classifications, and peak solder temperature.

(4) There may be additional marking, which relates to the logo, the lot trace code information, or the environmental category on the device.

(5) Multiple Device Markings will be inside parentheses. Only one Device Marking contained in parentheses and separated by a "~" will appear on a device. If a line is indented then it is a continuation of the previous line and the two combined represent the entire Device Marking for that device.

(6) Lead/Ball Finish - Orderable Devices may have multiple material finish options. Finish options are separated by a vertical ruled line. Lead/Ball Finish values may wrap to two lines if the finish value exceeds the maximum column width.

Important Information and Disclaimer: The information provided on this page represents TI's knowledge and belief as of the date that it is provided. TI bases its knowledge and belief on information provided by third parties, and makes no representation or warranty as to the accuracy of such information. Efforts are underway to better integrate information from third parties. TI has taken and continues to take reasonable steps to provide representative and accurate information but may not have conducted destructive testing or chemical analysis on incoming materials and chemicals. TI and TI suppliers consider certain information to be proprietary, and thus CAS numbers and other limited information may not be available for release.

In no event shall TI's liability arising out of such information exceed the total purchase price of the TI part(s) at issue in this document sold by TI to Customer on an annual basis.

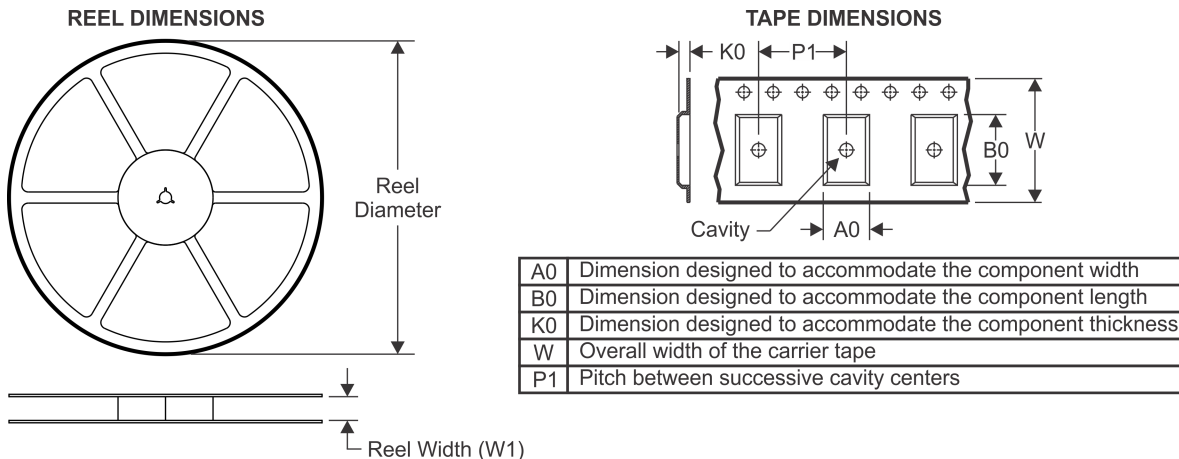
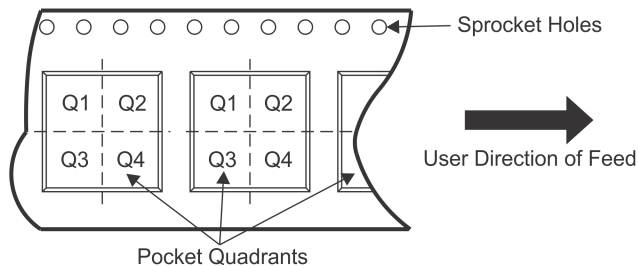
TAPE AND REEL INFORMATION

QUADRANT ASSIGNMENTS FOR PIN 1 ORIENTATION IN TAPE

*All dimensions are nominal

Device	Package Type	Package Drawing	Pins	SPQ	Reel Diameter (mm)	Reel Width W1 (mm)	A0 (mm)	B0 (mm)	K0 (mm)	P1 (mm)	W (mm)	Pin1 Quadrant
TPIC74101QPWPRQ1	HTSSOP	PWP	20	2000	330.0	16.4	6.95	7.1	1.6	8.0	16.0	Q1

TAPE AND REEL BOX DIMENSIONS



*All dimensions are nominal

Device	Package Type	Package Drawing	Pins	SPQ	Length (mm)	Width (mm)	Height (mm)
TPIC74101QPWPRQ1	HTSSOP	PWP	20	2000	350.0	350.0	43.0

MECHANICAL DATA

PWP (R-PDSO-G20)

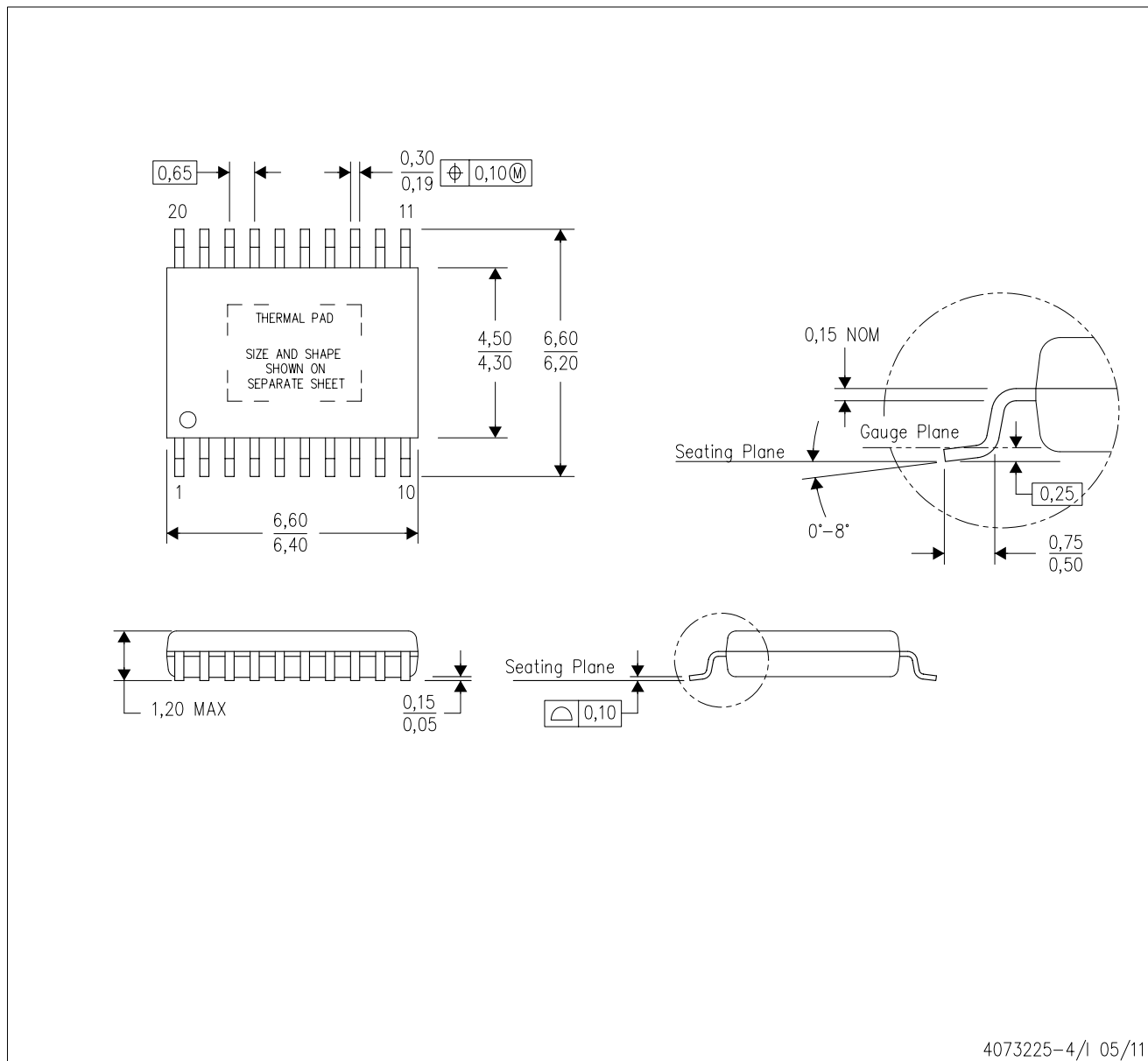
PowerPAD™ PLASTIC SMALL OUTLINE



4073225-4/1 05/11

- NOTES:
- All linear dimensions are in millimeters.
 - This drawing is subject to change without notice.
 - Body dimensions do not include mold flash or protrusions. Mold flash and protrusion shall not exceed 0.15 per side.
 - This package is designed to be soldered to a thermal pad on the board. Refer to Technical Brief, PowerPad Thermally Enhanced Package, Texas Instruments Literature No. SLMA002 for information regarding recommended board layout. This document is available at www.ti.com <<http://www.ti.com>>.
 - See the additional figure in the Product Data Sheet for details regarding the exposed thermal pad features and dimensions.
 - Falls within JEDEC MO-153

PowerPAD is a trademark of Texas Instruments.

THERMAL PAD MECHANICAL DATA

PWP (R-PDSO-G20) PowerPAD™ SMALL PLASTIC OUTLINE

THERMAL INFORMATION

This PowerPAD™ package incorporates an exposed thermal pad that is designed to be attached to a printed circuit board (PCB). The thermal pad must be soldered directly to the PCB. After soldering, the PCB can be used as a heatsink. In addition, through the use of thermal vias, the thermal pad can be attached directly to the appropriate copper plane shown in the electrical schematic for the device, or alternatively, can be attached to a special heatsink structure designed into the PCB. This design optimizes the heat transfer from the integrated circuit (IC).

For additional information on the PowerPAD package and how to take advantage of its heat dissipating abilities, refer to Technical Brief, PowerPAD Thermally Enhanced Package, Texas Instruments Literature No. SLMA002 and Application Brief, PowerPAD Made Easy, Texas Instruments Literature No. SLMA004. Both documents are available at www.ti.com.

The exposed thermal pad dimensions for this package are shown in the following illustration.

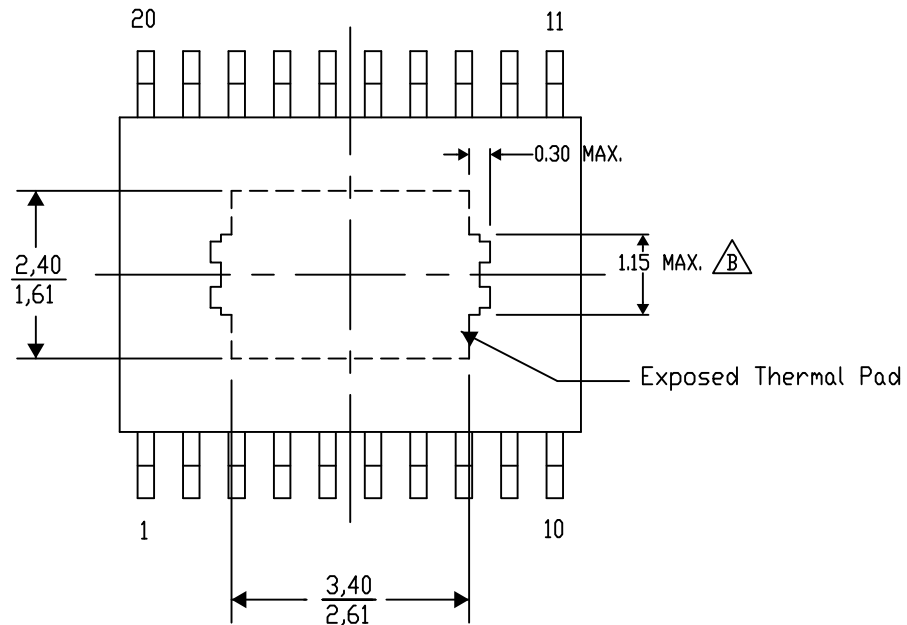

4206332-15/AO 01/16

NOTE: A. All linear dimensions are in millimeters

 Exposed tie strap features may not be present.

PowerPAD is a trademark of Texas Instruments

PWP (R-PDSO-G20)

PowerPAD™ PLASTIC SMALL OUTLINE

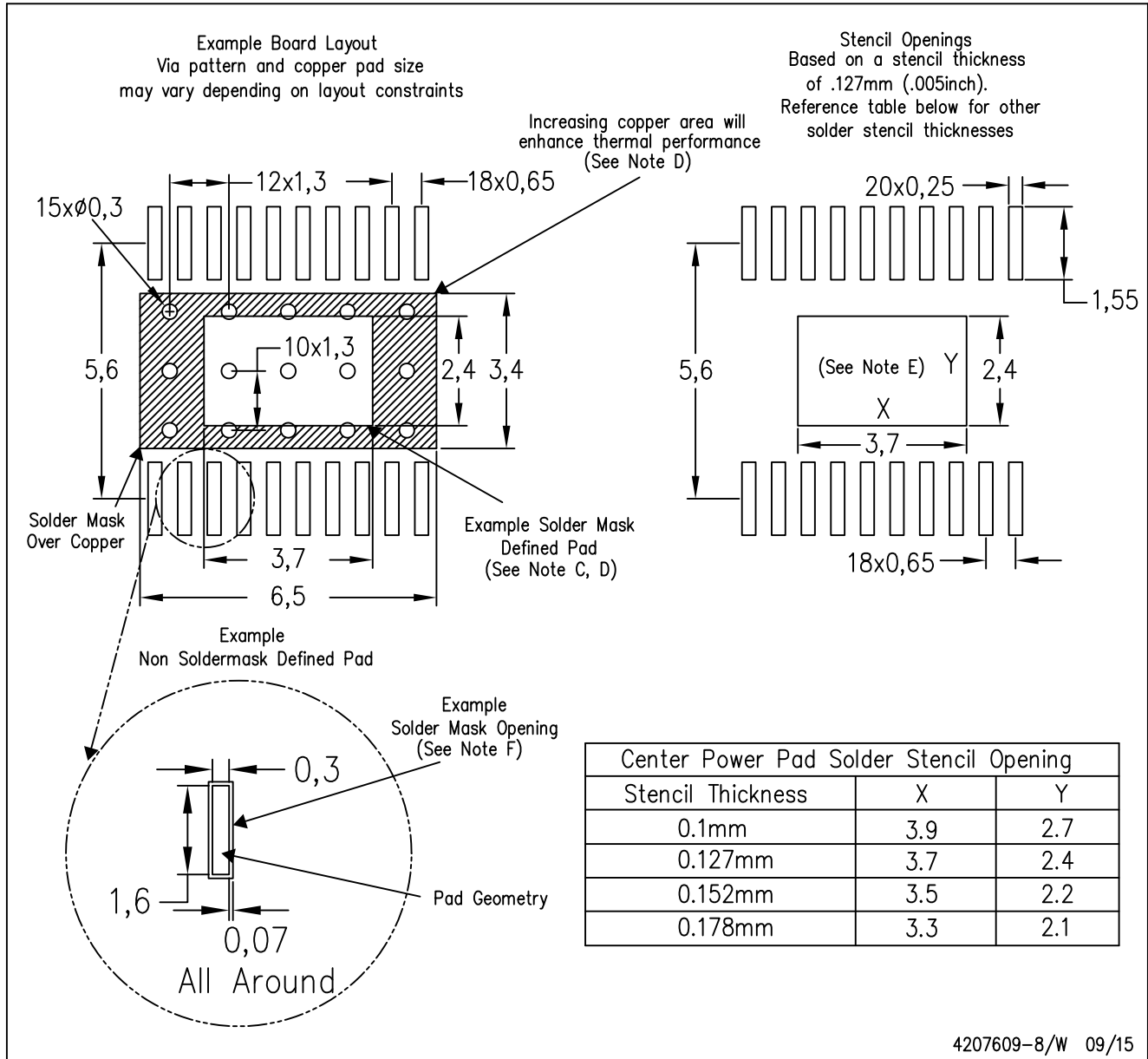

- NOTES:
- A. All linear dimensions are in millimeters.
 - B. This drawing is subject to change without notice.
 - C. Customers should place a note on the circuit board fabrication drawing not to alter the center solder mask defined pad.
 - D. This package is designed to be soldered to a thermal pad on the board. Refer to Technical Brief, PowerPad Thermally Enhanced Package, Texas Instruments Literature No. SLMA002, SLMA004, and also the Product Data Sheets for specific thermal information, via requirements, and recommended board layout. These documents are available at www.ti.com <<http://www.ti.com>>. Publication IPC-7351 is recommended for alternate designs.
 - E. Laser cutting apertures with trapezoidal walls and also rounding corners will offer better paste release. Customers should contact their board assembly site for stencil design recommendations. Example stencil design based on a 50% volumetric metal load solder paste. Refer to IPC-7525 for other stencil recommendations.
 - F. Customers should contact their board fabrication site for solder mask tolerances between and around signal pads.

IMPORTANT NOTICE AND DISCLAIMER

TI PROVIDES TECHNICAL AND RELIABILITY DATA (INCLUDING DATASHEETS), DESIGN RESOURCES (INCLUDING REFERENCE DESIGNS), APPLICATION OR OTHER DESIGN ADVICE, WEB TOOLS, SAFETY INFORMATION, AND OTHER RESOURCES "AS IS" AND WITH ALL FAULTS, AND DISCLAIMS ALL WARRANTIES, EXPRESS AND IMPLIED, INCLUDING WITHOUT LIMITATION ANY IMPLIED WARRANTIES OF MERCHANTABILITY, FITNESS FOR A PARTICULAR PURPOSE OR NON-INFRINGEMENT OF THIRD PARTY INTELLECTUAL PROPERTY RIGHTS.

These resources are intended for skilled developers designing with TI products. You are solely responsible for (1) selecting the appropriate TI products for your application, (2) designing, validating and testing your application, and (3) ensuring your application meets applicable standards, and any other safety, security, or other requirements. These resources are subject to change without notice. TI grants you permission to use these resources only for development of an application that uses the TI products described in the resource. Other reproduction and display of these resources is prohibited. No license is granted to any other TI intellectual property right or to any third party intellectual property right. TI disclaims responsibility for, and you will fully indemnify TI and its representatives against, any claims, damages, costs, losses, and liabilities arising out of your use of these resources.

TI's products are provided subject to TI's Terms of Sale (www.ti.com/legal/termsofsale.html) or other applicable terms available either on ti.com or provided in conjunction with such TI products. TI's provision of these resources does not expand or otherwise alter TI's applicable warranties or warranty disclaimers for TI products.

Mailing Address: Texas Instruments, Post Office Box 655303, Dallas, Texas 75265
Copyright © 2019, Texas Instruments Incorporated

Looking for pricing, stock, or lifecycle information?

Click below to explore more details on WIN SOURCE:

 [View TPIC74101QPWPRQ1 on WIN SOURCE](#)

 [Texas Instruments](#) Information

Optimize Your Supply Chain with WIN SOURCE Solutions

-  Global Sourcing Solution
-  Obsolete Management
-  Cost Control Management
-  Shortage Management
-  Alternative Solution
-  Excess Inventory Management