



**THE DATASHEET OF  
STB16PF06LT4**





# STB16PF06L

P-CHANNEL 60V - 0.11Ω - 16A D2PAK

STripFET™ MOSFET

Table 1: General Features

TYPE	V <sub>DSS</sub>	R <sub>DS(on)</sub>	I <sub>D</sub>	P <sub>w</sub>
STB16PF06L	60 V	< 0.125 Ω	16 A	70 W

- TYPICAL R<sub>DS(on)</sub> = 0.11 Ω
- LOW THRESHOLD DEVICE
- LOW GATE CHARGE

### DESCRIPTION

This MOSFET is the latest development of STMicroelectronics unique "Single Feature Size™" strip-based process. The resulting transistor shows extremely high packing density for low on-resistance, rugged avalanche characteristics and less critical alignment steps therefore a remarkable manufacturing reproducibility.

### APPLICATIONS

- MOTOR CONTROL
- DC-DC CONVERTERS

Figure 1: Package

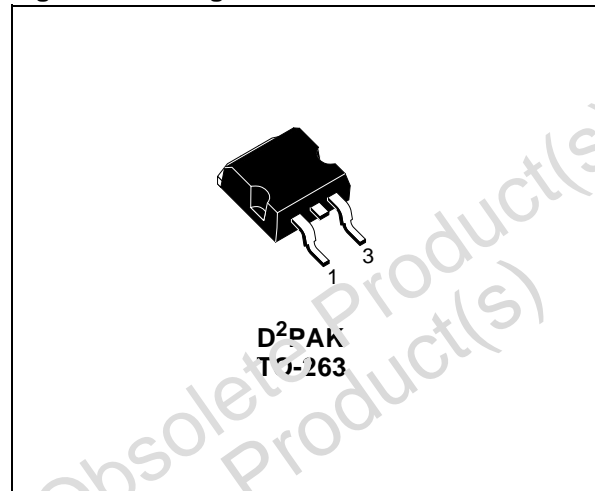

Figure 2: Internal Schematic Diagram

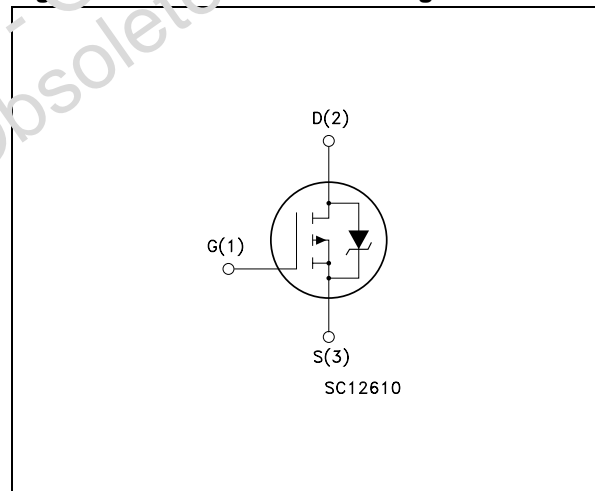

Table 2: Order Codes

PART NUMBER	MARKING	PACKAGE	PACKAGING
STB16PF06LT4	B16PF06L	D <sup>2</sup> PAK	TAPE & REEL

**Table 3: Absolute Maximum ratings**

Symbol	Parameter	Value	Unit
$V_{DS}$	Drain-source Voltage ( $V_{GS} = 0$ )	60	V
$V_{DGR}$	Drain-gate Voltage ( $R_{GS} = 20\text{ k}\Omega$ )	60	V
$V_{GS}$	Gate-source Voltage	$\pm 16$	V
$I_D$	Drain Current (continuous) at $T_C = 25^\circ\text{C}$	16	A
$I_D$	Drain Current (continuous) at $T_C = 100^\circ\text{C}$	11.4	A
$I_{DM}(\bullet)$	Drain Current (pulsed)	64	A
$P_{TOT}$	Total Dissipation at $T_C = 25^\circ\text{C}$	70	W
	Derating Factor	0.4	W/ $^\circ\text{C}$
dv/dt (1)	Peak Diode Recovery voltage slope	20	V/ns
$E_{AS}$ (2)	Single Pulse Avalanche Energy	250	mJ
$T_j$ $T_{stg}$	Operating Junction Temperature Storage Temperature	- 55 to 175	$^\circ\text{C}$

( $\bullet$ ) Pulse width limited by safe operating area

(1)  $I_{SD} \leq 16\text{A}$ ,  $di/dt \leq 100\text{A}/\mu\text{s}$ ,  $V_{DD} \leq V_{(BR)DSS}$ ,  $T_j \leq T_{JMAX}$ .

(2) Starting  $T_j = 25^\circ\text{C}$ ,  $I_D = 8\text{ A}$ ,  $V_{DD} = 30\text{ V}$

Note: For the P-CHANNEL MOSFET actual polarity of voltages and current has to be reverse

**Table 4: Thermal Data**

Rthj-case	Thermal Resistance Junction-case Max	2,14	$^\circ\text{C}/\text{W}$
Rthj-PCB(#)	Thermal Resistance Junction-PCB Max	34	$^\circ\text{C}/\text{W}$
$T_l$	Maximum Lead Temperature For Soldering Purpose (1.6 mm from case, for 10sec)	300	$^\circ\text{C}$

(#) When Mounted on 1 inch<sup>2</sup> FR-4 board, 2 oz of Cu

**ELECTRICAL CHARACTERISTICS ( $T_{CASE} = 25^\circ\text{C}$  UNLESS OTHERWISE SPECIFIED)**

**Table 5: On/Off**

Symbol	Parameter	Test Conditions	Min.	Typ.	Max.	Unit
$V_{(BR)DSS}$	Drain-source Breakdown Voltage	$I_D = 250\mu\text{A}$ , $V_{GS} = 0$	60			V
$I_{DSS}$	Zero Gate Voltage Drain Current ( $V_{GS} = 0$ )	$V_{DS} = \text{Max Rating}$ $V_{DS} = \text{Max Rating}$ , $T_C = 125^\circ\text{C}$			1 10	$\mu\text{A}$ $\mu\text{A}$
$I_{GSS}$	Gate-body Leakage Current ( $V_{DS} = 0$ )	$V_{GS} = \pm 16\text{V}$			$\pm 100$	nA
$V_{GS(th)}$	Gate Threshold Voltage	$V_{DS} = V_{GS}$ , $I_D = 100\mu\text{A}$	1.5			V
$R_{DS(on)}$	Static Drain-source On Resistance	$V_{GS} = 10\text{V}$ , $I_D = 8\text{ A}$ $V_{GS} = 5\text{V}$ , $I_D = 8\text{ A}$		0.11 0.130	0.125 0.165	$\Omega$ $\Omega$

## ELECTRICAL CHARACTERISTICS (CONTINUED)

Table 6: Dynamic

Symbol	Parameter	Test Conditions	Min.	Typ.	Max.	Unit
$g_{fs}$	Forward Transconductance	$V_{DS} = 10\text{ V}$ , $I_D = 3\text{ A}$		7.2		S
$C_{iss}$ $C_{oss}$ $C_{rss}$	Input Capacitance Output Capacitance Reverse Transfer Capacitance	$V_{DS} = 25\text{ V}$ , $f = 1\text{ MHz}$ , $V_{GS} = 0$		630 121 49		pF pF pF
$t_{d(on)}$ $t_r$ $t_{d(off)}$ $t_f$	Turn-on Delay Time Rise Time Turn-off Delay Time Fall Time	$V_{DD} = 30\text{ V}$ , $I_D = 8\text{ A}$ , $R_G = 4.7\Omega$ $V_{GS} = 4.5\text{ V}$ (Resistive Load, Figure 1)		129 90 25.5 19.5		ns ns ns ns
$Q_g$ $Q_{gs}$ $Q_{gd}$	Total Gate Charge Gate-Source Charge Gate-Drain Charge	$V_{DD} = 48\text{ V}$ , $I_D = 16\text{ A}$ , $V_{GS} = 4.5\text{ V}$ (See test circuit, Figure 2)		11.4 5.2 4.7	15.5	nC nC nC

Table 7: Source Drain Diode

Symbol	Parameter	Test Conditions	Min.	Typ.	Max.	Unit
$I_{SD}$ $I_{SDM(2)}$	Source-drain Current Source-drain Current (pulsed)				16 64	A A
$V_{SD(1)}$	Forward On Voltage	$I_{SD} = 8\text{ A}$ , $V_{GS} = 0$			1.3	V
$t_{rr}$ $Q_{rr}$ $I_{RRM}$	Reverse Recovery Time Reverse Recovery Charge Reverse Recovery Current	$I_{SD} = 16\text{ A}$ , $di/dt = 100\text{ A}/\mu\text{s}$ $V_{DD} = 20\text{ V}$ , $T_j = 150^\circ\text{C}$ (see test circuit, Figure 3)		48.5 87.3 3.6		ns nC A

Note: 1. Pulsed: Pulse duration = 300  $\mu\text{s}$ , duty cycle 1.5 %.  
2. Pulse width limited by safe operating area.

Figure 3: Safe Operating Area

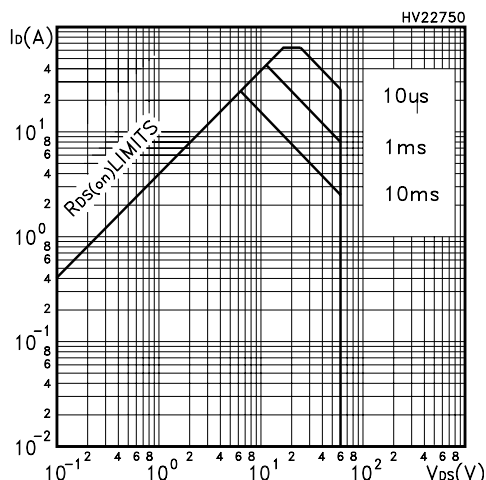

Figure 4: Output Characteristics

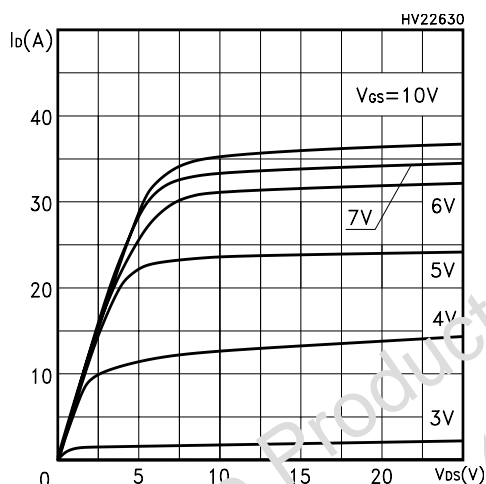

Figure 5: Transconductance

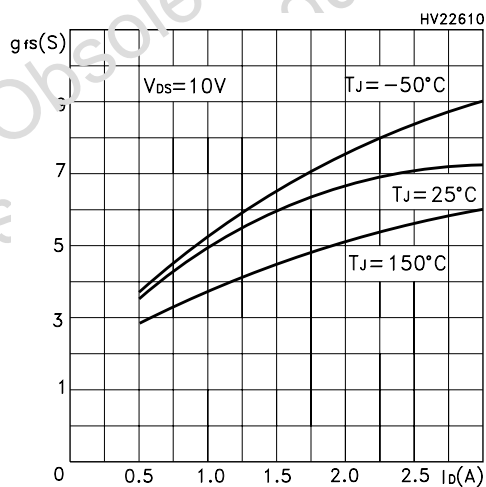

Figure 6: Thermal Impedance

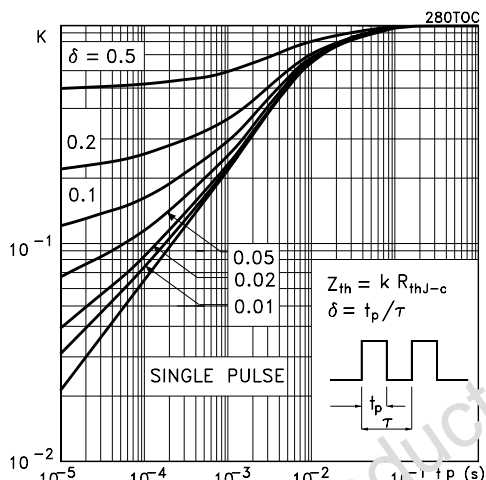

Figure 7: Transfer Characteristics

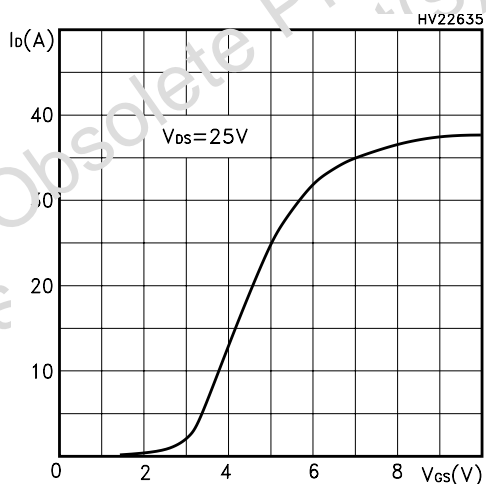

Figure 8: Static Drain-source On Resistance

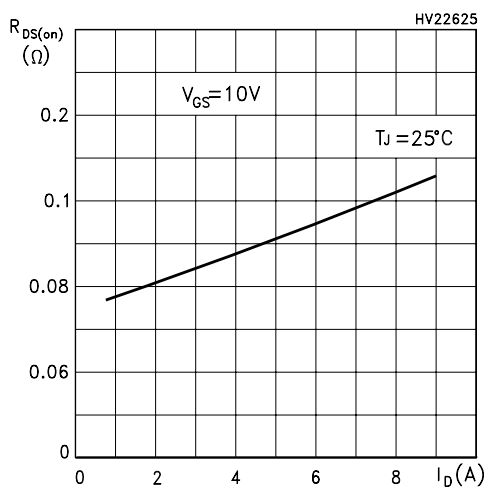

Figure 9: Gate Charge vs Gate-source Voltage

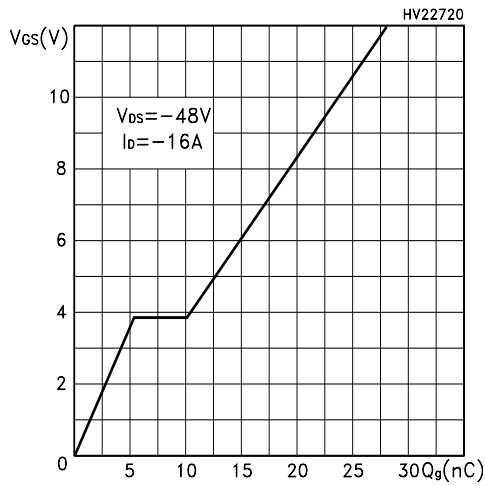

Figure 10: Normalized Gate Threshold Voltage vs Temperature

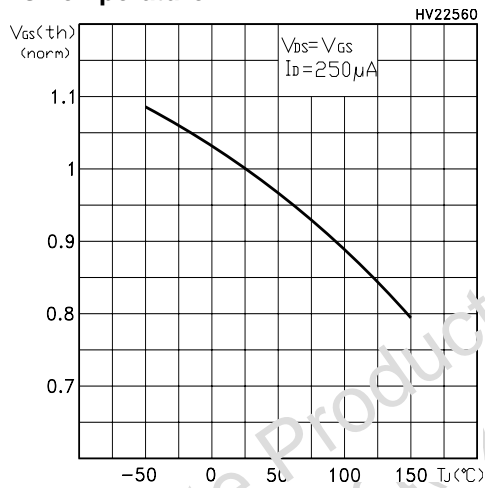

Figure 11: Dource-Drain Diode Forward Characteristics

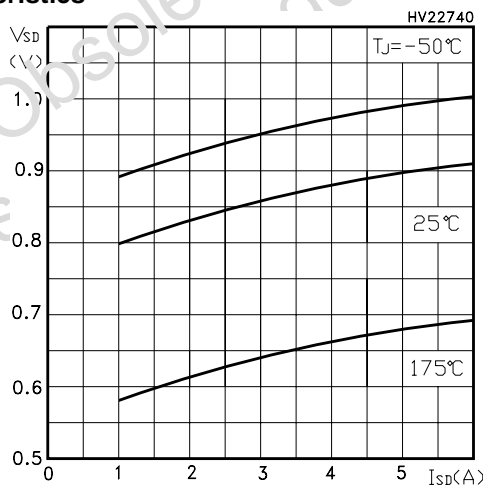

Figure 12: Capacitance Variations

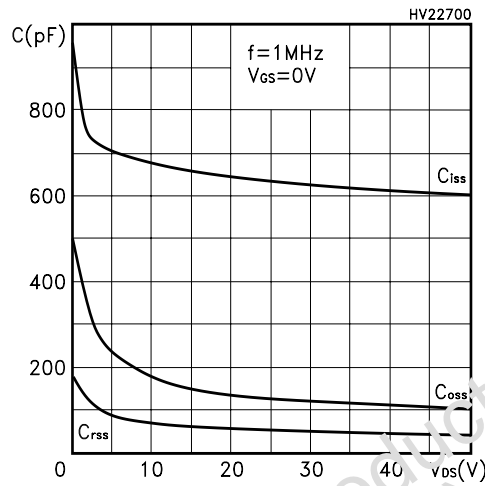

Figure 13: Normalized On Resistance vs Temperature

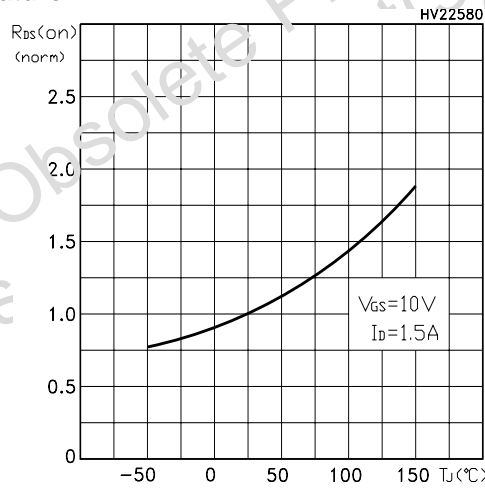

Figure 14: Normalized Breakdown Voltage vs Temperature

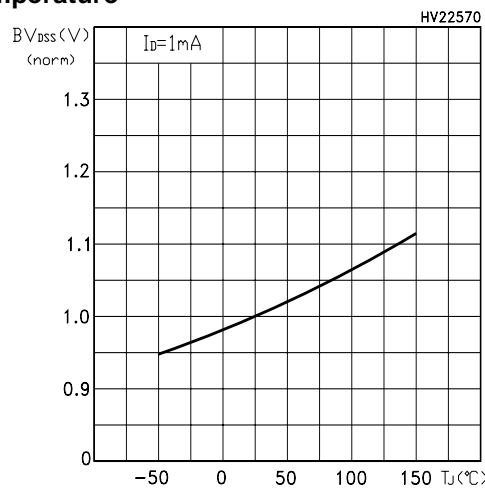

Figure 15: Unclamped Inductive Load Test Circuit

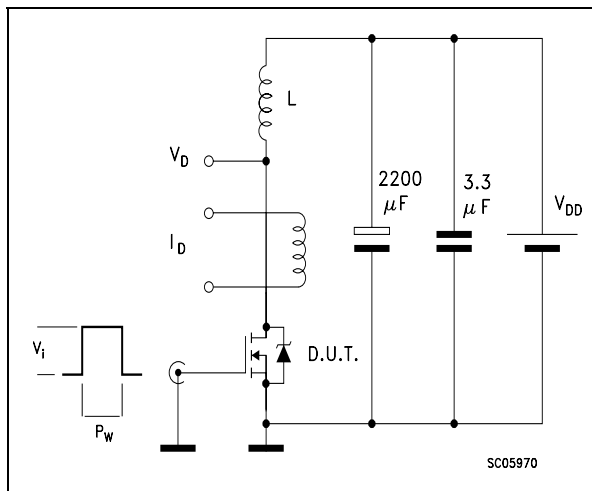

Figure 16: Switching Times Test Circuit For Resistive Load

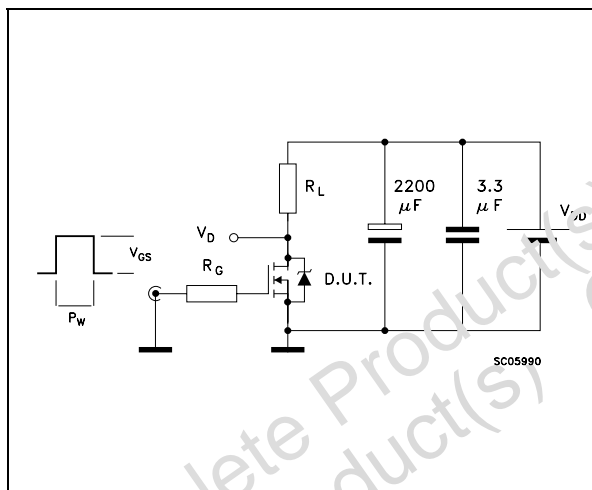

Figure 17: Test Circuit For Inductive Load Switching and Diode Recovery Times

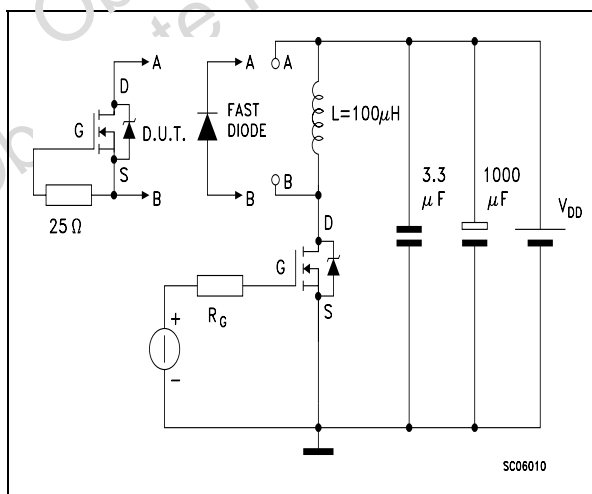

Figure 18: Unclamped Inductive Waferform

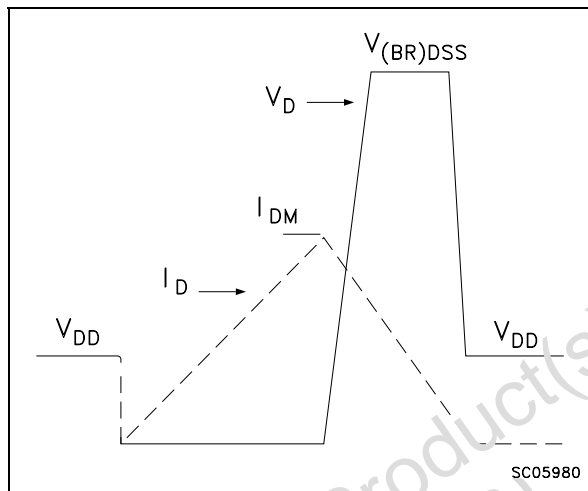
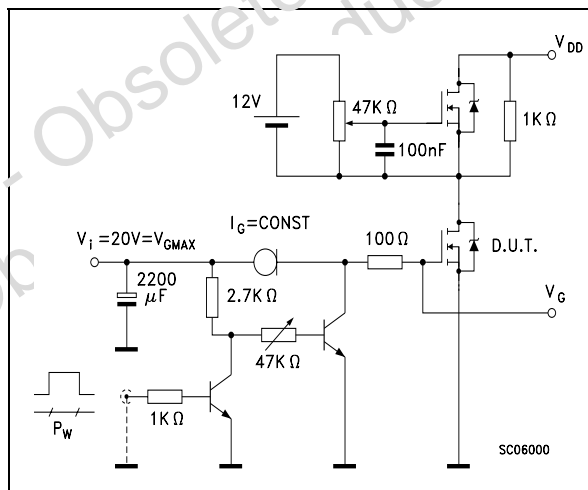
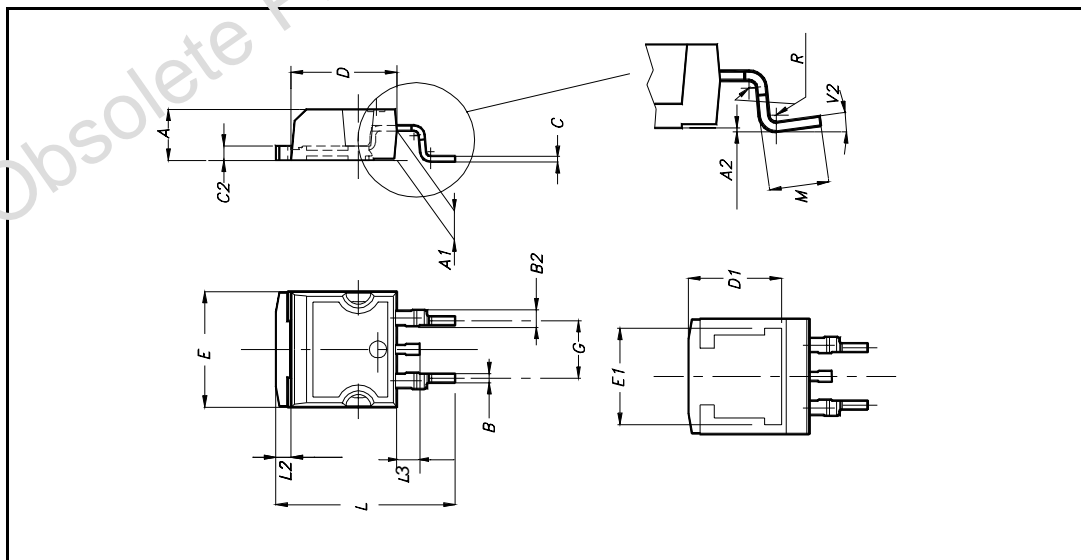

Figure 19: Gate Charge Test Circuit



**D<sup>2</sup>PAK MECHANICAL DATA**

DIM.	mm.			inch		
	MIN.	TYP	MAX.	MIN.	TYP.	MAX.
A	4.4		4.6	0.173		0.181
A1	2.49		2.69	0.098		0.106
A2	0.03		0.23	0.001		0.009
B	0.7		0.93	0.027		0.036
B2	1.14		1.7	0.044		0.067
C	0.45		0.6	0.017		0.023
C2	1.23		1.36	0.048		0.053
D	8.95		9.35	0.352		0.368
D1		8			0.315	
E	10		10.4	0.393		
E1		8.5			0.334	
G	4.88		5.28	0.192		0.208
L	15		15.85	0.590		0.625
L2	1.27		1.4	0.050		0.055
L3	1.4		1.75	0.055		0.068
M	2.4		3.2	0.094		0.126
R		0.4			0.015	
V2	0°		4°			



**D<sup>2</sup>PAK FOOTPRINT**

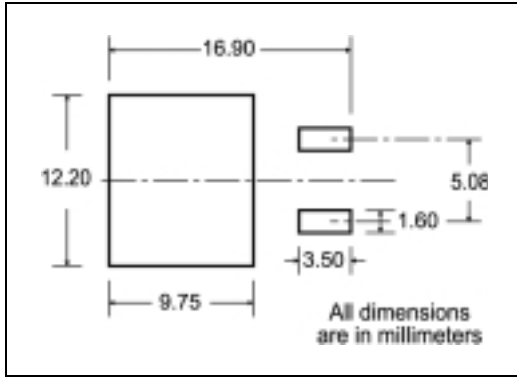

**TUBE SHIPMENT (no suffix)\***

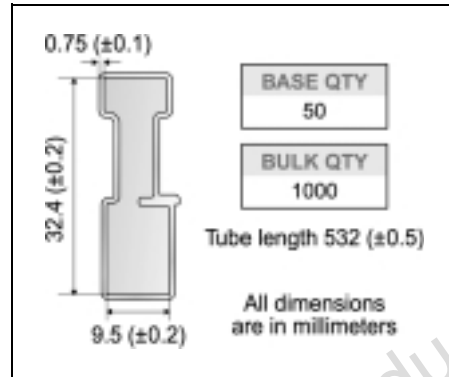

**TAPE AND REEL SHIPMENT (suffix "T4")\***

**TAPE MECHANICAL DATA**

DIM.	mm		inch	
	MIN.	MAX.	MIN.	MAX.
A0	10.5	10.7	0.413	0.421
P0	15.7	15.9	0.618	0.626
D	1.5	1.6	0.059	0.063
D1	1.59	1.61	0.062	0.063
E	1.65	1.85	0.065	0.073
F	11.4	11.6	0.449	0.456
K0	4.8	5.0	0.189	0.197
P0	3.9	4.1	0.153	0.161
P1	11.9	12.1	0.468	0.476
P2	1.9	2.1	0.075	0.082
R	50		1.574	
T	0.25	0.35	0.0098	0.0137
W	23.7	24.3	0.933	0.956

**REEL MECHANICAL DATA**

DIM.	mm		inch	
	MIN.	MAX.	MIN.	MAX.
A		330		12.992
B	1.5		0.059	
C	12.8	13.2	0.504	0.520
D	20.2		0.795	
G	24.4	26.4	0.960	1.039
N	100		3.937	
T		30.4		1.197

BASE QTY	BULK QTY
1000	1000

\* on sales type

**Table 8: Revision History**

Date	Revision	Description of Changes
13/Sep/2004	1	First Release.

Obsolete Product(s) - Obsolete Product(s)  
Obsolete Product(s) - Obsolete Product(s)

Information furnished is believed to be accurate and reliable. However, STMicroelectronics assumes no responsibility for the consequences of use of such information nor for any infringement of patents or other rights of third parties which may result from its use. No license is granted by implication or otherwise under any patent or patent rights of STMicroelectronics. Specifications mentioned in this publication are subject to change without notice. This publication supersedes and replaces all information previously supplied. STMicroelectronics products are not authorized for use as critical components in life support devices or systems without express written approval of STMicroelectronics.

The ST logo is a registered trademark of STMicroelectronics

All other names are the property of their respective owners



© 2004 STMicroelectronics - All Rights Reserved

STMicroelectronics group of companies

Australia - Belgium - Brazil - Canada - China - Czech Republic - Finland - France - Germany - Hong Kong - India - Israel - Italy - Japan - Malaysia - Malta - Morocco - Singapore - Spain - Sweden - Switzerland - United Kingdom - United States of America

## Looking for pricing, stock, or lifecycle information?

Click below to explore more details on WIN SOURCE:

-  [View STB16PF06LT4](#) on WIN SOURCE
-  [STMicroelectronics](#) Information

## Optimize Your Supply Chain with WIN SOURCE Solutions

-  Global Sourcing Solution
-  Obsolete Management
-  Cost Control Management
-  Shortage Management
-  Alternative Solution
-  Excess Inventory Management