



**THE DATASHEET OF
FDDS10H04A_F085A**



FDDS10H04A_F085A Smart High Side Switch

Features

- Short circuit protection with latch
- Current limitation
- Overload protection
- Thermal shutdown with restart.
- Overvoltage protection(including load dump)
- Loss of ground protection
- Loss of supply protection(with external diode for charged inductive load)
- Very low standby current
- Fast demagnetization of inductive loads
- ESD protection
- Optimized static electromagnetic compatibility
- Diagnostic function - Proportional load current sense(with defined fault signal in case of overload operation, overtemperature shutdown and/or short circuit shutdown)
- Qualified to AEC

Typical Applications

- Power switch with current sense diagnostic feedback for DC ground loads
- All types of resistive, inductive, and capacitive loads
- Replace electromechanical relays, fuses and discrete circuits

Description

N channel power FET with charge pump, current controlled input and diagnostic feedback with load current sense, integrated in smart Trench chip on chip technology. Provides embedded protective functions.

TO252-5L

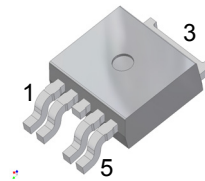

Ordering Information

Part Number	Package	Operating Temperature	 Eco Status	Packing Method
FDDS10H04A_F085A	TO252-5L	-40 °C - 150 °C	RoHS	Tape & Reel



For Fairchild's definition of "green" Eco Status, please visit: http://www.fairchildsemi.com/company/green/rohs_green.html.

Block Diagrams

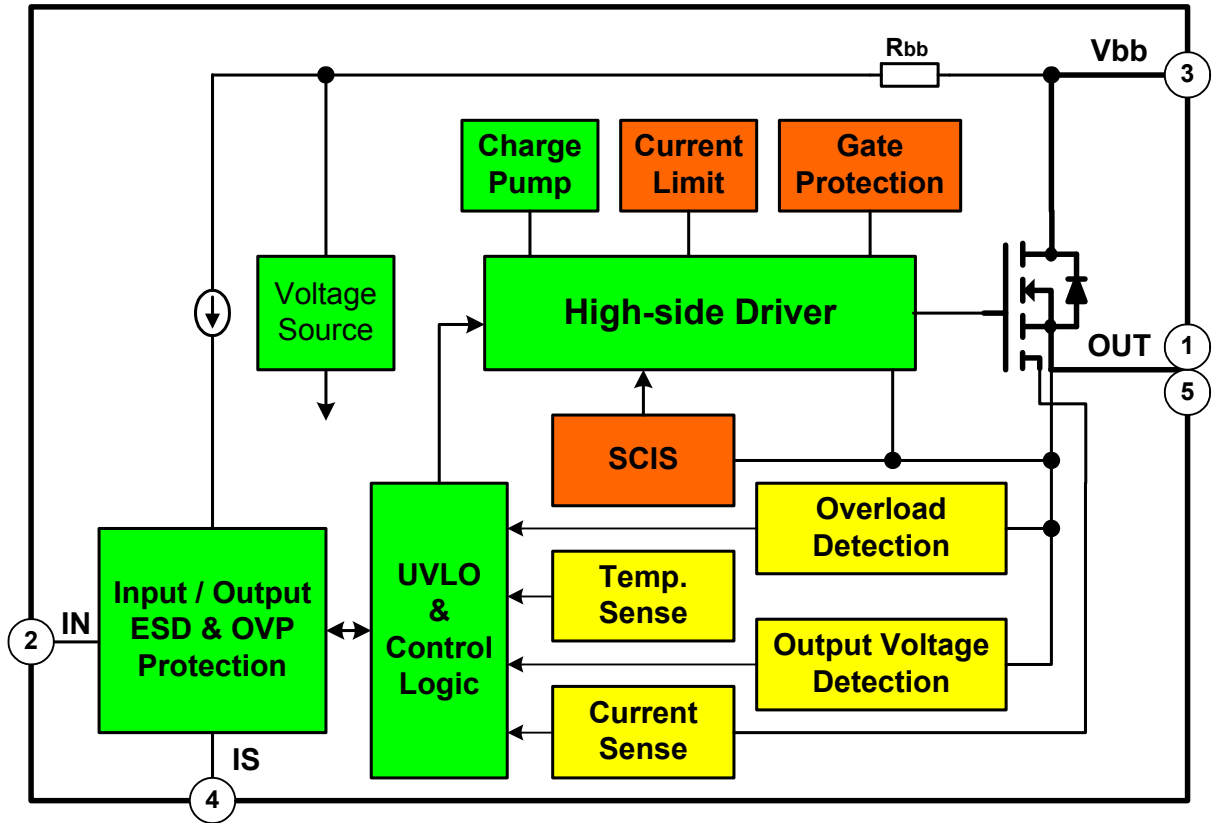

Pin Definitions

Pin Number	Pin Name	I/O	Pin Function Description
1	OUT	A	Output to loads; Pin1 and 5 must be externally shorted
2	IN	A	Input: activates the power switch if shorted to ground
3	Vbb	P	Supply voltage; Pin3 and TAB are internally shorted
4	IS	A	Sense output ; Diagnostic feedback; Provides at normal operation a sense current proportion to the load current; in case of overload, over temperature and/or short circuit a defined current is provided
5	OUT	A	Output to loads; Pin1 and 5 must be externally shorted

Absolute Maximum Ratings

At Tj=25°C unless otherwise specified.

Parameter	Symbol	Values	Unit	
Supply voltage ⁴⁾	V _{bb}	38	V	
Supply voltage for full short circuit protection ¹⁾	V _{bb}	30	V	
Load dump protection V _{LoadDump} = UA + VS, UA=13.5V Ri=2Ω, RL=1Ω, td=400ms, IN=Low or High	V _{LoadDump} ²⁾	45	V	
Load current (Short-circuit current)	IL	Self-limited	V	
Operating temperature range	T _j	-40 ~ 150	°C	
Storage temperature range	T _{stg}	-55 ~ 150	°C	
Power Dissipation(DC)	P _{tot}	59	W	
Inductive load switch-off energy dissipation ³⁾ Single pulse, IL=10.7A, L=5mH, V _{bb} =12V, Tj=150°C	EAS	288	mJ	
Electrostatic discharge capability (ESD) (Human Body Model)	IS	V _{ESD}	2.8	KV
	IN	V _{ESD}	3	KV
	VBB, Output	V _{ESD}	5	KV
Current through input pin(DC)	I _{IN}	+15, -120	mA	
Current through current sense pin(DC)	I _{IS}	+15, -120	mA	
Input voltage slew rate V _{bb} ≤ 16V Input voltage slew rate V _{bb} > 16V ⁴⁾	dV _{bb} /dt	self-limited 20	V/us	

Note:

1) Short circuit is defined as a combination of remaining resistances and inductances. See schematic on page 11.

2) V_{Load dump} is setup without the DUT connected to the generator

3) See also diagram on page 11.

4) See also on page 7. Slew rate limitation can be achieved by means of using a series resistor R_{IN} in the input path. This resistor is also required for reverse operation. See also page 10.

Electrical Characteristics

At Tj=25°C, Vbb=12V unless otherwise specified.

Parameter	Symbol	Conditions	Min.	Typ.	Max.	Unit
Thermal Characteristics						
Thermal resistance	RthJC ⁵⁾	(junction to case)	-	-	1.0	K/W
	RthJA	(junction to ambient)	-	83	-	
		device on PCB ⁶⁾ , SMD version only	-	45	55	
Load Switching Capability and Characteristics						
On-state resistance(Pin3 to pin 1,5)	RON	VIN=0, Vbb=5.5V, IL=7.5A, Tj=25°C VIN=0, Vbb=5.5V, IL=7.5A, Tj=150°C VIN=0, Vbb=12V, IL=7.5A Tj=25°C VIN=0, Vbb=12V, IL=7.5A Tj=150°C	-	4.5 12 4.5 12	10 16 10 16	mΩ
Output voltage drop limitation at small load currents(tab to pin 1,5)	VON(NL)	Tj=-40 ~ 150°C	-	35	65	mV
Nominal load current(tab to pin1,5)	IL(ISO) IL(NOM)	ISO Proposal ⁶⁾ : VON<=0.5V, TC=85°C, Tj<=150°C SMD ^{6) 7)} : VON<= 0.5V, Ta=85°C, Tj<=150°C	33 10.5	41 12	- -	A
Turn-on time (to 90% VOUT)	ton	RL=2.2Ω, Tj = -40~ 150°C	-	160	400	us
Turn-off time (to 10% VOUT)	toff		-	110	400	
Slew rate on (25% to 50% VOUT)	dV / dt _{on}	RL=2.2Ω, Tj = -40~ 150°C	-	0.2	0.5	V/us
Slew rate off (50% to 25% VOUT)	-dV / dt _{off}	RL=2.2Ω, Tj = -40~ 150°C	-	0.3	0.65	V/us
Operating Parameters						
Operating Voltage(VIN=0)	Vbb(ON)	Tj = -40~ 150°C	5.5		38	V
Under voltage shutdown ^{7) 8)}	VbIN(u)		-	1.5	3.5	V
Under voltage restart of charge pump	Vbb(ucp)			3.7	5.5	V
Over voltage protection ⁹⁾	VZ,IN	Ibb=15mA, Tj = -40~ 150°C	42.5	47.3	-	V
Standby current	Ibb(off)	IIN=0, Tj = -40~ 120°C IIN=0, Tj = 150°C	- -	0.8 8	5.3 20	uA
Reverse Battery¹⁰⁾						
Reverse battery voltage	-Vbb		-	-	18	V
On-state resistance(Tab to pin 1,5) ⁸⁾	RON(REV)	Vbb=-8V, VIN=0, IL=-7.5A, RIS=1KΩ, Tj=25°C	-	9.5	13	mΩ
		Vbb=-8V, VIN=0, IL=-7.5A, RIS=1KΩ, Tj=150°C	-	15	22	
		Vbb=-12V, VIN=0, IL=-7.5A, RIS=1KΩ, Tj=25°C	-	5.5	10	
		Vbb=-12V, VIN=0, IL=-7.5A, RIS=1KΩ, Tj=150°C	-	12	16	
Integrated resistor in Vbb line	Rbb	Is=1mA, VIN=5V @125°C	65	95	125	Ω
Inverse operation¹¹⁾						
Output voltage drop(pin4 to pin 1, 5) ⁸⁾	-VON(inv)	IL=-10A, RIS=1KΩ, Tj=25°C	-	800	-	mV
		IL=-10A, RIS=1KΩ, Tj=150°C	-	600	-	
Turn-on delay after inverse operation;	td(inv)	IL> 0A ⁸⁾ VIN(inv)=VIN(fwd) = 0V	-	1	-	ms

Note:

5) Thermal resistance RthCH case to heatsink (about 0.5 ... 0.9 K/W with silicone paste) not included!

6) Device on 76.2mm * 114mm * 1.57mm glass epoxy PCB. still air condition.

7) Not subject to production test, Parameters are calculated from Ron and Rthjc or Rthja.

8) not subject to production test, specified by design

9) See also VON(CL) in circuit diagram page 8.

10) For operation at voltages higher than |16V| please see required schematic on page 9.

11) Permanent Inverse operation results eventually in a current flow via the intrinsic diode of the power DMOS. In this case the device switches on with a time delay td(inv) after the transition from inverse to forward mode.

Electrical Characteristics

At Tj=25°C, Vbb=12V unless otherwise specified

Parameter	Symbol	Conditions	Min.	Typ.	Max.	Unit
Protection Functions ¹²⁾						
Short circuit current limit (pin4 and tab to pin 1,5 at VON=6V ^{13) 14)}	IL6(SC)	Tj=-40°C Tj=25°C Tj=150°C	- - 65	100 90 80	130 - -	A
Short circuit current limit (pin4 and tab to pin 1,5 at VON=12V ¹³⁾	IL12(SC)	Tj=-40°C Tj=25°C Tj=150°C	- - 40	80 70 60	120 - -	A
Short circuit current limit (pin4 and tab to pin 1,5 at VON=18V ^{13) 14)}	IL18(SC)	Tj=-40°C Tj=25°C Tj=150°C	- - 33	63 55 47	81 - -	A
Short circuit current limit (pin4 and tab to pin 1,5 at VON=24V ¹³⁾	IL24(SC)	Tj=-40°C Tj=25°C Tj=150°C	- - 18	43 38 33	65 - -	A
Short circuit current limit (pin4 and tab to pin 1,5 at VON=30V ^{13) 14)}	IL30(SC)	Tj=-40°C Tj=25°C Tj=150°C	- - 7	25 24 23	50 -- -	A
Short circuit shutdown detection voltage	VON(SC)		2.5	3.5	4.5	V
Short circuit shutdown delay after input current positive slop Min value valid only if "off-signal" time exceeds 30us	td(SC1)	VON > VON(SC), Tj=-40 ~ 150°C	250	450	650	us
Output clamp(inductive load switch off) at VOUT= Vbb-VON(CL)(overvoltage) ¹⁵⁾	VON(CL)	IL=40mA	38.5	42	-	V
Thermal overload trip temperature	Tjt		150	175	-	°C
Thermal hysteresis	ΔTjt		-	10	-	K

notes:

12) Integrated protection functions are designed to prevent IC destruction under fault conditions described in the data sheet. Fault conditions are considered as "outside" normal operating range. Protection functions are not designed for continuous repetitive operation.

13) Short circuit current limit for max. duration of td(SC1) , prior to shutdown, see also figures 3b on page 15.

14) not subject to production test, specified by design

15) See also figure 2b on page 14.

Electrical Characteristics

Aat Tj=25°C, Vbb=12V unless otherwise specified.

Parameter	Symbol	Conditions	Min.	Typ.	Max.	Unit
Diagnostic Characteristics						
Current sense ratio, static on-condition KILIS = IL: IIS < IIS,min ¹⁶⁾ VIS < VOUT-5V, VbIN > 4.5V	KILIS	IL=30A, Tj=-40°C	-	11000	-	-
		IL=30A, Tj=25°C	8000	11000	13500	
		IL=30A, Tj=125°C	8000	10500	13000	
		IL=7.5A, Tj=-40°C	8000	10500	13000	
		IL=7.5A, Tj=25°C	5500	11000	16500	
		IL=7.5A, Tj=125°C	5500	11500	17000	
		IL=2.5A, Tj=-40°C	5500	11000	16500	
		IL=2.5A, Tj=25°C	5000	10500	17000	
		IL=2.5A, Tj=125°C	5000	11000	17500	
		IL=0.5A, Tj=-40°C	5000	12000	18500	
		IL=0.5A, Tj=25°C	4000	9900	18000	
		IL=0.5A, Tj=125°C	4000	11000	18000	
		IIN=0 (e.g. during deenergizing of inductive loads)		IL=0.5A, Tj=125°C	4000	12000
			-		-	
Sense current under fault conditions ¹⁷⁾	IIS,fault	VON > 1V,typ Tj=-40 ~ 150°C	4	6.2	9	mA
Sense saturation current	IIS,lim	VON < 1V,typ Tj=-40 ~ 150°C	4	7.5	9	mA
Fault-sense signal delay after input current positive slop	tdelay(fault)	VON > 1V,typ Tj=-40 ~ 150°C	250	450	650	us
Current sense leakage current	IIS(LL)	IIN = 0	-	0	0.5	uA
Current sense offset current	IIS(LH)	VIN = 0, IL <= 0	-	0	2	uA
Minimum load current for sense functionality	IL(MIN)	VIN = 0, Tj=-40 ~ 150°C	150	-	-	mA
Current sense settling time to IISstatic after input current positive slop ¹⁸⁾	tson(IS)	IL = 0 --> 20A, Tj=-40 ~ 150°C	-	300	650	us
Current sense settling timeduring on condition ¹⁸⁾	tslc(IS)	IL = 0 --> 20A, Tj=-40 ~ 150°C	-	50	100	us
Overvoltage protection	VZ,IS	Ibb=15mA, Tj=-40 ~ 150°C	42.5	47.3	-	V
Input						
Required current capability of input switch	IIN(on)	Tj=-40 ~ 150°C	-	1.5	3	mA
Input current for turn-off	IIN(off)	Tj=-40 ~ 150°C	-	-	15	uA

notes:

16) See also figures 4.x and 6.x on page 15 and 16.

17) Fault conditions are overload during on (i.e. VON>1V typ.), overtemperature and short circuit; see also truth table on page 7.

18) not subject to production test, specified by design

Application Information

1. Truth Table

Sense current under fault conditions	Input Current Level	Output Level	Current Sense
Normal operation	L	L	= 0 (IIS(LL))
	H	H	nominal
Overload ¹⁹⁾	L	L	= 0 (IIS(LL))
	H	H	IIS,fault
Short circuit to GND ²⁰⁾	L	L	= 0 (IIS(LL))
	H	L	IIS,fault
Overtemperature	L	L	= 0 (IIS(LL))
	H	L	IIS,fault
Short circuit to Vbb	L	H	= 0 (IIS(LL))
	H	H	< nominal ²¹⁾
Open load	L	Z	= 0 (IIS(LL))
	H	H	= 0 (IIS(LH))

L = "LOW" Level, Z = High impedance, potential depends on external circuit, H = "HIGH" Level

2. Terms

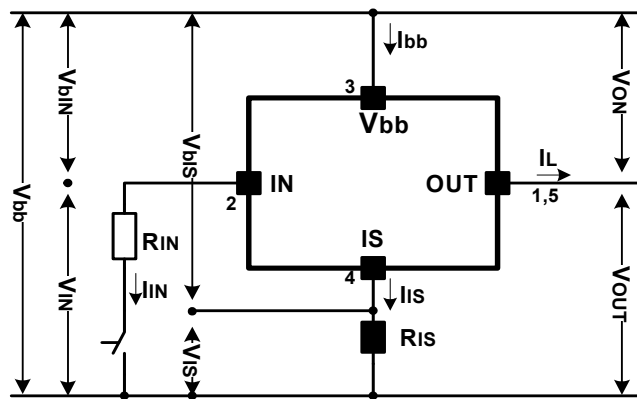

Notes:

19) Overload is detected at the following condition: $1V (typ.) < V_{ON} < 3.5V (typ.)$. See also page 10.

20) Short Circuit is detected at the following condition: $V_{ON} > 3.5V (typ.)$. See also page 11.

21) Low ohmic short to Vbb may reduce the output current I_L and therefore also the sense current I_{IS} .

3. Detailed Function Blocks

3.1 Input circuit(ESD protection)

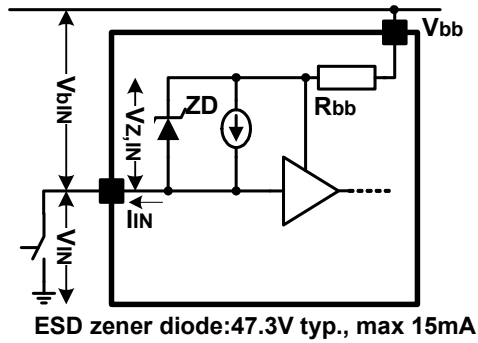

3.2 Current sense output

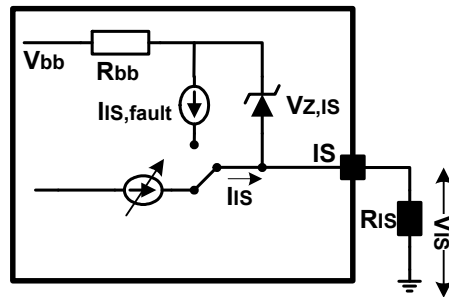

$V_{Z,IS} = 47.3\text{ V (typ.)}$, $R_{IS} = 1\text{K}\Omega$ nominal (or $1\text{K}\Omega/n$, if n devices are connected in parallel). $I_S = I_L/k_{IIS}$ can be only driven by the internal circuit as long as $V_{OUT} - V_{IS} > 5\text{V}$. Therefore R_{IS} should be less than

$$\frac{V_{bb} - 5\text{V}}{9\text{mA}}$$

Note: For large values of R_{IS} the voltage V_{IS} can reach almost V_{bb} . See also overvoltage protection. If you don't use the current sense output in your application, you can leave it open.

3.3 Inductive and overvoltage output clamp

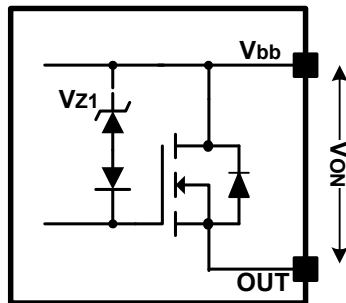

V_{ON} is clamped to $V_{ON(CL)} = 42\text{V typ}$

3.4 Overvoltage protection of logic part

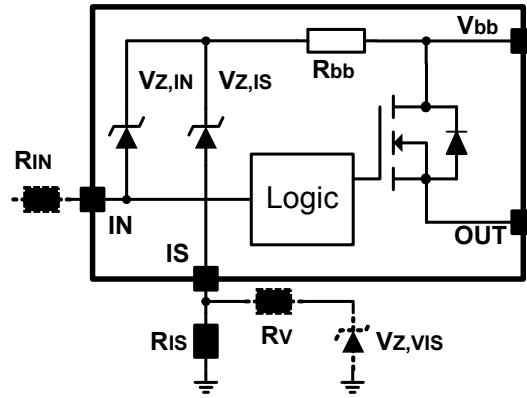

$R_{bb} = 95\Omega$ typ., $V_{Z,IN} = V_{Z,IS} = 47.3V$ typ., $R_{IS} = 1K\Omega$ nominal. Note that when overvoltage exceeds 47.3V typ. a voltage above 5V can occur between IS and GND, if R_V , $V_{Z,VIS}$ are not used.

3.5 Reverse battery protection

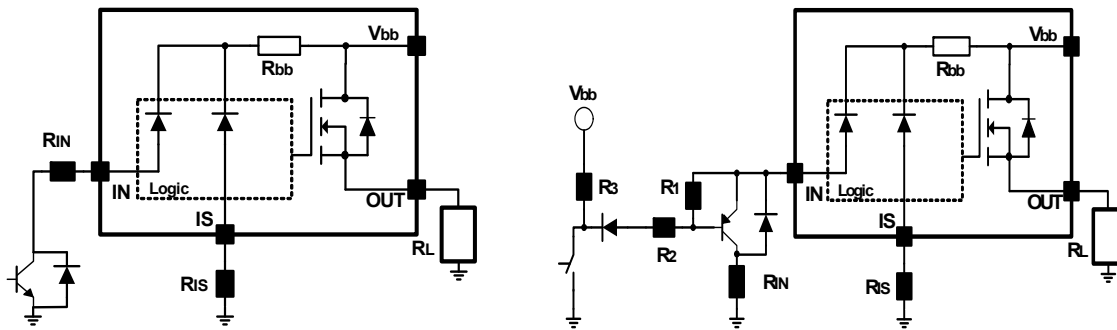

R_{IS} typ. $1K\Omega$. Add R_{IN} for reverse battery protection in application with V_{bb} above 16V;

$$\frac{1}{R_{IN}} + \frac{1}{R_{IS}} = \frac{0.082A}{|V_{bb} - 9V|}$$

To minimise power dissipation at reverse battery operation, the overall current into the IN and IS pin should be about 82mA. The current can be provided by using a small signal diode D in parallel to the input switch, by using a MOSFET input switch or by proper adjusting the current through R_{IS} . Since the current via R_{bb} generates additional heat in the device, this has to be taken into account in the overall thermal consideration.

3.6 Inverse load current operation

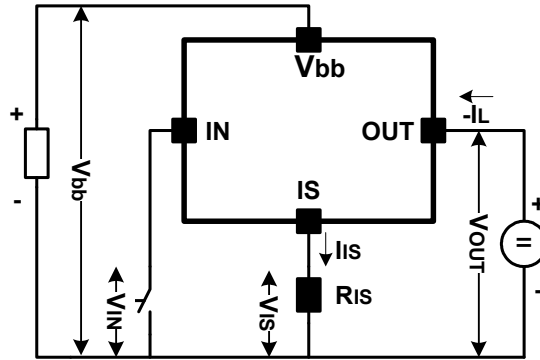

The device can be operated in inverse load current mode ($V_{OUT} > V_{bb} > 0V$). The current sense feature is not available during this kind of operation ($I_{IS} = 0$). In case of inverse operation the intrinsic drain source diode is eventually conducting resulting in considerably increased power dissipation. The transition from inverse to forward mode can result in a delayed switch on.

Note: Temperature protection during inverse load current operation is not possible!

3.7 Vbb disconnect with energised inductive load

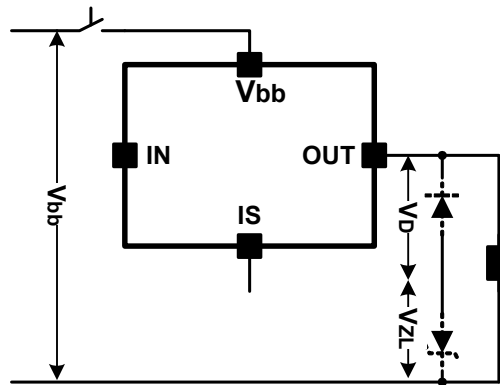

Provide a current path with load current capability by using a diode, a Z-diode, or a varistor. ($V_{ZL} + V_D < 38V$ if $R_{IN} = 0$). For higher clamp voltages currents at IN and IS have to be limited to 120 mA.

3.8 Overload detection

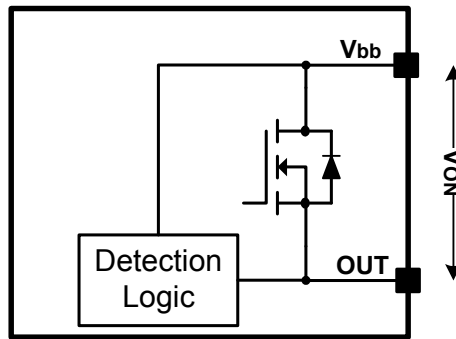

Fault Condition: $V_{ON} > 1V$ typ.

3.9 Short circuit

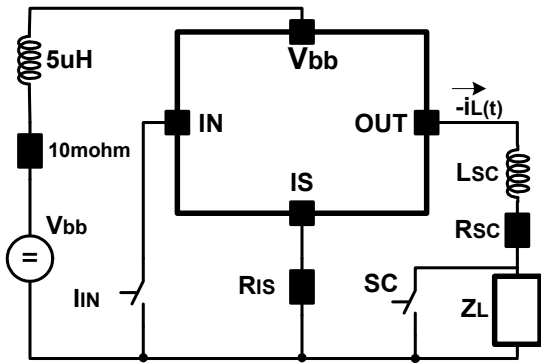

Fault Condition: $V_{ON} > V_{ON(SC)}$ (3.5V typ.) and $t > t_d(SC)$ (typ. 450us)

Short circuit is a combination of primary and secondary impedance's and a resistance's. Allowable combinations of minimum, secondary resistance for full protection at given secondary inductance and supply voltage for single short circuit event:

3.10 Inductive load switch-off energy dissipation

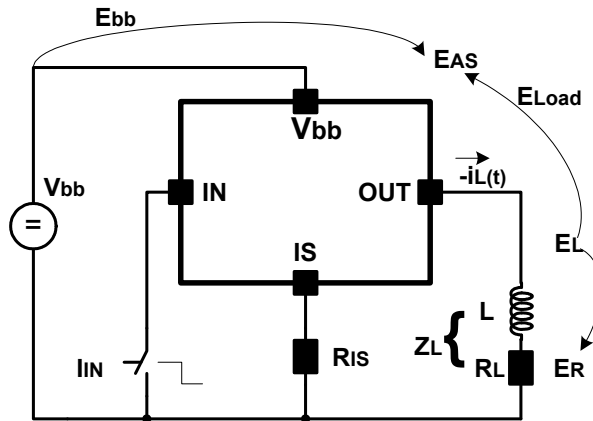

Energy stored in load inductance:

$$E_L = 1/2 \cdot L \cdot I_L^2$$

While demagnetizing load inductance, the energy dissipated in MOSFET is

$$E_{AS} = E_{bb} + E_L - E_R = \int V_{ON(CL)} \cdot i_L(t) dt$$

with an approximate solution for $R_L > 0$, $V_{out(CL)} = V_{on(CL)} - V_{bb}$:

$$E_{AS} = \frac{I_L \cdot L}{2 \cdot R_L} (V_{ON(CL)}) I_N \left(1 + \frac{I_L \cdot R_L}{|V_{OUT(CL)}|} \right)$$

3.11 Maximum allowable load inductance for a single switch off

$L=f(I_L)$; $T_j = 150^\circ\text{C}$, $V_{bb}=12\text{V}$, $R_L = 0\Omega$

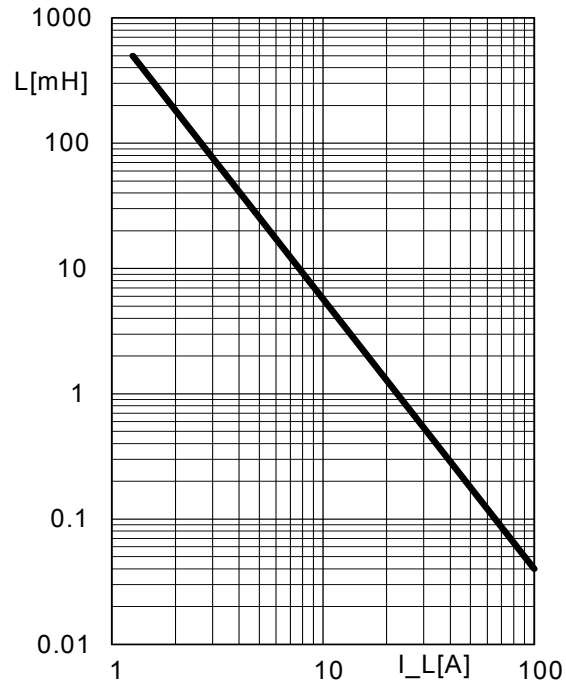

Typical Application Circuit

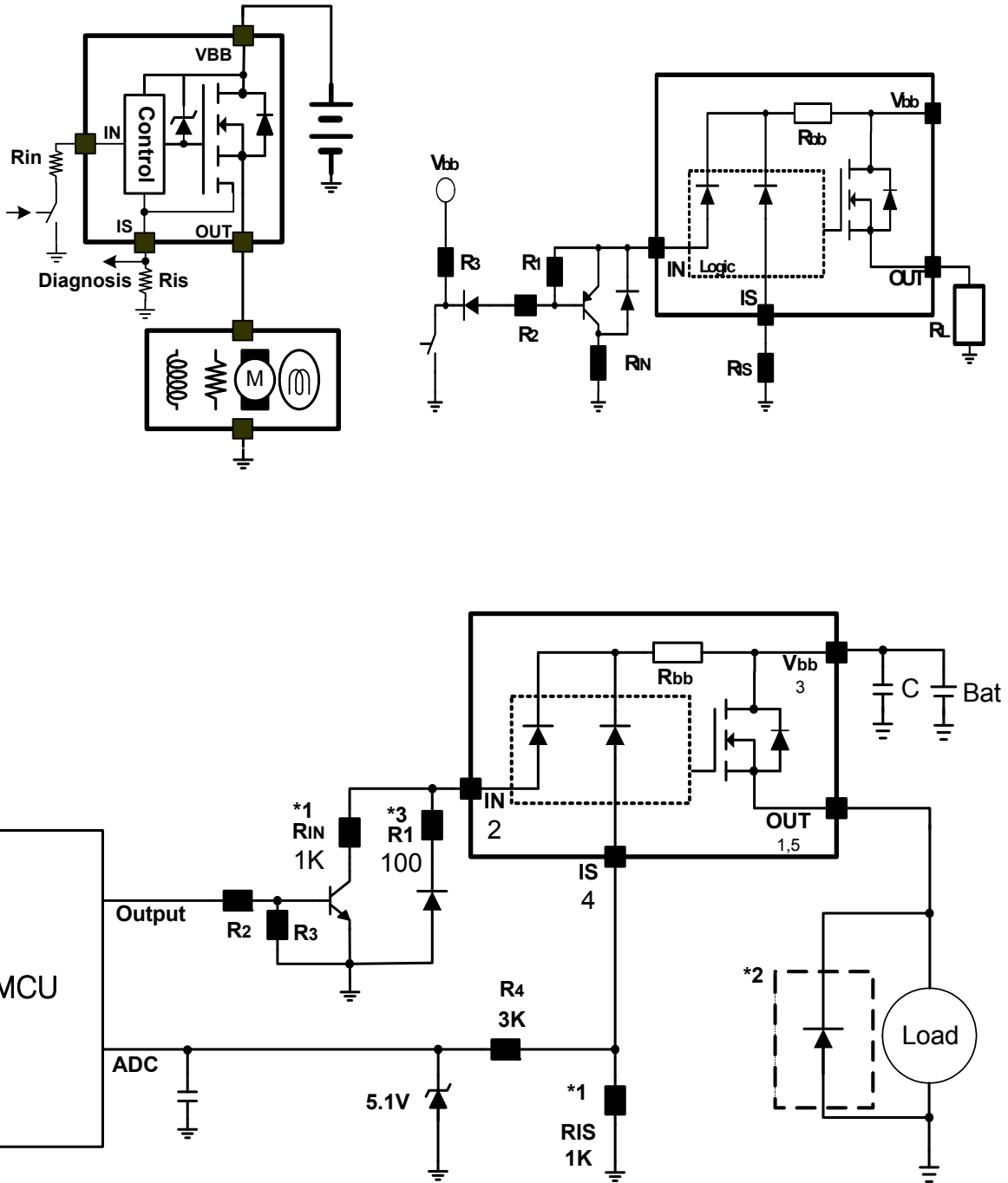

- 1) Ris and Rin is recommended as 1k
- 2) Put diode or capacitor between load to protect device or to remove noise.
- 3) For reverse battery protection function, R1 should be used less than 120Ω at -18V.

Timing Diagrams

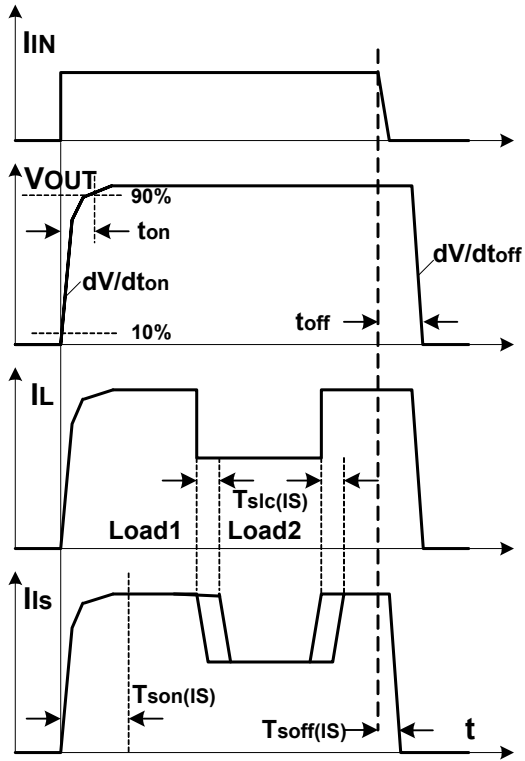

Figure 1a. Switching a resistive load, change of load current in on-condition

The sense signal is not valid during a setting time after turn-of/off and after change of load current

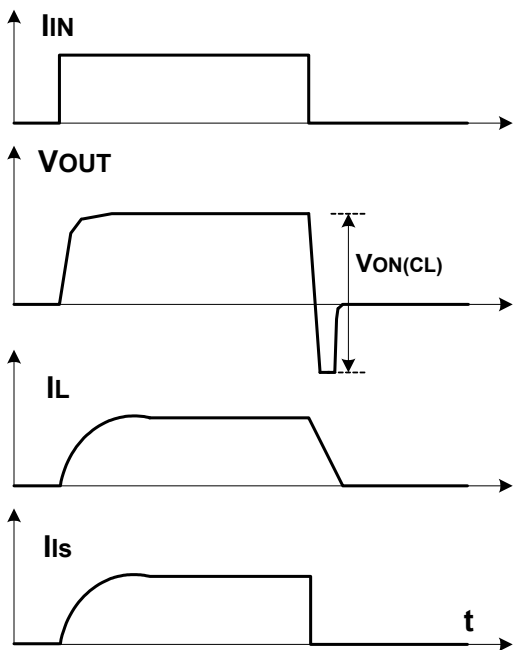

Figure 2b. Switching an inductive load

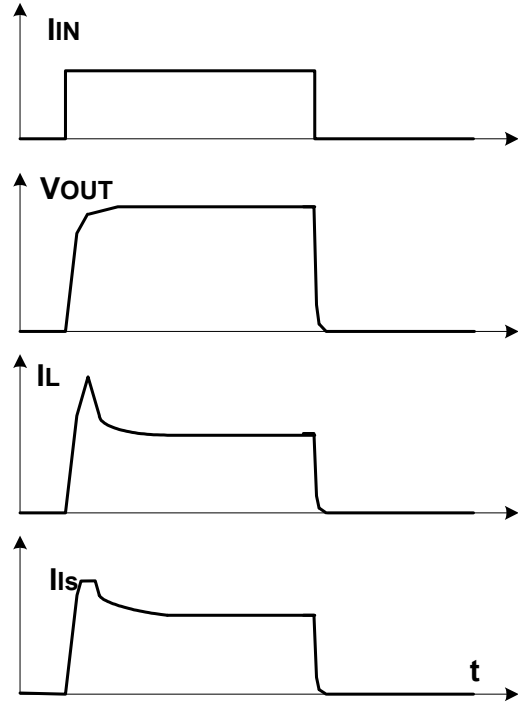

Figure 2a. Switching motors and lamps

As long as $V_{bIS} < V_{Z,IS}$ the sense current will never exceed $I_{IS,fault}$ and/or $I_{IS,lim}$

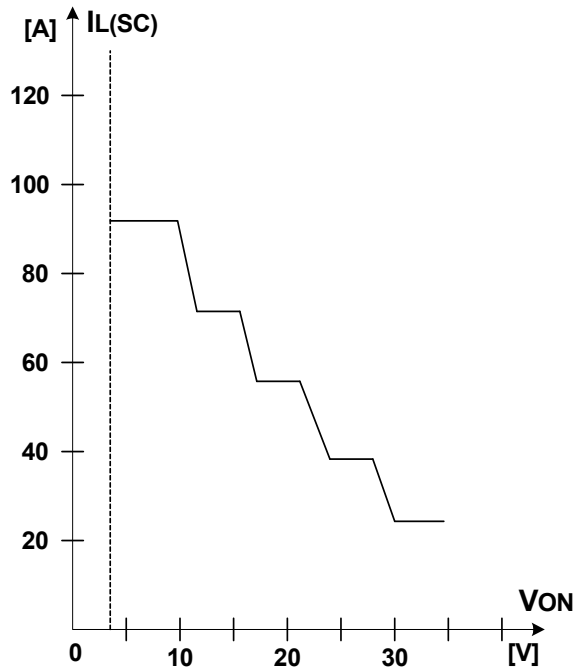

Figure 3a. Typ. current limitation characteristic

In case of $V_{ON} > V_{ON(SC)}$ (typ.3.5V) the device will be switched off by internal short circuit detection

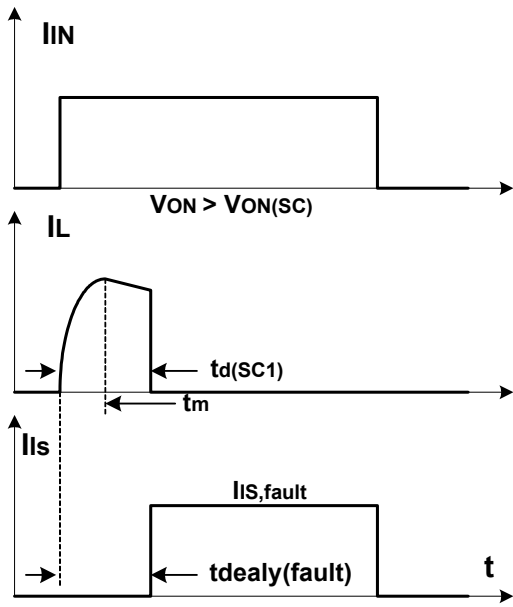

Figure 3b. Short circuit type one:
shut down by short circuit detection, reset by IIN=0

Shut down remains latched until next reset via input

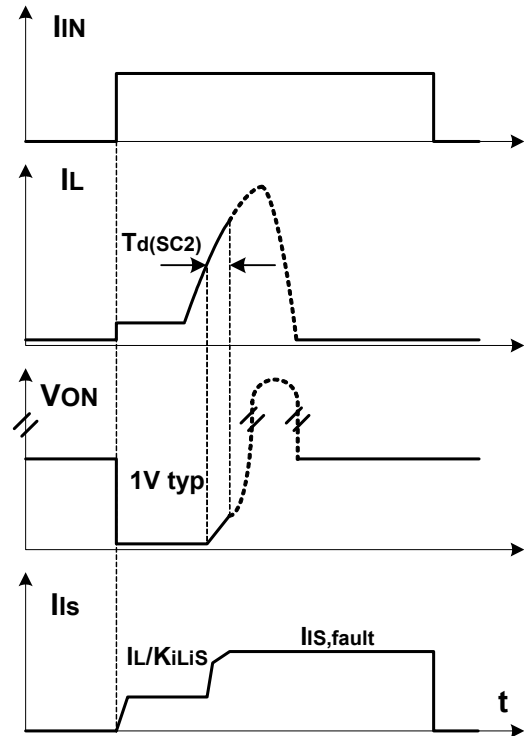

Figure 3c. Short circuit type two:
shut down by short circuit detection, reset by IIN=0

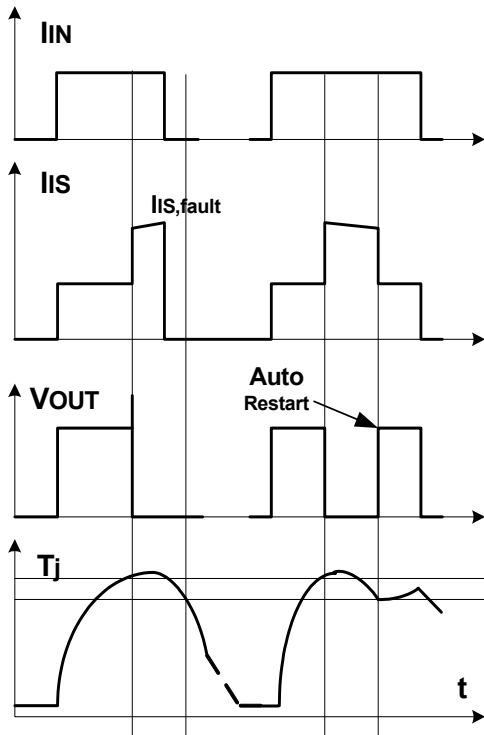

Figure 4a. Overtemperature Reset if $T_j < T_{jt}$

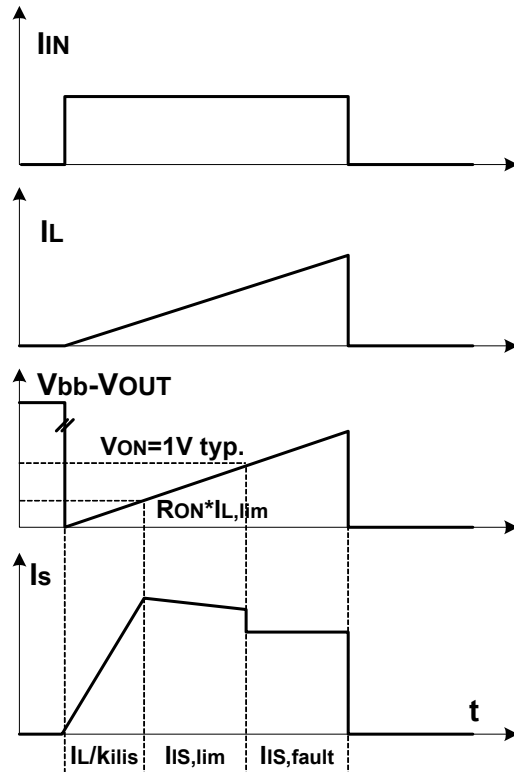

Figure 4b. Overload Reset if $T_j < T_{jt}$

3.VB Drop Voltage Diagram

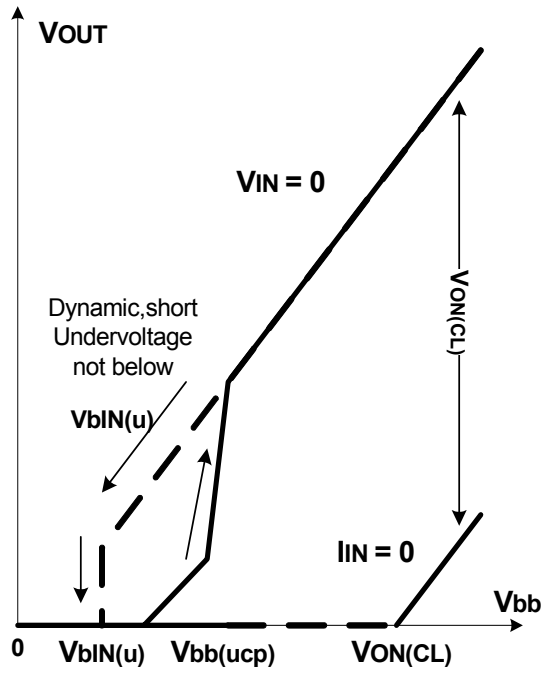

Figure 5. Undervoltage restart of charge pump overvoltage clamp

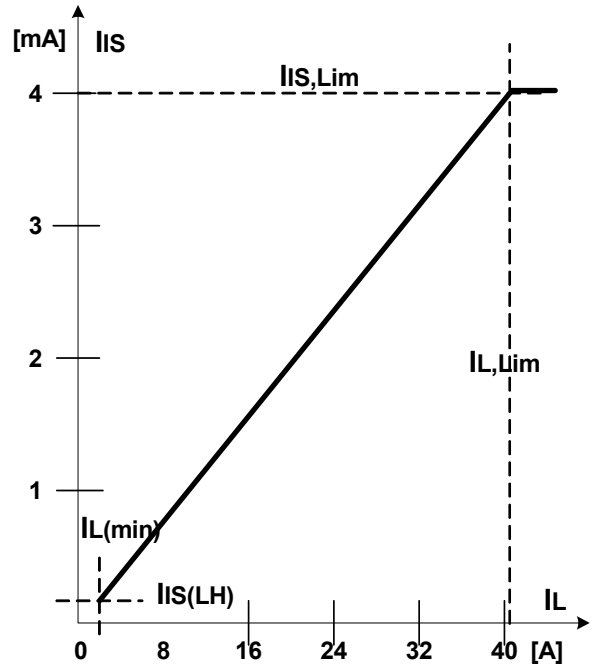

Figure 6a. Current sense versus load current

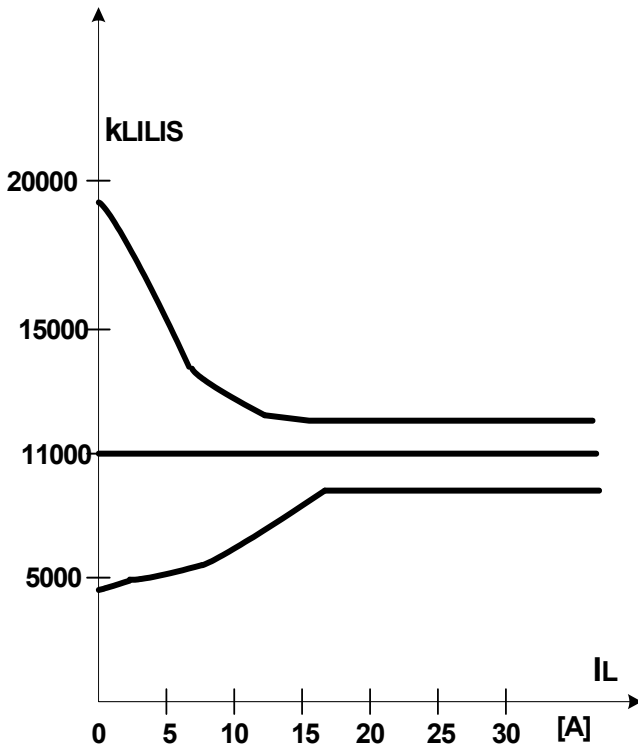

Figure 6b. Current sense ratio

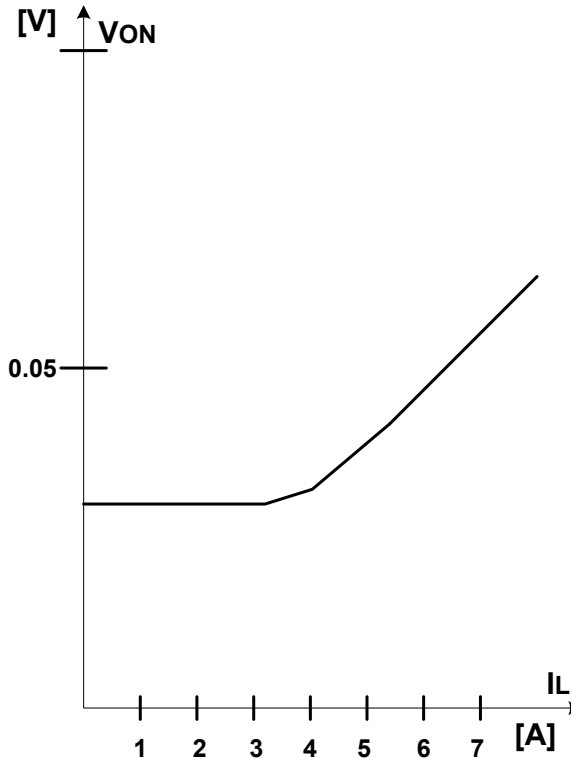
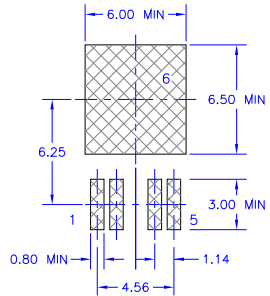
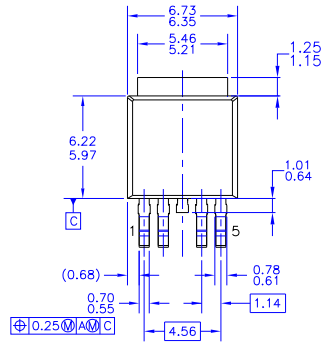

Figure 7. Output voltage drop versus load current

Package Dimensions

THIS DRAWING IS THE PROPERTY OF FAIRCHILD SEMICONDUCTOR CORPORATION AND USE THEREOF SHALL BE MADE STRICTLY IN ACCORDANCE WITH THE TERMS AND CONDITIONS OF THE LICENSE AGREEMENT. NO PART OF THIS DRAWING SHALL BE REPRODUCED OR TRANSMITTED IN ANY FORM OR BY ANY MEANS, ELECTRONIC OR MECHANICAL, INCLUDING PHOTOCOPYING, RECORDING, OR BY ANY INFORMATION STORAGE AND RETRIEVAL SYSTEM, WITHOUT THE WRITTEN PERMISSION OF FAIRCHILD SEMICONDUCTOR CORPORATION. THE INFORMATION CONTAINED ON THIS DRAWING IS CONFIDENTIAL AND PROPRIETARY.

REVISIONS				
REV	DESCRIPTION	E.G.N.	DATE	BY/APP'D
1	RELEASE TO DOCUMENT CONTROL		05APR2006	OS JEON



LAND PATTERN RECOMMENDATION

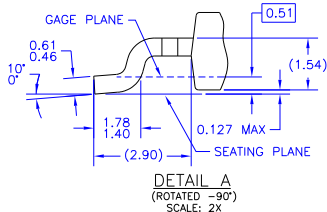
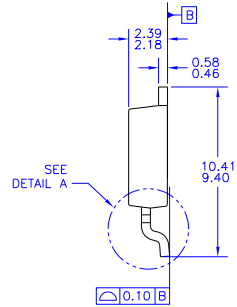
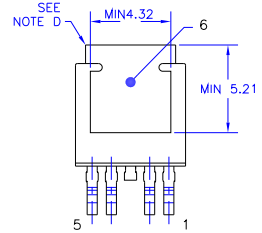

- NOTES: UNLESS OTHERWISE SPECIFIED
 A) THIS PACKAGE CONFORMS TO JEDEC TO-252 ISSUE E, VARIATION AD, DATED JUNE, 2004.
 B) ALL DIMENSIONS ARE IN MILLIMETERS.
 C) DIMENSIONS ARE EXCLUSIVE OF BURRS, MOLD FLASH, AND TIE BAR EXTRUSIONS.
 D) HEAT SINK TOP EDGE COULD BE IN CHAMFERED CORNERS OR EDGE PROTRUSION.
 E) DIMENSIONS AND TOLERANCES PER ASME Y14.5M-1994

FILE NAME

APPROVALS	DATE	 BUCHEON KOREA
DESIGNED: S. W LIM	05APR2006	
DRAWN: S. W LIM		
APPROVED: M.K JONG		
O.S JEON		TO-252 MOLDED, 5LD JEDEC TO-252, AD
PROJECTION	SCALE	REV
	1:1	0
FORMERLY: N/A	SIZE	DRAWING NUMBER
	NA	MKT-
		SHEET : 1 OF 1

TRADEMARKS

The following are registered and unregistered trademarks Fairchild Semiconductor owns or is authorized to use and is not intended to be an exhaustive list of all such trademarks.

ACEx™	FACT Quiet Series™	ISOPLANAR™	POP™	SuperFET™
ActiveArray™	FAST®	LittleFET™	Power247™	SuperSOT™-3
Bottomless™	FASTr™	MICROCOUPLER™	PowerTrench®	SuperSOT™-6
CoolFET™	FPS™	MicroFET™	QFET®	SuperSOT™-8
CROSSVOLT™	FRFET™	MicroPak™	QS™	SyncFET™
DOME™	GlobalOptoisolator™	MICROWIRE™	QT Optoelectronics™	TinyLogic®
EcoSPARK™	GTO™	MSX™	Quiet Series™	TINYOPTO™
E ² CMOS™	HiSeC™	MSXPro™	RapidConfigure™	TruTranslation™
EnSigna™	IC™	OCX™	RapidConnect™	UHC™
FACT™	ImpliedDisconnect™	OCXPro™	SILENT SWITCHER®	UltraFET®
Across the board. Around the world.™		OPTOLOGIC®	SMART START™	VCX™
The Power Franchise™		OPTOPLANAR™	SPM™	
Programmable Active Droop™		PACMAN™	Stealth™	

DISCLAIMER

FAIRCHILD SEMICONDUCTOR RESERVES THE RIGHT TO MAKE CHANGES WITHOUT FURTHER NOTICE TO ANY PRODUCTS HEREIN TO IMPROVE RELIABILITY, FUNCTION OR DESIGN. FAIRCHILD DOES NOT ASSUME ANY LIABILITY ARISING OUT OF THE APPLICATION OR USE OF ANY PRODUCT OR CIRCUIT DESCRIBED HEREIN; NEITHER DOES IT CONVEY ANY LICENSE UNDER ITS PATENT RIGHTS, NOR THE RIGHTS OF OTHERS.

LIFE SUPPORT POLICY

FAIRCHILD'S PRODUCTS ARE NOT AUTHORIZED FOR USE AS CRITICAL COMPONENTS IN LIFE SUPPORT DEVICES OR SYSTEMS WITHOUT THE EXPRESS WRITTEN APPROVAL OF FAIRCHILD SEMICONDUCTOR CORPORATION. As used herein:

1. Life support devices or systems are devices or systems which, (a) are intended for surgical implant into the body, or (b) support or sustain life, or (c) whose failure to perform when properly used in accordance with instructions for use provided in the labeling, can be reasonably expected to result in significant injury to the user.
2. A critical component is any component of a life support device or system whose failure to perform can be reasonably expected to cause the failure of the life support device or system, or to affect its safety or effectiveness.

PRODUCT STATUS DEFINITIONS

Definition of Terms

Datasheet Identification	Product Status	Definition
Advance Information	Formative or In Design	This datasheet contains the design specifications for product development. Specifications may change in any manner without notice.
Preliminary	First Production	This datasheet contains preliminary data, and supplementary data will be published at a later date. Fairchild Semiconductor reserves the right to make changes at any time without notice in order to improve design.
No Identification Needed	Full Production	This datasheet contains final specifications. Fairchild Semiconductor reserves the right to make changes at any time without notice in order to improve design.
Obsolete	Not In Production	This datasheet contains specifications on a product that has been discontinued by Fairchild semiconductor. The datasheet is printed for reference information only.

Rev. 17

Looking for pricing, stock, or lifecycle information?

Click below to explore more details on WIN SOURCE:

- ⊖ [View FDDS10H04A_F085A on WIN SOURCE](#)
- ⊖ [Fairchild/ON Semiconductor Information](#)

Optimize Your Supply Chain with WIN SOURCE Solutions

- ✓ Global Sourcing Solution
- ✓ Obsolete Management
- ✓ Cost Control Management
- ✓ Shortage Management
- ✓ Alternative Solution
- ✓ Excess Inventory Management