

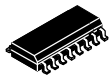

**THE DATASHEET OF
SN65MLVD047PWR**





MULTIPOINT-LVDS QUAD DIFFERENTIAL LINE DRIVER

FEATURES

- Differential Line Drivers for 30-Ω to 55-Ω Loads and Data Rates⁽¹⁾ Up to 200 Mbps, Clock Frequencies up to 100 MHz
- Supports Multipoint Bus Architectures
- Operates from a Single 3.3-V Supply
- Characterized for Operation from –40°C to 85°C
- 16-Pin SOIC (JEDEC MS-012) and 16-Pin TSSOP (JEDEC MS-153) Packaging

APPLICATIONS

- Clock Distribution
- Backplane or Cabled Multipoint Data Transmission in Telecommunications, Automotive, Industrial, and Other Computer Systems
- Cellular Base Stations
- Central-Office and PBX Switching
- Bridges and Routers
- Low-Power High-Speed Short-Reach Alternative to TIA/EIA-485⁽¹⁾

(1) The data rate of a line is the number of voltage transitions that are made per second expressed in the units bps (bits per second).

DESCRIPTION

The SN65MLVD047 is a quadruple line driver. The output current of this device has been increased, in comparison to standard LVDS compliant devices, in order to support doubly terminated transmission lines and heavily loaded backplane bus applications. Backplane applications generally require impedance matching termination resistors at both ends of the bus. The effective impedance of a doubly terminated bus can be as low as 30 Ω due to the bus terminations, as well as the capacitive load of bus interface devices. SN65MLVD047 drivers allow for operation with loads as low as 30 Ω. The SN65MLVD047 devices allow for multiple drivers to be present on a single bus. Driver edge rate control is incorporated to support operation. The SN65MLVD047 provides 9-kV ESD protection on all bus pins.

LOGIC DIAGRAM (POSITIVE LOGIC)

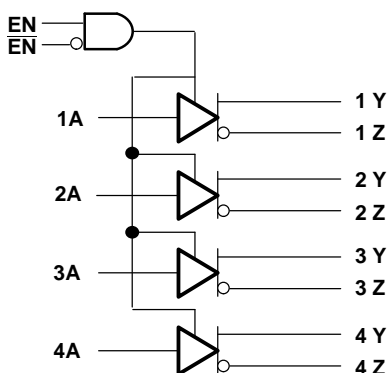

Please be aware that an important notice concerning availability, standard warranty, and use in critical applications of Texas Instruments semiconductor products and disclaimers thereto appears at the end of this data sheet.



These devices have limited built-in ESD protection. The leads should be shorted together or the device placed in conductive foam during storage or handling to prevent electrostatic damage to the MOS gates.

ORDERING INFORMATION

PART NUMBER	PACKAGE MARKING	PACKAGE/CARRIER
SN65MLVD047D	MLVD047	16-Pin SOIC/Tube
SN65MLVD047DR	MLVD047	16-Pin SOIC/Tape and Reel
SN65MLVD047PW	MLVD047	16-Pin TSSOP/Tube
SN65MLVD047PWR	MLVD047	16-Pin TSSOP/Tape and Reel

PACKAGE DISSIPATION RATINGS

PACKAGE	PCB JEDEC STANDARD	$T_A \leq 25^\circ\text{C}$ POWER RATING	DERATING FACTOR ABOVE $T_A = 25^\circ\text{C}$ ⁽¹⁾	$T_A = 85^\circ\text{C}$ POWER RATING
D(16)	Low-K ⁽²⁾	898 mW	7.81 mW/°C	429 mW
PW(16)	Low-K ⁽²⁾	592 mW	5.15 mW/°C	283 mw
	High-K ⁽³⁾	945 mW	8.22 mW/°C	452 mw

(1) This is the inverse of the junction-to-ambient thermal resistance when board mounted and with no air flow.

(2) In accordance with the Low-K thermal metric definitions of EIA/JESD51-3.

(3) In accordance with the High-K thermal metric definitions of EIA/JESD51-7.

ABSOLUTE MAXIMUM RATINGS

over operating free-air temperature range unless otherwise noted⁽¹⁾

			UNITS
V_{CC}	Supply voltage range ⁽²⁾		–0.5 V to 4 V
V_I	Input voltage range	A, EN, $\overline{\text{EN}}$	–0.5 V to 4 V
V_O	Output voltage range	Y, Z	–1.8 V to 4 V
Electrostatic discharge	Human Body Model ⁽³⁾	Y and Z	±9 kV
		All pins	±4 kV
	Charged-Device Model ⁽⁴⁾	All pins	±1500 V
	Machine Model ⁽⁵⁾	All pins	200 V
T_J	Junction temperature		140°C
P_D	Continuous power dissipation		See Dissipation Rating Table

(1) Stresses beyond those listed under *absolute maximum ratings* may cause permanent damage to the device. These are stress ratings only, and functional operation of the device at these or any other conditions beyond those indicated under *recommended operating conditions* is not implied. Exposure to absolute-maximum-rated conditions for extended periods may affect device reliability.

(2) All voltage values, except differential I/O bus voltages, are with respect to the circuit ground terminal.

(3) Tested in accordance with JEDEC Standard 22, Test Method A114-B.

(4) Tested in accordance with JEDEC Standard 22, Test Method C101-A.

(5) Tested in accordance with JEDEC Standard 22, Test Method A115-A.

RECOMMENDED OPERATING CONDITIONS (see Figure 1)

		MIN	NOM	MAX	UNIT
V_{CC}	Supply voltage	3	3.3	3.6	V
V_{IH}	High-level input voltage	2		V_{CC}	V
V_{IL}	Low-level input voltage	0		0.8	V
	Voltage at any bus terminal (separate or common mode) V_Y or V_Z	-1.4		3.8	V
R_L	Differential load resistance	30		55	Ω
$1/t_{UI}$	Signaling rate			200	Mbps
	Clock frequency			100	MHz
T_J	Junction temperature	-40		125	$^{\circ}\text{C}$

THERMAL CHARACTERISTICS

PARAMETER		TEST CONDITIONS		MIN	TYP	MAX	UNIT
θ_{JA}	Junction-to-ambient thermal resistance	Low-K board ⁽¹⁾ , no airflow	D		128		$^{\circ}\text{C}/\text{W}$
		Low-K board ⁽¹⁾ , no airflow	PW		194.2		
		Low-K board ⁽¹⁾ , 150 LFM			146.8		
		Low-K board ⁽¹⁾ , 250 LFM			133.1		
		High-K board ⁽²⁾ , no airflow			121.6		
θ_{JB}	Junction-to-board thermal resistance	High-K board ⁽²⁾	D		51.1		$^{\circ}\text{C}/\text{W}$
			PW		85.3		
θ_{JC}	Junction-to-case thermal resistance		D		45.4		$^{\circ}\text{C}/\text{W}$
			PW		34.7		
P_D	Device power dissipation	EN = V_{CC} , $\overline{\text{EN}}$ = GND, $R_L = 50 \Omega$, Input 100 MHz 50 % duty cycle square wave to 1A:4A, $T_A = 85^{\circ}\text{C}$				288.5	mW

- (1) In accordance with the Low-K thermal metric definitions of EIA/JESD51-3.
 (2) In accordance with the High-K thermal metric definitions of EIA/JESD51-7.

DEVICE ELECTRICAL CHARACTERISTICS

over recommended operating conditions unless otherwise noted

PARAMETER		TEST CONDITIONS		MIN ⁽¹⁾	TYP ⁽²⁾	MAX	UNIT
I_{CC}	Supply current	Driver enabled	EN = V_{CC} , $\overline{\text{EN}}$ = GND, $R_L = 50 \Omega$, All inputs = V_{CC} or GND		59	70	mA
	Driver disabled	EN = GND, $\overline{\text{EN}}$ = V_{CC} , $R_L = \text{No load}$, All inputs = V_{CC} or GND		2	4		

- (1) The algebraic convention, in which the least positive (most negative) limit is designated as minimum is used in this data sheet.
 (2) All typical values are at 25°C and with a 3.3-V supply voltage.

DEVICE ELECTRICAL CHARACTERISTICS

over recommended operating conditions unless otherwise noted

PARAMETER		TEST CONDITIONS	MIN ⁽¹⁾	TYP ⁽²⁾	MAX	UNIT
LVTTTL (EN, EN̄, 1A:4A)						
$ I_{IH} $	High-level input current	$V_{IH} = 2\text{ V or }V_{CC}$	0		10	μA
$ I_{IL} $	Low-level input current	$V_{IL} = \text{GND or }0.8\text{ V}$	0		10	μA
C_i	Input capacitance	$V_I = 0.4 \sin(30E6\pi t) + 0.5\text{ V}^{(3)}$		5		pF
M-LVDS (1Y/1Z:4Y/4Z)						
$ V_{YZ} $	Differential output voltage magnitude	See Figure 2	480		650	mV
$\Delta V_{YZ} $	Change in differential output voltage magnitude between logic states		-50		50	mV
$V_{OS(SS)}$	Steady-state common-mode output voltage	See Figure 3	0.8		1.2	V
$\Delta V_{OS(SS)}$	Change in steady-state common-mode output voltage between logic states		-50		50	mV
$V_{OS(PP)}$	Peak-to-peak common-mode output voltage				150	mV
$V_{Y(OC)}$	Maximum steady-state open-circuit output voltage	See Figure 7	0		2.4	V
$V_{Z(OC)}$	Maximum steady-state open-circuit output voltage		0		2.4	V
$V_{P(H)}$	Voltage overshoot, low-to-high level output	See Figure 5			$1.2 V_{SS}$	V
$V_{P(L)}$	Voltage overshoot, high-to-low level output		$-0.2 V_{SS}$			V
$ I_{OS} $	Differential short-circuit output current magnitude	See Figure 4			24	mA
I_{OZ}	High-impedance state output current	$-1.4\text{ V} \leq (V_Y \text{ or } V_Z) \leq 3.8\text{ V}$, Other output = 1.2 V	-15		10	μA
$I_{O(OFF)}$	Power-off output current	$-1.4\text{ V} \leq (V_Y \text{ or } V_Z) \leq 3.8\text{ V}$, Other output = 1.2 V, $V_{CC} = 0\text{ V}$	-10		10	μA
C_Y or C_Z	Output capacitance	$V_Y \text{ or } V_Z = 0.4 \sin(30E6\pi t) + 0.5\text{ V}$, ⁽³⁾ Other input at 1.2 V, driver disabled		3		pF
C_{YZ}	Differential output capacitance	$V_{YZ} = 0.4 \sin(30E6\pi t)\text{ V}$, ⁽³⁾ Driver disabled			2.5	pF
$C_{Y/Z}$	Output capacitance balance, (C_Y/C_Z)		0.99	1.01		

(1) The algebraic convention, in which the least positive (most negative) limit is designated as minimum is used in this data sheet.

(2) All typical values are at 25°C and with a 3.3-V supply voltage.

(3) HP4194A impedance analyzer (or equivalent)

SWITCHING CHARACTERISTICS

over recommended operating conditions unless otherwise noted

PARAMETER		TEST CONDITIONS	MIN	TYP ⁽¹⁾	MAX	UNIT	
t_{PLH}	Propagation delay time, low-to-high-level output	See Figure 5	1	1.5	2.4	ns	
t_{PHL}	Propagation delay time, high-to-low-level output		1	1.5	2.4	ns	
t_r	Differential output signal rise time		1		1.9	ns	
t_f	Differential output signal fall time		1		1.9	ns	
$t_{sk(o)}$	Output skew				100	ps	
$t_{sk(p)}$	Pulse skew ($ t_{pHL} - t_{pLH} $)			22	100	ps	
$t_{sk(pp)}$	Part-to-part skew ⁽²⁾				600	ps	
$t_{jit(per)}$	Period jitter, rms (1 standard deviation) ⁽³⁾		All inputs 100 MHz clock input		0.2	1	ps
$t_{jit(c-c)}$	Cycle-to-cycle jitter ⁽³⁾		All inputs 100 MHz clock input		5	36	ps
$t_{jit(pp)}$	Peak-to-peak jitter ⁽³⁾⁽⁴⁾		All inputs 200 Mbps 2 ¹⁵ -1 PRBS input		46	158	ps
t_{PZH}	Enable time, high-impedance-to-high-level output	See Figure 6			7	ns	
t_{PZL}	Enable time, high-impedance-to-low-level output				7	ns	
t_{PHZ}	Disable time, high-level-to-high-impedance output	See Figure 6			8	ns	
t_{PLZ}	Disable time, low-level-to-high-impedance output				8	ns	

(1) All typical values are at 25°C and with a 3.3-V supply voltage.

(2) $t_{sk(pp)}$ is the magnitude of the difference in propagation delay times between any specified terminals of two devices when both devices operate with the same supply voltages, at the same temperature, and have identical packages and test circuits.

(3) Stimulus jitter has been subtracted from the measurements.

(4) Peak-to-peak jitter includes jitter due to pulse skew ($t_{sk(p)}$).

PARAMETER MEASUREMENT INFORMATION

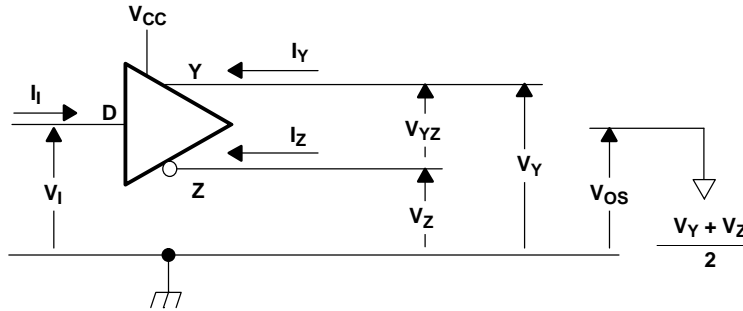
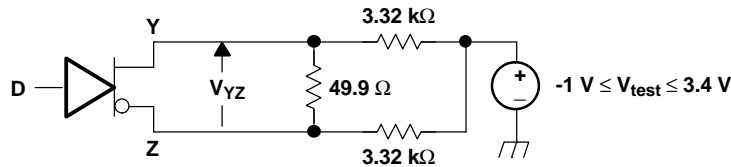
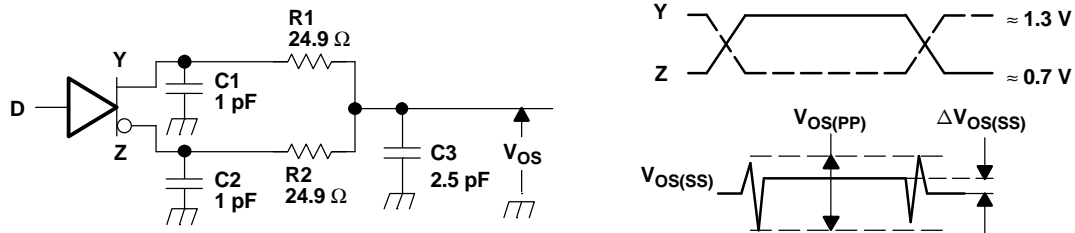

Figure 1. Driver Voltage and Current Definitions



NOTE: All resistors are 1% tolerance.

Figure 2. Differential Output Voltage Test Circuit



- A. All input pulses are supplied by a generator having the following characteristics: t_r or $t_f \leq 1$ ns, pulse frequency = 500 kHz, duty cycle = $50 \pm 5\%$.
- B. C1, C2 and C3 include instrumentation and fixture capacitance within 2 cm of the D.U.T. and are $\pm 20\%$.
- C. R1 and R2 are metal film, surface mount, $\pm 1\%$, and located within 2 cm of the D.U.T.
- D. The measurement of $V_{OS(PP)}$ is made on test equipment with a -3 dB bandwidth of at least 1 GHz.

Figure 3. Test Circuit and Definitions for the Common-Mode Output Voltage

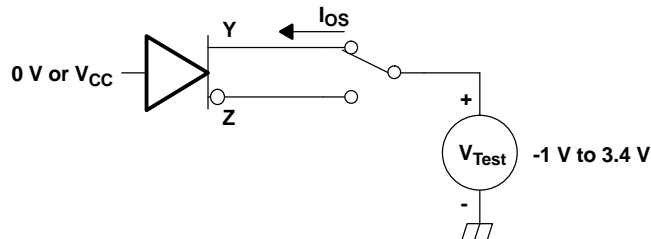
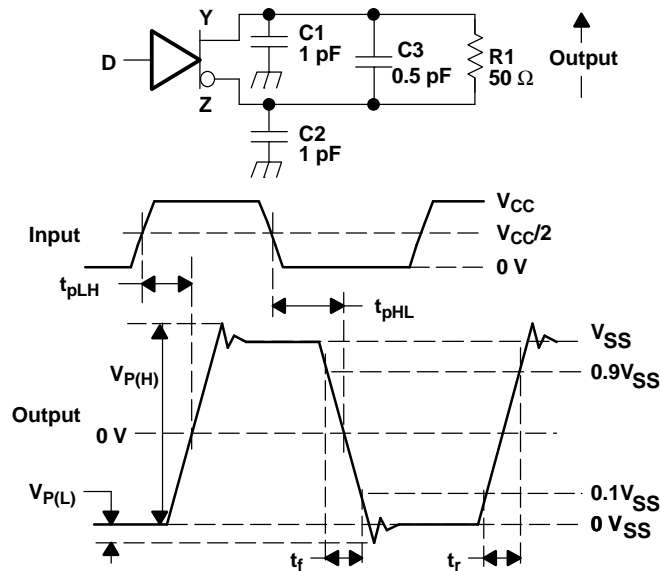

Figure 4. Short-Circuit Test Circuit

PARAMETER MEASUREMENT INFORMATION (continued)



- A. All input pulses are supplied by a generator having the following characteristics: t_r or $t_f \leq 1$ ns, frequency = 500 kHz, duty cycle = $50 \pm 5\%$.
- B. C1, C2, and C3 include instrumentation and fixture capacitance within 2 cm of the D.U.T. and are $\pm 20\%$.
- C. R1 is a metal film, surface mount, and 1% tolerance and located within 2 cm of the D.U.T.
- D. The measurement is made on test equipment with a -3 dB bandwidth of at least 1 GHz.

Figure 5. Driver Test Circuit, Timing, and Voltage Definitions for the Differential Output Signal

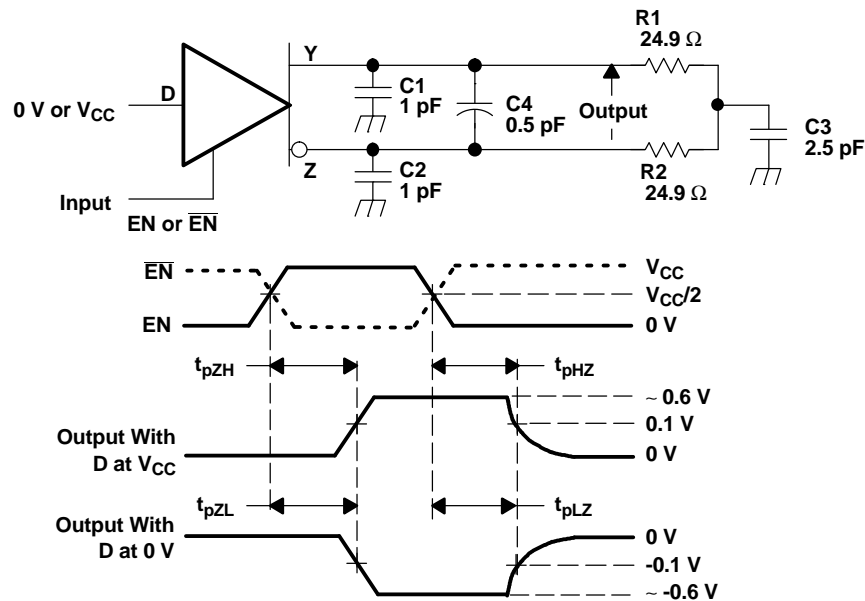

- A. All input pulses are supplied by a generator having the following characteristics: t_r or $t_f \leq 1$ ns, frequency = 500 kHz, duty cycle = $50 \pm 5\%$.
- B. C1, C2, C3, and C4 includes instrumentation and fixture capacitance within 2 cm of the D.U.T. and are $\pm 20\%$.
- C. R1 and R2 are metal film, surface mount, and 1% tolerance and located within 2 cm of the D.U.T.
- D. The measurement is made on test equipment with a -3 dB bandwidth of at least 1 GHz.

Figure 6. Driver Enable and Disable Time Circuit and Definitions

PARAMETER MEASUREMENT INFORMATION (continued)

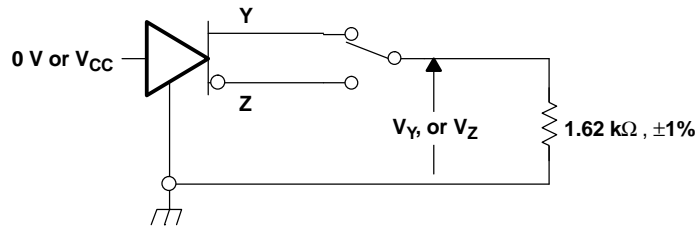
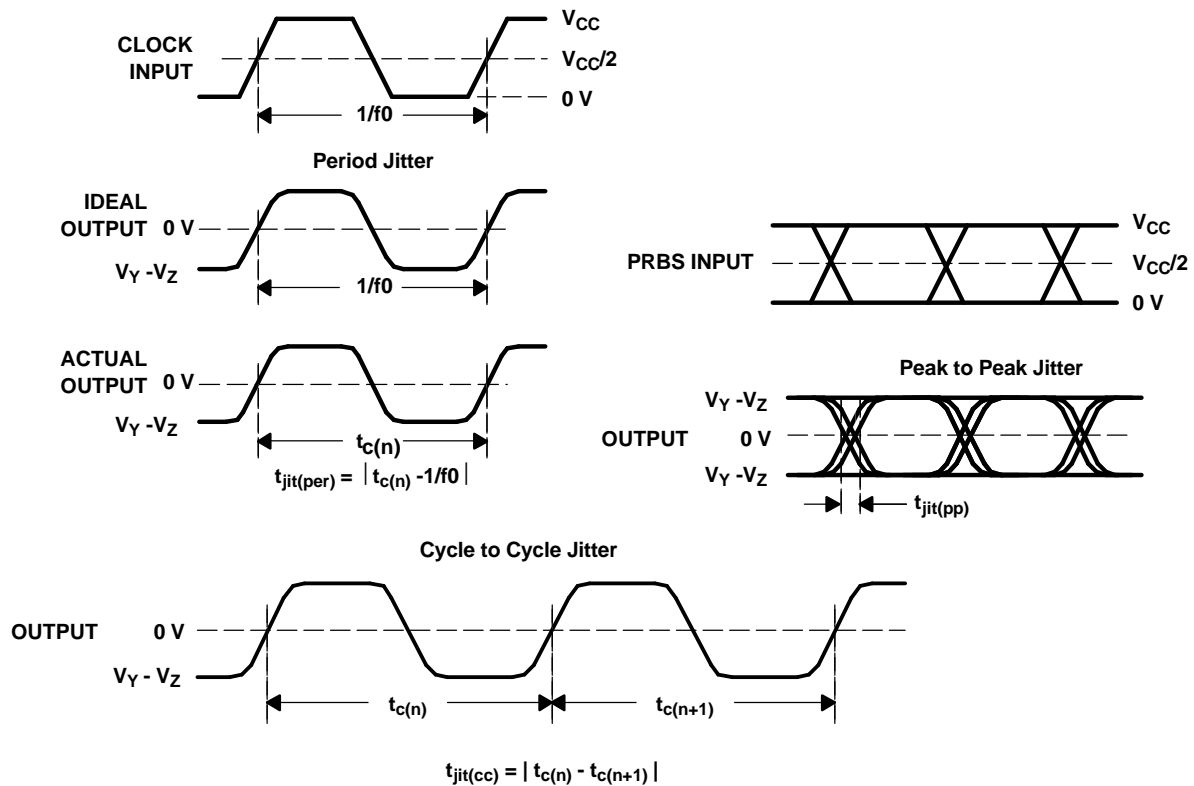

Figure 7. Driver Maximum Steady State Output Voltage



- A. All input pulses are supplied by an Agilent 8304A Stimulus System.
- B. The measurement is made on a TEK TDS6604 running TDSJIT3 application software
- C. Period jitter and cycle-to-cycle jitter are measured using a 100 MHz 50 ±1% duty cycle clock input.
- D. Peak-to-peak jitter is measured using a 200 Mbps 2¹⁵- 1 PRBS input.

Figure 8. Driver Jitter Measurement Waveforms

DEVICE INFORMATION

PIN ASSIGNMENTS

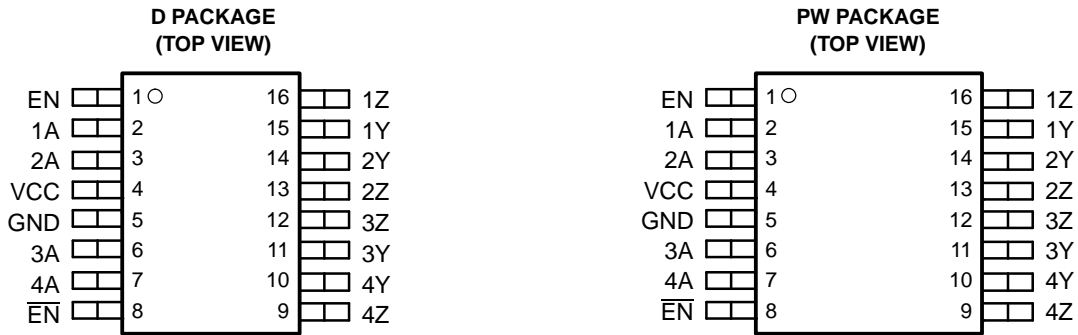

DEVICE FUNCTION TABLE

INPUTS ⁽¹⁾			OUTPUTS ⁽¹⁾	
D	EN	\overline{EN}	Y	Z
L	H	L	L	H
H	H	L	H	L
OPEN	H	L	L	H
X	L or OPEN	X	Z	Z
X	X	H or OPEN	Z	Z

(1) H = high level, L = low level, Z = high impedance, X = Don't Care

EQUIVALENT INPUT AND OUTPUT SCHEMATIC DIAGRAMS

DRIVER INPUT AND POSITIVE DRIVER ENABLE

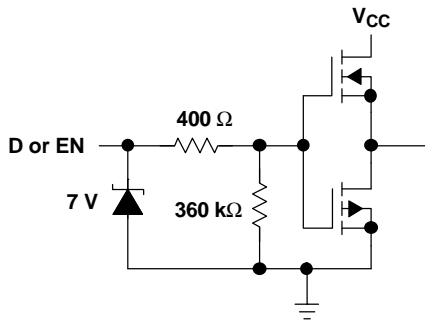

DRIVER OUTPUT

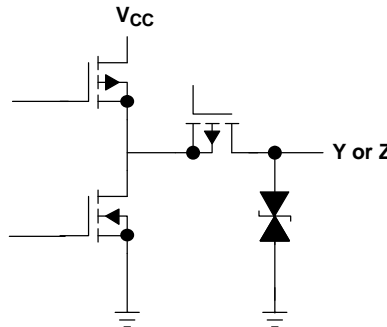

NEGATIVE DRIVER ENABLE

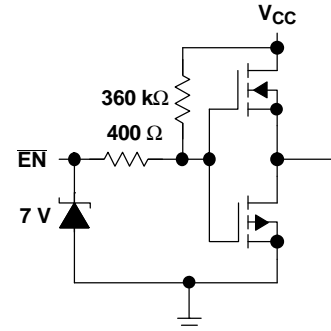

TYPICAL CHARACTERISTICS

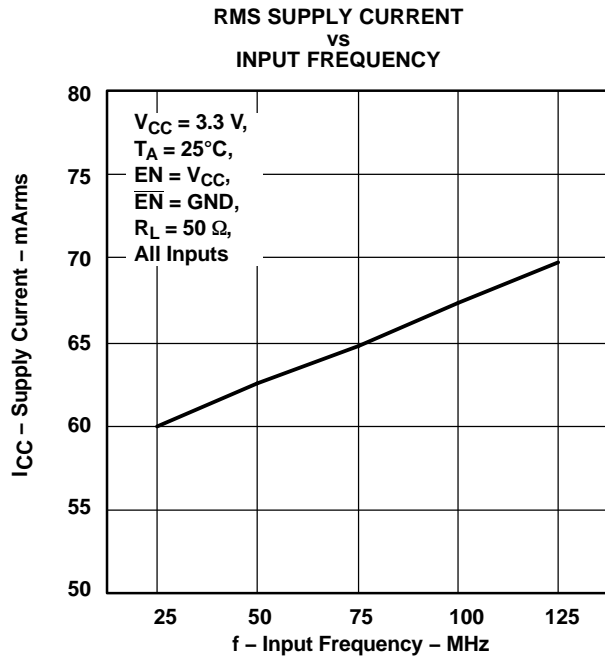

Figure 9.

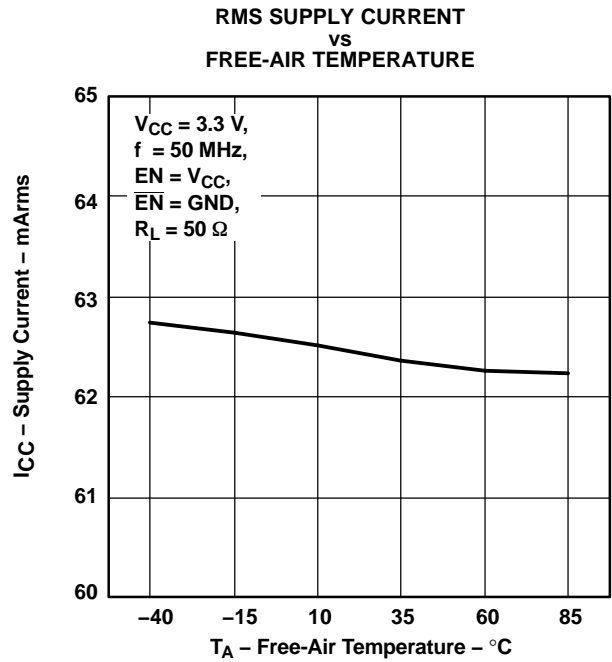

Figure 10.

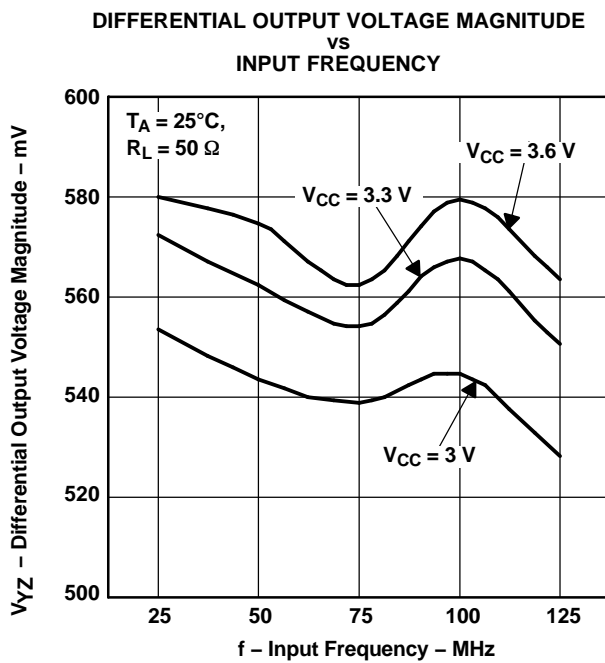

Figure 11.

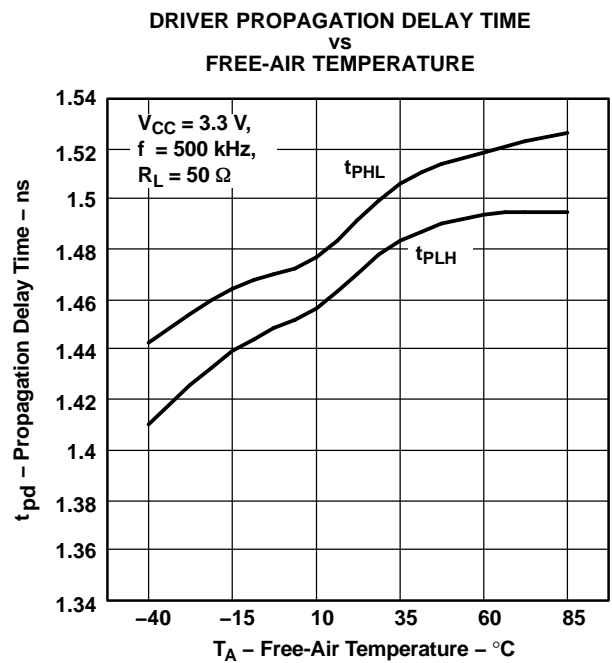

Figure 12.

TYPICAL CHARACTERISTICS (continued)

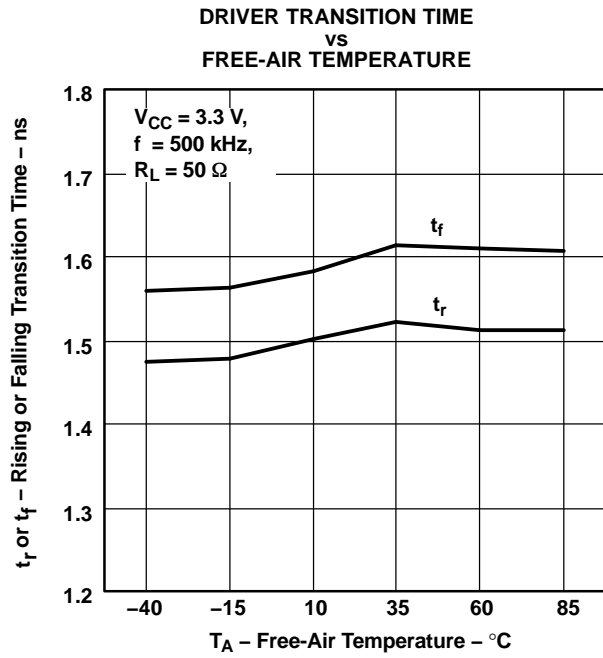

Figure 13.

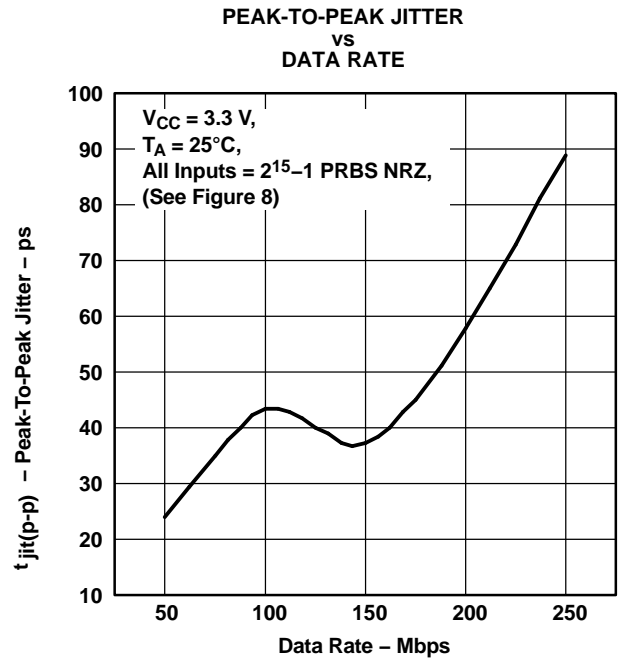

Figure 14.

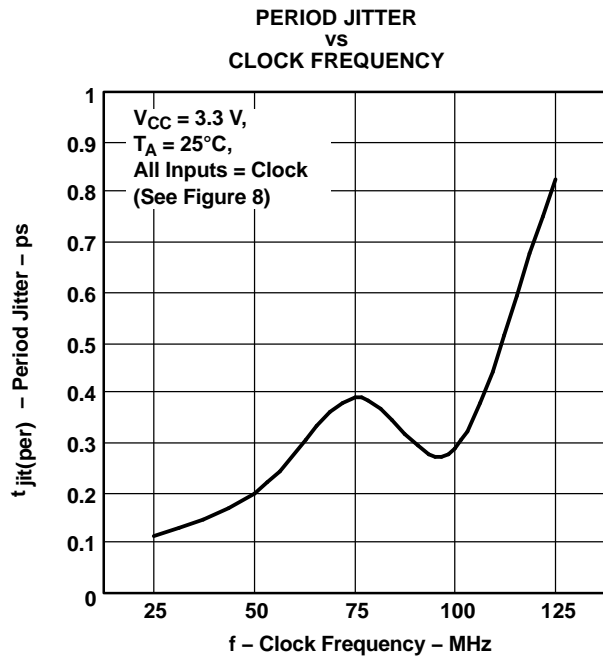

Figure 15.

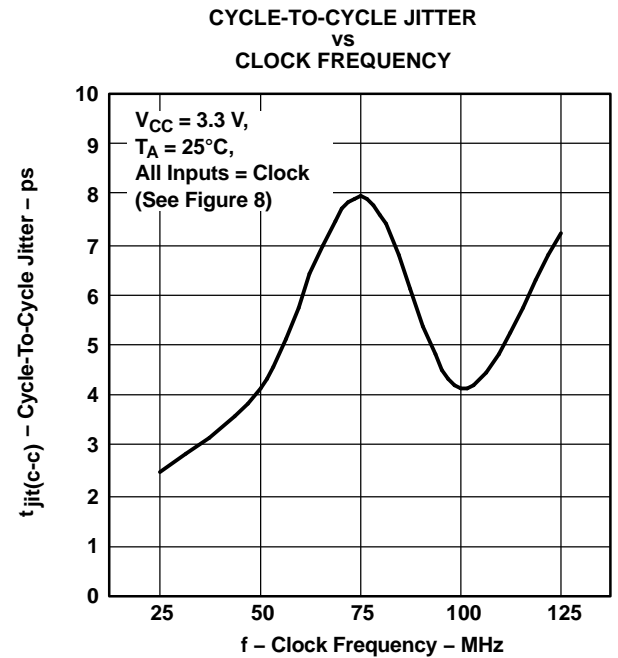

Figure 16.

APPLICATION INFORMATION

Multipoint Configuration

The SN65MLVD047 is designed to allow multipoint communication on a shared bus.

Multipoint is a bus configuration with multiple drivers and receivers present. An example is shown in Figure 17. The figure shows transceivers interfacing to the bus, but a combination of drivers, receivers, and transceivers is also possible. Termination resistors need to be placed on each end of the bus, with the termination resistor value matched to the loaded bus impedance.

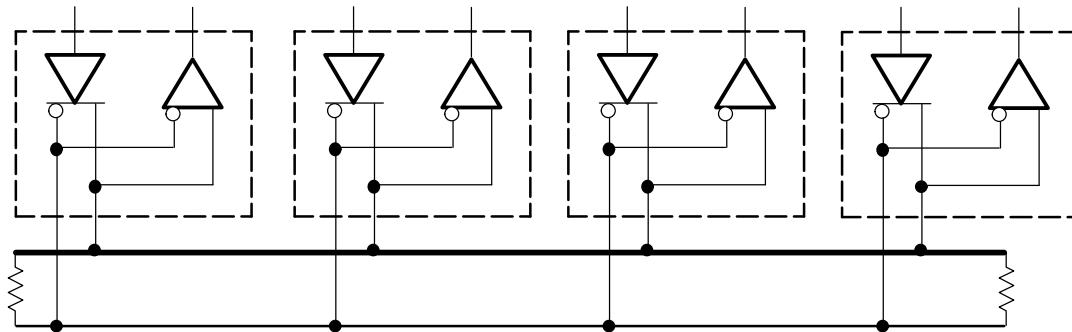

Figure 17. Multipoint Architecture

Multidrop Configuration

Multidrop configuration is similar to multipoint configuration, but only one driver is present on the bus. A multidrop system can be configured with the driver at one end of the bus, or in the middle of the bus. When a driver is located at one end, a single termination resistor is located at the far end, close to the last receiver on the bus. Alternatively, the driver can be located in the middle of the bus, to reduce the maximum flight time. With a centrally located driver, termination resistors are located at each end of the bus. In both cases the termination resistor value should be matched to the loaded bus impedance. Figure 18 shows examples of both cases.

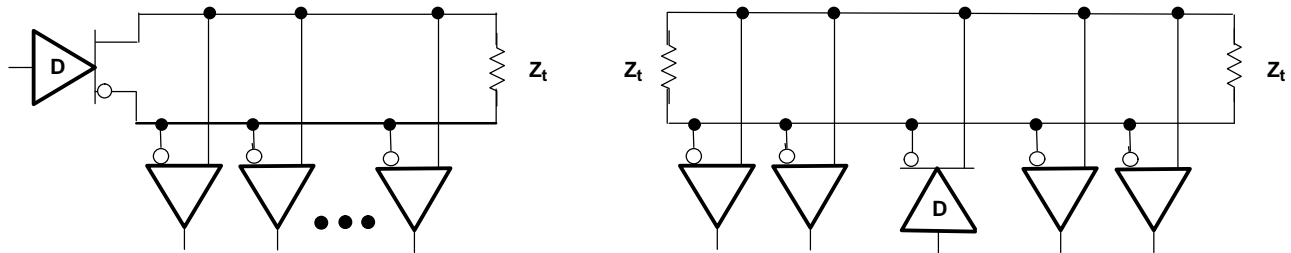

Figure 18. Multidrop Architectures With Different Driver Locations

Unused Channel

The SN65MLVD047 is designed to allow multipoint communication on a standard bus. A 360-k Ω pull-down resistor is built in every LVTTTL input. The unused driver inputs and outputs may be left floating.

Live Insertion/Glitch Free Power Up/Down

During a live insertion event or a power cycle the outputs of the SN65MLVD047 leave the high impedance state and possibly glitch the bus. Specifically when the V_{CC} applied to the device is between 1.3 and 2.0 VDC the output state (high or low) of the device reflects the input level at the corresponding A pin.

APPLICATION INFORMATION (continued)

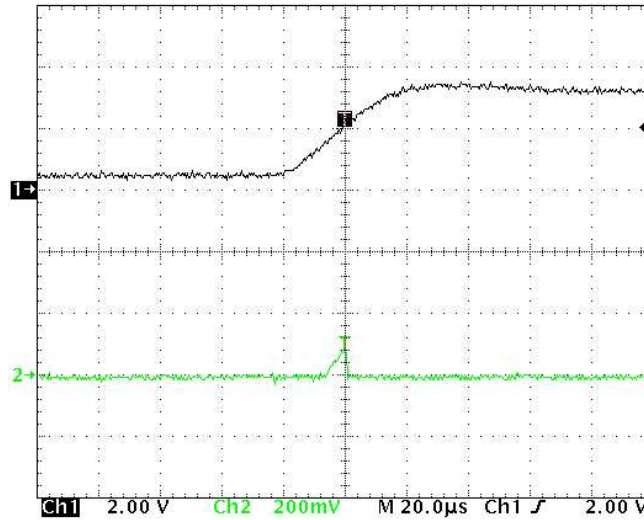

Note: Channel 1: V_{CC} , Channel 2: Differential Bus Voltage

The output state of the part during this voltage range is independent of the EN and \overline{EN} pins.

In order to insure that data is not corrupted during a live insertion event or the power cycling of an individual node on a multipoint bus it is important to isolate the outputs of the device from the bus until the V_{CC} has reached at least 2.0 VDC. At this voltage level the device output state accurately reflects the logic conditions as defined in the Device Function Table.

PACKAGING INFORMATION

Orderable Device	Status (1)	Package Type	Package Drawing	Pins	Package Qty	Eco Plan (2)	Lead/Ball Finish (6)	MSL Peak Temp (3)	Op Temp (°C)	Device Marking (4/5)	Samples
SN65MLVD047D	ACTIVE	SOIC	D	16	40	Green (RoHS & no Sb/Br)	CU NIPDAU	Level-1-260C-UNLIM	-40 to 85	MLVD047	Samples
SN65MLVD047DR	ACTIVE	SOIC	D	16	2500	Green (RoHS & no Sb/Br)	CU NIPDAU	Level-1-260C-UNLIM	-40 to 85	MLVD047	Samples
SN65MLVD047PW	ACTIVE	TSSOP	PW	16	90	Green (RoHS & no Sb/Br)	CU NIPDAU	Level-1-260C-UNLIM	-40 to 85	MLVD047	Samples
SN65MLVD047PWR	ACTIVE	TSSOP	PW	16	2000	Green (RoHS & no Sb/Br)	CU NIPDAU	Level-1-260C-UNLIM	-40 to 85	MLVD047	Samples
SN65MLVD047PWRG4	ACTIVE	TSSOP	PW	16	2000	Green (RoHS & no Sb/Br)	CU NIPDAU	Level-1-260C-UNLIM	-40 to 85	MLVD047	Samples

(1) The marketing status values are defined as follows:

ACTIVE: Product device recommended for new designs.

LIFEBUY: TI has announced that the device will be discontinued, and a lifetime-buy period is in effect.

NRND: Not recommended for new designs. Device is in production to support existing customers, but TI does not recommend using this part in a new design.

PREVIEW: Device has been announced but is not in production. Samples may or may not be available.

OBSOLETE: TI has discontinued the production of the device.

(2) **RoHS:** TI defines "RoHS" to mean semiconductor products that are compliant with the current EU RoHS requirements for all 10 RoHS substances, including the requirement that RoHS substance do not exceed 0.1% by weight in homogeneous materials. Where designed to be soldered at high temperatures, "RoHS" products are suitable for use in specified lead-free processes. TI may reference these types of products as "Pb-Free".

RoHS Exempt: TI defines "RoHS Exempt" to mean products that contain lead but are compliant with EU RoHS pursuant to a specific EU RoHS exemption.

Green: TI defines "Green" to mean the content of Chlorine (Cl) and Bromine (Br) based flame retardants meet JS709B low halogen requirements of <=1000ppm threshold. Antimony trioxide based flame retardants must also meet the <=1000ppm threshold requirement.

(3) MSL, Peak Temp. - The Moisture Sensitivity Level rating according to the JEDEC industry standard classifications, and peak solder temperature.

(4) There may be additional marking, which relates to the logo, the lot trace code information, or the environmental category on the device.

(5) Multiple Device Markings will be inside parentheses. Only one Device Marking contained in parentheses and separated by a "-" will appear on a device. If a line is indented then it is a continuation of the previous line and the two combined represent the entire Device Marking for that device.

(6) Lead/Ball Finish - Orderable Devices may have multiple material finish options. Finish options are separated by a vertical ruled line. Lead/Ball Finish values may wrap to two lines if the finish value exceeds the maximum column width.

Important Information and Disclaimer: The information provided on this page represents TI's knowledge and belief as of the date that it is provided. TI bases its knowledge and belief on information provided by third parties, and makes no representation or warranty as to the accuracy of such information. Efforts are underway to better integrate information from third parties. TI has taken and continues to take reasonable steps to provide representative and accurate information but may not have conducted destructive testing or chemical analysis on incoming materials and chemicals. TI and TI suppliers consider certain information to be proprietary, and thus CAS numbers and other limited information may not be available for release.

In no event shall TI's liability arising out of such information exceed the total purchase price of the TI part(s) at issue in this document sold by TI to Customer on an annual basis.

TAPE AND REEL INFORMATION

QUADRANT ASSIGNMENTS FOR PIN 1 ORIENTATION IN TAPE

*All dimensions are nominal

Device	Package Type	Package Drawing	Pins	SPQ	Reel Diameter (mm)	Reel Width W1 (mm)	A0 (mm)	B0 (mm)	K0 (mm)	P1 (mm)	W (mm)	Pin1 Quadrant
SN65MLVD047DR	SOIC	D	16	2500	330.0	16.4	6.5	10.3	2.1	8.0	16.0	Q1
SN65MLVD047PWR	TSSOP	PW	16	2000	330.0	12.4	6.9	5.6	1.6	8.0	12.0	Q1

TAPE AND REEL BOX DIMENSIONS

*All dimensions are nominal

Device	Package Type	Package Drawing	Pins	SPQ	Length (mm)	Width (mm)	Height (mm)
SN65MLVD047DR	SOIC	D	16	2500	350.0	350.0	43.0
SN65MLVD047PWR	TSSOP	PW	16	2000	350.0	350.0	43.0

D (R-PDSO-G16)

PLASTIC SMALL OUTLINE



- NOTES:
- All linear dimensions are in millimeters.
 - This drawing is subject to change without notice.
 - Publication IPC-7351 is recommended for alternate designs.
 - Laser cutting apertures with trapezoidal walls and also rounding corners will offer better paste release. Customers should contact their board assembly site for stencil design recommendations. Refer to IPC-7525 for other stencil recommendations.
 - Customers should contact their board fabrication site for solder mask tolerances between and around signal pads.



4220204/A 02/2017

NOTES:

1. All linear dimensions are in millimeters. Any dimensions in parenthesis are for reference only. Dimensioning and tolerancing per ASME Y14.5M.
2. This drawing is subject to change without notice.
3. This dimension does not include mold flash, protrusions, or gate burrs. Mold flash, protrusions, or gate burrs shall not exceed 0.15 mm per side.
4. This dimension does not include interlead flash. Interlead flash shall not exceed 0.25 mm per side.
5. Reference JEDEC registration MO-153.

EXAMPLE BOARD LAYOUT

PW0016A

TSSOP - 1.2 mm max height

SMALL OUTLINE PACKAGE



LAND PATTERN EXAMPLE
EXPOSED METAL SHOWN
SCALE: 10X



SOLDER MASK DETAILS

4220204/A 02/2017

NOTES: (continued)

- 6. Publication IPC-7351 may have alternate designs.
- 7. Solder mask tolerances between and around signal pads can vary based on board fabrication site.

EXAMPLE STENCIL DESIGN

PW0016A

TSSOP - 1.2 mm max height

SMALL OUTLINE PACKAGE



SOLDER PASTE EXAMPLE
BASED ON 0.125 mm THICK STENCIL
SCALE: 10X

4220204/A 02/2017

NOTES: (continued)

8. Laser cutting apertures with trapezoidal walls and rounded corners may offer better paste release. IPC-7525 may have alternate design recommendations.
9. Board assembly site may have different recommendations for stencil design.

IMPORTANT NOTICE AND DISCLAIMER

TI PROVIDES TECHNICAL AND RELIABILITY DATA (INCLUDING DATASHEETS), DESIGN RESOURCES (INCLUDING REFERENCE DESIGNS), APPLICATION OR OTHER DESIGN ADVICE, WEB TOOLS, SAFETY INFORMATION, AND OTHER RESOURCES "AS IS" AND WITH ALL FAULTS, AND DISCLAIMS ALL WARRANTIES, EXPRESS AND IMPLIED, INCLUDING WITHOUT LIMITATION ANY IMPLIED WARRANTIES OF MERCHANTABILITY, FITNESS FOR A PARTICULAR PURPOSE OR NON-INFRINGEMENT OF THIRD PARTY INTELLECTUAL PROPERTY RIGHTS.

These resources are intended for skilled developers designing with TI products. You are solely responsible for (1) selecting the appropriate TI products for your application, (2) designing, validating and testing your application, and (3) ensuring your application meets applicable standards, and any other safety, security, or other requirements. These resources are subject to change without notice. TI grants you permission to use these resources only for development of an application that uses the TI products described in the resource. Other reproduction and display of these resources is prohibited. No license is granted to any other TI intellectual property right or to any third party intellectual property right. TI disclaims responsibility for, and you will fully indemnify TI and its representatives against, any claims, damages, costs, losses, and liabilities arising out of your use of these resources.

TI's products are provided subject to TI's Terms of Sale (www.ti.com/legal/termsofsale.html) or other applicable terms available either on ti.com or provided in conjunction with such TI products. TI's provision of these resources does not expand or otherwise alter TI's applicable warranties or warranty disclaimers for TI products.

Mailing Address: Texas Instruments, Post Office Box 655303, Dallas, Texas 75265
Copyright © 2019, Texas Instruments Incorporated

Looking for pricing, stock, or lifecycle information?

Click below to explore more details on WIN SOURCE:

 [View SN65MLVD047PWR on WIN SOURCE](#)

 [Texas Instruments](#) Information

Optimize Your Supply Chain with WIN SOURCE Solutions

-  Global Sourcing Solution
-  Obsolete Management
-  Cost Control Management
-  Shortage Management
-  Alternative Solution
-  Excess Inventory Management