



Is Now Part of



**ON Semiconductor®**

To learn more about ON Semiconductor, please visit our website at  
[www.onsemi.com](http://www.onsemi.com)

Please note: As part of the Fairchild Semiconductor integration, some of the Fairchild orderable part numbers will need to change in order to meet ON Semiconductor's system requirements. Since the ON Semiconductor product management systems do not have the ability to manage part nomenclature that utilizes an underscore (\_), the underscore (\_) in the Fairchild part numbers will be changed to a dash (-). This document may contain device numbers with an underscore (\_). Please check the ON Semiconductor website to verify the updated device numbers. The most current and up-to-date ordering information can be found at [www.onsemi.com](http://www.onsemi.com). Please email any questions regarding the system integration to [Fairchild\\_questions@onsemi.com](mailto:Fairchild_questions@onsemi.com).

ON Semiconductor and the ON Semiconductor logo are trademarks of Semiconductor Components Industries, LLC dba ON Semiconductor or its subsidiaries in the United States and/or other countries. ON Semiconductor owns the rights to a number of patents, trademarks, copyrights, trade secrets, and other intellectual property. A listing of ON Semiconductor's product/patent coverage may be accessed at [www.onsemi.com/site/pdf/Patent-Marking.pdf](http://www.onsemi.com/site/pdf/Patent-Marking.pdf). ON Semiconductor reserves the right to make changes without further notice to any products herein. ON Semiconductor makes no warranty, representation or guarantee regarding the suitability of its products for any particular purpose, nor does ON Semiconductor assume any liability arising out of the application or use of any product or circuit, and specifically disclaims any and all liability, including without limitation special, consequential or incidental damages. Buyer is responsible for its products and applications using ON Semiconductor products, including compliance with all laws, regulations and safety requirements or standards, regardless of any support or applications information provided by ON Semiconductor. "Typical" parameters which may be provided in ON Semiconductor data sheets and/or specifications can and do vary in different applications and actual performance may vary over time. All operating parameters, including "Typicals" must be validated for each customer application by customer's technical experts. ON Semiconductor does not convey any license under its patent rights nor the rights of others. ON Semiconductor products are not designed, intended, or authorized for use as a critical component in life support systems or any FDA Class 3 medical devices or medical devices with a same or similar classification in a foreign jurisdiction or any devices intended for implantation in the human body. Should Buyer purchase or use ON Semiconductor products for any such unintended or unauthorized application, Buyer shall indemnify and hold ON Semiconductor and its officers, employees, subsidiaries, affiliates, and distributors harmless against all claims, costs, damages, and expenses, and reasonable attorney fees arising out of, directly or indirectly, any claim of personal injury or death associated with such unintended or unauthorized use, even if such claim alleges that ON Semiconductor was negligent regarding the design or manufacture of the part. ON Semiconductor is an Equal Opportunity/Affirmative Action Employer. This literature is subject to all applicable copyright laws and is not for resale in any manner.



# FAN2103 — TinyBuck™

## 3 A, 24 V Input, Integrated Synchronous Buck Regulator

### Features

- 3 A Output Current
- Over 95% Efficiency
- Fully Synchronous Operation with Integrated Schottky Diode on Low-side MOSFET Boosts Efficiency
- Programmable Frequency Operation (200 KHz to 600 KHz)
- Power-good Signal
- Accepts Ceramic Capacitors on Output
- External Compensation for Flexible Design
- Wide Input Range: 3 V to 24 V
- Output Voltage Range: 0.8 V to 90%V<sub>IN</sub>
- Input Under-Voltage Lockout
- Programmable Over-Current Limit
- Under-Voltage, Over-Voltage, and Thermal Protections
- 5x6 mm, 25-pin, 3-Pad MLP

### Applications

- Graphics Cards
- Battery-powered Equipment
- Set-top Boxes
- Point-of-load Regulation
- Servers

### Description

The FAN2103 TinyBuck™ is an easy-to-use, cost- and space-efficient, 3 A synchronous buck solution. It enables designers to solve high current requirements in a small area with minimal external components.

External compensation, programmable switching frequency, and current limit features allow for design optimization and flexibility.

The summing current mode modulator uses lossless current sensing for current feedback and over-current, and includes voltage feedforward.

Fairchild's advanced BiCMOS power process, combined with low R<sub>DS(ON)</sub> internal MOSFETs and a thermally efficient MLP package provide the ability to dissipate high power in a small package.

Output over-voltage, under-voltage, and thermal shutdown protections plus power-good, help protect the devices from damage during fault conditions.

### Related Application Notes

- [TinyCalc™ Design Tool](#)
- [AN-6033 — TinyCalc™ Design Tool Guide](#)
- [AN-5067 – PCB Land Pattern Design and Surface Mount Guidelines for MLP Packages](#)

### Ordering Information

Part Number	Operating Temperature Range	Package	Packing Method
FAN2103MPX	-10°C to 85°C	25-Pin Molded Leadless Package (MLP) 5 x 6 mm	Tape and Reel
FAN2103EMPX	-40°C to 85°C		

### Typical Application Diagram

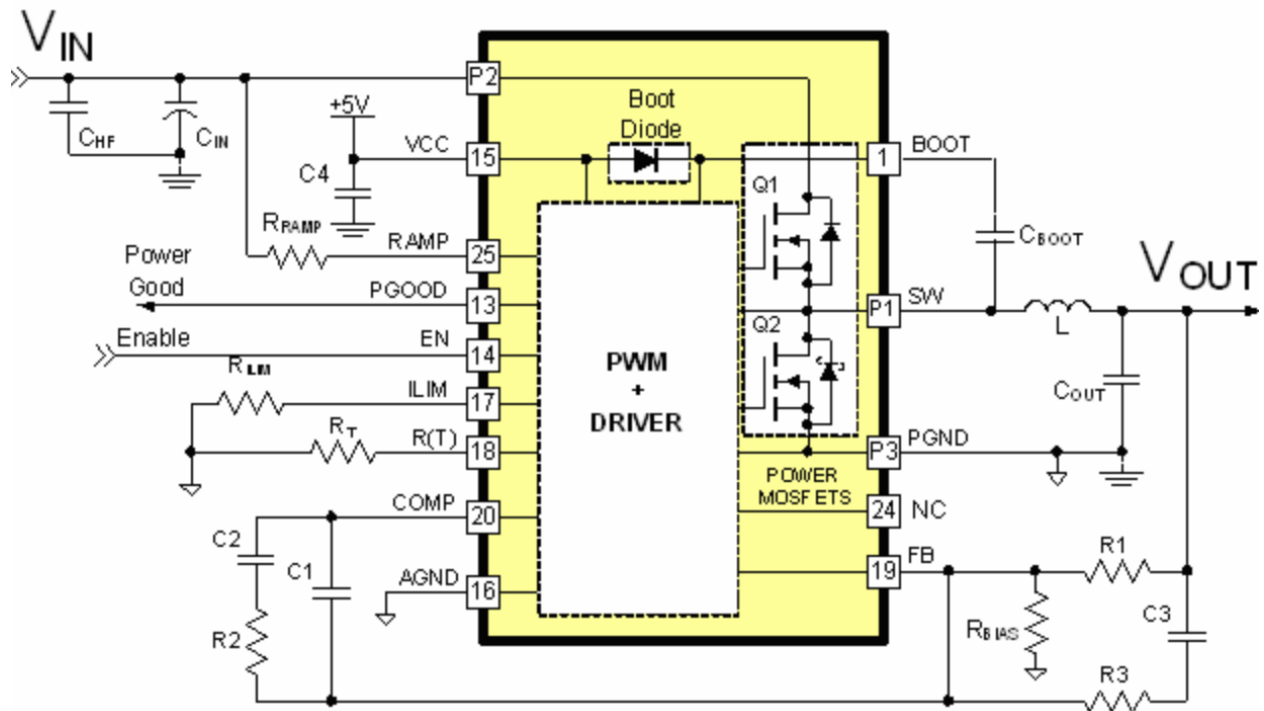

Figure 1. Typical Application

### Block Diagram

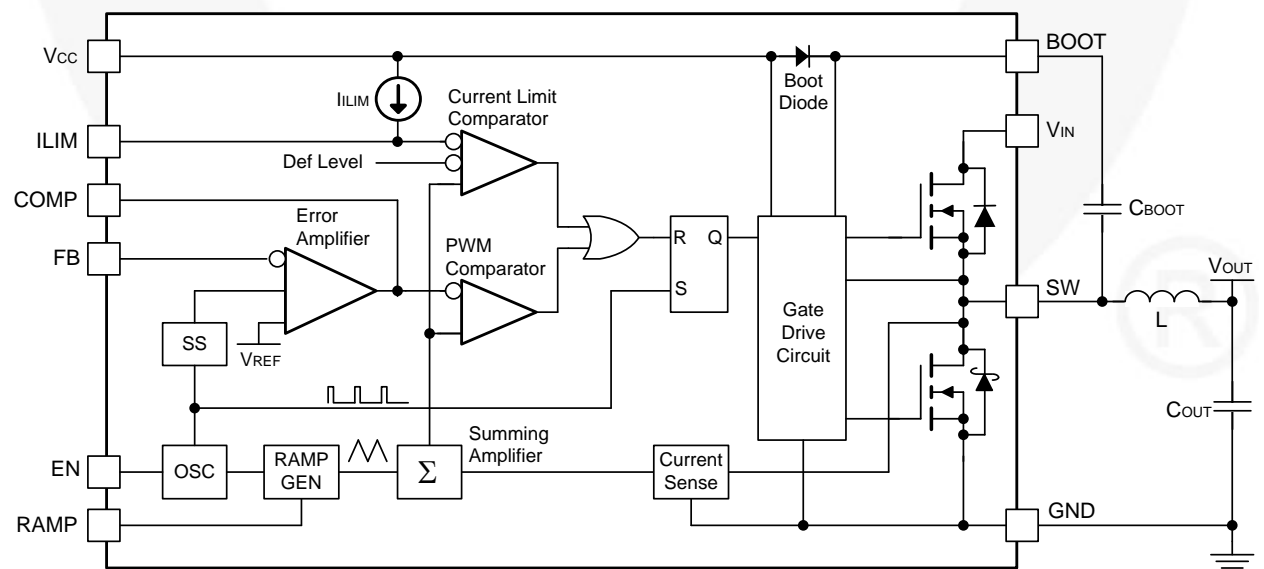

Figure 2. Block Diagram

## Pin Configuration

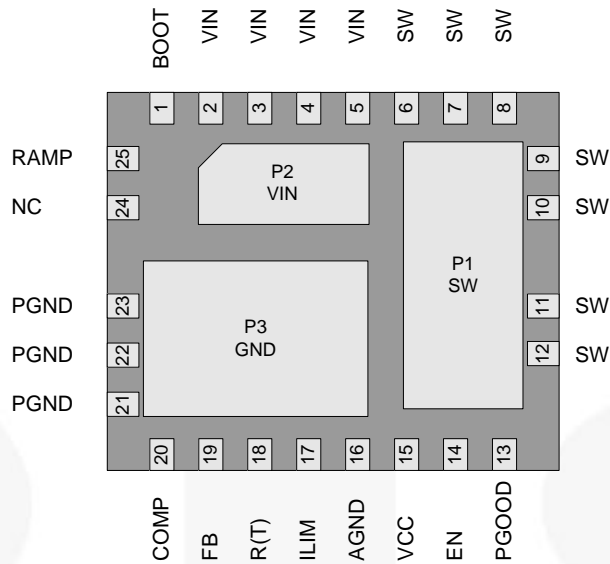

Figure 3. MLP 5 x 6 mm Pin Configuration (Bottom View)

## Pin Definitions

Pin	Name	Description
P1, 6-12	SW	<b>Switching Node.</b>
P2, 2-5	VIN	<b>Power Input Voltage.</b> Connect to the main input power source.
P3, 21-23	PGND	<b>Power Ground.</b> Power return and Q2 source.
1	BOOT	<b>High-side Drive BOOT Voltage.</b> Connect through capacitor ( $C_{BOOT}$ ) to SW. The IC includes an internal synchronous bootstrap diode to recharge the capacitor on this pin to $V_{CC}$ when SW is LOW.
13	PGOOD	<b>Power-Good Flag.</b> An open-drain output that pulls LOW when FB is outside a $\pm 10\%$ range of the reference when EN is HIGH. PGOOD does not assert HIGH until the fault latch is enabled.
14	EN	<b>ENABLE.</b> Enables operation when pulled to logic HIGH or left open. Toggling EN resets the regulator after a latched fault condition. This input has an internal pull-up when the IC is functioning normally. When a latched fault occurs, EN is discharged by a current sink.
15	VCC	<b>Input Bias Supply for IC.</b> The IC's logic and analog circuitry are powered from this pin.
16	AGND	<b>Analog Ground.</b> The signal ground for the IC. All internal control voltages are referred to this pin. Tie this pin to the ground island/plane through the lowest impedance connection.
17	ILIM	<b>Current Limit.</b> A resistor ( $R_{ILIM}$ ) from this pin to AGND can be used to program the current-limit trip threshold lower than the default setting.
18	R(T)	<b>Oscillator Frequency.</b> A resistor ( $R_T$ ) from this pin to AGND sets the PWM switching frequency.
19	FB	<b>Output Voltage Feedback.</b> Connect through a resistor divider to the output voltage.
20	COMP	<b>Compensation.</b> Error amplifier output. Connect the external compensation network between this pin and FB.
24	NC	<b>No Connect.</b> This pin is not used.
25	RAMP	<b>Ramp Amplitude.</b> A resistor ( $R_{RAMP}$ ) connected from this pin to VIN sets the ramp amplitude and provides voltage feedforward functionality.

## Absolute Maximum Ratings

Stresses exceeding the absolute maximum ratings may damage the device. The device may not function or be operable above the recommended operating conditions and stressing the parts to these levels is not recommended. In addition, extended exposure to stresses above the recommended operating conditions may affect device reliability. The absolute maximum ratings are stress ratings only.

Parameter	Conditions	Min.	Max.	Unit
VIN to PGND			28	V
VCC to AGND	AGND = PGND		6	V
BOOT to PGND			35	V
BOOT to SW		-0.3	6.0	V
SW to PGND	Transient (t < 20 ns, f < 600 KHz)	-5	30	V
All other pins		-0.3	V <sub>CC</sub> +0.3	V
ESD	Human Body Model, JEDEC JESD22-A114	2.0		kV
	Charged Device Model, JEDEC JESD22-C101	2.5		

## Recommended Operating Conditions

The Recommended Operating Conditions table defines the conditions for actual device operation. Recommended operating conditions are specified to ensure optimal performance to the datasheet specifications. Fairchild does not recommend exceeding them or designing to absolute maximum ratings.

Symbol	Parameter	Conditions	Min.	Typ.	Max.	Unit
V <sub>CC</sub>	Bias Voltage	VCC to AGND	4.5	5.0	5.5	V
V <sub>IN</sub>	Supply Voltage	VIN to PGND	3		24	V
T <sub>A</sub>	Ambient Temperature	FAN2103M	-10		+85	°C
		FAN2103EM	-40		+85	°C
T <sub>J</sub>	Junction Temperature				+125	°C

## Thermal Information

Symbol	Parameter	Min.	Typ.	Max.	Unit
T <sub>STG</sub>	Storage Temperature	-65		+150	°C
T <sub>L</sub>	Lead Soldering Temperature, 10 Seconds			+300	°C
T <sub>VP</sub>	Vapor Phase, 60 Seconds			+215	°C
T <sub>I</sub>	Infrared, 15 Seconds			+220	°C
θ <sub>JC</sub>	Thermal Resistance: Junction-to-Case	P1 (Q2)	4		°C/W
		P2 (Q1)	7		°C/W
		P3	4		°C/W
θ <sub>J-PCB</sub>	Thermal Resistance: Junction-to-Mounting Surface		35 <sup>(1)</sup>		°C/W
P <sub>D</sub>	Power Dissipation, T <sub>A</sub> = 25°C			2.8 <sup>(1)</sup>	W

### Note:

- Typical thermal resistance when mounted on a four-layer, two-ounce PCB, as shown in Figure 26. Actual results are dependent on mounting method and surface related to the design.

## Electrical Specifications

Recommended operating conditions are the result of using the circuit shown in Figure 1 unless otherwise noted.

Parameter	Conditions	Min.	Typ.	Max.	Unit
<b>Power Supplies</b>					
V <sub>CC</sub> Current	SW = Open, FB = 0.7 V, V <sub>CC</sub> = 5 V, f <sub>SW</sub> = 600 KHz		8	12	mA
	Shutdown: EN = 0, V <sub>CC</sub> = 5 V		7	10	μA
V <sub>CC</sub> UVLO Threshold	Rising V <sub>CC</sub>	4.1	4.3	4.5	V
	Hysteresis		300		mV
<b>Oscillator</b>					
Frequency	R <sub>T</sub> = 50 KΩ	255	300	345	KHz
	R <sub>T</sub> = 24 KΩ	540	600	660	KHz
Minimum On-Time <sup>(2)</sup>			50	65	ns
Ramp Amplitude, pk-pk	16 V <sub>IN</sub> , 1.8 V <sub>OUT</sub> , R <sub>T</sub> = 30 KΩ, R <sub>RAMP</sub> = 200 KΩ		0.53		V
Minimum Off-Time <sup>(2)</sup>			100	150	ns
<b>Reference</b>					
Reference Voltage (V <sub>FB</sub> )	FAN2103M, 25°C	794	800	806	mV
	FAN2103EM, 25°C	795	800	805	mV
Temperature Coefficient	FAN2103M, -10 to +85°C		50		PPM
	FAN2103EM, -40 to +85°C		70		PPM
<b>Error Amplifier</b>					
DC Gain <sup>(2)</sup>	V <sub>CC</sub> = 5 V	80	85		dB
Gain Bandwidth Product <sup>(2)</sup>		12	15		MHz
Output Voltage (V <sub>COMP</sub> )		0.4		3.2	V
Output Current, Sourcing	V <sub>CC</sub> = 5 V, V <sub>COMP</sub> = 2.2 V	1.5	2.2		mA
Output Current, Sinking	V <sub>CC</sub> = 5 V, V <sub>COMP</sub> = 1.2 V	0.8	1.2		mA
FB Bias Current	V <sub>FB</sub> = 0.8 V, 25°C	-850	-650	-450	nA
<b>Protection and Shutdown</b>					
Current Limit	R <sub>LIM</sub> Open	3.8	5.0	7.0	A
I <sub>LIM</sub> Current	25°C, V <sub>CC</sub> = 5 V	9	10	11	μA
Over-Temperature Shutdown	Internal IC Temperature		+160		°C
Over-Temperature Hysteresis		+30		°C	
Over-Voltage Threshold	2 Consecutive Clock Cycles	110	115	120	%V <sub>OUT</sub>
Under-Voltage Shutdown	16 Consecutive Clock Cycles	68	73	78	%V <sub>OUT</sub>
Fault Discharge Threshold	Measured at FB Pin		250		mV
Fault Discharge Hysteresis	Measured at FB Pin (V <sub>FB</sub> ~500 mV)		250		mV
<b>Soft-Start</b>					
V <sub>OUT</sub> to Regulation (T0.8)	Frequency = 600 KHz		5.3		ms
Fault Enable/SSOK (T1.0)			6.7		ms

### Note:

- Specifications guaranteed by design and characterization; not production tested.

**Electrical Specifications** (Continued)

Recommended operating conditions are the result of using the circuit shown in Figure 1 unless otherwise noted.

Parameter	Conditions	Min.	Typ.	Max.	Unit
<b>Control Functions</b>					
EN Threshold, Rising			1.35	2.00	V
EN Hysteresis			250		mV
EN Pull-up Resistance			800		K $\Omega$
EN Discharge Current	Auto-restart Mode		1		$\mu$ A
FB OK Drive Resistance				800	$\Omega$
PGOOD Threshold (Compared to $V_{REF}$ )	$FB < V_{REF}$	-14	-11	-8	% $V_{REF}$
	$FB > V_{REF}$	+7	+10	+13	% $V_{REF}$
PGOOD Output Low	$I_{OUT} \leq 2$ mA			0.4	V

### Typical Characteristics

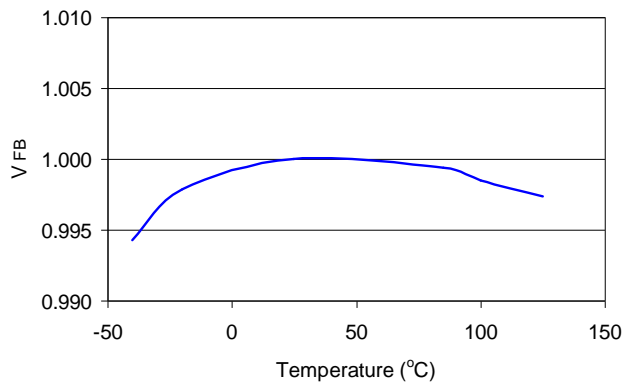

Figure 4. Reference Voltage ( $V_{FB}$ ) vs. Temperature, Normalized

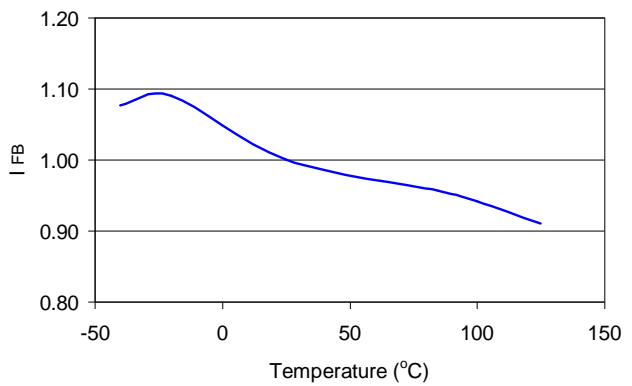

Figure 5. Reference Bias Current ( $I_{FB}$ ) vs. Temperature, Normalized

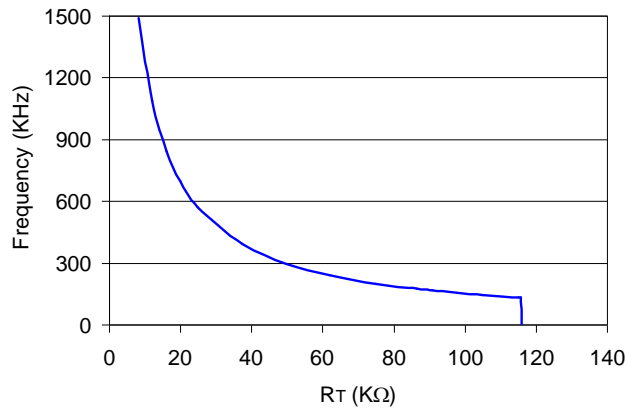

Figure 6. Frequency vs.  $R_T$

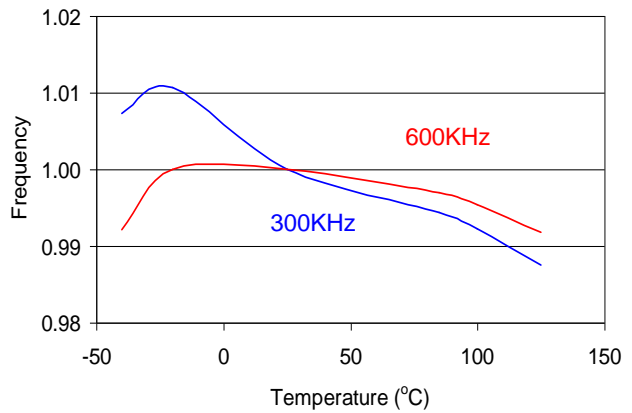

Figure 7. Frequency vs. Temperature, Normalized

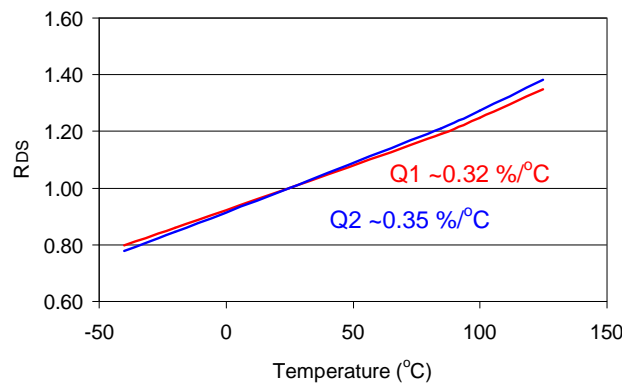

Figure 8.  $R_{DS}$  vs. Temperature, Normalized ( $V_{CC} = V_{GS} = 5 V$ )

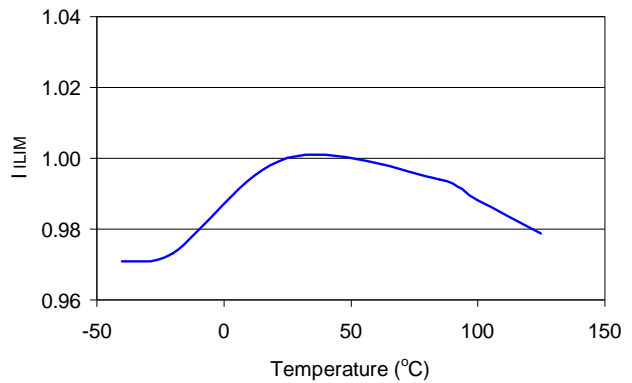

Figure 9.  $I_{LIM}$  Current ( $I_{LIM}$ ) vs. Temperature, Normalized

## Application Circuit

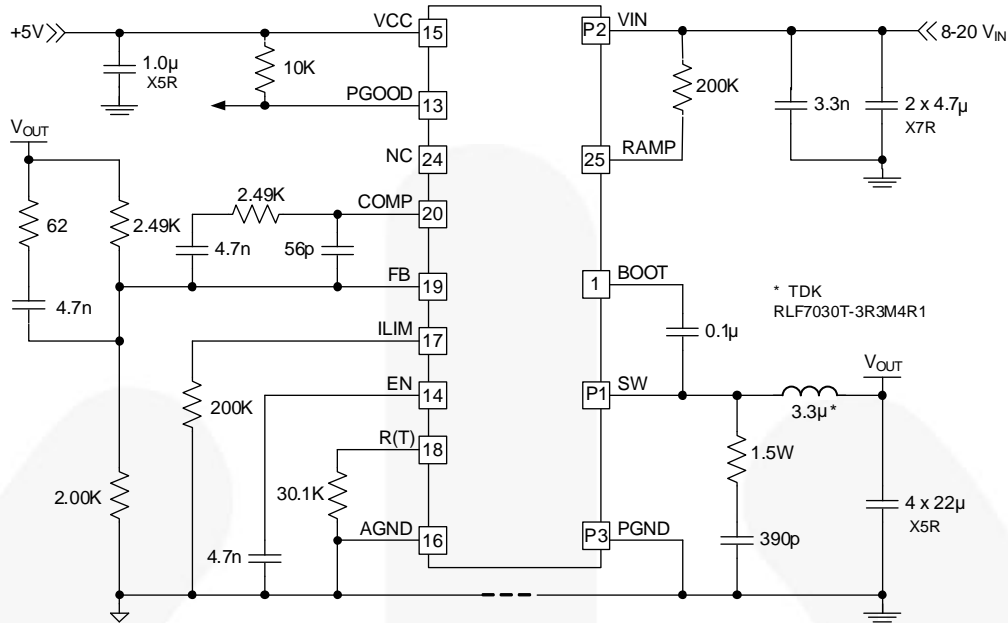

Figure 10. Application Circuit: 1.8 V<sub>OUT</sub>, 500 KHz

## Typical Performance Characteristics

Typical operating characteristics using the circuit shown in Figure 10. V<sub>IN</sub>=16 V, V<sub>CC</sub>=5 V, unless otherwise specified.

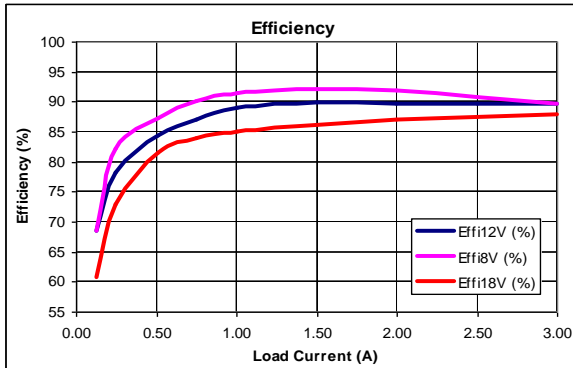

Figure 11. 1.8 V<sub>OUT</sub> Efficiency Over V<sub>IN</sub> vs. Load

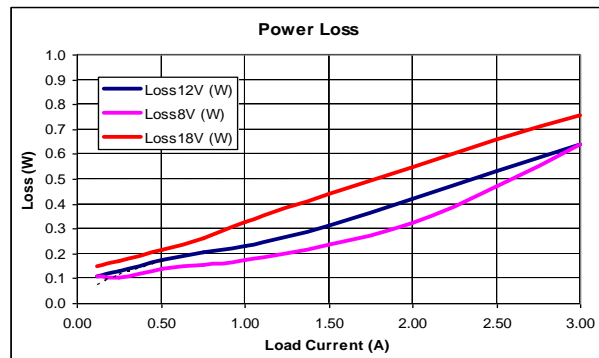

Figure 12. 1.8 V<sub>OUT</sub> Dissipation Over V<sub>IN</sub> vs. Load

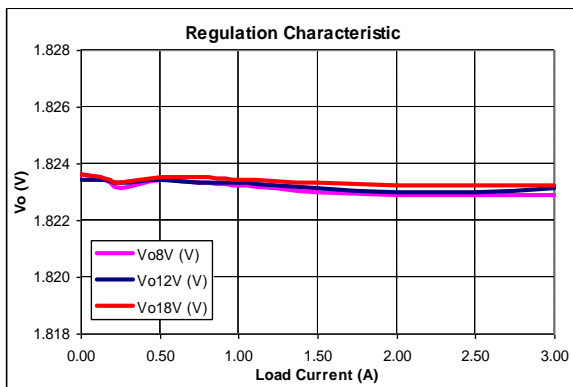

Figure 13. 1.8 V<sub>OUT</sub> Regulation vs. Load

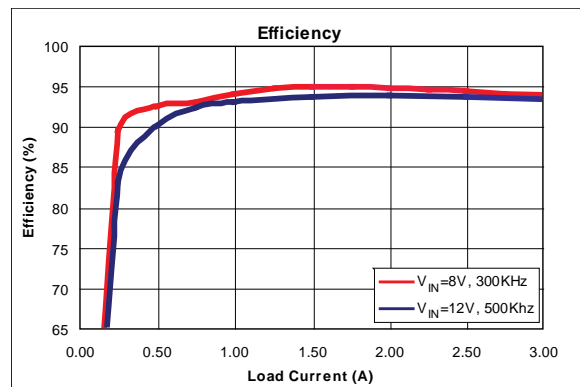
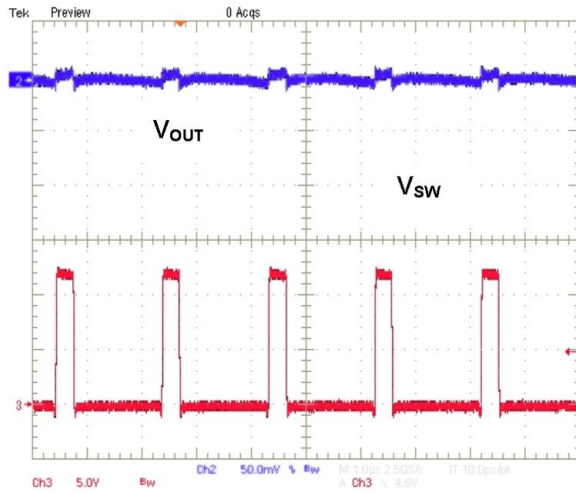

Figure 14. 3.3 V<sub>OUT</sub> Efficiency vs. Load (Circuit Values Changed)

## Typical Performance Characteristics (Continued)

Typical operating characteristics using the circuit shown in Figure 10.  $V_{IN}=12\text{ V}$ ,  $V_{CC}=5\text{ V}$ , unless otherwise specified.



**Figure 15. SW and  $V_{OUT}$  Ripple, 3 A Load**

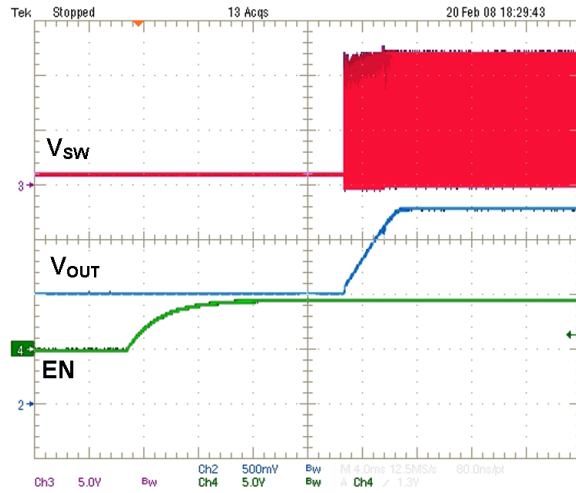

**Figure 16. Startup with 1 V Pre-Bias on  $V_{OUT}$**

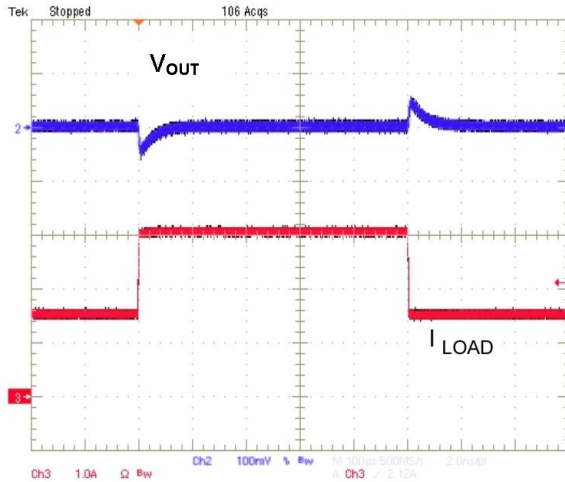

**Figure 17. Transient Response, 1.5-3 A Load (Circuit Values Changed)**

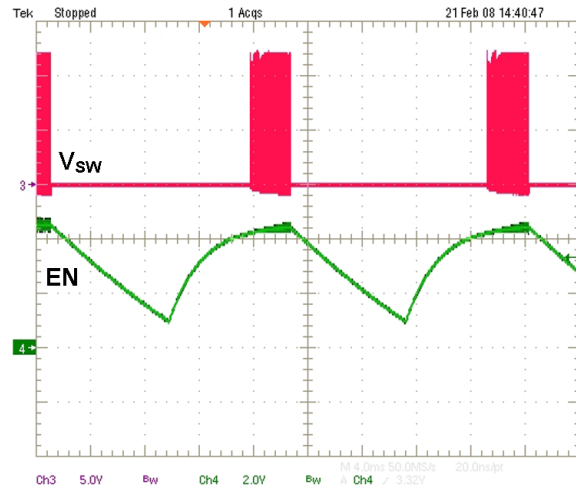

**Figure 18. Re-start on Fault**

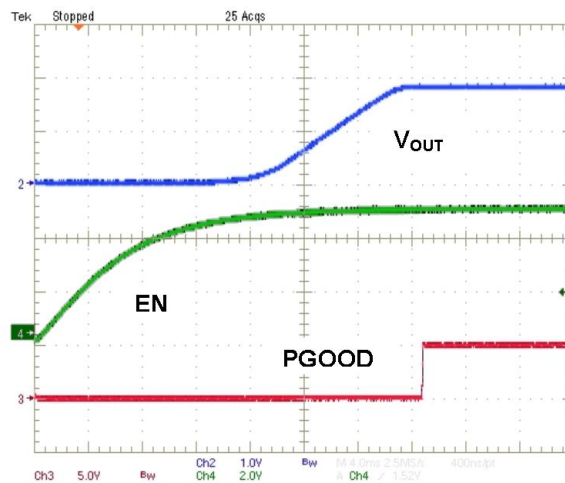

**Figure 19. Startup, 3 A Load**

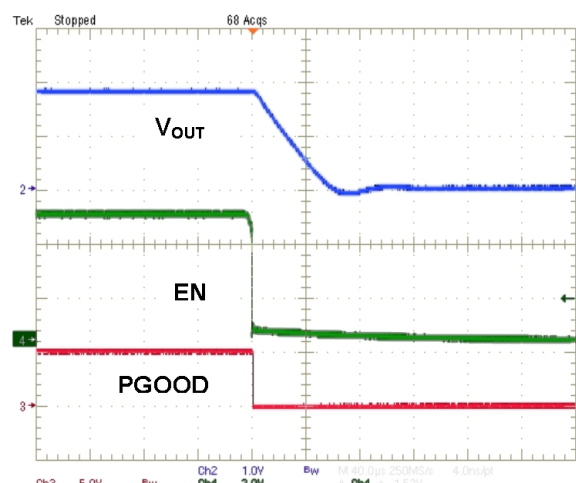

**Figure 20. Shutdown, 3 A Load**

## Circuit Description

### Initialization

Once  $V_{CC}$  exceeds the UVLO threshold and EN is HIGH, the IC checks for an open or shorted FB pin before releasing the internal soft-start ramp (SS).

If R1 is open (as shown in Figure 1), the error amplifier output (COMP) is forced LOW and no pulses are generated. After the SS ramp times out (T1.0), an under-voltage latched fault occurs.

If the parallel combination of R1 and  $R_{BIAS}$  is  $\leq 1K\Omega$ , the internal SS ramp is not released and the regulator does not start.

### Soft-Start

Once internal SS ramp has charged to 0.8 V (T0.8), the output voltage is in regulation. Until SS ramp reaches 1.0 V (T1.0), the "Fault Latch" is inhibited.

To avoid skipping the soft-start cycle, it is necessary to apply  $V_{IN}$  before  $V_{CC}$  reaches its UVLO threshold.

Soft-start time is a function of oscillator frequency.

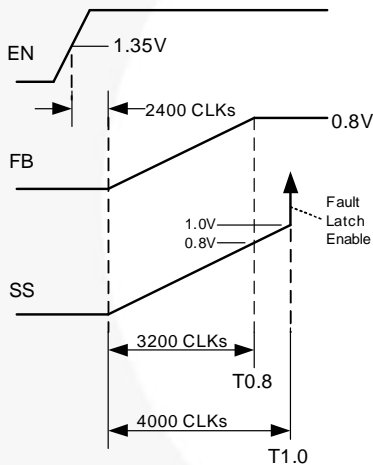

**Figure 21. Soft-Start Timing Diagram**

The regulator does not allow the low-side MOSFET to operate in full synchronous rectification mode until internal SS ramp reaches 95% of  $V_{REF}$  (~0.76 V). This helps the regulator start against pre-biased outputs (as shown in Figure 16) and ensures that inductor current does not "ratchet" up during the soft-start cycle.

$V_{CC}$  UVLO or toggling the EN pin discharges the SS and resets the IC.

### Bias Supply

The FAN2103 requires a 5 V supply rail to bias the IC and provide gate-drive energy and controller power. Connect a  $\geq 1.0 \mu\text{f}$  X5R or X7R decoupling capacitor between  $V_{CC}$  and PGND. Whenever the EN pin is pulled up to  $V_{CC}$ , the 5 V supply connected to  $V_{CC}$  should be turned ON after  $V_{IN}$  comes up. If the power supply is turned ON using EN pin with an external control after  $V_{CC}$  and  $V_{IN}$  come up, the  $V_{CC}$  and  $V_{IN}$  power sequencing is not relevant.

Since  $V_{CC}$  is used to drive the internal MOSFET gates, supply current is frequency and voltage dependent. Approximate  $V_{CC}$  current ( $I_{CC}$ ) can be calculated using:

$$I_{CC(\text{mA})} = 4.58 + \left[ \left( \frac{V_{CC} - 5}{227} + 0.013 \right) \cdot (f - 128) \right] \quad (1)$$

where frequency (f) is expressed in KHz.

### Setting the Output Voltage

The output voltage of the regulator can be set from 0.8 V to ~80% of  $V_{IN}$  by an external resistor divider (R1 and  $R_{BIAS}$  in Figure 1).

The internal reference is 0.8 V with 650 nA, sourced from the FB pin to ensure that if the pin is open, the regulator does not start.

The external resistor divider is calculated using:

$$\frac{0.8\text{V}}{R_{BIAS}} = \frac{V_{OUT} - 0.8\text{V}}{R1} + 650\text{nA} \quad (2)$$

Connect  $R_{BIAS}$  between FB and AGND.

### Setting the Frequency

Oscillator frequency is determined by an external resistor,  $R_T$ , connected between the R(T) pin and AGND:

$$f(\text{KHz}) = \frac{10^6}{(65 \cdot R_T) + 135} \quad (3)$$

where  $R_T$  is expressed in  $K\Omega$ .

$$R_{T(K\Omega)} = \frac{(10^6 / f) - 135}{65} \quad (4)$$

where frequency (f) is expressed in KHz.

The regulator does not start if  $R_T$  is left open.

## Calculating the Inductor Value

Typically the inductor is set for a ripple current ( $\Delta I_L$ ) of 10% to 35% of the maximum DC load. Regulators requiring fast transient response use a value on the high side of this range, while regulators that require very low output ripple and/or use high-ESR capacitors restrict allowable ripple current:

$$\Delta I_L = \frac{V_{OUT} \cdot (1 - D)}{L \cdot f} \quad (5)$$

where  $f$  is the oscillator frequency and:

$$L = \frac{V_{OUT} \cdot (1 - D)}{\Delta I_L \cdot f} \quad (6)$$

## Setting the Ramp Resistor Value

The internal ramp voltage excursion ( $\Delta V_{RAMP}$ ) during  $t_{ON}$  should be set to 0.6 V.  $R_{RAMP}$  is approximately:

$$R_{RAMP}(K\Omega) = \frac{(V_{IN} - 1.8) \cdot V_{OUT}}{18 \times 10^{-6} \cdot V_{IN} \cdot f} - 2 \quad (7)$$

where frequency ( $f$ ) is expressed in KHz.

## Setting the Current Limit

The current limit system involves two comparators. The MAX  $I_{LIMIT}$  comparator is used with a  $V_{ILIM}$  fixed-voltage reference and represents the maximum current limit allowable. This reference voltage is temperature compensated to reflect the  $R_{DS(ON)}$  variation of the low-side MOSFET. The ADJUST  $I_{LIMIT}$  comparator is used where the current limit needs to be set lower than the  $V_{ILIM}$  fixed reference. The 10  $\mu A$  current source does not track the  $R_{DS(ON)}$  changes over temperature, so change is added into the equations for calculating the ADJUST  $I_{LIMIT}$  comparator reference voltage, as is shown below. Figure 22 shows a simplified schematic of the over-current system.

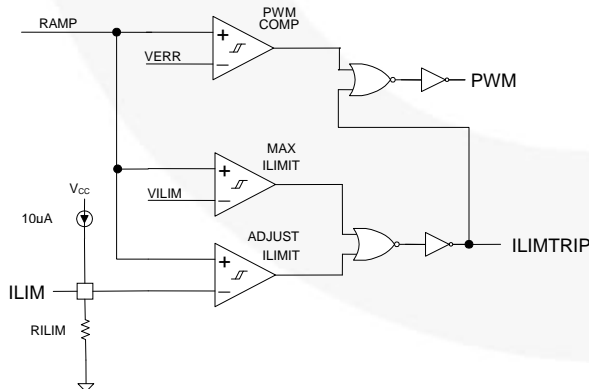

**Figure 22. Current-Limit System Schematic**

Since the  $I_{LIM}$  voltage is set by a 10  $\mu A$  current source into the  $R_{ILIM}$  resistor, the basic equation for setting the reference voltage is:

$$V_{RILIM} = 10\mu A \cdot R_{ILIM} \quad (8)$$

To calculate  $R_{ILIM}$ :

$$R_{ILIM} = V_{RILIM} / 10\mu A \quad (9)$$

The voltage  $V_{RILIM}$  is made up of two components,  $V_{BOT}$  (which relates to the current through the low-side MOSFET) and  $V_{RMPEAK}$  (which relates to the peak current through the inductor). Combining those two voltage terms results in:

$$R_{ILIM} = (V_{BOT} + V_{RMPEAK}) / 10\mu A \quad (10)$$

$$R_{ILIM} = \{0.96 + (I_{LOAD} \cdot R_{DS(ON)} \cdot K_T \cdot 8)\} + \{D \cdot (V_{IN} - 1.8) / (f_{SW} \cdot 0.03 \cdot 10^{-3} \cdot R_{RAMP})\} / 10\mu A \quad (11)$$

where:

$$V_{BOT} = 0.96 + (I_{LOAD} \cdot R_{DS(ON)} \cdot K_T \cdot 8);$$

$$V_{RMPEAK} = D \cdot (V_{IN} - 1.8) / (f_{SW} \cdot 0.03 \cdot 10^{-3} \cdot R_{RAMP});$$

$I_{LOAD}$  = the desired maximum load current;

$R_{DS(ON)}$  = the nominal  $R_{DS(ON)}$  of the low-side MOSFET;

$K_T$  = the normalized temperature coefficient for the low-side MOSFET (on datasheet graph);

$D = V_{OUT} / V_{IN}$  duty cycle;

$f_{SW}$  = Clock frequency in kHz; and

$R_{RAMP}$  = chosen ramp resistor value in  $k\Omega$ .

After 16 consecutive, pulse-by-pulse, current-limit cycles, the fault latch is set and the regulator shuts down. Cycling  $V_{CC}$  or EN restores operation after a normal soft-start cycle (refer to the *Auto-Restart section*).

The over-current protection fault latch is active during the soft-start cycle. Use 1% resistor for  $R_{ILIM}$ .

## Loop Compensation

The loop is compensated using a feedback network around the error amplifier. Figure 23 shows a complete Type-3 compensation network. Type-2 compensation eliminates  $R3$  and  $C3$ .

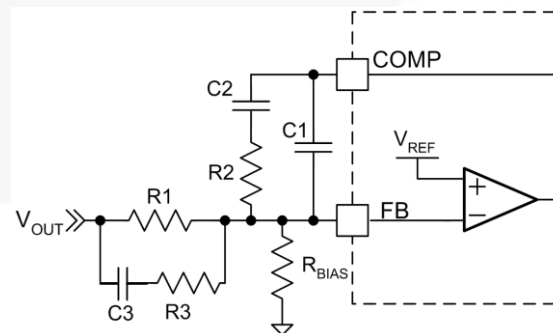

**Figure 23. Compensation Network**

Because the FAN2103 employs summing current-mode architecture, Type-2 compensation can be used for many applications. For applications that require wide loop bandwidth and/or use very low-ESR output capacitors, Type-3 compensation may be required.

$R_{RAMP}$  provides feedforward compensation for changes in  $V_{IN}$ . With a fixed  $R_{RAMP}$  value, the modulator gain increases as  $V_{IN}$  is reduced, which could make it difficult to compensate the loop. For designs with low input voltages (3 V to 6.5 V), it is recommended that a separate  $R_{RAMP}$  and the compensation component values are used as compared to designs with  $V_{IN}$  between 6.5 V and 24 V.

### Protection

The converter output is monitored and protected against extreme overload, short-circuit, over-voltage, and under-voltage conditions.

An internal "Fault Latch" is set for any fault intended to shut down the IC. When the fault latch is set, the IC discharges  $V_{OUT}$  by enhancing the low-side MOSFET until  $FB < 0.25$  V. The MOSFET is not turned on again unless  $FB > 0.5$  V. This behavior discharges the output without causing undershoot (negative output voltage).

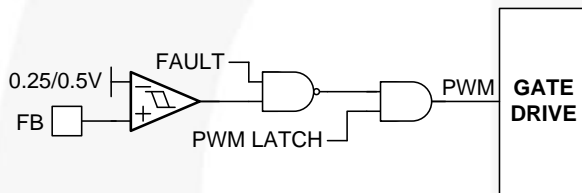

Figure 24. Latched Fault Response

### Under-Voltage Shutdown

If FB remains below the under-voltage threshold for 16 consecutive clock cycles, the fault latch is set and the converter shuts down. This fault is prevented from setting the fault latch during soft-start.

### Over-Voltage Protection / Shutdown

If FB exceeds  $115\% \cdot V_{REF}$  for two consecutive clock cycles, the fault latch is set and shutdown occurs.

A shorted high-side MOSFET condition is detected when SW voltage exceeds  $-0.7$  V while the low-side MOSFET is fully enhanced. The fault latch is set immediately upon detection.

The two fault protection circuits above are active all the time, including during soft-start.

### Auto-Restart

After a fault, EN is discharged with  $1 \mu A$  to a 1.1 V threshold before the 800 K $\Omega$  pull-up is restored. A new soft-start cycle begins when EN charges above 1.35 V.

Depending on the external circuit, the FAN2103 can be provisioned to remain latched-off or automatically restart after a fault.

Table 1. Fault / Restart Provisioning

EN pin	Controller / Restart State
Pull to GND	OFF (disabled)
$V_{CC}$	No restart – latched OFF (after $V_{CC}$ comes up)
Open	Immediate restart after fault
Cap to GND	New soft-start cycle after: $t_{DELAY} (ms) = 3.9 \cdot C(nf)$

With EN left open, restart is immediate.

If auto-restart is not desired, tie the EN pin to the  $V_{CC}$  pin or pull it high after  $V_{CC}$  comes up with a logic gate to keep the  $1 \mu A$  current sink from discharging EN to 1.1 V.

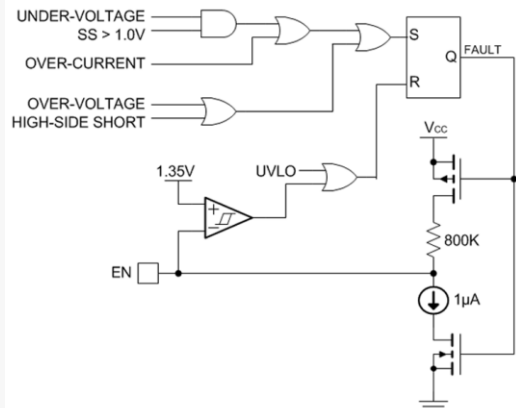

Figure 25. Fault Latch with Delayed Auto-Restart

### Over-Temperature Protection

FAN2103 incorporates an over-temperature protection circuit that sets the fault latch when a die temperature of about  $160^{\circ}C$  is reached. The IC is allowed to restart when the die temperature falls below  $130^{\circ}C$ .

### Power Good (PGOOD) Signal

PGOOD is an open-drain output that asserts LOW when  $V_{OUT}$  is out of regulation, as measured at the FB pin (thresholds are specified in the Electrical Specifications section). PGOOD does not assert HIGH until the fault latch is enabled (T1.0).

### PCB Layout

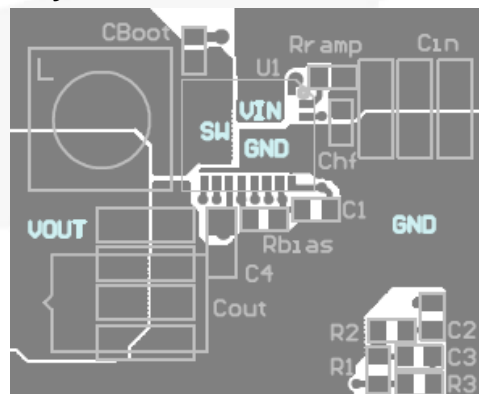
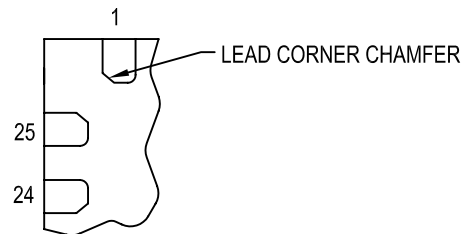
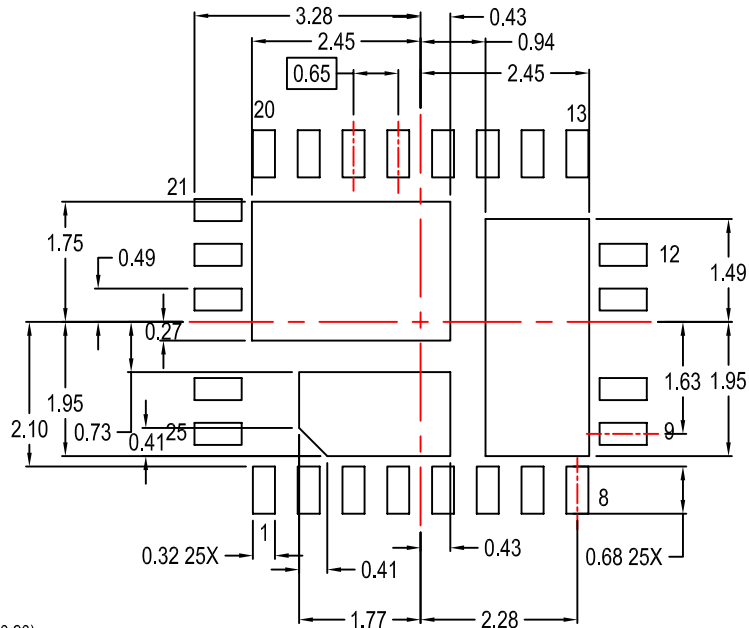
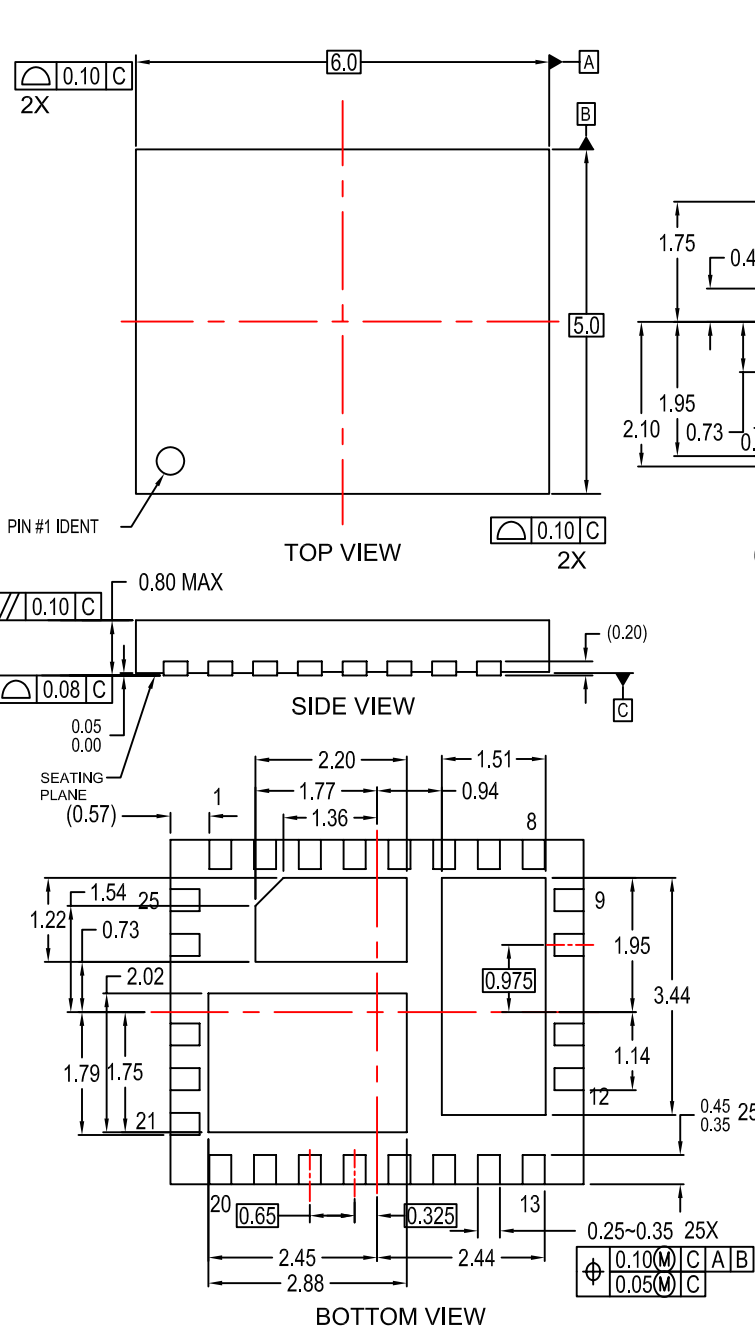

Figure 26. Recommended PCB Layout

REVISIONS			
LTR	DESCRIPTION	DATE	BY/SITE
1	RELEASE TO DOCUMENT CONTROL	12-Jul-2007	J.Chan/FSPM
2	ADDED DIMENSIONS TO BOTTOM VIEW AND LANDPATTERN RECOMMENDATION	7-SEPT-2007	H.ALLEN/FSME
3	CHAMFERED LANDPATTERN PAD 1	17-JUN-2009	H.ALLEN/FSME



- NOTES: UNLESS OTHERWISE SPECIFIED**
- A) DIMENSIONS ARE IN MILLIMETERS.
  - B) DIMENSIONS AND TOLERANCES PER ASME Y14.5M, 1994
  - C) DIMENSIONS DO NOT INCLUDE MOLD FLASH OR BURRS.
  - D) DESIGN BASED ON JEDEC MO-220 VARIATION WJHC
  - E) TERMINALS ARE SYMMETRICAL AROUND THE X & Y AXIS EXCEPT WHERE DEPOPULATED.
  - F) DRAWING FILENAME: MKT-MLP25AREV3

APPROVALS		DATE	Bayan Lepas, FIZ, 11900, Penang, Malaysia.
DRAWN	H.ALLEN	7-SEPT-07	
DFTG. CHK.	S.MARTIN	7-SEPT-07	
ENGR. CHK.			
INCH [MM]			SCALE: N/A SIZE: N/A DRAWING NUMBER: MKT-MLP25A REV: 3
			DO NOT SCALE DRAWING SHEET 1 of 1

25LD, MLP, QUAD, NON-JEDEC, 6x5MM TRIPLE DAP

ON Semiconductor and  are trademarks of Semiconductor Components Industries, LLC dba ON Semiconductor or its subsidiaries in the United States and/or other countries. ON Semiconductor owns the rights to a number of patents, trademarks, copyrights, trade secrets, and other intellectual property. A listing of ON Semiconductor's product/patent coverage may be accessed at [www.onsemi.com/site/pdf/Patent-Marking.pdf](http://www.onsemi.com/site/pdf/Patent-Marking.pdf). ON Semiconductor reserves the right to make changes without further notice to any products herein. ON Semiconductor makes no warranty, representation or guarantee regarding the suitability of its products for any particular purpose, nor does ON Semiconductor assume any liability arising out of the application or use of any product or circuit, and specifically disclaims any and all liability, including without limitation special, consequential or incidental damages. Buyer is responsible for its products and applications using ON Semiconductor products, including compliance with all laws, regulations and safety requirements or standards, regardless of any support or applications information provided by ON Semiconductor. "Typical" parameters which may be provided in ON Semiconductor data sheets and/or specifications can and do vary in different applications and actual performance may vary over time. All operating parameters, including "Typicals" must be validated for each customer application by customer's technical experts. ON Semiconductor does not convey any license under its patent rights nor the rights of others. ON Semiconductor products are not designed, intended, or authorized for use as a critical component in life support systems or any FDA Class 3 medical devices or medical devices with a same or similar classification in a foreign jurisdiction or any devices intended for implantation in the human body. Should Buyer purchase or use ON Semiconductor products for any such unintended or unauthorized application, Buyer shall indemnify and hold ON Semiconductor and its officers, employees, subsidiaries, affiliates, and distributors harmless against all claims, costs, damages, and expenses, and reasonable attorney fees arising out of, directly or indirectly, any claim of personal injury or death associated with such unintended or unauthorized use, even if such claim alleges that ON Semiconductor was negligent regarding the design or manufacture of the part. ON Semiconductor is an Equal Opportunity/Affirmative Action Employer. This literature is subject to all applicable copyright laws and is not for resale in any manner.

## PUBLICATION ORDERING INFORMATION

### LITERATURE FULFILLMENT:

Literature Distribution Center for ON Semiconductor  
19521 E. 32nd Pkwy, Aurora, Colorado 80011 USA  
**Phone:** 303-675-2175 or 800-344-3860 Toll Free USA/Canada  
**Fax:** 303-675-2176 or 800-344-3867 Toll Free USA/Canada  
**Email:** [orderlit@onsemi.com](mailto:orderlit@onsemi.com)

**N. American Technical Support:** 800-282-9855 Toll Free  
USA/Canada  
**Europe, Middle East and Africa Technical Support:**  
Phone: 421 33 790 2910  
**Japan Customer Focus Center**  
Phone: 81-3-5817-1050

**ON Semiconductor Website:** [www.onsemi.com](http://www.onsemi.com)  
**Order Literature:** <http://www.onsemi.com/orderlit>  
For additional information, please contact your local  
Sales Representative

## Looking for pricing, stock, or lifecycle information?

Click below to explore more details on WIN SOURCE:

- ⊖ [View FAN2103MPX on WIN SOURCE](#)
- ⊖ [Fairchild/ON Semiconductor Information](#)

## Optimize Your Supply Chain with WIN SOURCE Solutions

- ✓ Global Sourcing Solution
- ✓ Obsolete Management
- ✓ Cost Control Management
- ✓ Shortage Management
- ✓ Alternative Solution
- ✓ Excess Inventory Management