



Is Now Part of



ON Semiconductor®

To learn more about ON Semiconductor, please visit our website at
www.onsemi.com

Please note: As part of the Fairchild Semiconductor integration, some of the Fairchild orderable part numbers will need to change in order to meet ON Semiconductor's system requirements. Since the ON Semiconductor product management systems do not have the ability to manage part nomenclature that utilizes an underscore (_), the underscore (_) in the Fairchild part numbers will be changed to a dash (-). This document may contain device numbers with an underscore (_). Please check the ON Semiconductor website to verify the updated device numbers. The most current and up-to-date ordering information can be found at www.onsemi.com. Please email any questions regarding the system integration to Fairchild_questions@onsemi.com.

ON Semiconductor and the ON Semiconductor logo are trademarks of Semiconductor Components Industries, LLC dba ON Semiconductor or its subsidiaries in the United States and/or other countries. ON Semiconductor owns the rights to a number of patents, trademarks, copyrights, trade secrets, and other intellectual property. A listing of ON Semiconductor's product/patent coverage may be accessed at www.onsemi.com/site/pdf/Patent-Marking.pdf. ON Semiconductor reserves the right to make changes without further notice to any products herein. ON Semiconductor makes no warranty, representation or guarantee regarding the suitability of its products for any particular purpose, nor does ON Semiconductor assume any liability arising out of the application or use of any product or circuit, and specifically disclaims any and all liability, including without limitation special, consequential or incidental damages. Buyer is responsible for its products and applications using ON Semiconductor products, including compliance with all laws, regulations and safety requirements or standards, regardless of any support or applications information provided by ON Semiconductor. "Typical" parameters which may be provided in ON Semiconductor data sheets and/or specifications can and do vary in different applications and actual performance may vary over time. All operating parameters, including "Typicals" must be validated for each customer application by customer's technical experts. ON Semiconductor does not convey any license under its patent rights nor the rights of others. ON Semiconductor products are not designed, intended, or authorized for use as a critical component in life support systems or any FDA Class 3 medical devices or medical devices with a same or similar classification in a foreign jurisdiction or any devices intended for implantation in the human body. Should Buyer purchase or use ON Semiconductor products for any such unintended or unauthorized application, Buyer shall indemnify and hold ON Semiconductor and its officers, employees, subsidiaries, affiliates, and distributors harmless against all claims, costs, damages, and expenses, and reasonable attorney fees arising out of, directly or indirectly, any claim of personal injury or death associated with such unintended or unauthorized use, even if such claim alleges that ON Semiconductor was negligent regarding the design or manufacture of the part. ON Semiconductor is an Equal Opportunity/Affirmative Action Employer. This literature is subject to all applicable copyright laws and is not for resale in any manner.

74VCX86

Low Voltage Quad 2-Input Exclusive-OR Gate with 3.6V Tolerant Inputs and Outputs

General Description

The VCX86 contains four 2-input exclusive OR gates. This product is designed for low voltage (1.2V to 3.6V) V_{CC} applications with I/O compatibility up to 3.6V

The 74VCX86 is fabricated with an advanced CMOS technology to achieve high-speed operation while maintaining low CMOS power dissipation.

Features

- 1.2V to 3.6V V_{CC} supply operation
- 3.6V tolerant inputs and outputs
- t_{PD}
3.0 ns max for 3.0V to 3.6V V_{CC}
- Power-off high impedance inputs and outputs
- Static Drive (I_{OH}/I_{OL})
 ± 24 mA @ 3.0V V_{CC}
- Uses proprietary noise/EMI reduction circuit
- Latchup performance exceeds JEDEC 78 conditions
- ESD performance:
Human body model > 2000V
Machine model > 250V
- Leadless Pb-Free DQFN package

Ordering Code:

| Order Number | Package Number | Package Description |
|------------------------|----------------|---|
| 74VCX86M | M14A | 14-Lead Small Outline Integrated Circuit (SOIC), JEDEC MS-012, 0.150" Narrow |
| 74VCX86BQX (Note 1) | MLP014A | Pb-Free 14-Terminal Depopulated Quad Very-Thin Flat Pack No Leads (DQFN), JEDEC MO-241, 2.5 x 3.0mm |
| 74VCX86MTC | MTC14 | 14-Lead Thin Shrink Small Outline Package (TSSOP), JEDEC MO-153, 4.4mm Wide |

Devices also available in Tape and Reel. Specify by appending the suffix letter "X" to the ordering code.
Pb-Free package per JEDEC J-STD-020B.

Note 1: DQFN package available in Tape and Reel only.

74VCX86 Low Voltage Quad 2-Input Exclusive-OR Gate with 3.6V Tolerant Inputs and Outputs

Logic Symbol

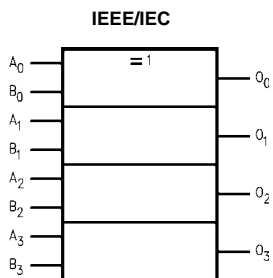

Connection Diagrams

Pin Assignments for SOIC and TSSOP

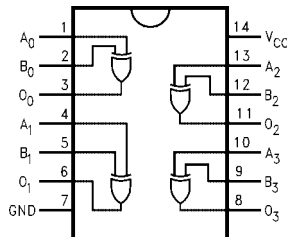

Pin Descriptions

| Pin Names | Description |
|---------------------------------|-------------|
| A _n , B _n | Inputs |
| O _n | Outputs |
| DAP | No Connect |

Note: DAP (Die Attach Pad)

Pad Assignments for DQFN

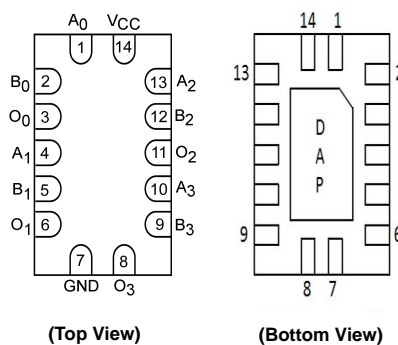

Absolute Maximum Ratings (Note 2)

| | |
|---|-------------------------|
| Supply Voltage (V_{CC}) | -0.5V to +4.6V |
| DC Input Voltage (V_I) | -0.5V to +4.6V |
| Output Voltage (V_O) | |
| HIGH or LOW State (Note 3) | -0.5V to V_{CC} +0.5V |
| $V_{CC} = 0V$ | -0.5V to +4.6V |
| DC Input Diode Current (I_{IK}) $V_I < 0V$ | -50 mA |
| DC Output Diode Current (I_{OK}) | |
| $V_O < 0V$ | -50 mA |
| $V_O > V_{CC}$ | +50 mA |
| DC Output Source/Sink Current (I_{OH}/I_{OL}) | ± 50 mA |
| DC V_{CC} or GND Current per Supply Pin (I_{CC} or Ground) | ± 100 mA |
| Storage Temperature Range (T_{STG}) | -65°C to +150°C |

Recommended Operating Conditions (Note 4)

| | |
|---|-------------------|
| Power Supply | |
| Operating | 1.2V to 3.6V |
| Input Voltage | -0.3V to +3.6V |
| Output Voltage (V_O) | |
| HIGH or LOW State | 0V to V_{CC} |
| Output Current in I_{OH}/I_{OL} | |
| $V_{CC} = 3.0V$ to 3.6V | ± 24 mA |
| $V_{CC} = 2.3V$ to 2.7V | ± 18 mA |
| $V_{CC} = 1.65V$ to 2.3V | ± 6 mA |
| $V_{CC} = 1.4V$ to 1.6V | ± 2 mA |
| $V_{CC} = 1.2V$ | ± 100 μA |
| Free Air Operating Temperature (T_A) | -40°C to +85°C |
| Minimum Input Edge Rate ($\Delta t/\Delta V$) | |
| $V_{IN} = 0.8V$ to 2.0V, $V_{CC} = 3.0V$ | 10 ns/V |

Note 2: The Absolute Maximum Ratings are those values beyond which the safety of the device cannot be guaranteed. The device should not be operated at these limits. The parametric values defined in the Electrical Characteristics tables are not guaranteed at the Absolute Maximum Ratings. The "Recommended Operating Conditions" table will define the conditions for actual device operation.

Note 3: I_O Absolute Maximum Rating must be observed.

Note 4: Floating or unused inputs must be held HIGH or LOW.

DC Electrical Characteristics

| Symbol | Parameter | Conditions | V_{CC} (V) | Min | Max | Units |
|----------|---------------------------|---------------------------|-----------------|----------------------|----------------------|-------|
| V_{IH} | HIGH Level Input Voltage | | 2.7 - 3.6 | 2.0 | | V |
| | | | 2.3 - 2.7 | 1.6 | | |
| | | | 1.65 - 2.3 | $0.65 \times V_{CC}$ | | |
| | | | 1.4 - 1.6 | $0.65 \times V_{CC}$ | | |
| | | | 1.2 | $0.65 \times V_{CC}$ | | |
| V_{IL} | LOW Level Input Voltage | | 2.7 - 3.6 | | 0.8 | V |
| | | | 2.3 - 2.7 | | 0.7 | |
| | | | 1.65 - 2.3 | | $0.35 \times V_{CC}$ | |
| | | | 1.4 - 1.6 | | $0.35 \times V_{CC}$ | |
| | | | 1.2 | | | |
| V_{OH} | HIGH Level Output Voltage | $I_{OH} = -100 \mu A$ | 2.7 - 3.6 | $V_{CC} - 0.2$ | | V |
| | | $I_{OH} = -12 \text{ mA}$ | 2.7 | 2.2 | | |
| | | $I_{OH} = -18 \text{ mA}$ | 3.0 | 2.4 | | |
| | | $I_{OH} = -24 \text{ mA}$ | 3.0 | 2.2 | | |
| | | $I_{OH} = -100 \mu A$ | 2.3 - 2.7 | $V_{CC} - 0.2$ | | |
| | | $I_{OH} = -6 \text{ mA}$ | 2.3 | 2.0 | | |
| | | $I_{OH} = -12 \text{ mA}$ | 2.3 | 1.8 | | |
| | | $I_{OH} = -18 \text{ mA}$ | 2.3 | 1.7 | | |
| | | $I_{OH} = -100 \mu A$ | 1.65 - 2.3 | $V_{CC} - 0.2$ | | |
| | | $I_{OH} = -6 \text{ mA}$ | 1.65 | 1.25 | | |
| | | $I_{OH} = -100 \mu A$ | 1.4 - 1.6 | $V_{CC} - 0.2$ | | |
| | | $I_{OH} = -2 \text{ mA}$ | 1.4 | 1.05 | | |
| | | $I_{OH} = -100 \mu A$ | 1.2 | $V_{CC} - 0.2$ | | |

| DC Electrical Characteristics (Continued) | | | | | | | |
|---|---------------------------------------|--|------------------------|---------------------------------|-----------|-------|------------------|
| Symbol | Parameter | Conditions | V _{CC} (V) | Min | Max | Units | |
| V _{OL} | LOW Level Output Voltage | I _{OL} = 100 μA | 2.7 - 3.6 | | 0.2 | V | |
| | | I _{OL} = 12 mA | 2.7 | | 0.4 | | |
| | | I _{OL} = 18 mA | 3.0 | | 0.4 | | |
| | | I _{OL} = 24 mA | 3.0 | | 0.55 | | |
| | | I _{OL} = 100 μA | 2.3 - 2.7 | | 0.2 | | |
| | | I _{OL} = 12 mA | 2.3 | | 0.4 | | |
| | | I _{OL} = 18 mA | 2.3 | | 0.6 | | |
| | | I _{OL} = 100 μA | 1.65 - 2.3 | | 0.2 | | |
| | | I _{OL} = 6 mA | 1.65 | | 0.3 | | |
| | | I _{OL} = 100 μA | 1.4 - 1.6 | | 0.2 | | |
| I _{OL} = 2 mA | 1.4 | | 0.35 | | | | |
| I _{OL} = 100 μA | 1.2 | | 0.05 | | | | |
| I _I | Input Leakage Current | 0 ≤ V _I ≤ 3.6V | 1.2 - 3.6 | | ±5.0 | μA | |
| I _{OFF} | Power-OFF Leakage Current | 0 ≤ (V _I , V _O) ≤ 3.6V | 0 | | 10 | μA | |
| I _{CC} | Quiescent Supply Current | V _I = V _{CC} or GND V _{CC} ≤ (V _I) | 1.2 - 3.6 1.2 - 3.6 | | 20 ±20 | μA | |
| ΔI _{CC} | Increase in I _{CC} per Input | V _{IH} = V _{CC} - 0.6V | 2.7 - 3.6 | | 750 | μA | |
| AC Electrical Characteristics (Note 5) | | | | | | | |
| Symbol | Parameter | Conditions | V _{CC} (V) | T _A = -40°C to +85°C | | Units | Figure Number |
| | | | | Min | Max | | |
| t _{PHL} t _{PLH} | Propagation Delay | C _L = 30 pF, R _L = 500Ω | 3.3 ± 0.3 | 0.6 | 3.0 | ns | Figures 1, 2 |
| | | | 2.5 ± 0.2 | 0.8 | 3.9 | | |
| | | | 1.8 ± 0.15 | 1.0 | 7.8 | | |
| | | C _L = 15 pF, R _L = 2kΩ | 1.5 ± 0.1 | 1.0 | 15.6 | | Figures 3, 4 |
| 1.2 | 1.5 | 39 | | | | | |
| t _{OSSL} t _{OSLH} | Output to Output Skew (Note 6) | C _L = 30 pF, R _L = 500Ω | 3.3 ± 0.3 | | 0.5 | ns | |
| | | | 2.5 ± 0.2 | | 0.5 | | |
| | | | 1.8 ± 0.15 | | 0.75 | | |
| | | C _L = 15 pF, R _L = 2kΩ | 1.5 ± 0.1 | | 1.5 | | |
| 1.2 | | 1.5 | | | | | |
| <p>Note 5: For C_L = 50 pF, add approximately 300 ps to the AC maximum specification.</p> <p>Note 6: Skew is defined as the absolute value of the difference between the actual propagation delay for any two separate outputs of the same device. The specification applies to any outputs switching in the same direction, either HIGH-to-LOW (t_{OSSL}) or LOW-to-HIGH (t_{OSLH}).</p> | | | | | | | |

Dynamic Switching Characteristics

| Symbol | Parameter | Conditions | V _{CC} (V) | T _A = +25°C | Units |
|------------------|---|--|------------------------|------------------------|-------|
| | | | | Typical | |
| V _{OLP} | Quiet Output Dynamic Peak V _{OL} | C _L = 30 pF, V _{IH} = V _{CC} , V _{IL} = 0V | 1.8 | 0.25 | V |
| | | | 2.5 | 0.6 | |
| | | | 3.3 | 0.8 | |
| V _{OLV} | Quiet Output Dynamic Valley V _{OL} | C _L = 30 pF, V _{IH} = V _{CC} , V _{IL} = 0V | 1.8 | -0.25 | V |
| | | | 2.5 | -0.6 | |
| | | | 3.3 | -0.8 | |
| V _{OHV} | Quiet Output Dynamic Valley V _{OH} | C _L = 30 pF, V _{IH} = V _{CC} , V _{IL} = 0V | 1.8 | 1.5 | V |
| | | | 2.5 | 1.9 | |
| | | | 3.3 | 2.2 | |

Capacitance

| Symbol | Parameter | Conditions | T _A = +25°C | Units |
|------------------|-------------------------------|---|------------------------|-------|
| | | | Typical | |
| C _{IN} | Input Capacitance | V _{CC} = 1.8, 2.5V or 3.3V, V _I = 0V or V _{CC} | 6 | pF |
| C _{OUT} | Output Capacitance | V _I = 0V or V _{CC} , V _{CC} = 1.8V, 2.5V or 3.3V | 7 | pF |
| C _{PD} | Power Dissipation Capacitance | V _I = 0V or V _{CC} , f = 10 MHz, V _{CC} = 1.8V, 2.5V or 3.3V | 20 | pF |

AC Loading and Waveforms (V_{CC} 3.3V ± 0.3V to 1.8V ± 0.15V)

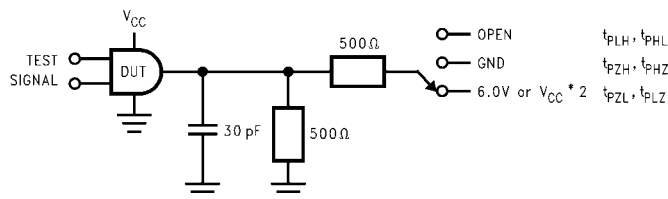

| TEST | SWITCH |
|-------------------------------------|--------|
| t _{PLH} , t _{PHL} | Open |

FIGURE 1. AC Test Circuit

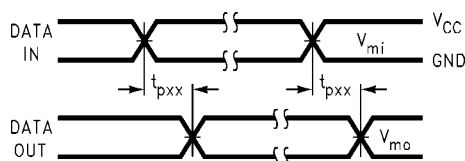
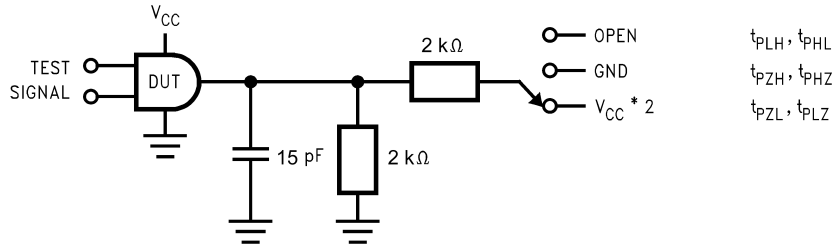

FIGURE 2. Waveform for Inverting and Non-Inverting Functions

| Symbol | V _{CC} | | |
|-----------------|-----------------|--------------------|--------------------|
| | 3.3V ± 0.3V | 2.5V ± 0.2V | 1.8V ± 0.15V |
| V _{mi} | 1.5V | V _{CC} /2 | V _{CC} /2 |
| V _{mo} | 1.5V | V _{CC} /2 | V _{CC} /2 |

AC Loading and Waveforms ($V_{CC} 1.5V \pm 0.1V$ to $1.2V$)



| TEST | SWITCH |
|--------------------|--|
| t_{PLH}, t_{PHL} | Open |
| t_{PZL}, t_{PLZ} | $V_{CC} \times 2$ at $V_{CC} = 1.5 \pm 0.1V$ |
| t_{PZH}, t_{PHZ} | GND |

FIGURE 3. AC Test Circuit

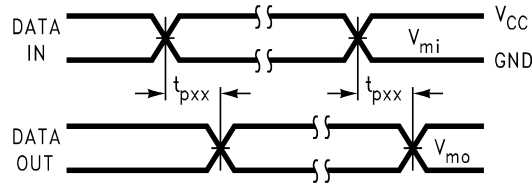

FIGURE 4. Waveform for Inverting and Non-Inverting Functions

| Symbol | V_{CC} |
|----------|-----------------|
| | $1.5V \pm 0.1V$ |
| V_{mi} | $V_{CC}/2$ |
| V_{mo} | $V_{CC}/2$ |

Tape and Reel Specification

Tape Format for DQFN

| Package Designator | Tape Section | Number Cavities | Cavity Status | Cover Tape Status |
|--------------------|--------------------|-----------------|---------------|-------------------|
| BQX | Leader (Start End) | 125 (typ) | Empty | Sealed |
| | Carrier | 2500/3000 | Filled | Sealed |
| | Trailer (Hub End) | 75 (typ) | Empty | Sealed |

TAPE DIMENSIONS inches (millimeters)

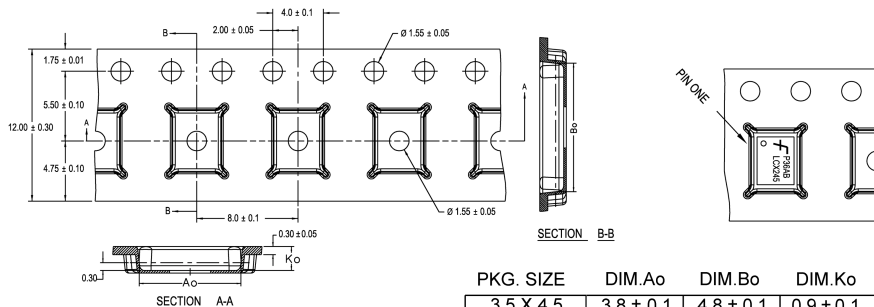

| PKG. SIZE | DIM.Ao | DIM.Bo | DIM.Ko |
|-----------|-----------|-----------|-----------|
| 3.5 X 4.5 | 3.8 ± 0.1 | 4.8 ± 0.1 | 0.9 ± 0.1 |
| 3.0 X 3.0 | 3.3 ± 0.1 | 3.3 ± 0.1 | 0.9 ± 0.1 |
| 2.5 X 4.5 | 2.8 ± 0.1 | 4.8 ± 0.1 | 0.9 ± 0.1 |
| 2.5 X 3.5 | 2.8 ± 0.1 | 3.8 ± 0.1 | 0.9 ± 0.1 |
| 2.5 X 3.0 | 2.8 ± 0.1 | 3.3 ± 0.1 | 0.9 ± 0.1 |
| 2.5 X 2.5 | 2.8 ± 0.1 | 2.8 ± 0.1 | 0.9 ± 0.1 |

DIMENSIONS ARE IN MILLIMETERS

NOTES: unless otherwise specified

1. Cumulative pitch for feeding holes and cavities (chip pockets) not to exceed 0.008[0.20] over 10 pitch span.
2. Smallest allowable bending radius.
3. Thru hole inside cavity is centered within cavity.
4. Tolerance is $\pm 0.002[0.05]$ for these dimensions on all 12mm tapes.
5. Ao and Bo measured on a plane 0.120[0.30] above the bottom of the pocket.
6. Ko measured from a plane on the inside bottom of the pocket to the top surface of the carrier.
7. Pocket position relative to sprocket hole measured as true position of pocket. Not pocket hole.
8. Controlling dimension is millimeter. Dimension in inches rounded.

REEL DIMENSIONS inches (millimeters)

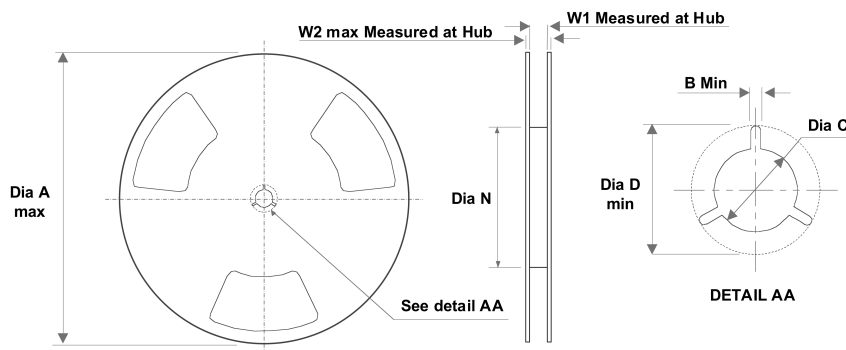

| Tape Size | A | B | C | D | N | W1 | W2 |
|-----------|---------------|-----------------|------------------|------------------|----------------|-----------------|-----------------|
| 12 mm | 13.0 (330) | 0.059 (1.50) | 0.512 (13.00) | 0.795 (20.20) | 7.008 (178) | 0.488 (12.4) | 0.724 (18.4) |

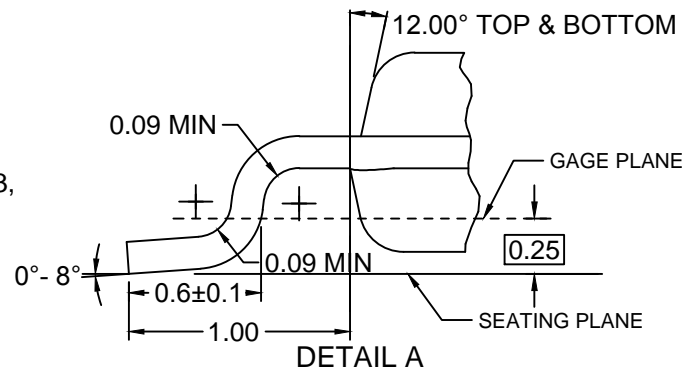
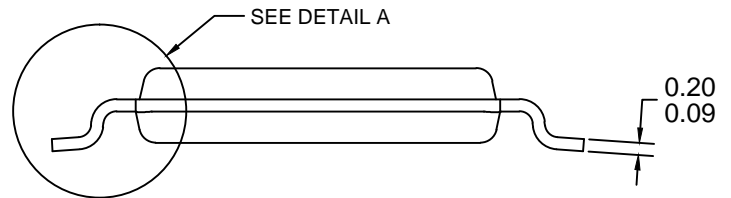
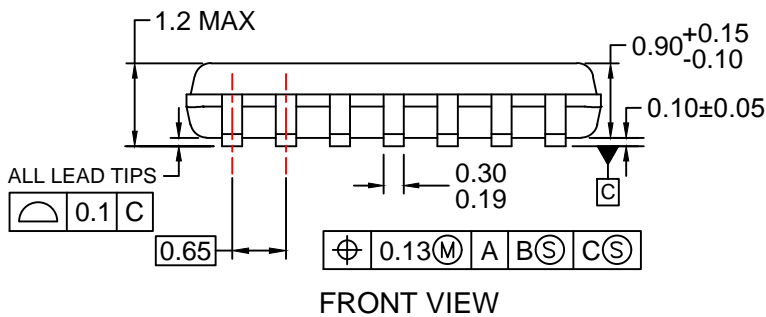
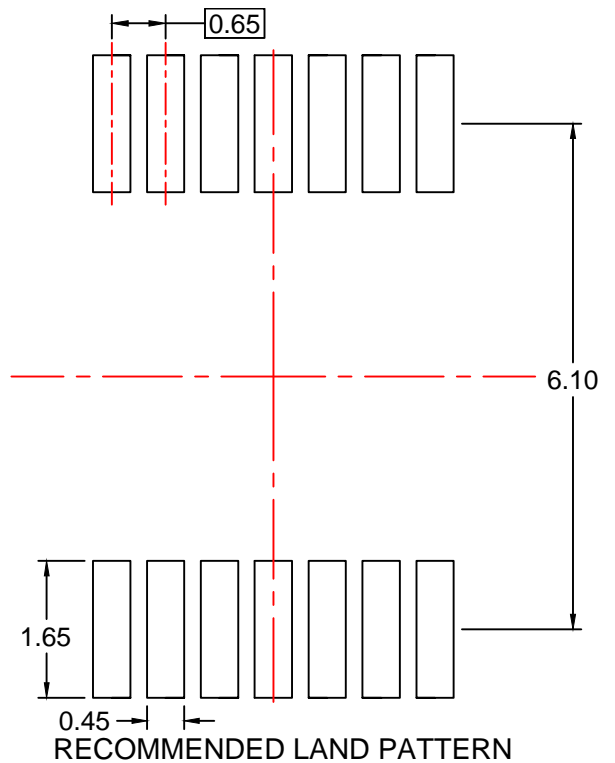
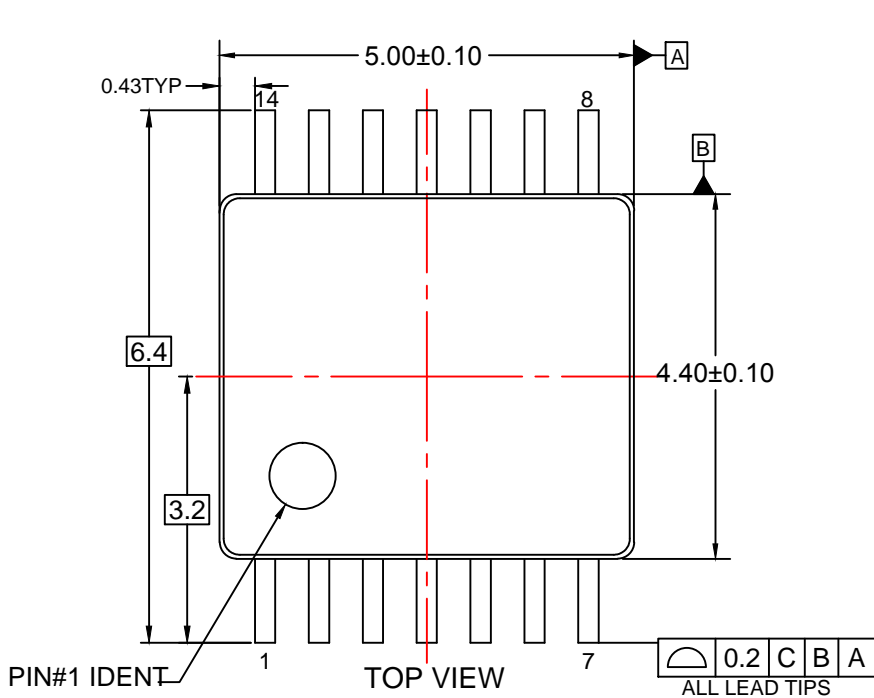

NOTES:

- A. CONFORMS TO JEDEC REGISTRATION MO-153, VARIATION AB, REF NOTE 6
- B. DIMENSIONS ARE IN MILLIMETERS.
- C. DIMENSIONS ARE EXCLUSIVE OF BURRS, MOLD FLASH, AND TIE BAR EXTRUSIONS
- D. DIMENSIONING AND TOLERANCES PER ANSI Y14.5M, 2009.
- E. LANDPATTERN STANDARD: SOP65P640X110-14M.
- F. DRAWING FILE NAME: MKT-MTC14rev7.



ON Semiconductor and  are trademarks of Semiconductor Components Industries, LLC dba ON Semiconductor or its subsidiaries in the United States and/or other countries. ON Semiconductor owns the rights to a number of patents, trademarks, copyrights, trade secrets, and other intellectual property. A listing of ON Semiconductor's product/patent coverage may be accessed at www.onsemi.com/site/pdf/Patent-Marking.pdf. ON Semiconductor reserves the right to make changes without further notice to any products herein. ON Semiconductor makes no warranty, representation or guarantee regarding the suitability of its products for any particular purpose, nor does ON Semiconductor assume any liability arising out of the application or use of any product or circuit, and specifically disclaims any and all liability, including without limitation special, consequential or incidental damages. Buyer is responsible for its products and applications using ON Semiconductor products, including compliance with all laws, regulations and safety requirements or standards, regardless of any support or applications information provided by ON Semiconductor. "Typical" parameters which may be provided in ON Semiconductor data sheets and/or specifications can and do vary in different applications and actual performance may vary over time. All operating parameters, including "Typicals" must be validated for each customer application by customer's technical experts. ON Semiconductor does not convey any license under its patent rights nor the rights of others. ON Semiconductor products are not designed, intended, or authorized for use as a critical component in life support systems or any FDA Class 3 medical devices or medical devices with a same or similar classification in a foreign jurisdiction or any devices intended for implantation in the human body. Should Buyer purchase or use ON Semiconductor products for any such unintended or unauthorized application, Buyer shall indemnify and hold ON Semiconductor and its officers, employees, subsidiaries, affiliates, and distributors harmless against all claims, costs, damages, and expenses, and reasonable attorney fees arising out of, directly or indirectly, any claim of personal injury or death associated with such unintended or unauthorized use, even if such claim alleges that ON Semiconductor was negligent regarding the design or manufacture of the part. ON Semiconductor is an Equal Opportunity/Affirmative Action Employer. This literature is subject to all applicable copyright laws and is not for resale in any manner.

PUBLICATION ORDERING INFORMATION

LITERATURE FULFILLMENT:

Literature Distribution Center for ON Semiconductor
19521 E. 32nd Pkwy, Aurora, Colorado 80011 USA
Phone: 303-675-2175 or 800-344-3860 Toll Free USA/Canada
Fax: 303-675-2176 or 800-344-3867 Toll Free USA/Canada
Email: orderlit@onsemi.com

N. American Technical Support: 800-282-9855 Toll Free
USA/Canada
Europe, Middle East and Africa Technical Support:
Phone: 421 33 790 2910
Japan Customer Focus Center
Phone: 81-3-5817-1050

ON Semiconductor Website: www.onsemi.com
Order Literature: <http://www.onsemi.com/orderlit>
For additional information, please contact your local
Sales Representative

Looking for pricing, stock, or lifecycle information?

Click below to explore more details on WIN SOURCE:

- ⊖ [View 74VCX86MTCX on WIN SOURCE](#)
- ⊖ [Fairchild/ON Semiconductor Information](#)

Optimize Your Supply Chain with WIN SOURCE Solutions

- ✓ Global Sourcing Solution
- ✓ Obsolete Management
- ✓ Cost Control Management
- ✓ Shortage Management
- ✓ Alternative Solution
- ✓ Excess Inventory Management